

{10.45}



Super Erecta® Shelf Dunnage Shelves — DR Series

Super Erecta® Dunnage Shelves offer considerably more weight-bearing capacity than other Super Erecta Shelf shelves.

- **Superior Strength:** Dunnage shelves can be combined with other Super Erecta® Shelf shelves to provide extra strength at the lower levels of a shelving unit where the heaviest loads will be placed.
- **Stress Resistance:** The high static-load capacity of the Super Erecta® Shelf dunnage shelf translates into an increased ability to stand up under the strain of unbalanced loads and the stress of materials repeatedly being placed on the shelf in a less-than-gentle way.
- **Super Erecta® Shelf Construction:** These dunnage shelves have the same tapered corners and split sleeves that fit the 1" (25mm) posts used for other Super Erecta® Shelf shelving. As a result, they assemble easily and fit securely.
- **Easy-to-Clean:** Removable wire deck fits over reinforced 1" (25mm) square, tubular frame. It lifts off for easy, thorough cleaning.
- **Smooth Loading / Unloading:** The front-to-back upper ribs of the deck allow you to slide items on and off the shelves smoothly.
- **Adjustable:** Rolled grooves on the posts enable dunnage shelves to be positioned or repositioned at desired levels in 1" (25mm) increments.
- **Choice of Finishes:** Chrome-plated for dry storage; Metroseal™ Epoxy (green or gray), and Type 304 stainless steel for corrosive environments.
- **Metroseal:** Proprietary rust-resistant finish is a durable epoxy coating over a protective zinc substrate. Metroseal contains Microban® antimicrobial product protection that helps fight the growth of stain and odor-causing bacteria to keep product cleaner between cleanings. 12-year limited warranty against rust and corrosion.
- **Load Capacity:** The 24" (610 mm) to 36" (914 mm) length has a 1,600-pound (725 kg) evenly distributed static load capacity; the 42" (1067 mm) to 48" (1219 mm) shelves hold up to 1,300 pounds (590 kg), the 54" (1372 mm) and 60" (1525 mm) length hold up to 1,000 pounds (450 kg).

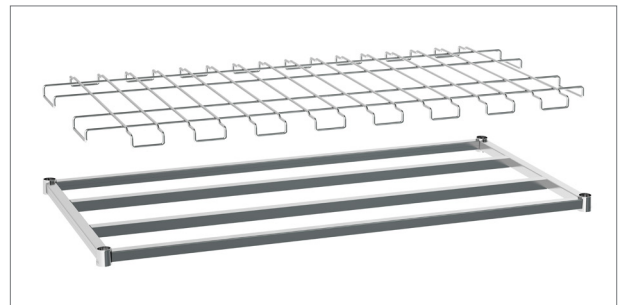

Super Erecta with Metroseal



Gray Metroseal Epoxy
Finish with Microban



Green Metroseal Epoxy
Finish with Microban



MICROBAN® and the MICROBAN® symbol are registered trademarks of the Microban® Products Company, Huntersville, NC. Microban® product protection does not by itself protect a user from food borne illness. Product must be routinely cleaned.



All Metro Catalog Sheets are available on our website: metro.com

LO2-022A | 10/24

Information and specifications are subject to change without notice.
Please confirm at time of order.
Copyright © 2024 InterMetro Industries Corp.

metro.com
North Washington Street, Wilkes-Barre, PA 18705
Product Information: U.S. and Canada: 1.800.992.1776
Outside U.S. and Canada: metro.com/contactus

{10.45}



Super Erecta® Shelf Dunnage Shelves — DR Series

Dimensions

Shelves

- The shelf support frame is made of 1" (25 mm) square tubing.
- The removable wire deck is formed from 5/16" (7.9 mm) diameter wire.

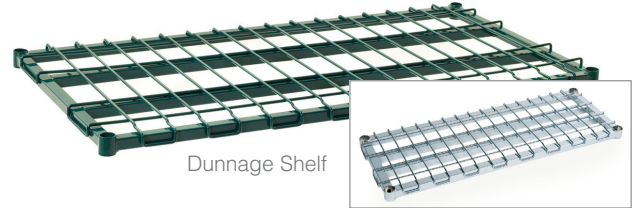

Cat. No. Dunnage Shelf Chrome	Cat. No. Dunnage Shelf Metroseal Green	Cat. No. Dunnage Shelf Metroseal Gray	Cat. No. Dunnage Shelf Stainless	Nominal Width/Length (in.)	(mm)	Actual Width/Length (in.)	(mm)	Approx. Pkd. Wt. (lbs.)	(kg)
1824DRC	1824DRK3	-	-	18x24	457x610	18 ⁵ / ₃₂ x 24 ¹³ / ₃₂	461x620	13	5.9
1830DRC	1830DRK3	-	-	18x30	457x760	18 ⁵ / ₃₂ x 30 ¹³ / ₃₂	461x772	17	7.7
1836DRC	1836DRK3	1836DRK4	1836DRS	18x36	457x914	18 ⁵ / ₃₂ x 36 ¹³ / ₃₂	461x925	19	8.6
-	1842DRK3	-	-	18x42	457x1066	18 ⁵ / ₃₂ x 42 ¹³ / ₃₂	461x1077	22	10
1848DRC	1848DRK3	1848DRK4	1848DRS	18x48	457x1219	18 ⁵ / ₃₂ x 48 ¹³ / ₃₂	461x1230	25	11.3
-	1854DRK3	-	-	18x54	457x1372	18 ⁵ / ₃₂ x 54 ¹³ / ₃₂	461x1382	28	12.6
1860DRC	1860DRK3	1860DRK4	1860DRS	18x60	457x1524	18 ⁵ / ₃₂ x 60 ¹³ / ₃₂	461x1534	30	13.6
-	2124DRK3	-	-	21x24	530x610	21 ⁵ / ₃₂ x 24 ¹³ / ₃₂	537x620	14	6.4
-	2130DRK3	-	-	21x30	530x760	21 ⁵ / ₃₂ x 30 ¹³ / ₃₂	537x772	18	8.2
-	2136DRK3	-	-	21x36	530x914	21 ⁵ / ₃₂ x 36 ¹³ / ₃₂	537x925	20	9.1
-	2142DRK3	-	-	21x42	530x1066	21 ⁵ / ₃₂ x 42 ¹³ / ₃₂	537x1077	23	10.4
-	2148DRK3	-	-	21x48	530x1219	21 ⁵ / ₃₂ x 48 ¹³ / ₃₂	537x1230	26	11.8
-	2154DRK3	-	-	21x54	530x1372	21 ⁵ / ₃₂ x 54 ¹³ / ₃₂	537x1382	29	13.2
-	2160DRK3	-	-	21x60	530x1524	21 ⁵ / ₃₂ x 60 ¹³ / ₃₂	537x1534	32	14.5
2424DRC	2424DRK3	-	-	24x24	610x610	24 ⁵ / ₃₂ x 24 ¹³ / ₃₂	614x620	14	6.4
2430DRC	2430DRK3	2430DRK4	-	24x30	610x760	24 ⁵ / ₃₂ x 30 ¹³ / ₃₂	614x772	18	8.2
2436DRC	2436DRK3	2436DRK4	2436DRS	24x36	610x914	24 ⁵ / ₃₂ x 36 ¹³ / ₃₂	614x925	21	9.5
-	2442DRK3	2442DRK4	-	24x42	610x1066	24 ⁵ / ₃₂ x 42 ¹³ / ₃₂	614x1077	24	10.9
2448DRC	2448DRK3	2448DRK4	2448DRS	24x48	610x1219	24 ⁵ / ₃₂ x 48 ¹³ / ₃₂	614x1230	27	12.3
-	2454DRK3	2454DRK4	-	24x54	610x1372	24 ⁵ / ₃₂ x 54 ¹³ / ₃₂	614x1382	30	13.6
2460DRC	2460DRK3	2460DRK4	2460DRS	24x60	610x1524	24 ⁵ / ₃₂ x 60 ¹³ / ₃₂	614x1534	33	15

Posts

Cat. No. Chrome	Cat. No. Metroseal Green with Microban	Cat. No. Metroseal Gray with Microban	Cat. No. Stainless	Actual Height (in.)	(mm)	Approx. Pkd. Wt. (lbs.)	(kg)
63P	63PK3	63PK4	63PS	62 ⁷ / ₁₆	1585	3 ¹ / ₂	1.6
74P	74PK3	74PK4	74PS	74.5	1892	4	1.8
86P	86PK3	86PK4	86PS	86.5	2197	5	2.3

Important:

- Stability decreases as the ratio of height to width increases when heavier loads are placed on upper shelves. Keep units as wide and low as possible, using the dunnage shelf as the bottom shelf. If two dunnage shelves are being used, both should be placed within the lower half of the unit. Dunnage shelves are not recommended for use in shelf carts or trucks.
- S-Hooking not available for dunnage shelving.