

"4CO4R5" MODULAR BASE WORK TABLES

14GA Stainless Steel Top w/5" Rear Riser - Open Front

FEATURES:

- 5" Backsplash Top With 1-1/2" Stallion Edge On Front And 90 Degree Bend Down Side Edge For Table Line-Up
- Top Is Sound Deadened Reinforced With 2"x3" Channel Running Entire Length Of Top
- Stainless Steel Leg With Adjustable Feet
- Optional Fixed (Suffix "-1S") Or Adjustable (Suffix "-1AS") Intermediate Shelf Available
- 36" Working Height
- Shipped Standard Welded Set-Up

SPECIFICATIONS:

- Top: Stainless Steel Cabinet Tops TIG Welded, Exposed Welds Are Polished To Match Adjacent Surface #4 Polished, Satin Finish
- Removable Stainless Steel Legs
- Top: 14GA Type 300 Stainless Steel With #4 Polish, Satin Finish
- Body: 18GA Type 430 Stainless Steel
- Legs: Stainless Steel With Adjustable Feet



4CO4R5-3048

CERTIFICATIONS:



"4CO4R5" MODULAR BASE WORK TABLES

LENGTH	24" WIDE	WT (LBS)	30" WIDE	WT (LBS)	36" WIDE	WT (LBS)
36"	4CO4R5-2436	210	4CO4R5-3036	235	4CO4R5-3636	260
48"	4CO4R5-2448	250	4CO4R5-3048	270	4CO4R5-3648	300
60"	4CO4R5-2460	290	4CO4R5-3060	310	4CO4R5-3660	340
72"	4CO4R5-2472	335	4CO4R5-3072	350	4CO4R5-3672	385
84"	4CO4R5-2484	375	4CO4R5-3084	390	4CO4R5-3684	425
96"	4CO4R5-2496	425	4CO4R5-3096	435	4CO4R5-3696	470
108"	4CO4R5-24108	465	4CO4R5-30108	475	4CO4R5-36108	510
120"	4CO4R5-24120	500	4CO4R5-30120	525	4CO4R5-36120	550
132"	4CO4R5-24132	535	4CO4R5-30132	568	4CO4R5-36132	593
144"	4CO4R5-24144	570	4CO4R5-30144	610	4CO4R5-36144	635

ALL DIMENSIONS ARE TYPICAL. TOLERANCE +/- .500". JOHN BOOS & CO. RESERVES THE RIGHT TO CHANGE SPECIFICATIONS WITHOUT NOTICE.

DETAILED SPECIFICATIONS

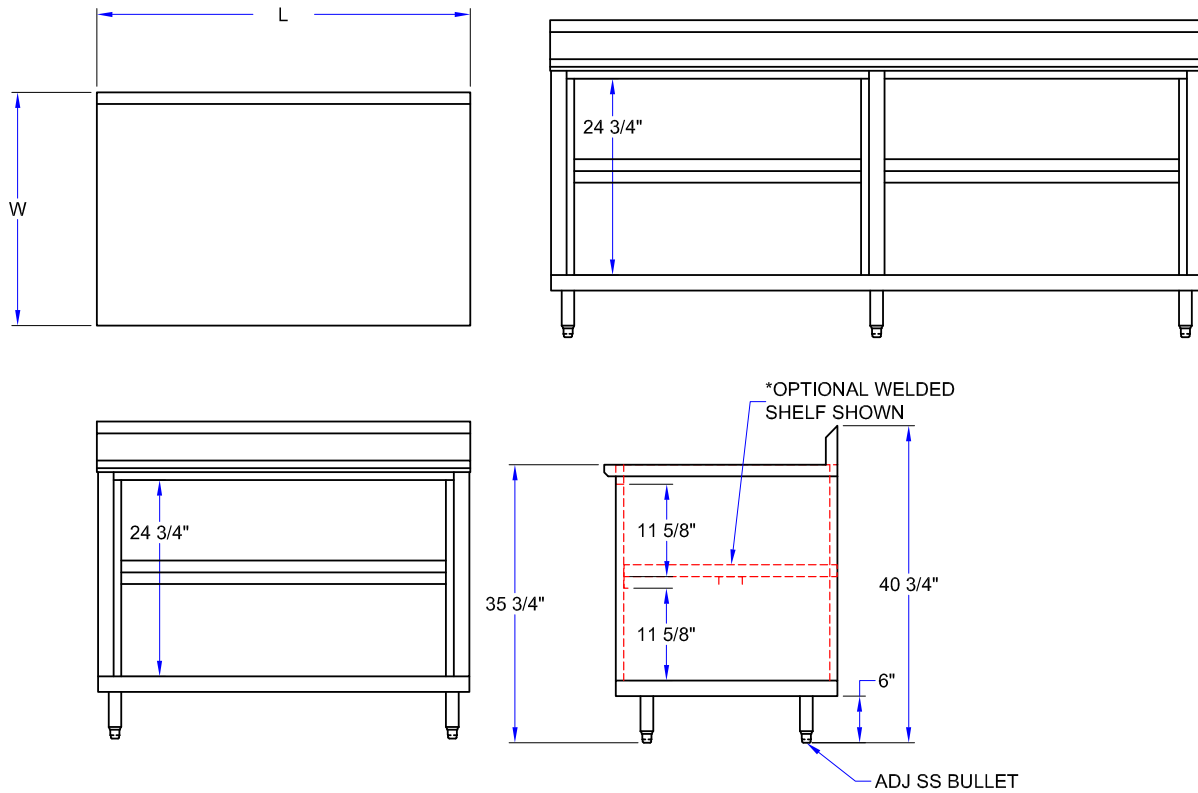

MODEL # STRUCTURE

4 = 14GA Top
 CO = Open Front
 4 = 430 S.S. Body

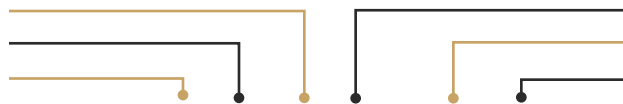

R5 = 5" Tall Riser
 24 = Width
 60 = Length

4CO4R5-2460

"4CO4R5" MODULAR BASE WORK TABLES

LENGTH	24" WIDE	WT (LBS)	30" WIDE	WT (LBS)	36" WIDE	WT (LBS)
36"	4CO4R5-2436	210	4CO4R5-3036	235	4CO4R5-3636	260
48"	4CO4R5-2448	250	4CO4R5-3048	270	4CO4R5-3648	300
60"	4CO4R5-2460	290	4CO4R5-3060	310	4CO4R5-3660	340
72"	4CO4R5-2472	335	4CO4R5-3072	350	4CO4R5-3672	385
84"	4CO4R5-2484	375	4CO4R5-3084	390	4CO4R5-3684	425
96"	4CO4R5-2496	425	4CO4R5-3096	435	4CO4R5-3696	470
108"	4CO4R5-24108	465	4CO4R5-30108	475	4CO4R5-36108	510
120"	4CO4R5-24120	500	4CO4R5-30120	525	4CO4R5-36120	550
132"	4CO4R5-24132	535	4CO4R5-30132	568	4CO4R5-36132	593
144"	4CO4R5-24144	570	4CO4R5-30144	610	4CO4R5-36144	635

ALL DIMENSIONS ARE TYPICAL. TOLERANCE +/- .500". JOHN BOOS & CO. RESERVES THE RIGHT TO CHANGE SPECIFICATIONS WITHOUT NOTICE.