

CR1824TG3B			
ITEM #	QTY	PART #	DESCRIPTION
1	2	42CPBL	42" BLACK POST
2	2	27PBL	27" BLACK POST
3	3	1824NBL	18" X 24" SES SHELF- BLACK
4	1	H124B	HANGER RAIL 24" BLACK
5	6	9990P	LABEL HOLDER, GRAY 3' LONG
6	1	DD9957-24	SIGNBOARD ASSY 24"
7	3	DD9090B	18" X 24" CLEAR SHELF INLAY

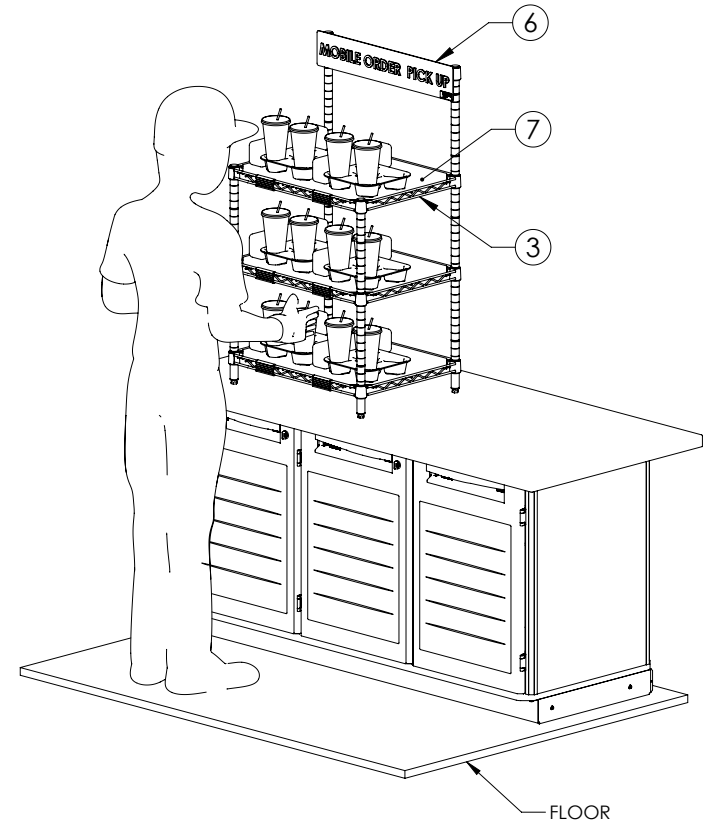
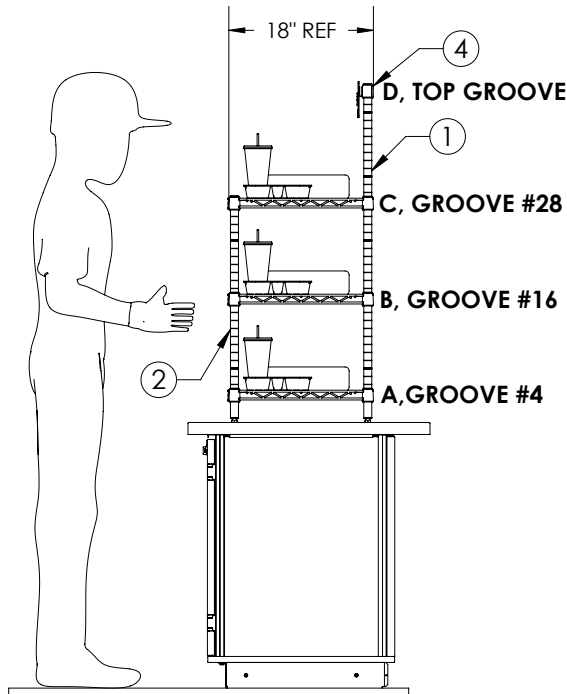
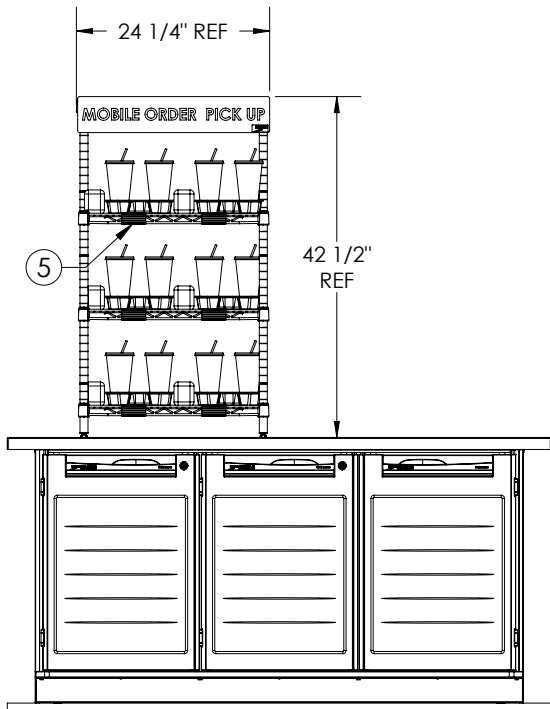
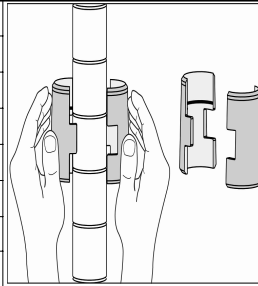

THREE BAY VERSION

DRAWN BY:	SSC
DATE:	05/06/2020
SW CAD FILE:	TO GO PICK UP STATION
PART NO. :	
SHT 1 of 1	

THE DRAWING AND THE SUBJECT MATTER DEPICTED HEREIN ARE THE SOLE AND EXCLUSIVE PROPERTY OF INTERMETRO INDUSTRIES CORPORATION. ALL RIGHTS WITH RESPECT TO THIS DRAWING AND THE SUBJECT MATTER DEPICTED HEREIN ARE EXPRESSLY RESERVED AND WITHHELD BY INTERMETRO INDUSTRIES CORPORATION.



InterMetro Industries Corp.
North Washington Street
Wilkes-Barre, PA 18705
www.metro.com

CR1824TG3B
18 X 24 X 42 UNIT