

Customer/Wholesaler:	Date:	Job Name:	Model Specified:	Quantity:
Contractor:	Architect/Engineer:			

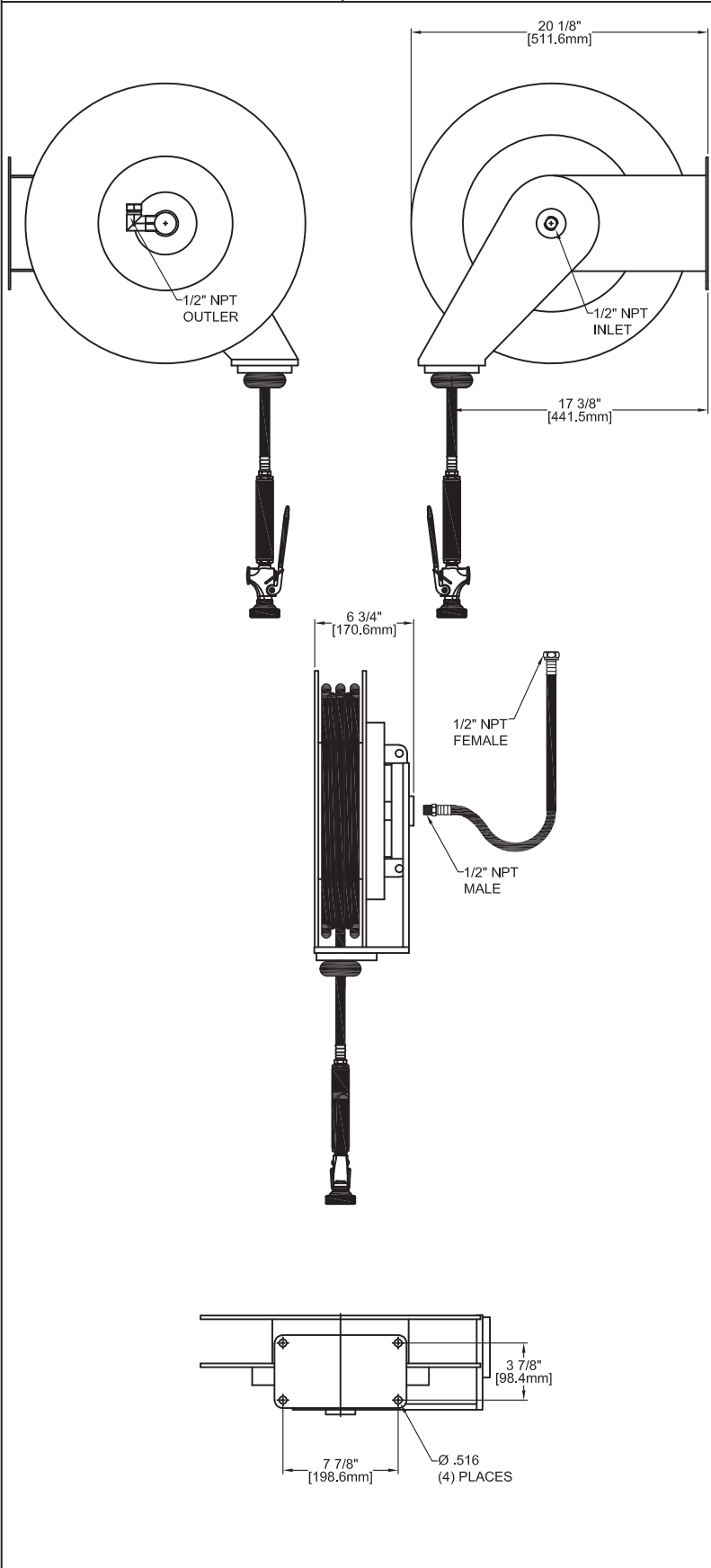

MODEL:
 75395 REEL EXP 50 SV WITH PRO SPRAY VALVE

OPTIONS OR MODIFICATIONS:
 OTHER _____

FEATURES

REEL

- * SELF-LOCKING
- * EXPOSED HOSE
- * 50' LENGTH REEL HOSE
- * 24" LENGTH INLET HOSE
- * 3 PLY FIBER REINFORCED RUBBER HOSE
- * ADJUSTABLE BALL STOP

PRO SPRAY VALVE

- * NOZZLE THREADED INTO VALVE
- * 2.65 GPM AT 80 PSI
- * SHOWER SPRAY PATTERN

SYSTEM LIMITS

- * TEMP: 40°F MIN. TO 160°F MAX.
- * PRESSURE: 200 PSI MAX. STATIC

SHIPPING WEIGHT

- * 52.0 LBS