

American Dish Service
 Manufacturers of Ware Washing Equipment
 WWW.AMERICANDISH.COM

U.S. REGISTERED PATENTS
Model ADC-66 Specifications

**LEFT FEED
 (W/ VENT OPTION)**

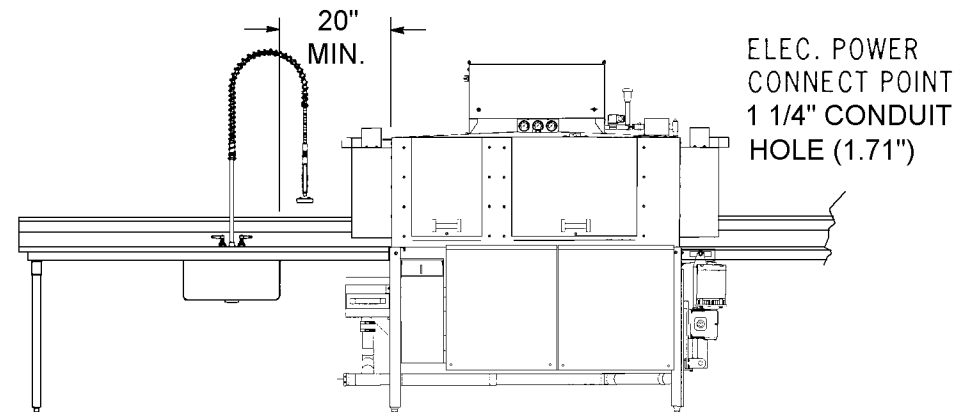

TOP VIEW OF LEFT FEED

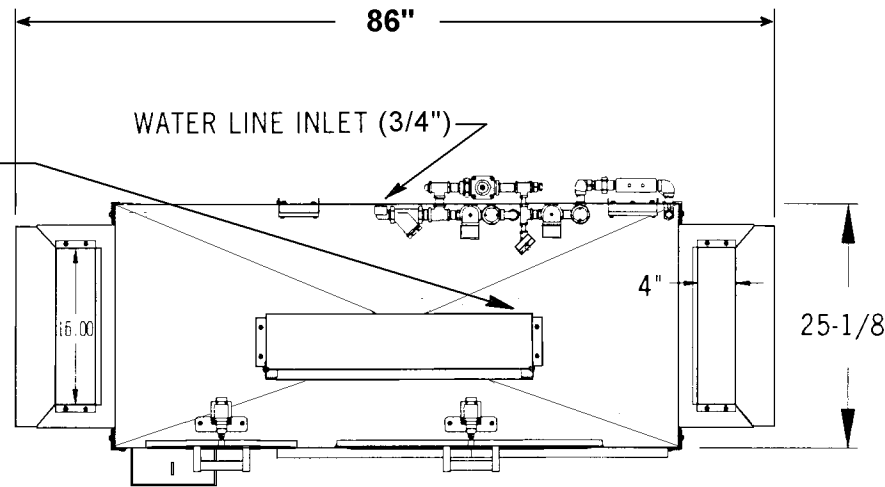

IMPORTANT NOTES

Both clean and soiled tables are to be bolted to the dishmachine with the 1/4-20x1/2" bolts and nuts provided.

Leaks cause potential problems in electrical and mechanical areas under the machine.

Quick drains (table scuppers) are not compatible with stage type conveyor dishmachines.

Scrap sinks shall be no closer than 20" minimum from the dishmachine end of table.

The clean exit table should be at least 72" straight for efficient conveyor operation.

Electrical and plumbing connects must be made by a qualified service person who will comply with all appropriate state and local health, electrical, plumbing, and safety codes.

* Manufacturer reserves the right to modify these specifications in compliance with regulatory agencies and manufacturing expediency.

NOTE:

All dimensions listed have a tolerance of + or - 1/8" unless otherwise noted.

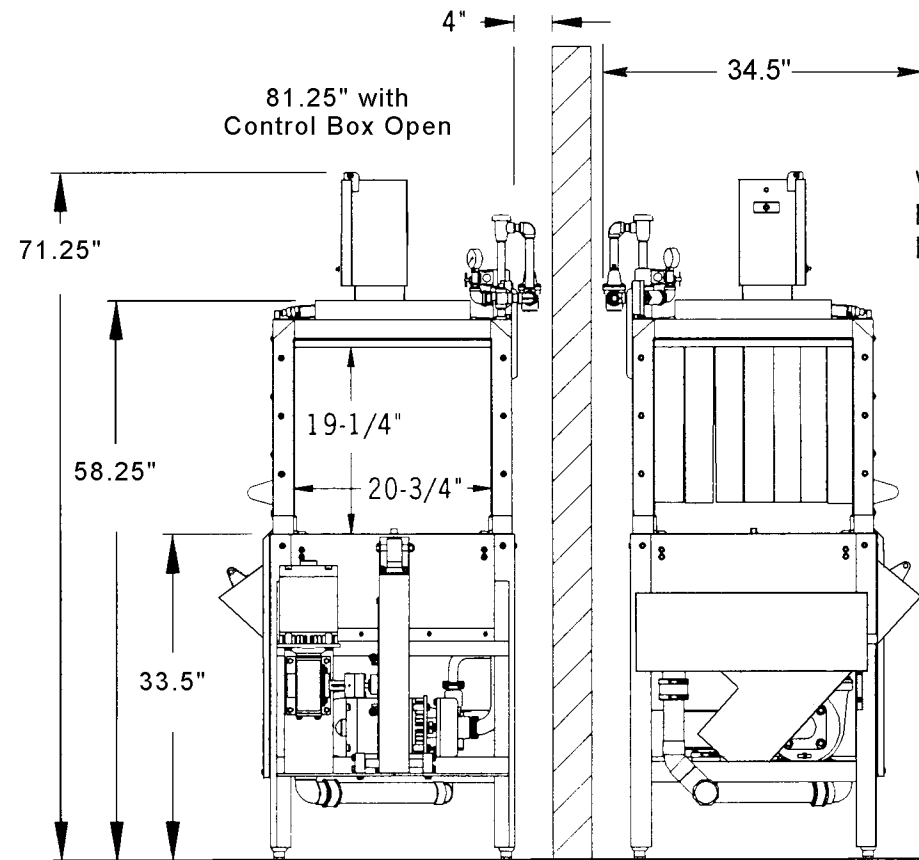
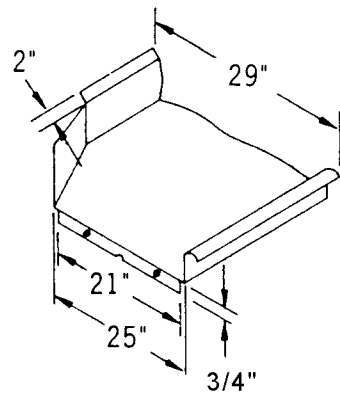

CLEANSIDE VIEW

SOILSIDE VIEW

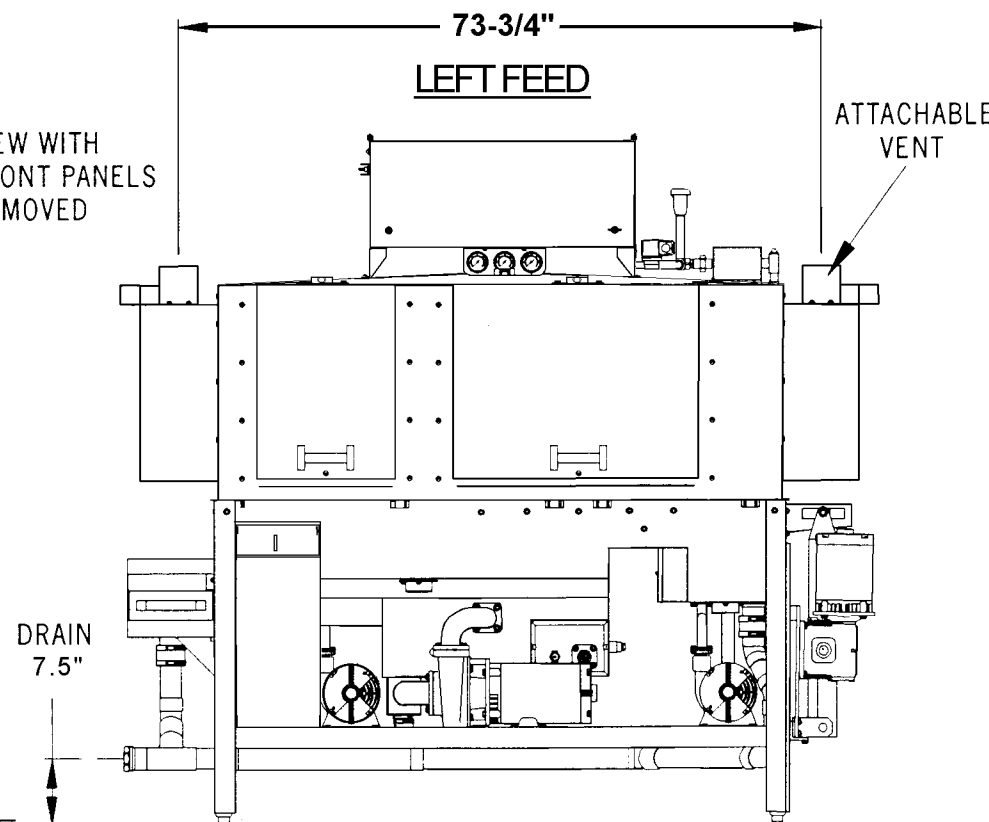

FRONT VIEW

ADC-66

FAMILY MODELS (left or right feed)

	ADC-66 HOT TEMP	ADC-66 CHEMICAL
NSF RATED CAPACITY	244 rack/hr	244 rack/hr
CONVEYOR SPEED	6.8 ft/min or 2.07 meters	6.8 ft/min or 2.07 meters
WATER CONSUMPTION	.49 gal/rack or 1.8 liter	.49 gal/rack or 1.8 liter
TOTAL GAL. PER HR.	120 gph or 454.2 liters	120 gph or 454.2 liters
FINAL RINSE TEMP (20 psi)	180° F/ 82.2 C	120° F/ 48.8 C
SANITIZER	180° WATER	50ppm CHLORINE
ELECTRICAL POWER SUPPLY	... 208/240v, 3 ph, 90 a, 60 Hz <i>3 Phase installation requires 3 gauge wires with a 10 gauge neutral wire, a suitable ground, and a clean circuit.</i>	
MOTOR RATINGS	1.5 HP SCRAP, 3 HP WASH 1/3 HP RINSE, 1/3 HP CONVEYOR	
HEATER RATINGS	18KW WASH, 2.25KW RINSE	
RACK SIZE	STANDARD 19.75" x 19.75" 50.2 x 50.2 cm	
ACCESS DOOR CLEARANCE	15" x 24.5" 38.1 x 62.2 cm	
RACK CLEARANCE (Through machine)	19.25" x 20.75" 48.9 x 52.7 cm	
WATER INLET	(3/4") F.P.T.	
DRAIN SIZE	(2") F.P.T.	
HEIGHT (with door open)	73.75" (81.25" or 206.3 cm with control box cover open)	
WIDTH (Overall)	86" 218.4 cm	
WIDTH, TABLE TO TABLE	66" 167.6 cm	
DEPTH	34.5" 87.6 cm	
SHIPPING WEIGHT	960 POUNDS 435.4 kg	
SHIPPING VOLUME (CRATED)	153.4 CU. FT. 4.3 cu meters	