

BUILT-IN (BOTTOM MOUNT) INSULATED "SQUARE CORNER" FOOD WARMERS

BM-80CDS

ELECTRICAL

| MODEL | VOLTS | WATTS | AMPS | PHASE | FIELD WIRING GAUGE | TEMP. RATING |
|----------|-------|-------|------|--------|--------------------|--------------|
| BM-80CDS | 120 | 1200 | 10 | SINGLE | #14 AWG Cu | 90°C MIN. |
| BM-80CDS | 208 | 1240 | 6 | SINGLE | #14 AWG Cu | 90°C MIN. |
| BM-80CDS | 240 | 1650 | 6.9 | SINGLE | #14 AWG Cu | 90°C MIN. |

CUTOUT DETAILS

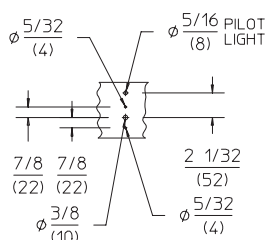
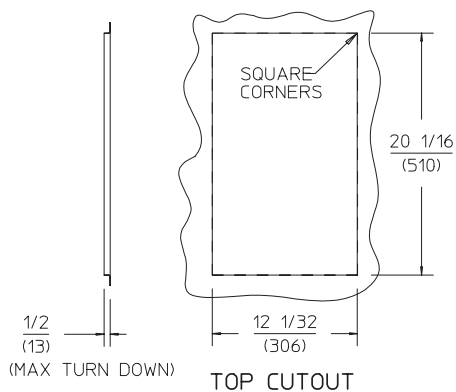

FRONT PANEL CUTOUT

PRODUCT DIMENSIONS

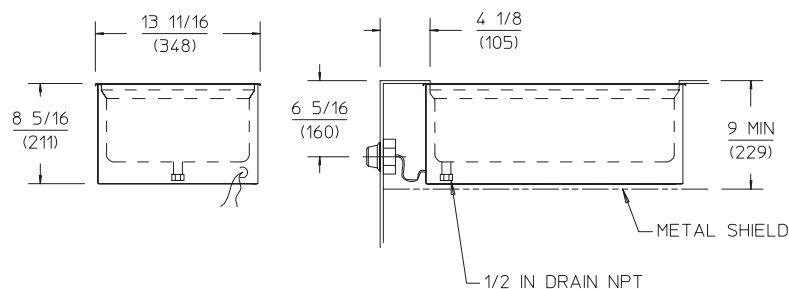
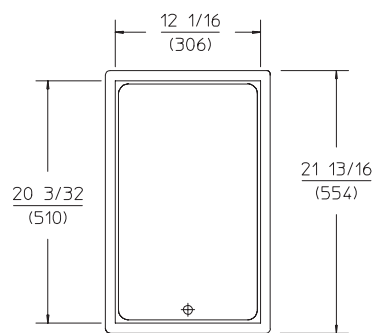

CLEARANCES

| SUGGESTED CLEARANCES FROM UNIT TO THE NEAREST SURFACE | | | |
|---|--------|-------------|-------------|
| BACK | SIDE | BOTTOM | FRONT |
| 1 (25) | 1 (25) | 6 3/4 (171) | 4 1/8 (105) |

SEE CONDITIONS OF ACCEPTABILITY BELOW.

INSTALLATION INSTRUCTIONS

UNIT MUST BE INSTALLED IN AN ALL METAL COUNTER.

THE INSTALLATION OF RECOGNIZED COMPONENT UNITS REQUIRES ADDITIONAL EVALUATIONS TO UNDERWRITERS LABORATORIES INC. STANDARDS.

INSTALLER MUST MEET CONDITIONS OF ACCEPTABILITY OUTLINED BELOW UPON INSTALLATION:

1. This appliance shall be installed in an all metal counter with suitable wiring and control enclosures conforming to national and local electrical codes.
2. Electrical component temperatures, including wiring, within and surrounding the appliance must be monitored in the end use installation for suitability.
3. Electrical grounding of all dead metal parts must be reliably connected to the grounding means of the appliance and must comply with requirements outlined in the appropriate Underwriters Laboratories Inc. classification, national, and local electrical codes.
4. Increased clearances are required if storage of combustible materials is in close proximity to this appliance.
5. Unit shall be accessible for servicing from the bottom.
6. The name/rating plate information shall be accessible.
7. For water and waste connections: This appliance is to be installed to comply with the applicable federal, state or local plumbing codes.

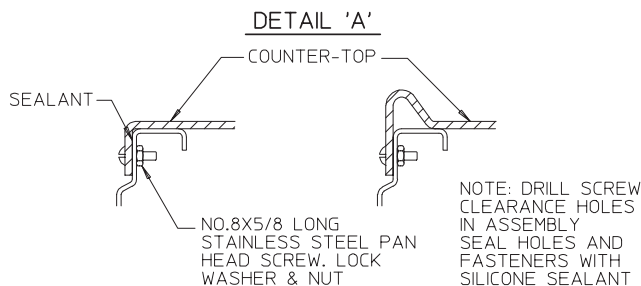

TO FABRICATE AND INSTALL:

1. Lay out cutout dimensions on countertop and apron.
2. Cut and/or drill holes as required in countertop and apron.
3. Turn down flange with square corners (maximum 1/2 inch).
4. To install, position warmer underneath so that turn down is positioned onto embossed shoulders of warmer. Drill as required.
5. Remove warmer and apply a bead of silicone sealant to shoulder area. Remount and secure warmer to fixture with stainless steel screws (see Detail 'A' above).
6. Mount control to apron.
7. Connect supply connection wiring to thermostat. Check nameplate for correct voltage.

NOTE: The BM-80CDS warmer is supplied with a drain hole at one end and a 1/2 inch female N.P.T. drain nipple.