

BUILT-IN RECTANGULAR FOOD AND LIQUID WARMERS

HFW-12S

ELECTRICAL

MODEL	VOLTS	WATTS	AMPS	PHASE	FIELD WIRING GAUGE	TEMP. RATING
HFW-12S	120	825	6.9	SINGLE	#14 AWG Cu	90°C MIN.
HFW-12DS	120	825	3.75	SINGLE	#14 AWG Cu	90°C MIN.

CUTOUT DETAILS

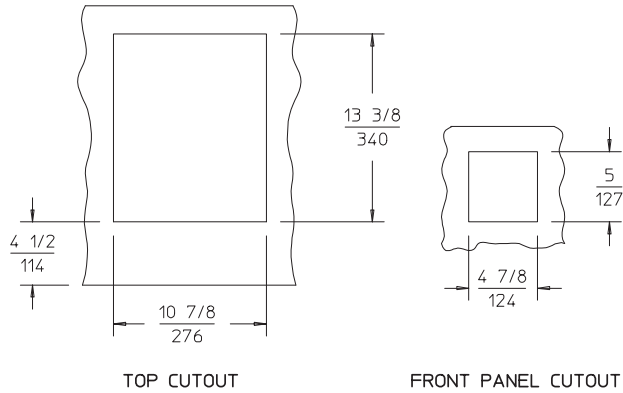

PRODUCT DIMENSIONS

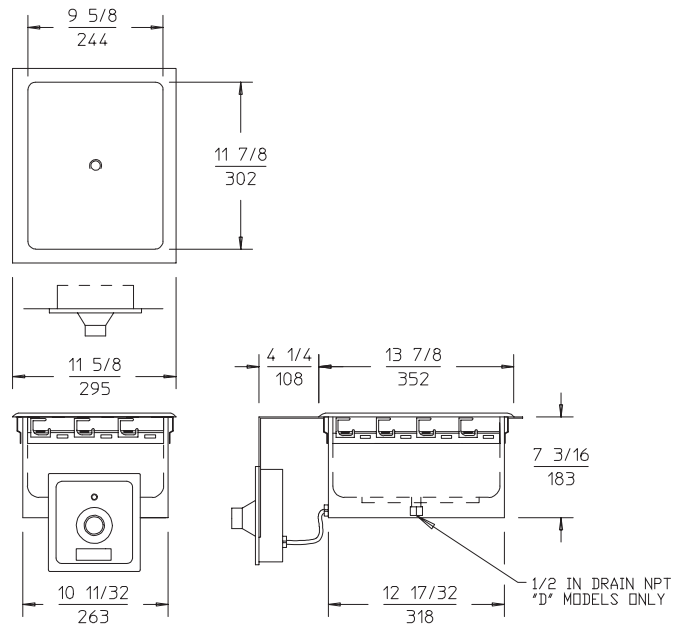

CLEARANCES

MINIMUM CLEARANCE REQUIRED UNIT TO THE NEAREST SURFACE			
BACK	SIDE	BOTTOM	FRONT
$\frac{1}{2}$ (25)	$\frac{2}{51}$ (51)	$6 \frac{3}{4}$ (171)	$4 \frac{1}{2}$ (114)

INSTALLATION INSTRUCTIONS

INSTALLER MUST MEET CONDITIONS OF ACCEPTABILITY OUTLINED BELOW UPON INSTALLATION:

1. Required installation clearances:

- Wooden and Metal Installation: DO NOT install closer than 4 1/2 inches to front wall, 1 inch to back, 2 inches to side wall, and 6 3/4 inches to surface below the unit.
 2. Unit shall be accessible for servicing from the bottom.
 3. If storage is to be used underneath the unit, it is recommended that a baffle be placed 8 1/2 inches below the unit to avoid contact with elevated temperatures.

TO FABRICATE:

- Layout cutout dimensions on countertop and front apron, shown in cutout details above.
- Cut and/or drill holes as required in countertop and apron.
- Must be accessible for servicing from the bottom.

TO INSTALL:

IMPORTANT - DO NOT disconnect lead wires from the Master Control Panel when making installation.

- Locate warmer and control over the counter cutout. Pass the control box through the opening, then mount the control box to the rear of the apron.
- Apply a bead of silicone adhesive/sealant to the gasket on the underside of the warmer flange, then seat warmer onto the countertop. Properly position.
- From underneath, insert screwdriver into "slots" on the E-ZLock frame and twist "ears" outward to secure flange tightly to countertop (see detail).
- Mount control box to apron cutout as shown in drawing.
- Mount control panel onto electrical box using the screws supplied.

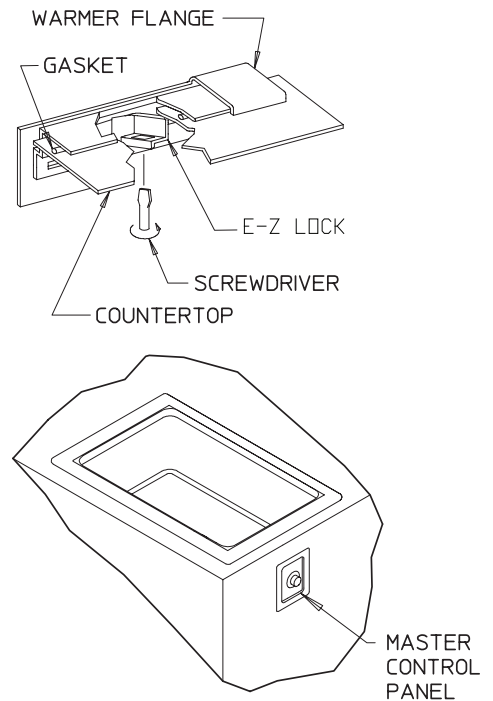

IMPORTANT:
MOUNT APPLIANCE SO THAT THE CONTROL PANEL IS LOCATED TO THE FRONT OF THE FIXTURE.