



Architect/Engineering Specifications:

Overhead swivel extension arm retrofit kit with 24" riser, 68" flexible stainless steel hose with heat resistant handle, 0.65 GPM angled spray valve, 3/8" NPT pipe coupling, Overhead swivel extension arm w/ adjustable tension balancer and 6" adjustable wall bracket. Certified to ASME A112.18.1/CSA B125.1, NSF 61-Section 9 and NSF 372. EPAAct 2005 compliant.

Job Name _____

Model Specified _____ Quantity _____

Variations Specified _____

Date _____

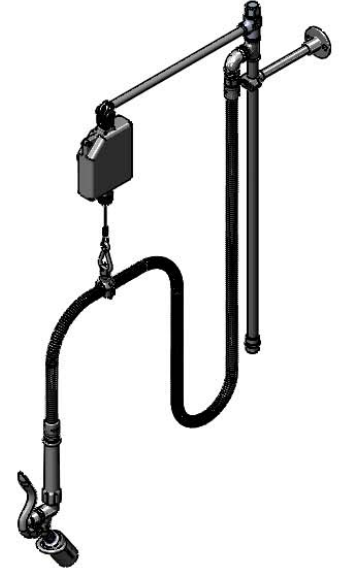
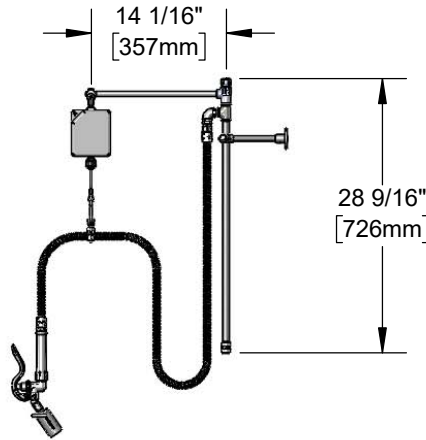

Features & Benefits:

- 24" riser
- 68" flexible stainless steel hose w/ heat resistant gray handle and hold down ring
- 0.65 GPM angled spray valve
- 3/8" NPT pipe coupling connects to existing risers
- Overhead swivel extension arm w/ adjustable tension balancer
- 6" adjustable wall bracket
- Material: Polished chrome plated riser, swivel arm & spray valve body and stainless steel hose

Product Compliance:

- ASME A112.18.1 / CSA B125.1
- NSF 61 - Section 9
- NSF 372 (Low Lead Content)
- EPAAct 2005 (PRSV)



Warranty: One Year (Limited)

Performance Data:

- Pressure: 20 - 125 psi
- Temperature: 40 °F - 140 °F
- Flow Rate: 0.65 GPM @ 60 psi

Optional Pre-Rinse Spray Valves

- B-0107 (1.42 GPM)
- B-0107-C (0.65 GPM)
- B-0107-J (1.07 GPM)
- B-0108 (1.07 GPM)
- B-0108-C (0.65 GPM)

