



# BEVERAGE-AIR®

## **INSTALLATION AND OPERATING INSTRUCTIONS** **for all Hydrocarbon** **VM Refrigerator Models**



809-167A Rev. A. 08/20/2024

3779 CHAMPION BLVD, WINSTON-SALEM, NC 27105

Phone: (888) 845-9800 | Fax: (800) 253-5168 | Web: [beverage-air.com](http://beverage-air.com)

**SEE BACK COVER FOR  
WARRANTY REGISTRATION**

## WELCOME

Thank you for purchasing a Beverage-Air cabinet. This series has passed our strict quality control inspection and meets the high standards set by Beverage-Air! You have made a quality investment that with proper maintenance will give you many years of reliable service!

Please read the following installation and maintenance **Important Information**

- PLEASE READ THESE INSTRUCTIONS CAREFULLY BEFORE INSTALLING OR USING, IF RECOMMENDED PROCEDURES ARE NOT FOLLOWED, WARRANTY CLAIMS MAY BE DENIED.
- Your warranty registration information is located within this manual. Please complete the card and submit it to Beverage-Air within TEN days of installation. Failure to properly register equipment may limit or void the warranty.

instructions before installing or using your unit. If you have any questions, Please call our Technical Service Department at **(800) 684-1199**. 8:00 AM to 5:00 PM EST.

- Beverage-Air reserves the right to change specifications and product design without notice. Such revisions do not entitle the buyer to corresponding changes, improvements, additions, or replacements for previously purchased equipment.

Safety .....	3
Important Information .....	6
Product Information .....	7
Clearance and Placement .....	8
Unpacking and Set Up .....	9
Electrical.....	10
Environmental Conditions.....	11
Positioning the Shelves and Loading the Unit.....	12
Cleaning and Maintenance .....	13
Methods For Cleaning Exerior Finish.....	14
Clearing the Drain Lines.....	15
Help.....	16
For The Service Tech - R290 .....	17
For The Service Tech - Wiring Diagram.....	18
Limited Warranty .....	21
Limited Warranty (continued).....	22

## SAFETY

This appliance has been designed with your safety in mind. It has many features to keep you from being harmed. However, safe operation and maintenance are your responsibilities. **USE THIS APPLIANCE FOR ITS INTENDED PURPOSE AS DESCRIBED IN THIS MANUAL.**



### Use: When using this unit, please:

- **Move it carefully.** If on casters be sure the casters do NOT run over the power cord.
- **Lock** the casters when in use.
- **Seek help.** This machine is heavy! Be sure to move with enough help to avoid tipping or dropping the cabinet.
- **Prevent children from playing in or on the cabinet.** Persons unable to use this product must be prevented access.
- **Follow all instructions.** There are many safety labels and directions on the unit. Heed them.
- **Watch your fingers.** There may be pinch points near the door hinges.



### Maintenance

#### Do NOT:

- Clean a frozen evaporator with a sharp object
- Clean a dirty condenser with a sharp object.
- Store or use gasoline, kerosene or any other flammable material near the cabinet.

#### Do ALWAYS

- Use a Beverage-Air recommended technician certified to repair R290 equipment.
- Use **ONLY** Beverage-Air factory service parts. Use of non OEM parts can be dangerous because of the design changes needed to safely use R290.

### Important Information to Add

Record the model number, serial number and the date of installation here for future reference. The model and serial numbers are on the unit's serial number dataplate, which is located on the left inside wall.

<b>Model Number</b>	
<b>Serial Number</b>	
<b>Date of Installation</b>	
<b>Purchased From</b>	



Observe the **Caution** and **Warning** notices. They are indicators of important safety information. Keep this manual for future reference.

**Using any electrical or electronic equipment entails the compliance with some fundamental rules.**

1. Do not touch the unit with wet hands or feet.
2. Do not install the equipment outdoors.
3. Do not remove or ignore safety devices.
4. Do not leave objects on top of the unit.
5. Do not climb on top of the unit.
6. Never use direct or indirect water jets on the unit.
7. Do not allow the electronic control to be adjusted by customers or unqualified personnel. For any adjustment, you must contact your distributor.
8. Verify that the hot air stream from the condenser toward the back of the unit is not directed to other refrigeration units, as this would compromise their operation.
9. Under no circumstance, should you block the front grille of the unit.
10. Use care when moving or handling the unit. It is equipped with flammable refrigerant and damage to refrigerant tubing will increase the risk of a leak.
11. When service is required, seek factory authorized technicians trained to safely maintain and service systems that utilize flammable refrigerants, such as R-290. RSES offers such training and certification.
12. Only use factory authorized replacement parts to minimize the risk of possible ignition.

**It is important to instruct the user on the operation of the equipment according to this instruction manual, and make sure that the manual is within reach of any operator that might use the unit.**

**THE MANUFACTURER DOES NOT ASSUME ANY RESPONSIBILITY ARISING FROM DAMAGES CAUSED BY IMPROPER, INCORRECT, OR ERRONEOUS USE.**



*CAUTION: If it is necessary to move the Refrigerator after removal from the skid, remove all doors and carefully push the unit at a point of no more than 36" from the bottom to avoid damage.*



Do NOT push in this area.

Push ONLY below the 36 inch / .91 meter height

## IMPORTANT INFORMATION

This unit is intended to be used in a commercial application. That includes bars and restaurants.

If installed in a residence some commercial service companies may not be able to service it on site.

The manufacturer has designed and produced this machine with the finest in materials. The manufacturer assumes no liability for units that have been altered in any way. Alterations or part substitutions will void the warranty.

### Limitations

The machine is designed for use indoors in a controlled environment. It must be kept dry, not overheated or subjected to excessive cold. May only be connected to a dedicated electrical circuit. Extension cords are not permitted.

	Minimum	Maximum
Voltage	102	127
Room Air Temp	60° F	85° F

### Air Flow

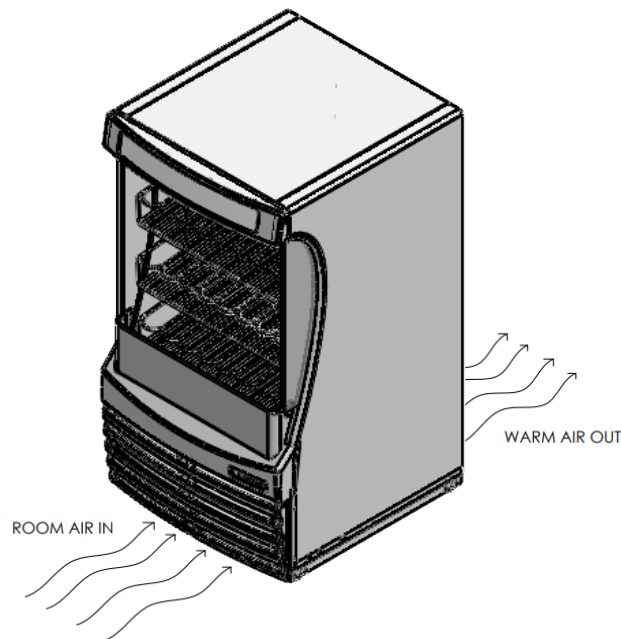

### Agency Approvals

These marks appear on the dataplate or serial tag, located in the inside of the left wall. The dataplate also contains the model and serial numbers as well as electrical requirements.



## PRODUCT INFORMATION

Model	Cabinet Dimensions w x d x h (Inches)	Full Load Amps	Power Cord Plug (NEMA)	Refrigerant Type / Charge (g) / Charge (oz)
VMHC-7-1	35 7/16 X 31 3/4 X 63 25/32	10	5-15P	R-290 / 126 / 4.25
VMHC-12-1*	35 1/4 X 31 3/4 X 83 5/32	12	5-20P	R-290 / 226 / 7.64
VMHC-18-1*	52 X 31 3/4 X 83 5/32	12	5-20P	R-290 / 270 / 9.13
VMHCSL-18*	47 7/16 X 24 9/32 X 83 1/2	12	5-20P	R-290 / 260 / 8.80

- Available in either white, or black vinyl wrapped exterior finish or grey powder coated steel.
- All models will maintain product temperature between 36 and 40 degrees F.
- Units with an (\*) have 2 systems
- All models are 120 volts, 60 Hz AC.
- ALWAYS REFERENCE YOUR EQUIPMENT DATA PLATE AMPS, REFRIGERANT AND REFRIGERANT CHARGE FOR THE MOST UP TO DATE AND ACCURATE VALUES.
- There are no access valves on the refrigeration system.

## CLEARANCE AND PLACEMENT

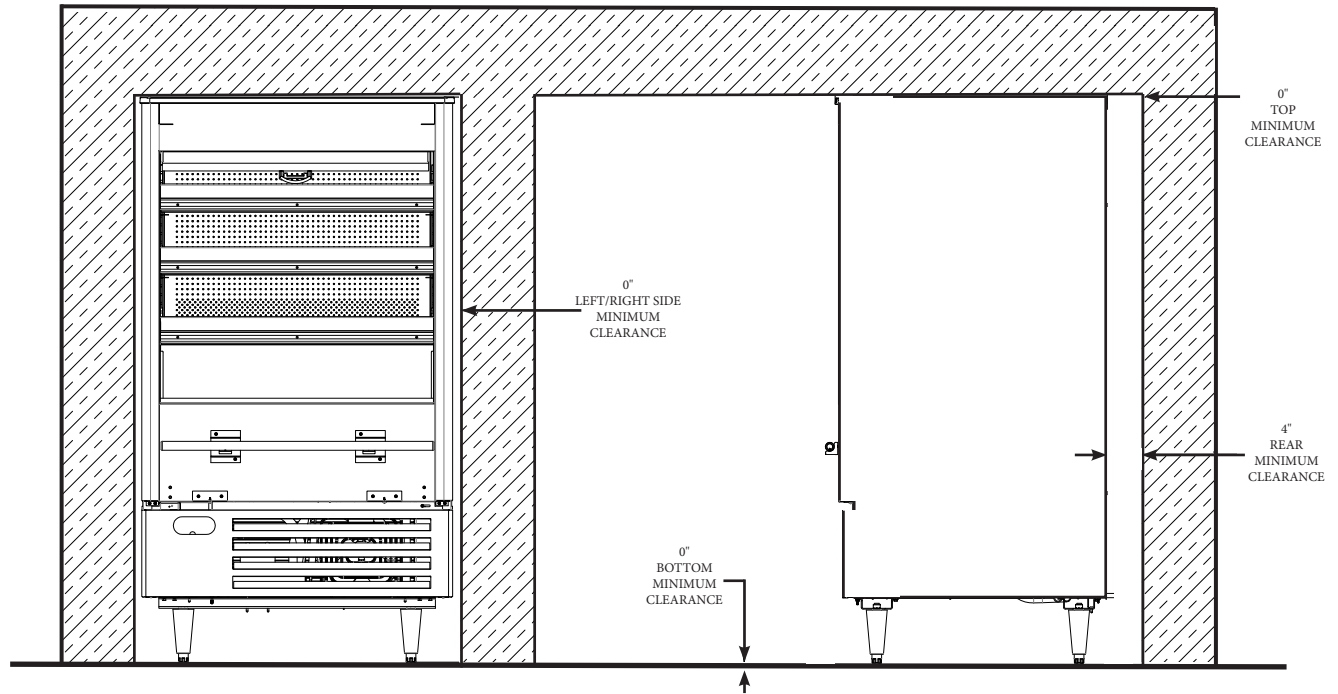

### Placement

Consider the following when selecting a location for your Refrigerator:

#### Clearance:

- 0.0 in. at the top
- 4.0 in. at the rear,
- 0.0 in. at the left side
- 0.0 in. at the right side
- 0.0 in at the bottom

**Floor Load:** the floor on which the Refrigerator is located must be even and level, free from vibrations, and strong enough to support the combined weights of the unit and maximum product load.

**Ventilation:** Grille area at front must be free and clear of any object or wall.

**Power Outlet:** Dedicated power outlet is located within the length of the unit's power cord.



## UNPACKING AND SET UP

Carefully inspect the shipping carton for damage. This is the only time that shipping damage may be claimed. If damage is suspected, open the carton immediately and, if there is damage, retain the carton and contact the shipper to make a claim. Do NOT contact the manufacturer.

### Uncrating

Tools Needed:  $\frac{3}{4}$ " box wrench, adjustable wrench, level, flat head screw driver, and box cutter.

1. Cut the stretch wrap along a corner post and remove the cardboard top capping and the corner posts.
2. Discard stretch wrap and any cardboard that will not be recycled.

---

*Note: additional clear plastic protective wrap is applied directly to any product with a glass door.*

---

3. Move unit as close to final position as possible before removing the skid.

---

*Note: The skid must be removed before the casters or legs can be attached.*

---

**Do NOT tip unit on its front or sides. If tipped onto the back, unit must not be started for 3 hours.**

### Skid Removal and Caster Attachment

Tip the unit forward and remove the skid.



1. Remove the shipping bolts using the  $\frac{3}{4}$ " box wrench while cabinet is held in one direction. Repeat the process while the cabinet is held in the opposite direction.
2. None of the threads on the leg or caster stem should be visible once screwed in.
3. Tilt the cabinet in one direction approximately 8" and block it securely with pieces of 2x4 lumber or other suitable material.

4. While moving the unit, take extra caution to not push, pull, or strike the front or side glass.

### Leveling:

Cabinets must be leveled when installed. Level should be measured on the headrail.

---

*Note: If no casters, legs or levelers are to be installed, the floor below the equipment must be level*

---

Failure to level your cabinet may result in door not sealing, closing correctly, or condensed water draining not draining properly.

For cabinets with legs, rotate the foot of the leg with an adjustable wrench to achieve desired height for leveling.

For cabinets with casters, leveling can be achieved by placing large washers in between the  $\frac{1}{2}$ " stud and the holes located on the bottom of the case.

**Do NOT loosen casters to level the cabinet.** Casters MUST be tightly secured to cabinet for full strength.

Install or attach any accessories that will be used. Remove any plastic covering the stainless steel.



## ELECTRICAL

This is a cord-connected unit, and must be connected to its own **dedicated** power supply. Check the dataplate on the machine to confirm the voltage and per the dataplate use the correct fuses or HACR circuit breakers.

---

*Note: Do not connect to GFI / GFCI outlets. Connection to that type of outlet can result in product loss due to unsafe cabinet temperature when GFI device trips from moisture.*

---

### Power Cord

This 120 volt model is equipped with a cord and either 5-15P or 5-20P plug.

If the power cord becomes damaged, it must be replaced with the identical cord.

### Follow All National and Local Codes

This Unit Must Be Grounded. Do not use extension cords and do not disable or by-pass ground prong on electrical plug.

### Initial Start Up

Plug the power cord into the proper power supply.

The cabinet will soon begin to blow warm air out of the top area, and cool air will flow from the inside blower.

The cabinet temperature has been set at the factory at 34°F and should not be adjusted by unqualified personnel. For any adjustment, you must contact your distributor.

### Cautions

Care must be taken whenever moving or servicing the unit. The refrigerant is contained in a sealed system, but if released it may be flammable.

### Electronic Temperature Control

The unit is provided with an electronic temperature control which controls the operation of the unit based on the temperature of the air entering the evaporator at the front of the unit. In order to achieve the desired product temperature, the electronic control is factory adjusted to turn off the refrigeration system at 35°F and start it at 39.5°F.

When you plug the unit in, the control display will illuminate. However, there is a start-up delay of two minutes before the compressor(s) are energized. This delay avoids the possibility that during a power failure, the compressors are forced to restart before the refrigerant pressures are equalized.

The control has been factory-adjusted with a defrosting cycle scheduled to last 6 minutes every hour to ensure that the evaporator performs without any ice build-up.

None of the factory-programmed electronic control parameters can be modified unless an access code is entered (only your distributor's technical personnel have that code).

## ENVIRONMENTAL CONDITIONS

**THIS UNIT CANNOT BE INSTALLED IN ENVIRONMENTS WITH EXPLOSIVE GASES, IT IS DESIGNED ONLY FOR INDOOR OPERATION.**

### Storage of the equipment:

If the equipment will be kept in storage, it is suggested to keep it in its original packing. If your equipment needs to be inactive for a long period of time, it should be unplugged and cleaned thoroughly with a damp cloth, lukewarm water, and neutral soap. Once clean, carefully dry the unit and cover it with a polyethylene film or similar waterproof material.

The unit must be located in an indoor environment less than 75°F and 55% room humidity.

It is important to leave at least 4" of free space at the back to allow proper air circulation.

Care must be taken to ensure that air drafts around the cooler are kept to a minimum. A minimum space must be kept between the cooler and air sources such as air conditioner supplies or return grilles, vent hoods, appliance condenser air intake and discharge, outside doors, fans, or other air movement devices.

The location of the cooler must be kept away from sources of heat and humidity including direct sunlight, ovens, heaters, or any other heat generating appliances.

The unit should be leveled prior to operation using either casters, 6" legs, or sealed per NSF guidelines shown in fig. 1 and 2.

**The following horizontal distance should be considered minimums unless special precautions are taken:**

- 5' from appliance condenser air intake and discharge
- 10' from air conditioner supply or return grilles
- 10' from vent hood
- 15' from open doors

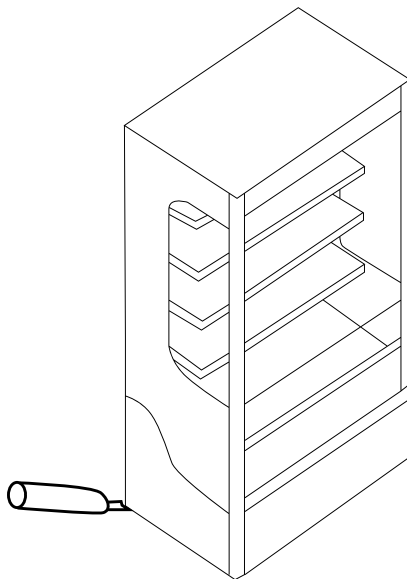

**FIGURE 1**

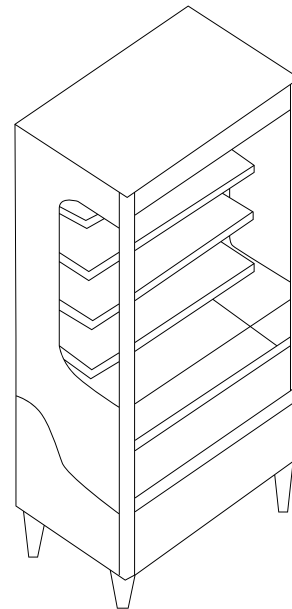

**FIGURE 2**

## POSITIONING THE SHELVES AND LOADING THE UNIT

### POSITIONING THE SHELVES

The shelves and holders have been fixed to the inside floor of the unit to prevent their loss during transportation.

Insert the shelf brackets in the pilaster notches making sure they are at the same level such that the shelves remain horizontal.

### LOADING THE UNIT

This equipment has been exclusively designed to maintain the proper temperature of packaged fresh food and beverages. They are not pull down refrigerators, and as such, the product must be loaded at their intended merchandising temperature.

Before loading product into the unit, allow it to run empty for at least two hours.

When loading product:

- Do not block the lower ventilation grille with the packages while loading (see fig 3).
- Do not block the return vents that ensure a proper refrigerated air circulation (see fig 4).
- Do not over hang the shelves.
- Do not press the product against the rear wall.
- Do not keep the unit running while empty. Unplug it when it is not in use.

To prevent potential damage to the unit and/or injury, never exceed the shelf weight limits in the table below

MODEL NO.	MAX WEIGHT PER SHELF
VMHC-7-1	110 LBS / 50 KG
VMHC-12-1	110 LBS / 50 KG
VMHC-18-1	132 LBS / 60 KG
VMHCSL-18-1	110 LBS / 50 KG

**IMPORTANT: THE PRODUCT ON EACH SHELF MUST LEAVE AT LEAST 1-2 INCHES OF FREE CLEARANCE BETWEEN THEM AND THE NEXT SHELF IN ORDER TO ALLOW PROPER AIR CIRCULATION.**

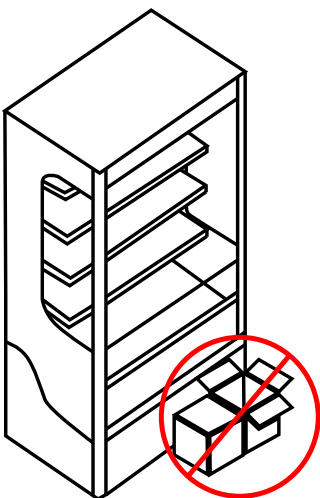

**FIGURE 3**

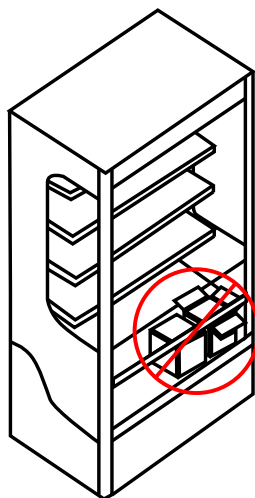

**FIGURE 4**

## CLEANING AND MAINTENANCE

### Cleaning Schedule:

Cabinet	Condenser coil	Gaskets	Routine maintenance
Daily wipe down	Quarterly cleaning	Daily inspection, check that hinges are tight to the cabinet.	Annually
Weekly interior			

Regularly and carefully cleaning the equipment prevents deterioration and product alteration. It is much easier to clean on a regular basis than to have to remove stains once they have built up.

NEVER USE FLAMMABLE OR ABRASIVE PRODUCTS. THE UNIT MUST NEVER BE CLEANED WITH WATER JETS. DURING MAINTENANCE AND CLEANING OPERATIONS, MAKE SURE THAT GOOD VISIBILITY CONDITIONS EXIST IN THE WORKING AREA, USING OTHER LIGHT SOURCES IN CASE IT IS NEEDED. BE VERY CAREFUL WHEN WORKING WITH MOVING AND/OR HIGH TEMPERATURE PARTS.

### Daily Exterior Cleaning

1. Wash with a damp piece of cloth and neutral soap.
2. Rinse with clean water.
3. Dry with a soft cloth.

### Weekly Interior Cleaning

1. Remove all contents and shelves. Do not remove grilles or panels that require using tools, this should be done by an authorized technician.
2. Store the food at a safe temperature while the unit is being cleaned.
3. Disconnect power to the unit (unplug it or switch the breaker off).
4. Remove all loose food particles from the inside walls, floor, door liner and ceiling.
5. Clean all interior surfaces with a damp piece of cloth and neutral soap.
6. Wipe again with a clean, dry cloth and allow to air dry.
7. Return the shelves to the unit and secure them.
8. Restore power.
9. Return food to the unit when it has reached a safe temperature.

### Cleaning the Condenser Coil

1. Disconnect power to the unit
2. Take off front lower grill assembly by removing the two (2) screws in the top corners.
3. Clean off accumulated dirt from the condenser coil(s) using a vacuum and/or damp rag
4. Replace the grille assembly.
5. Connect power to the unit and verify that when required, the condensing unit(s) are running.
6. If you cannot remove the dirt adequately, please call your refrigeration service company.

## METHODS FOR CLEANING

Cleaning Needed	Cleaning Agent	Method of Application	Affect on Finish
Smears and fingerprints	Areal 20, Lac-O-Nu, Lumin Wash O'Cedar Cream Polish, Stainless Shine.	Rub with cloth as directed on the package.	Satisfactory for use on all finishes. Provides barrier film to minimize prints.
Stubborn Spots and Stains, and Other Light Discolorations	Allchem Concentrated Cleaner.	Apply with damp sponge or cloth. Rub with damp cloth.	Use in direction of polish lines on No. 4 (polished) finish. May scratch No. 2 (mill) and Nos. 7 and 8 (polished) finishes.
	Samae, Twinkle or Cameo Copper Cleaner	Rub with damp cloth.	
	Grade FFF Italian pumice, whiting, or talc.	Rub with dry cloth.	
	Liquid NuSteel Paste NuSteel or DuBois Temp. Copper's Stainless Steel Cleaner Revere Stainless Cleaner Household cleansers, such as Old Dutch, Lighthouse, Sunbrite, Wyandotte, Bab-O, Gold Dust, Sapolio, Bon Ami, Ajax, or Comet Grade F Italian Pumice, Steel Bright, Lumin Cleaner, Zud, Restore, Sta-Clean, or Highlite. Penny-Brite or Copper-Brite.	Use small amount of cleaner. Rub with dry cloth using a small amount of cleaner. Apply with damp sponge or cloth. Rub with a damp cloth. May contain chlorine bleaches. Rinse thoroughly after use. Rub with a damp cloth. Rub with a dry cloth using a small amount of cleaner.	
Heat tint or discoloration	Penny-Brite or Copper-Brite. Past NuSteel, DuBois Temp, or Tarnite. Revere Stainless Steel Cleaner. Allen Polish, Steel Bright, Tenacious Deposits, Rusty Discolorations, Industrial Atmospheric Stains Wyandotte, Bab-O or Zud.	Rub with a dry cloth. Rub with a dry cloth or stainless steel wool. Apply with damp sponge or cloth. Rub with a damp cloth.	
Grease Fatty Acids, Milkstone (where swabbing or rubbing is not practical)	Easy-Off, De-Grease-It, 4 to 6% hot solution of such agents as trisodium phosphate or sodium tripolyphosphate or 5 to 15% caustic soda solution	Apply generous coating. Allow to stand for 10-15 minutes. Rinse. Repeated application may be necessary.	Excellent removal, satisfactory for use on all finishes.
Tenacious Deposits, Rusty Discolorations, Industrial Atmospheric Stains	Oakite No. 33, Dilac Texo 12, Texo NY, Flash-Klenz, Caddy Cleaner, Turco Scale 4368 or Permag 57.	Swab and soak with clean cloth. Let stand 15 minutes or more according to directions on package, then rinse and dry.	Satisfactory for use on all finishes
Hard Water Spots and Scale	Vinegar. 5% oxalic acid, 5% sulfamic acid, 5 to 10% phosphoric acid, or Dilac, Oakite No. 33, Texo 12, Texo N.Y.	Swab or wipe with cloth. Rinse with water and dry. Swab or soak with cloth. Let stand 10-15 minutes. Always follow with neutralizer rinse, and dry.	Satisfactory for all finishes. Satisfactory for all finishes. Effective on tenacious deposits or where scale has built up.

## CLEARING THE DRAIN LINES

It is likely that over time the drain lines will become clogged, which will result in water overflowing the condensate pan onto the floor. This is a standard maintenance item and will not be covered under warranty.

The drain lines can also be accessed by removing the bottom panel from inside the unit (fig. 5). Both holes for the drain lines can be located (fig. 6).

Obstructions can be removed either by compressed air or nitrogen, or by physically removing the obstruction with a drain cleaner.

**DO NOT USE A CHEMICAL DRAIN CLEANER, AS THIS WILL VOID THE WARRANTY**

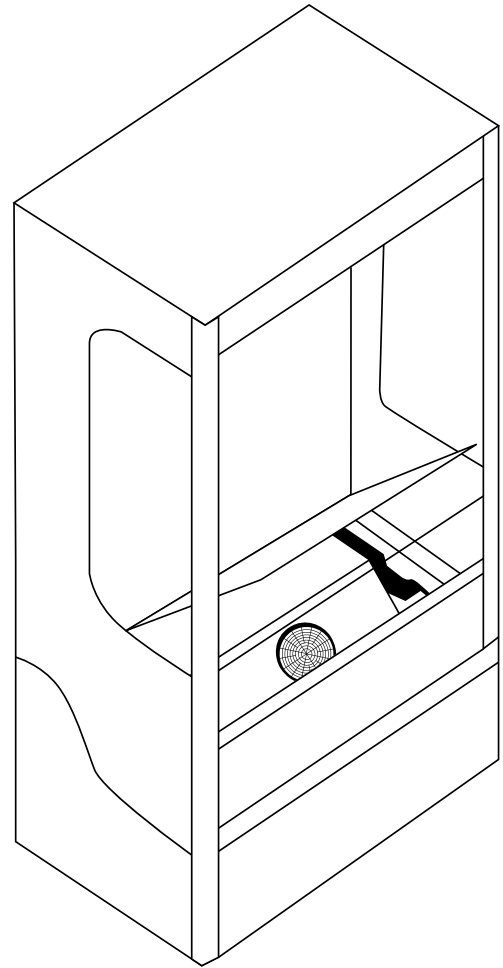

**FIGURE 5**

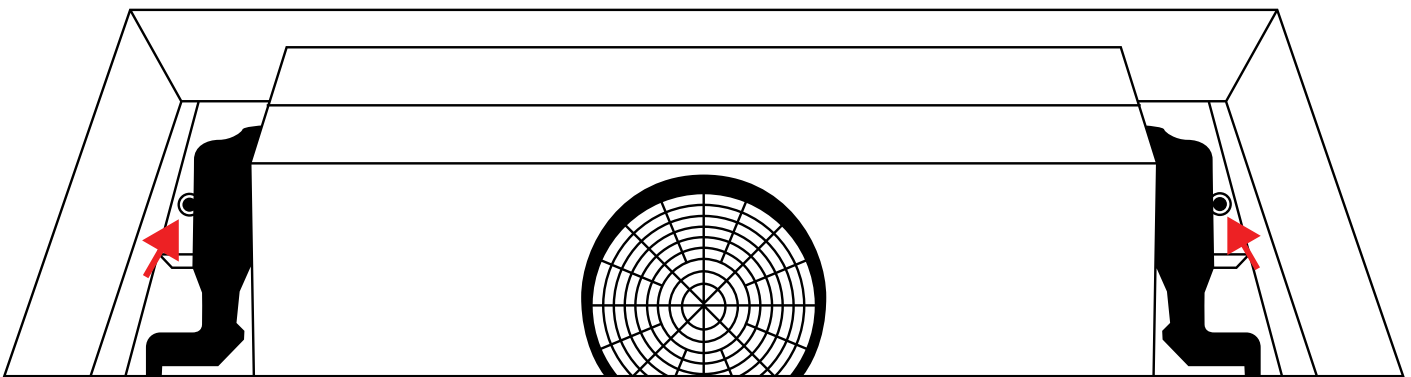

**FIGURE 6**

## HELP

Trouble Diagnosis for the User		
Malfunction	Possible Cause	Likely Solution
No cooling - unit is silent	Unit not plugged in. Fuse or circuit breaker tripped. Power cord plug loose in outlet.	Connect to proper voltage circuit Replace fuse or reset breaker. Check outlet for loose connection, replace as needed
Unit cools but seems to be on all the time	Dirty condenser	Clean condenser
Space temperature too high	Dirty condenser Evaporator iced over Unit in high temperature environment	Clean condenser Defrost evaporator Reduce temperature of room
Space temperature too low	Temperature control	Adjust or replace control
Trouble Diagnosis for the Technician		
No cooling - compressor does not hum	Temp control stuck in open position	Replace temp control.
No cooling - compressor hums but does not start	Low voltage to unit. Compressor starting system failure	Check voltage, correct as needed. Check start relay and start capacitor. See next step.
No cooling - compressor starts but shuts off	Compressor start relay failure Compressor start capacitor failure	Replace relay. Replace capacitor.
No cooling - compressor cycles on and off	Overheating weak overload	Clean condenser, check fan motor and blade. Check refrigerant charge. Replace overload.
Unit cools, but is slow to pull cabinet temperature down	Evaporator fan not turning	Check fan(s), on multiple fan units one fan may be turning slowly and will need to be replaced.
Unit cools but turns on and off frequently	No product in cabinet. Temperature control defective Refrigeration issue	Fill cabinet Replace control Have system checked
Makes excessive noise	Tubing rattle Loose parts Bent or broken fan blade Noisy fan motor	Check tubing for routing Check for loose components Replace fan blade Replace fan motor



## FOR THE SERVICE TECH - R290

Refrigeration service should only be attempted by a trained trade professional certified to work on R290 systems.

### Here are some critical service items.

This list does not qualify anyone to service the unit. It is a reminder and checklist for the service tech. Keep these in mind for R290 service:

- Wire nuts are NOT to be used when changing an electrical part.
- The switches in this product are sealed, **only exact replacements** may be used.
- The process tubes are to be used for service access.
- Cut out (with tubing cutter) refrigeration components that are to be replaced. Do NOT un-braze.
- Because R290 can be vented into the air during service, the venting **MUST** be in an area free from flame or spark. It must be near an opened window or door.
- A sign noting service of a system containing propane must be attached to the unit during refrigeration service.
- A combustible gas leak detector must be used to inform anyone in the area when propane is present in the air.

### Mechanical Components:

- The units will have either one or two compressors that will start in two steps, with a delay of ten seconds to reduce the rush of current into the unit.
- These units incorporate a "maintenance free" condenser design in the refrigeration system which reduces the need for the regular cleaning process that fin and tube condensers require. Besides the savings in preventive maintenance costs, energy expenses will be stable throughout long periods of time since the condensers will remain "clean and unobstructed".
- In the event it is believed that the unit has had a "freeze up" condition due to operation of the unit in high temperature or humidity conditions, the evaporator can be inspected by removing the floor of the inside of the unit. In the event the evaporator is frozen, it can be thawed by emptying the cabinet of all contents and removing power until the coil is clear.
- When the equipment operates, condensed water from the environment is collected on the evaporator. During each off-cycle, the water drains to the evaporator tray located at the bottom of the unit, where it is evaporated using the heat from the refrigeration system.
- The condensing unit can be pulled out, sliding it approximately 16" to allow servicing the condenser motor(s), compressor(s), and other electrical components. In order to service the condensing unit, remove the two screws that hold the lower front grille (one at each side). Remove the screws that hold the front bracket that clasps the condensing unit and slide it out gently to have access to the components you want to check. Once completed, ensure that every component has been returned to it's original location for proper operation.
- The lamp can be turned off with the switch located at the left side of the upper section, near the lamp.
- The night curtain should be closed whenever the unit is not required for actively merchandising products.



## FOR THE SERVICE TECH - WIRING DIAGRAM - VMHC-12, VMHC-18

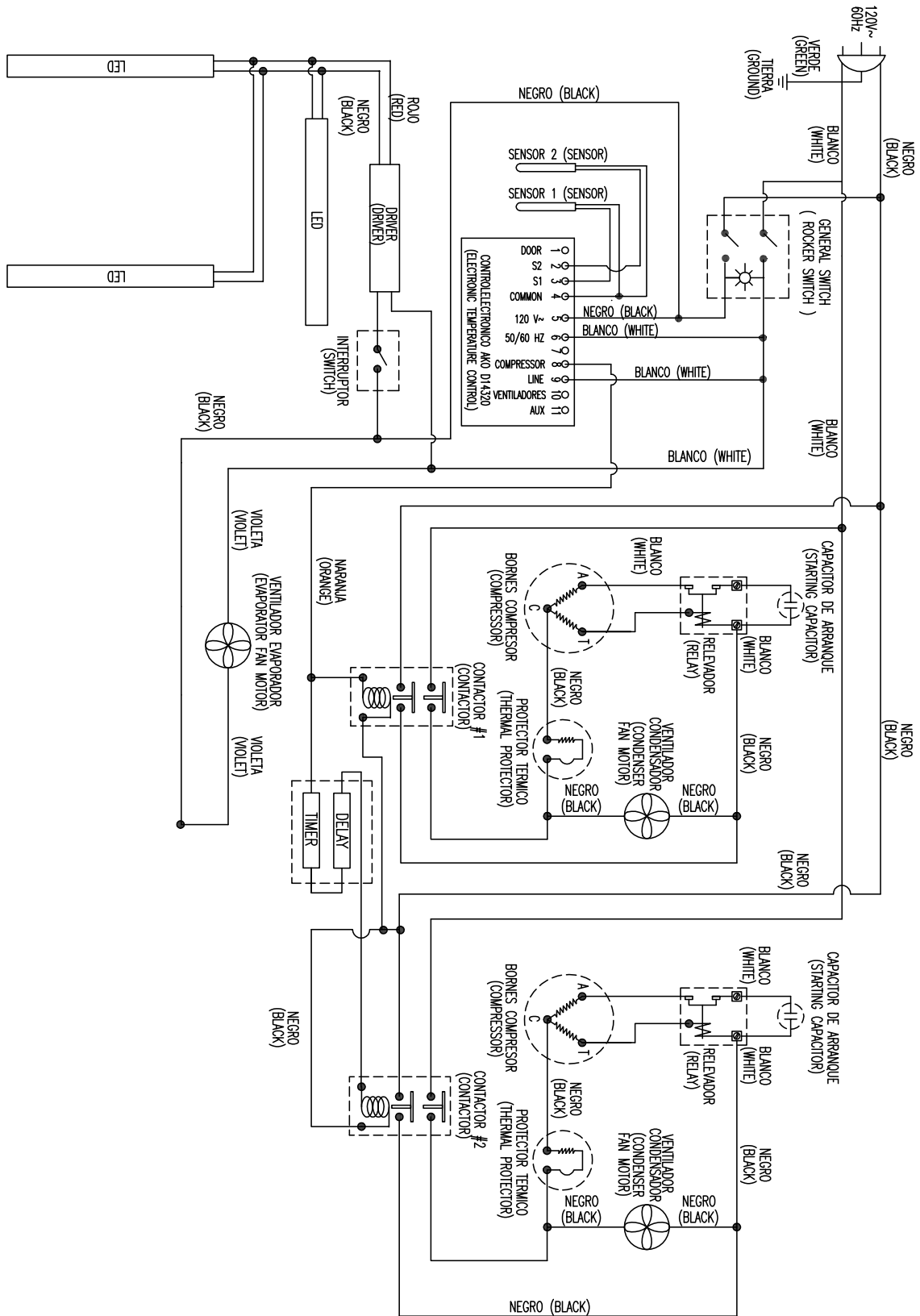

## FOR THE SERVICE TECH - WIRING DIAGRAM - VMHCSL-18

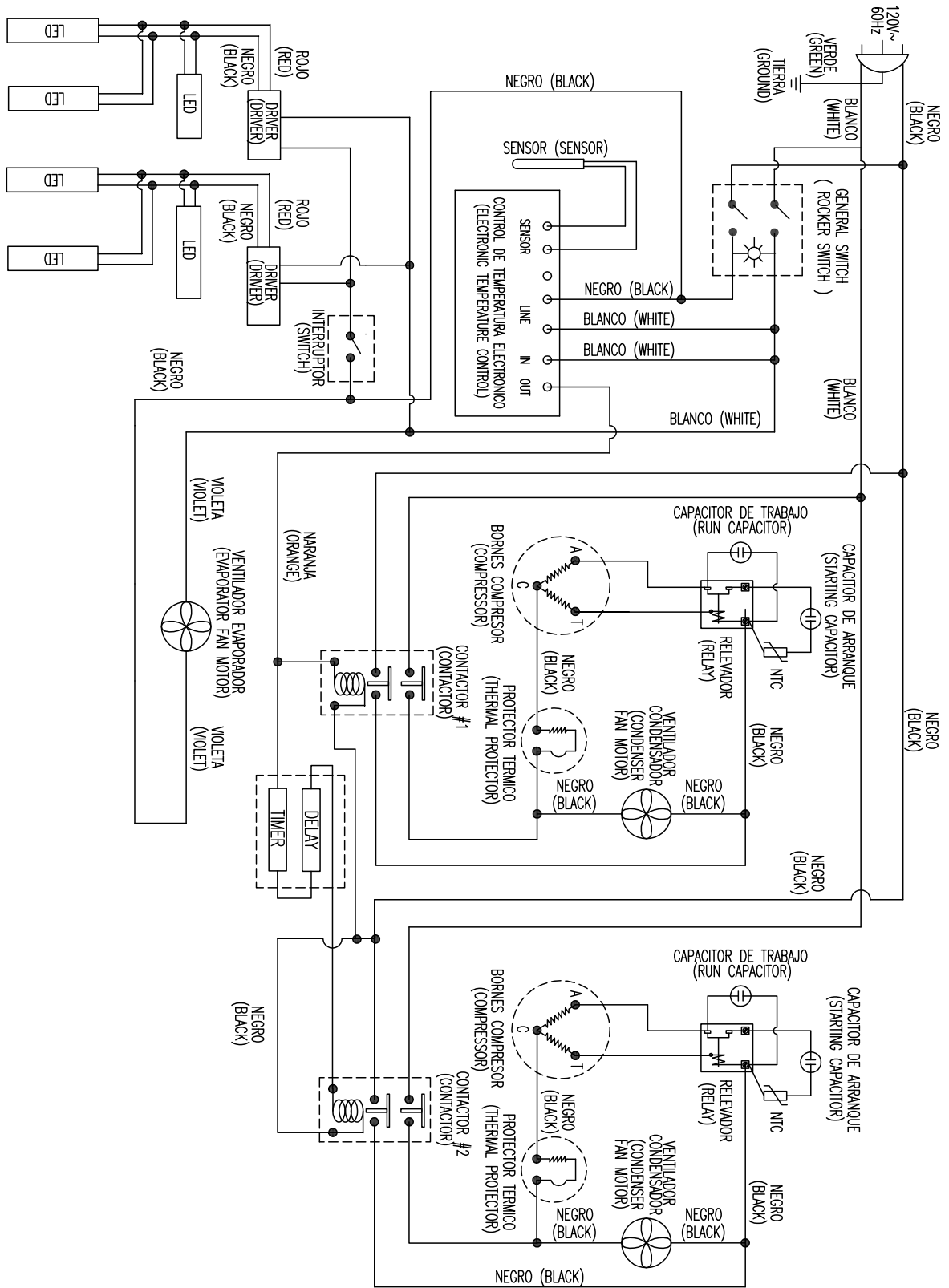

## LIMITED WARRANTY

### WARRANTY (Warranty valid in USA and Canada)

#### THREE (3) YEAR PARTS AND LABOR WARRANTY:

Beverage-Air Corporation warrants to the original purchaser of Beverage-Air branded equipment, including all parts thereof, that such equipment is free from defects in material and workmanship, under normal use, proper maintenance, and service as indicated by Beverage-Air installation and operation instructions, for a period of three (3) years from the date of installation, or thirty-nine (39) months from the date of shipment from the manufacturer, whichever is earlier.

#### ADDITIONAL TWO (2) YEAR COMPRESSOR PART WARRANTY\*:

In addition to the warranty set forth above, Beverage-Air warrants the hermetically/semi-hermetically sealed compressor (part only) for an additional TWO (2) years beyond the first THREE (3) years warranty period; not to exceed sixty-three (63) months from the date of shipment from Beverage-Air, provided upon receipt of the compressor, manufacturer examination shows the sealed compressor to be defective. This extended warranty does not cover freight for the replacement compressor or freight for the return of the failed compressor.

\* Units shipped after 07/01/2024. Previous warranty applies to units shipped prior.

#### EXCEPTIONS:

- CT96 and CF3 models carry a ONE (1) year parts and labor warranty, limited to fifteen (15) months from date of shipment from Beverage-Air. These are excluded from additional compressor warranty.
- SR/SF (Slate) models carry a TWO (2) year parts and labor warranty, limited to twenty-seven (27) months from date of shipment from Beverage-Air.
- BZ, VM, CDR, DPCR, MT and Blast Chillers carry a THREE (3) year parts and labor warranty; additional TWO (2) years compressor part only.
- Units installed in Residential applications will be not covered under this warranty. Units are intended for Commercial use only.

Also, this compressor-part only warranty does NOT apply to any electrical controls, condenser, evaporator, fan motors, overload switch, starting relay, capacitors, temperature control, filter/drier, accumulator, refrigeration tubing, wiring harness, labor charges, or supplies which are covered by the warranty above.

Note: 3rd party extended warranties are not covered by this warranty statement.

Normal wear parts, as deemed by Beverage-Air, such as but not exclusive to, light bulbs/lamps and gaskets are not covered by this warranty. For the purpose of this warranty, the original purchaser shall be deemed to mean the individual or company for who the product was originally installed.

Units that utilize variable speed compressor technology can experience nuisance tripping on Class A GFCI outlets which have a trip limit of 4 mA to 6 mA. To avoid this issue in a location that requires GFCI circuit protection, Beverage-Air & Victory recommends using a HUBBELL Model Number GFRST83W 20A Heavy Duty Hospital Grade Self-Test GFCI Receptacle. Nuisance tripping not covered under warranty.

Our obligation under this warranty shall be limited to repairing or replacing, including labor, any part of such product, which proves thus defective. Beverage-Air reserves the right to examine any product claimed to be defective and request photos of the unit prior to dispatching service. Moisture or water damage is not covered under warranty. If service is deemed non-warranty, Beverage-Air reserves the right to bill the end user for service.

The labor warranty shall be for self-contained units only and for standard straight time, which is defined as normal service rate time, for service performed during normal working hours. All warranty labor will be covered at standard time. Any service requested outside of a servicer's normal working hours including weekends and any additional overtime will be at the responsibility of the equipment purchaser. Any part or accessory determined to be defective in the product should be returned to the company within thirty (30) days under the terms of this warranty and must be accompanied by a record of the cabinet model, serial number, and identified with a return material authorization number (RMA#) issued by the manufacturer.

**Special installation/applications, including remote locations, are limited in coverage by this warranty. Any installation that requires extra work, and/or travel, to gain access to the unit for service is the sole responsibility of the equipment purchaser.**

Improper operation resulting from factors, including but not limited to, improper or negligent cleaning and maintenance, improper installation, low voltage conditions, inadequate wiring, outdoor use (unless otherwise specified) and accidental damage are not manufacturing defects and are strictly the responsibility of the purchaser.

**LIMITED WARRANTY (CONT'D)**

With the exception of Blast Chillers, the product is designed for maintaining temperature and not bringing food to a desired temperature and therefore cannot be held responsible for this function under warranty. Units must be in a conditioned environment or warranty will be void. Non-standard use of unit can also be subject to reduced or voided warranty.

Condensing coils must be cleaned at regular intervals as a part of preventative maintenance for optimal performance. Failure to do so is subject to a voided warranty. Although cleaning requirements vary in accordance with operation of various products, Beverage-Air recommends a minimum monthly cleaning.

**NO CLAIMS CAN BE MADE AGAINST THIS WARRANTY FOR SPOILAGE OF FOOD, PRODUCTS, LOSS OF SALES OR CONSEQUENTIAL DAMAGES.**

THE FOREGOING WARRANTIES ARE EXPRESSLY GIVEN IN LIEU OF ALL OTHER WARRANTIES, EXPRESS, IMPLIED, OR STATUTORY, INCLUDING THE IMPLIED WARRANTIES OF MERCHANTABILITY AND FITNESS FOR A PARTICULAR PURPOSE, WHICH ARE HEREBY DISCLAIMED, ALL OTHER OBLIGATIONS OR LIABILITIES ON OUR PART, AND WE NEITHER ASSUME, NOR AUTHORIZE ANY OTHER PERSON TO ASSUME FOR US, ANY OBLIGATION OR LIABILITY IN CONNECTION WITH THE SALE OF SAID REFRIGERATION UNITS OR ANY PARTS THERE OF.

This warranty shall not be assignable and shall be honored only in so far as the original purchaser. This warranty does not apply outside the limits of the United States of America and Canada, nor does it apply to any part that has been subject to misuse, neglect, alteration, accident, or to any damage caused by transportation, flood, fire, acts of terrorism, or acts of God.

**LIMITATION OF LIABILITY:**

Beverage-Air Corporation or their affiliates shall not be liable for any indirect, incidental, special or consequential damages, or losses of a commercial nature arising out of malfunction equipment or its parts components thereof, as a result of defects in material or workmanship.

THE ORIGINAL OWNER'S SOLE AND EXCLUSIVE REMEDY AND BEVERAGE-AIR'S SOLE AND EXCLUSIVE LIABILITY SHALL BE LIMITED TO THE REPAIR OR REPLACEMENT OF PARTS OR COMPONENTS CONTAINED IN THE EQUIPMENT IDENTIFIED ABOVE WHICH UNDER NORMAL USE AND SERVICE MALFUNCTION AS A RESULT OF DEFECTS IN MATERIAL OR WORKMANSHIP, SUBJECT TO THE APPLICABLE PROVISIONS AND LIMITATIONS STATED ABOVE.

Note: Additional Terms and Conditions of sale may apply. Notice: Specifications are subject to change without notice. Contact Beverage-Air for specific model agency approval. All prices are ex-works Brookville, PA. July 1, 2024

**Warranty Registration**

Register your product online at [beverage-air.com/parts-service](http://beverage-air.com/parts-service) or fill out and mail the form below.

Cabinet Model Number: \_\_\_\_\_ Date Of Installation: \_\_\_\_\_

Cabinet Serial Number: \_\_\_\_\_

**Location Of Product**

Business Name: \_\_\_\_\_

Business Street: \_\_\_\_\_

Business City: \_\_\_\_\_ State: \_\_\_\_\_ Postal Code: \_\_\_\_\_

**Mail to:** Beverage-Air, 3779 Champion Blvd, Winston-Salem, NC 27105

Rev. 08/24

