



OPERATOR MANUAL

IMPORTANT INFORMATION, KEEP FOR OPERATOR

1055 Mendell Davis Drive, Jackson, MS 39272
888-994-7636, fax 888-864-7636
unifiedbrands.net



THIS MANUAL MUST BE RETAINED FOR FUTURE REFERENCE. READ, UNDERSTAND AND FOLLOW THE INSTRUCTIONS AND WARNINGS CONTAINED IN THIS MANUAL.

FOR YOUR SAFETY Do not store or use gasoline or other flammable vapors and liquids in the vicinity of this or any other appliance.

WARNING Improper installation, adjustment, alteration, service or maintenance can cause property damage, injury or death. Read the installation, operating and maintenance instructions thoroughly before installing or servicing this equipment.

NOTIFY CARRIER OF DAMAGE AT ONCE It is the responsibility of the consignee to inspect the container upon receipt of same and to determine the possibility of any damage, including concealed damage. Unified Brands suggests that if you are suspicious of damage to make a notation on the delivery receipt. It will be the responsibility of the consignee to file a claim with the carrier. We recommend that you do so at once.

Manufacture Service/Questions 888-994-7636.

This manual provides information for:

ERGONOMIC TILTING BRAISING PAN MODELS BPM-15/30/40E(C,A,C2T™) & BPP-30/40E(C,A,C2T™)



REFERENCES

NFPA/70 - The National Electrical Code
NSF/ANSI - Standard 4
UL/ANSI - Standard 197

NSF INTERNATIONAL
789 N. Dixboro Road
P.O. Box 130140
Ann Arbor, Michigan 48113-0140

NATIONAL FIRE PROTECTION ASSOCIATION
60 Battery March Park
Quincy, Massachusetts 02269

UNDERWRITERS LABORATORIES, INC.
333 Pfingsten Road
Northbrook, Illinois 60062

EQUIPMENT DESCRIPTION

The BPM/BPP is a stainless steel, electrically heated Braising Pan which is equipped with integrated heating elements, a hand operated or motor powered tilting mechanism, electronic controls and a hinged cover. The Braising Pan serves as a braising unit, griddle, fry pan, oven, kettle, bain-marie, or food warmer and server. It can also be adapted for use as a non-pressure steamer.

The pan body is constructed of heavy-duty stainless steel, welded into a solid piece. It has a polished interior and exterior finish. A pouring lip is welded to the top of the front wall. The cooking surface is a stainless steel clad plate fitted with clamped-on electrical heating elements. The elements are positioned to ensure uniform heat transfer over the entire surface.

Pans are mounted on an open-leg frame which is fabricated from tubular stainless steel.

An easily operated worm and gear mechanism tilts the pan body and provides precise control for pouring or dumping its contents. This tilting mechanism is located in a stainless steel console to right of the pan body. For power tilt units a three position switch on the front of the control console gives the operator positive, smooth-acting control of tilt. To facilitate cleaning, the pan body can be tilted past the vertical position.

Heating elements and other electrical components are enclosed for safety. The temperature controller, heating indicator light and tilting switch are

contained in a compact control console which is mounted to the right of the pan body.

The temperature controller provides automatic control of cooking temperature. Turning the temperature dial starts and stops heating and sets the pan temperature. Only one electrical connection is required to install the unit.

A heavy gauge, one-piece, stainless steel cover with a rear condensate drip shield on the underside is standard on the braising pan. A fully enclosed torsion bar-type counter-balance provides easy operation to open the cover to maintain it open at any position. The cover opens to the back. It is hinged to the frame, so it moves independently from the pan body.

The following sizes and options are available:

Model	PAN DIMENSIONS			Tilt
	Left to Right	Front to Rear	Depth	
BPM-15EC/EA/ECT2	18-1/8" (460mm)	28-1/4" (718mm)	8" (203mm)	Manual
BPM-30EC/EA/ECT2	26-1/4" (667mm)	28-1/4" (718mm)	10" (254mm)	Manual
BPP-30EC/EA/ECT2	26-1/4" (667mm)	28-1/4" (718mm)	10" (254mm)	Power
BPM-40EC/EA/ECT2	35-3/4" (908mm)	28-1/4" (718mm)	10" (254mm)	Manual
BPP-40EC/EA/ECT2	35-3/4" (908mm)	28-1/4" (718mm)	10" (254mm)	Power



Information contained in this document is known to be current and accurate at the time of printing/creation. Unified Brands recommends referencing our product line websites, unifiedbrands.net, for the most updated product information and specifications. © 2019 Unified Brands. All Rights Reserved. Unified Brands is a wholly-owned subsidiary of Dover Corporation.

IMPORTANT - READ FIRST - IMPORTANT

- CAUTION:** BE SURE OPERATORS READ, UNDERSTAND AND FOLLOW THE OPERATING INSTRUCTIONS, CAUTIONS, AND SAFETY INSTRUCTIONS IN THIS MANUAL.
- WARNING:** THIS UNIT IS INTENDED FOR USE IN THE COMMERCIAL HEATING, COOKING AND HOLDING OF WATER AND FOOD PRODUCTS, PER THE INSTRUCTIONS CONTAINED IN THIS MANUAL. ANY OTHER USE COULD RESULT IN SERIOUS PERSONAL INJURY OR DAMAGE TO EQUIPMENT AND WILL VOID WARRANTY.
- WARNING:** ELECTRICALLY GROUND THE PAN AT THE TERMINAL PROVIDED. FAILURE TO GROUND UNIT COULD RESULT IN ELECTROCUTION AND DEATH.
- WARNING:** THE BRAISING PAN MUST BE INSTALLED BY PERSONNEL WHO ARE QUALIFIED TO WORK WITH ELECTRICITY. IMPROPER INSTALLATION COULD RESULT IN PERSONAL INJURY OR EQUIPMENT DAMAGE.
- CAUTION:** STAND AWAY FROM HOT WATER OR FOOD PRODUCTS WHILE TILTING THE PAN DIRECT CONTACT COULD RESULT IN SEVERE BURNS.
- WARNING:** WHEN TILTING BRAISING PAN FOR PRODUCT TRANSFER:
- 1) WEAR PROTECTIVE OVEN MITT AND PROTECTIVE APRON.
 - 2) USE CONTAINER DEEP ENOUGH TO CONTAIN AND MINIMIZE SPLASHING.
 - 3) PLACE CONTAINER ON STABLE, FLAT SURFACE, AS CLOSE TO PAN AS POSSIBLE.
 - 4) STAND TO SIDE OF PAN WHILE POURING — NOT DIRECTLY IN POUR PATH OF HOT CONTENTS.
 - 5) RETURN PAN BODY TO LEVEL POSITION AFTER CONTAINER IS FILLED OR TRANSFER IS COMPLETE.
 - 6) DO NOT OVER FILL CONTAINER. AVOID DIRECT SKIN CONTACT WITH HOT CONTAINER AND ITS CONTENTS.
- WARNING:** DO NOT HEAT AN EMPTY PAN FOR MORE THAN FIVE MINUTES AT A SETTING HIGHER THAN 300°F.
- WARNING:** AVOID ALL DIRECT CONTACT WITH HOT EQUIPMENT SURFACES. DIRECT SKIN CONTACT COULD RESULT IN SEVERE BURNS.

- WARNING:** AVOID ALL DIRECT CONTACT WITH HOT FOOD OR WATER IN THE BRAISING PAN. DIRECT CONTACT COULD RESULT IN SEVERE BURNS.
- WARNING:** IF THE PAN CONTAINS ITEMS IN SAUCE OR MELTED FAT, THEY COULD SLIDE FORWARD SUDDENLY DURING TILTING AND CAUSE HOT LIQUID TO SPLASH OUT.
- WARNING:** USE OF ANY REPLACEMENT PARTS OTHER THAN THOSE SUPPLIED BY THE MANUFACTURER OR ITS AUTHORIZED DISTRIBUTORS Voids ALL WARRANTIES AND MAY CAUSE BODILY INJURY OR EQUIPMENT DAMAGE. SERVICE PERFORMED BY OTHER THAN FACTORY AUTHORIZED PERSONNEL WILL VOID ALL WARRANTIES.
- WARNING:** TURN OFF ELECTRIC POWER BEFORE WORKING ON INTERNAL COMPONENTS.
- WARNING:** BEFORE ANY CLEANING OPERATION, TURN THE THERMOSTAT TO "OFF" TO CUT OFF POWER TO THE HEATING ELEMENTS. BEFORE CLEANING ANY PART OTHER THAN THE INSIDE OF THE PAN, DISCONNECT THE ELECTRICAL SUPPLY AT THE CIRCUIT BREAKER OR FUSE BOX.
- WARNING:** BE CAREFUL TO AVOID CONTACT WITH CLEANING PRODUCTS IN ACCORDANCE WITH SUPPLIER AND MANUFACTURER RECOMMENDATIONS. MANY CLEANERS ARE HARMFUL TO THE SKIN, EYES, MUCOUS MEMBRANES AND CLOTHING. READ THE WARNINGS AND FOLLOW DIRECTIONS ON THE CLEANER LABEL.
- CAUTION:** NEVER LEAVE A CHLORINE SANITIZER IN CONTACT WITH STAINLESS STEEL FOR LONGER THAN 30 MINUTES. LONGER CONTACT CAN CAUSE CORROSION.
- WARNING:** DO NOT USE ANY FUSE WITH A HIGHER AMP RATING THAN THE RATING SPECIFIED FOR THAT CIRCUIT.
- WARNING:** KEEP WATER AND SOLUTIONS OUT OF CONTROLS AND ELECTRICAL EQUIPMENT. NEVER USE A HIGH PRESSURE HOSE TO CLEAN THE BRAISING PAN.
- WARNING:** BEFORE REPLACING ANY PARTS, DISCONNECT THE UNIT FROM THE ELECTRIC POWER SUPPLY.
- IMPORTANT:** SERVICE PERFORMED BY OTHER THAN FACTORY AUTHORIZED PERSONNEL WILL VOID WARRANTIES.

Options/accessories available with these models are:

1. Fill faucet with swing spout, left or right mounted - specify single or double pantry
2. Fill faucet with 48" or 60" spray hose assembly, left or right mounted - specify single or double pantry
3. Caster mounting kit
4. Flanged Feet
5. 2" Tangent draw-off (Factory-installed must be indicated on initial order)
6. Steamer Insert set
7. Steamer pan carrier
8. Pouring lip strainer
9. Strainer for 2" TDO valve



2" Tangent Draw-Off

INSPECTION & UNPACKING

- CAUTION:** SHIPPING STRAPS ARE UNDER TENSION AND CAN SNAP BACK WHEN CUT.
- CAUTION:** UNIT WEIGHS 420 TO 560 LB (190 TO 255KG). FOR SAFE HANDLING, INSTALLER SHOULD OBTAIN HELP AS NEEDED, OR EMPLOY APPROPRIATE MATERIALS HANDLING EQUIPMENT (SUCH AS A FORKLIFT, DOLLY, OR PALLET JACK) TO REMOVE THE UNIT FROM THE SKID AND MOVE IT TO THE PLACE OF INSTALLATION.

The unit will arrive completely assembled, wrapped in protective plastic on a heavy skid, in a heavy wooden crate. Immediately upon receipt, inspect the crate for damage. Report any apparent shipping damage or an incorrect shipment to the delivery agent.

When installation is to begin, get someone to assist in removing the crate. Lift it straight up and away from the unit. Write down the model number, serial number, and installation date of your unit, and keep this information for future reference. Space for these entries is provided at the top of the Service Log in this manual.

Cut the straps holding the unit on the skid, and lift the unit straight up off the skid. The unit ships strapped to a skid and crated. (Shown is a 40-gallon model with optional 2" tangent draw-off)



INSTALLATION

WARNING: THE UNIT MUST BE INSTALLED BY PERSONNEL WHO ARE QUALIFIED TO WORK WITH ELECTRICITY AND PLUMBING. IMPROPER INSTALLATION CAN CAUSE INJURY TO PERSONNEL AND/OR DAMAGE TO THE EQUIPMENT. THE UNIT MUST BE INSTALLED IN ACCORDANCE WITH APPLICABLE CODES. THE UNIT MUST BE INSTALLED BY A LICENSED PLUMBER WHEN INSTALLED WITHIN THE COMMONWEALTH OF MASSACHUSETTS.

WARNING: ELECTRICALLY GROUND THE UNIT AT THE TERMINAL PROVIDED. FAILURE TO GROUND UNIT COULD RESULT IN ELECTROCUTION AND DEATH. BEFORE ANY ELECTRICAL CONVERSION, VERIFY THAT THE BRANCH CIRCUIT WIRING IS ADEQUATE TO HANDLE ANY INCREASE IN AMPERAGE REQUIREMENTS. REFER TO THE ELECTRICAL SPECIFICATIONS LISTED BELOW.

Internal wiring for the Braising Pan is supplied complete. When you receive the unit, it is ready for connection. A wiring diagram is located inside the control box on the right side of the pan, as well as in this manual.

Your pan was performance-tested at the factory to confirm that all controls and heating elements were functioning correctly.



Electrical Connection

Installation is as follows:

1. Set the unit in place and level it by turning the adjustable feet. Crank the pan body to a completely horizontal position. Check levelness by placing a spirit level on the bottom of the pan. The unit must be level to avoid uneven cooking across the pan.
2. Make a waterproof connection with the incoming power line at the electrical service entrance at the bottom of the connection box at rear of control console. A BX connection is NOT recommended. ELECTRICALLY GROUND THE UNIT at the proper terminal.
3. Provide the proper electrical supply as specified on the electrical information plate. Comply with local codes and the National Electrical Code ANSI/NFPA 7- latest edition.
4. Use only copper wire, rated at least 75°C and of proper gage. See chart below.
5. Standard equipment is shipped ready for 208V, 240V, or 480V, 3-phase operation. Refer to the wiring diagram located on the inside cover of the control box and the instructions below for conversion to single-phase operation.

A jumper wire and “conversion” label are included with the unit. They can be found in a plastic bag attached to the trunnion assembly inside the control box.

6. For conversion from 3-phase to 1-phase
 - a. Verify that the branch circuit wiring is adequate for any increased amperage requirements. (See table on above)
 - b. 1-phase requires two jumper wires. One jumper wire exists on the terminal block for 3- phase input. The second jumper wire is located in a plastic bag inside the control box.
 - c. Attach jumper wires to terminal block as per wiring diagram for 1 phase supply.
 - d. Complete “conversion label” (supplied in bag) and adhere it to the control box near the UL data plate.
7. Core probe storage bracket (C2T models only)
 - a. It is recommend that the core probe storage bracket be installed on the control console. It is not recommend that the core probe storage bracket be installed on the pan or cover.
 - b. To obtain proper adhesion, the bonding surface must be unified, clean and dry. Clean the bonding surface with rubbing alcohol and allow the surface to dry. Next firmly apply pressure to the storage bracket to help improve bond strength. After application, the bond strength will increase as the adhesive flows onto the surface. At room temperature, approximately 50% of the ultimate strength will be achieved after 20 minutes, 90% after 24 hours and 100% after 72 hours.

ELECTRICAL REQUIREMENTS

Use only copper wire rated for 75°C or higher; Gauge recommendations (AWG) are for 25’ runs from the breaker box (if longer runs are required, increase wire size accordingly).

Model	SINGLE PHASE				
	KW	208V		240V	
		Amps	Wire (AWG)	Amps	Wire (AWG)
BPM-15EC/EA/ECT2	7.6	37	8	32	8
BPM-30EC/EA/ECT2	11.5	56	6	48	6
BPP-30EC/EA/ECT2	11.5	56	6	48	6
BPM-40EC/EA/ECT2	15.3	74	4	64	4
BPP-40EC/EA/ECT2	15.3	74	4	64	4

Model	3-PHASE									
	KW	208V		240V		480V		KW	440V	
		Amps	Wire (AWG)	Amps	Wire (AWG)	Amps	Wire (AWG)		Amps	Wire (AWG)
BPM-15EC/EA/ECT2	7.6	21	10	18	10	9	12	7.0	9	12
BPM-30EC/EA/ECT2	11.5	32	8	28	8	14	12	10.5	14	12
BPP-30EC/EA/ECT2	11.5	32	8	28	8	14	12	10.5	14	12
BPM-40EC/EA/ECT2	15.3	43	8	37	8	19	10	14.0	19	10
BPP-40EC/EA/ECT2	15.3	43	8	37	8	19	10	14.0	19	10

INITIAL START-UP

WARNING: WATER IS EXTREMELY HOT AND CAN CAUSE SEVERE BURNS. AVOID CONTACT WITH HOT WATER WHEN EMPTYING UNIT.

CAUTION: ALWAYS RAISE PAN COVER BEFORE TILTING TO AVOID DAMAGING THE HINGE AND COUNTERBALANCE.

Now that your braising pan has been installed, you should test it to ensure that the unit is operating correctly.

1. Remove literature and packing materials from the interior and exterior of the unit.
2. Put enough water into the pan to cover the bottom to a depth of 1/4 to 1/2 inch (6 to 13 mm). With the pan body in the horizontal position, note how the water lies in the pan, to confirm that the pan was leveled properly during installation.
3. Turn on the electrical power to the unit.
4. Set the temperature controller to 235°F (113°C) using instruction on page 10. The heating indicator light should come on to show that the pan is heating. Heating should continue until the water boils.
5. To shut the unit down, turn off the electrical power to the unit.
6. When the water has cooled to a safe temperature, turn the tilting handwheel clockwise to pour out the water and to confirm that the pan body can be tilted smoothly from horizontal to vertical. For power tilt models, push the UP/DOWN switch to confirm operation of tilting system.

If the unit functions as described above, it is ready for use. If it does not, contact your local Authorized Service Agency (Domestic) or Engineer (CE).

OPERATION

CAUTION: DO NOT HEAT AN EMPTY PAN FOR MORE THAN FIVE MINUTES AT A SETTING HIGHER THAN 300°F. DAMAGE TO THE PAN COULD RESULT.

WARNING: KEEP THE AREA AROUND BRAISING PAN FREE AND CLEAR OF COMBUSTIBLE MATERIALS.

CAUTION: KEEP FLOORS IN BRAISING PAN WORK AREA CLEAN AND DRY. IF SPILLS OCCUR, CLEAN IMMEDIATELY TO AVOID THE DANGER OF SLIPS OR FALLS.

CAUTION: REPLACE THE HOLE PLUG BEFORE CLEANING OTHERWISE WATER COULD ENTER THE ELECTRICAL CONTROL BOX AND DAMAGE THE PARTS.



OPERATOR CONTROLS

1. Classic Control (-EC) Models

- Lighted Power ON switch located on the control console. It controls main power to the unit.
- The temperature knob, located on the control console, is used to set the pan temperatures between 175° and 400°F
- Heating indicator light located on the control console, lights when the controller energizes the heating elements and will cycle on and off once the unit reaches set temperature. If the unit is tilted, the heating elements will be disabled and the light will turn off until the unit is returned to the cooking position.
- A handwheel controls the worm and gear mechanism that smoothly tilts the pan body and holds it in the desired position
- For power tilt units a switch is located on the control panel to raise and lower the pan body.

2. Advanced Control (-EA) models

- Lighted Power ON switch located on the control console. It controls main power to the unit.
- Heating indicator light located on the control console, lights when the controller energizes the heating elements and will cycle on and off once the unit reaches set temperature. If the unit is tilted, the heating elements will be disabled and the light will turn off until the unit is returned to the cooking position.
- SET TnnP Mode - Allows power to the controller without the pan heating; the pan will heat once the LOW TEMP, MANUAL or HIGH TEMP button is selected.
- LOW TEMP Button – Used to set operating temperature of the pan at a preset low temperature (default = 175°F). Can be pressed at any point during operation of the unit to change the set temperature to the preset value except when there is an active TIMER enabled.
- MANUAL Mode button – Enables the user modify the desired cooking temperature of the pan (between 175F and 400F) using the temperature knob and display (default = 212F). The operator will press the MANUAL button and set the desired temperature using the temperature knob and display. Once the desired temperature is shown in the display, the user may either press the MANUAL button again or wait 5 seconds and the set temperature will be accepted by the controller and locked in. After the set temperature is accepted, it may be changed at any time by pressing the

MANUAL button and resetting the temperature using the same process above.

- HIGH TEMP button – Used to set operating temperature of the pan at a preset high temperature (default = 400°F). Can be pressed at any time during operation of the unit to change the set temperature to the preset value except when there is an active TIMER enabled.
 - TIMER button - once the appropriate set temperature is selected using the HIGH TEMP, MANUAL or LOW TEMP buttons; a countdown timer can be set to remind the user when the cooking process is completed.
 - Range – 1 minute to 10 hours
 - When the timer expires:
 - The set temperature will automatically change to the LOW TEMP setting and will continue at this setting until the user changes the temperature via MANUAL or HIGH TEMP buttons.
 - An audible alarm will notify the user that attention is required, the alarm will continue to sound until the user presses the TIMER button.
 - An active TIMER can be cancelled by pressing and holding the TIMER button for 5 secs.
 - Set temp can be changed during an active timer by pressing the MANUAL button and adjusting the set temp using the Temperature knob and display.
 - HIGH TEMP and LOW TEMP presets cannot be used to change the setpoint once a TIMER has started.
 - READY alarm – The control will sound 3 beeps when the unit has reached within 20 degrees of set point during pre-heat or when a higher set temperature is selected.
 - A handwheel controls the worm and gear mechanism that smoothly tilts the pan body and holds it in the desired position
 - For power tilt units a switch is located on the control panel to raise and lower the pan body.
- ### 3. Cook2Temp™ Control (-EC2™) Models
- Lighted Power ON switch located on the control console. Controls main power to the unit.
 - Heating indicator light located on the control console, lights when the controller energizes the heating elements and will cycle on and off once the unit reaches set temperature. If the unit is tilted, the heating elements will be disabled and the light will turn off until the unit is returned to the cooking position.
 - Set Mode – Allows power to the controller without the pan heating, the pan will heat once the LOW TEMP, MANUAL or HIGH TEMP button is selected.
 - LOW TEMP Button – Used to set a unit temperature of the pan at a preset low temperature (default = 175°F). Can be pressed at any time during operation of the unit to change the unit temperature to the preset value expect when there is an active TIMER or an active Cook2Temp.
 - MANUAL Button – Enables the user to modify the unit temperature of the pan (between 175°F and 400°F) using the temperature knob and display (default = 212°F). The operator will press the MANUAL button and then select the desired unit temperature using the temperature knob and display. Once the desired unit temperature is shown on the display, the user may either press the MANUAL button again or wait 5 seconds and the selected temperature will be accepted by the controller and locked in. After the selected temperature is accepted it may be changed at any time by pressing the MANUAL button and resetting the temperature using the same process as above except when there is an active AUTO Cook2Temp.
 - HIGH TEMP Button – Used to set unit temperature of the pan at a preset high temperature (default = 400°F). Can be pressed at any time during operation of the unit to change the unit temperature to the preset value expect when there is an active TIMER or an active Cook2Temp.

- g. **TIMER Button** – Once the appropriate unit temperature is selected using the LOW TEMP, MANUAL or HIGH TEMP buttons, a countdown timer can be set to remind the user when the cooking process is completed.
1. Range – 1 minute to 10 hours.
 2. When the timer expires:
 - a. The unit temperature will automatically change to the LOW TEMP setting and will continue at this setting until the user changes the temperature via MANUAL or HIGH TEMP buttons.
 - b. An audible alarm will notify the user that attention is required, the alarm will continue to sound until the user presses the TIMER button.
 3. An active timer can be cancelled by pressing and holding the TIMER button for 5 seconds.
 4. Unit temperature can be changed during an active timer by pressing the MANUAL button and adjusting the unit temperature using the temperature knob and display.
 5. LOW TEMP and HIGH TEMP presets cannot be used to change the unit temperature once a TIMER has been enabled.
 6. AUTO C2T and MANUAL C2T cannot be used once a timer has been enabled. The timer must first be cancelled and then AUTO C2T or MANUAL C2T can be enabled.
- h. **Ready alarm** – The control will sound 3 beeps when the unit has reached within 20 degrees of set point during pre-heat and when a higher unit temperature is selected.
- i. **AUTO C2T Button** – Enables the user to select a set product temperature (between 100°F and 230°F) using the temperature knob and display. The operator will press the AUTO C2T button and then select the set product temperature using the temperature knob and display. Once the set product temperature is shown on the display, the user may either press the AUTO C2T button again or wait 5 seconds and the selected temperature will be accepted by the controller and locked in. The unit temperature is automatically set 100°F above the set product temperature and cannot be changed at any time during an active AUTO C2T. After the set product temperature is accepted it may be changed at any time by first cancelling AUTO C2T and then using the same process as above to reset the temperature.
1. After the set product temperature is accepted by the controller and locked in. The unit will begin to heat and the display will scroll the actual product temperature followed by the set product temperature. This display will continue until the cook process has completed.
 2. An active AUTO C2T can be cancelled by pressing and holding the AUTO C2T button for 5 seconds and the unit will then return to Set Mode.
 3. LOW TEMP, MANUAL or HIGH TEMP presets cannot be used to change the unit temperature once there is an active AUTO C2T. The unit temperature is automatically set by the controller.
 4. Once the set product temperature has been reached and held for 20 seconds consecutively the unit will automatically enable Hold Mode.
- j. **MANUAL C2T Button** – Enables the user to select a set product temperature (between 100°F and 230°F) using the temperature knob and display. The operator will press the MANUAL C2T button and then select the set product temperature using the temperature knob and display. Once the set product temperature is shown on the display, the user may either press the MANUAL C2T button again or wait 5 seconds and the selected temperature will be accepted by the controller and locked in. Once the set product temperature has been accepted the user will be prompted to select a unit temperature via the MANUAL button. Once the set unit temperature is shown on the display, the user may either press the MANUAL C2T button again or wait 5 seconds and the selected temperature will be accepted by the controller and locked in. After the set product temperature and unit temperature are accepted, the set product temperature may be changed at any time by first cancelling MANUAL C2T and then using the same process as above to reset the temperature.
1. After the set product temperature and unit temperature are accepted by the controller and locked in. The unit will begin to heat and the display will scroll the actual product temperature followed by the set product temperature. This display will continue until the cook process has completed.
 2. An active MANUAL C2T can be cancelled by pressing and holding the MANUAL C2T button for 5 seconds and the unit will then return to Set Mode.
 3. Unit temperature can be changed during an active MANUAL C2T by pressing the MANUAL button and adjusting the unit temperature using the temperature knob and display.
 4. Once the set product temperature has been reached and held for 20 seconds consecutively the unit will automatically enable Hold Mode.
- k. **Hold Mode** – Allows the unit to be controlled by the set product temperature and core probe.
1. Hold Mode is automatically enabled once a set product temperature has been reached and held for 20 seconds consecutively.
 2. The display will scroll the actual product temperature followed by the hold timer.
 3. If the set product temperature falls below 142°F.
 - a. An audible alarm along with the display flashing the actual product temperature will notify the user that attention is required.
 - b. The alarm can be silenced by pressing any button.
 - c. The Alarm will resound every 10 minutes until the product temperature returns above 142°F.
 4. If the actual product temperature rises 10°F above the set product temperature.
 - a. An audible alarm along with the display flashing the actual product temperature will notify the user that attention is required.
 - b. The alarm can be silenced pressing any button.
 - c. The alarm will resound every 10 minutes until the actual product temperature returns to within 10°F of the set product temperature.
 5. At initial hold timer completion (default = 4 hours).
 - a. An audible alarm will be given for 5 seconds.
 - b. The alarm can be silenced by pressing any button.
 - c. The alarm will continue to resound every 15 minutes until Hold Mode is exited.
- l. **Display Descriptions**
1. SET nndE – Allows power to the controller without the pan heating, the pan will heat once the LOW TEMP, MANUAL or HIGH TEMP button is selected.
 2. SET PrOd tEnP – Indicates the desired finished product temperature.
 3. SEt Unit tEnP – Indicates the desired unit temperature.
 4. SEt POInt – Indicates the set point for the desired finished product temperature.
 5. ACT – Indicates the actual product temperature.
 6. CPER – Indicates a core probe error and will continue to display until the error has been resolved.
 7. Prob – Indicates a unit probe error and will continue to display until the error has been resolved.
 8. End – Indicates the cooking process has completed.
 9. End HOLd – Indicates the initial hold timer has completed.

4. Cook2Temp™ Control (-EC2T™) Core Probe

- a. Ensure the core probe has been properly cleaned and sanitized before each use.
- b. It is important that the tip of the core probe be placed correctly into the product since only the tip of the core probe senses the product temperature. Do this by inserting the core probe halfway into the product, positioning the tip at the center of the food mass, avoiding any bones. If placing into a semi-liquid or liquid product, occasionally stirring the product will ensure an accurate core probe reading. Do not let the core probe tip touch the edges, bottom or side of the unit.
- c. If the core probe is not plugged into the receptacle when either the AUTO C2T or MANUAL C2T button is pressed then an audible alarm along with a core probe error message will notify the user that attention is required. Simply plug the core probe into the receptacle and continue with the input process.
- d. If the core probe is unplugged from the receptacle during the cooking process or while in Hold Mode an audible alarm along with a core probe error message will notify the user that attention is required. Simply plug the core probe back into the receptacle and the cook process or Hold Mode will continue.
- e. While the core probe is not in use ensure the sealing cap is properly protecting the panel mount connector. Failure to properly use the sealing cap could result in damage to the unit.

OPERATING PROCEDURE

WARNING: WHEN TILTING BRAISING PAN FOR PRODUCT TRANSFER:

- 1) USE CONTAINERS DEEP ENOUGH TO CONTAIN AND MINIMIZE PRODUCT SPLASHING.
- 2) PLACE CONTAINER ON A STABLE, FLAT SURFACE, AS CLOSE TO THE BRAISING PAN AS POSSIBLE.
- 3) STAND TO THE SIDE OF THE PAN WHILE POURING — NOT DIRECTLY IN THE POUR PATH OF HOT CONTENTS.
- 4) RETURN PAN BODY TO UPRIGHT POSITION AFTER CONTAINER IS FILLED OR TRANSFER IS COMPLETE.
- 5) DO NOT OVERFILL CONTAINER. AVOID DIRECT SKIN CONTACT WITH HOT CONTAINER AND CONTENTS.

CAUTION: DO NOT HEAT AN EMPTY PAN FOR MORE THAN FIVE MINUTES AT A SETTING HIGHER THAN 300°F. DAMAGE TO THE PAN COULD RESULT.

WARNING: STEAM CAN CAUSE BURNS. AVOID ESCAPING STEAM WHEN RAISING COVER.

WARNING: ITEMS IN SAUCE OR MELTED FAT CAN SLIDE FORWARD SUDDENLY DURING TILTING AND SPLASH THE HOT LIQUID.

WARNING: KEEP THE AREA AROUND BRAISING PAN FREE AND CLEAR OF COMBUSTIBLE MATERIALS.

CAUTION: KEEP FLOORS IN BRAISING PAN WORK AREA CLEAN AND DRY. IF SPILLS OCCUR, CLEAN IMMEDIATELY TO AVOID THE DANGER OF SLIPS OR FALLS.

CAUTION: REPLACE THE HOLE PLUG BEFORE CLEANING OTHERWISE WATER COULD ENTER THE ELECTRICAL CONTROL BOX AND DAMAGE THE PARTS.

CAUTION: DO NOT OVERFILL THE BRAISING PAN WHEN COOKING, HOLDING OR CLEANING. KEEP LIQUIDS AT LEAST 2-3" (5-8 CM) BELOW THE PAN BODY RIM TO ALLOW CLEARANCE FOR STIRRING, BOILING PRODUCT AND SAFE TRANSFER.



Tilting pan body



1. To Tilt Pan Body

- a. Manual Tilt Model -
Turn the tilting handwheel clockwise to tilt the pan body, or counterclockwise to return the pan body to horizontal. 23 complete turns of the handwheel will tilt the body 90 degrees to vertical.
- b. Power Tilt Model -
 1. Press the power tilt switch marked “up” to raise the pan or “down” to lower the pan.
 2. The spring loaded switch will return to the OFF (middle) position when you release it.
 3. If the power tilt mechanism stops working (see the Troubleshooting section) and you must raise or lower the pan body without delay, you can tilt the body by hand. Remove the small plug on top of the control box and fit the provided tool into the hole. Turn the tool clockwise to lower it. It may take several minutes to move the pan to the desired position, but the operation can be speeded up by substituting a reversible drill with a 1/4” hexagonal driver bit in place of the tool.

2. Cooking

- a. To simmer or slowly heat an item, set the temperature at 210°F (99°C) or lower. Put the cover down to minimize moisture loss, or leave it up to help dry or reduce the product. Set the control higher to cook or drive off moisture faster. You may adjust the control to any setting to cook the item exactly as required.
- b. Standing to one side of the pan (to avoid the steam that will be released) grasp the nearer corner of the cover handle and raise the cover. The cover will stay in the open position until you push it down.
- c. To pour product, remove grease, or assist in cleaning, first raise the cover, then tilt the pan forward by turning the tilting handwheel. When you stop turning the wheel, the pan body will hold its position.
- d. To return the pan to the horizontal position, turn the wheel counterclockwise.
- e. To turn the pan off, turn the power switch to the “OFF” position.

NOTICE: It is recommended that an instant-read thermometer be used to check the internal temperature throughout the cooking process and after the cooking process has been completed to ensure the food has been cooked sufficiently.

3. Routine Clean-Up

After each use, turn the control and power switch to “OFF” and clean all food contact surfaces to ensure proper sanitation. At the end of the day, or at least once every 24 hours, turn off the heat and shut off electric power to the unit and clean both the interior and exterior of the pan. See Page 7 for more detailed cleaning instructions.

SEQUENCE OF OPERATION

The following “action-reaction” outline is provided to help you understand how the braising pan actually functions.

When you turn the main power switch to “ON” and set the temperature, the contactors close and power flow to the heating elements and indicator light.

When the pan temperature reaches the value set on the dial, the relay switch opens and causes the contactors to open. This stops the flow of power to the heating elements and the indicator light. As soon as the controller senses that the pan is cooling below the set temperature, the relay closes, the contactors close, and the heaters and indicator light come on again.

This on and off cycle continues, maintaining the pan at the set temperature. This is why the indicator light on and off cycling is seen during normal operation. If the pan temperature exceeds 400°F (204°C) for any reason, a high-limit thermostat shuts off the power until the pan cools. At that point, the thermostat automatically resets to permit normal operation to start again.

Turning the main power "OFF" shuts down all control and heating circuits.

The heating is controlled by alternating between feeding full power and completely cutting power off. The pan heats as fast as it can until it reaches the set temperature, no matter what that temperature is. Turning the dial to a higher setting will cause heating to continue longer, until the pan reaches a higher temperature, but it cannot make the pan heat any faster.

Manual tilt models, turning the hand wheel rotates a shaft, which turns a gear wheel on one of the trunnions supporting the pan body. Turning the gear produces the tilting action.

Power tilt models, pushing the up/down switch operates a gear motor which turns shaft and gear wheel as described above.

For all braising pans, the power to the heaters is cut off when the pan is tilted past a slight inclination of 10° degrees. It is acceptable to cook with the pan tilted forward at a small angle (about 5 - 7 degrees) to let liquids collect to front of pan or allow them to drain out of the draw off valve.

CLEANING

WARNING: KEEP WATER AND SOLUTIONS OUT OF CONTROLS AND ELECTRICAL EQUIPMENT. DO NOT USE A HIGH PRESSURE HOSE TO CLEAN THE CONTROL CONSOLE, ELECTRICAL CONNECTIONS, ETC.

CAUTION: MOST CLEANERS ARE HARMFUL TO THE SKIN, EYES, MUCOUS MEMBRANES AND CLOTHING. PRECAUTIONS SHOULD BE TAKEN TO WEAR RUBBER GLOVES, GOGGLES OR FACE SHIELD AND PROTECTIVE CLOTHING. CAREFULLY READ THE WARNINGS AND FOLLOW THE DIRECTIONS ON THE LABEL OF THE CLEANER TO BE USED.

WARNING: BEFORE ANY CLEANING OPERATION, TURN THERMOSTAT DIAL TO "OFF" TO CUT ANY POWER TO THE HEATING ELEMENTS. BEFORE CLEANING ANY PART OTHER THAN THE INSIDE OF THE PAN, DISCONNECT ELECTRICAL SUPPLY AT CIRCUIT BREAKER OR FUSE BOX.

CAUTION: NEVER LEAVE A CHLORINE SANITIZER IN CONTACT WITH STAINLESS STEEL SURFACES FOR LONGER THAN 30 MINUTES. LONGER CONTACT CAN CAUSE CORROSION.

CAUTION: KEEP CAUSTIC COMPOUNDS SUCH AS FRYER BOILOUT CLEANERS AWAY FROM ALUMINUM PARTS OF THE LID HINGE SYSTEM AND THE COUNTERBALANCE ASSEMBLY. HIGHLY CAUSTIC COMPOUNDS COULD DAMAGE THIS MATERIAL.



Use a brush, sponge, cloth, plastic or rubber scraper, or plastic wool to clean.

Don't use metal implements or steel wool.

BRAISING PAN

1. Suggested Tools

- A good stainless steel cleaner
- Brushes in good condition
- Cloth for cleaning controls
- Chlorine sanitizer
- Heavy Duty Cleaner (if required)

2. Procedure

- Clean all food-contact surfaces soon after use. It is best to clean the pan before it has completely cooled. If the unit is in continuous use, completely clean and sanitize both the inside and outside at least once every 12 hours.
- To remove any large amount of food left in the pan, tilt the pan all the way up and flush it with lukewarm water. Do not damage the surface of the pan by scraping it with a metal tool. Scratches make the surface more difficult to clean, and provide ideal breeding places for bacteria.

- Following the supplier's directions, make up a warm solution of the cleaner. Carefully wash the inside and outside of the pan body with the cleaning solution.
- Use a cloth moistened with cleaning solution to clean controls, the control console, and electric conduit.
- Rinse the pan very well with lukewarm water, and drain it completely.
- As part of the daily cleaning program, clean all inside and outside surfaces that may have been soiled. Remember to check such parts as the undersides of the cover, the electrical console and other more remote spots. Clean between the pan body and the consoles using a brush.
- Controls and the control console may be cleaned with a damp cloth or sprayed with a garden hose spray connected to city water supply. Do not use a pressure sprayer directly on the unit or electrical parts.
- To remove materials stuck to the equipment, use a brush, sponge, cloth, plastic or rubber scraper, or plastic wool with the cleaning solution. To make washing easier, let the cleaning solution sit in the unit and soak into the residue, or heat the solution briefly. Do not use any gritty cleaner or metal tool that might scratch the surface. Scratches make the surface harder to clean, and also provide places for bacteria to grow. Do not use steel wool. Small bit of steel wool left in the surface of the unit can cause rusting and pitting.
- The outside of the unit may be polished with a recognized stainless steel cleaner such as Zepper from the Zep Manufacturing Company.
- When the equipment needs to be sanitized, use a sanitizing solution equivalent to one that supplies 100 parts per million available chlorine. Get advice about the best sanitizing agent from your supplier of sanitizing products.
- Following supplier instructions, apply the sanitizing agent after the unit has been cleaned and drained. Thoroughly drain off the sanitizer.
- After the unit has been cleaned, sanitized and drained, let all surfaces air dry unless the unit must be used again right away.
- It is recommended that the unit be sanitized just before use. Follow the directions of the sanitizer supplier.
- About once a week (more often if the water is very hard), use a heavy duty cleaner to remove any mineral deposits or film left by hard water or foods. Follow the supplier's directions very carefully, and rinse the unit off thoroughly, as soon as cleaning is finished.
- If especially difficult cleaning problems persist, contact your cleaning product supplier for help. The supplier has a trained technical staff with laboratory facilities to serve you.

CLEANING CORE PROBE

Remove all food soil from core probe by wiping entire core probe and cable assembly with warm detergent solution and a clean cloth. Remove detergent solution by wiping core probe and cable assembly with clean rinse water and a cloth. Allow core probe and cable assembly to air dry. Do not immerse core probe. Hand wash only and immediately let air dry.

MAINTENANCE

WARNING: ELECTRIC POWER ALWAYS SHOULD BE SHUT OFF BEFORE WORK IS DONE ON INTERNAL COMPONENTS.

WARNING: DISCONNECT ELECTRICAL POWER FROM THE UNIT BEFORE ATTEMPTING TO GREASE THE TRUNNION BEARINGS.



Your braising pan is designed to require minimum maintenance, but certain parts may need replacement after prolonged use. After installation, no user adjustment should be necessary. If a service need arises, only authorized personnel should

perform the work.

Service personnel should check the unit at least once a year. This periodic maintenance should include inspecting electrical wires and connections, cleaning the inside of the control console, and possible adjustment of the pilot light. (Units with standing pilot ignition only) At least twice a year, grease the two trunnion bearings and worm gear.

We recommend the use of number two grade LGI lithium grease. Add grease through the zerk fittings on the gear hosing until grease flows out of the bearings around trunnion shaft. Also, add grease in the gear to cover arc that is in contact with the worm gear. Clean up excess grease.

A Service Log is provided with the warranty information at the back of this manual. Each time service is performed on your equipment, enter the date on which the work was done, what was done, and who did it. Keep the manual with the equipment for quick and easy reference.

REPLACEMENT PARTS

To order parts, contact your Authorized Service Agent. Supply the model designation, serial number, part description, part number, quantity, and when applicable, voltage and phase.

CONTACT US

If you have questions pertaining to the content in this manual, contact Unified Brands at 888-994-7636.

TROUBLESHOOTING

This unit is designed to operate smoothly and efficiently if properly maintained. However, the following is a list of checks to make in the event of a problem. Wiring diagrams are found at the end of this manual. When in doubt, turn unit off and call for service at 888-994-7636. If an item on the check list is marked with (X), it means that the work should be done by a Authorized Service Agent.

WARNING: ELECTRICAL POWER MUST BE SHUT OFF BEFORE WORK IS DONE ON INTERNAL COMPONENTS. USE OF ANY REPLACEMENT PARTS OTHER THAN THOSE SUPPLIED BY THE MANUFACTURER OR THEIR AUTHORIZED DISTRIBUTOR CAN CAUSE INJURY TO THE OPERATOR AND DAMAGE TO THE EQUIPMENT AND WILL VOID ALL WARRANTIES. SERVICE PERFORMED BY OTHER THAN FACTORY-AUTHORIZED PERSONNEL WILL VOID ALL WARRANTIES.

SYMPTOM	WHO	WHAT TO CHECK (X indicates work that should only be performed by a qualified service representative)
Display not lit (Advanced and C2T only)	User	a. That power supply is on.
	Authorized Service Rep Only	b. Fuses, accessible by removing caps on the side of the control box. c. For loose or broken wires or damaged RTD probe. X d. Temperature controller functioning, by listening for a click when the switch opens or closes and verifying LEDs on back of board. X e. Contactor functioning. X
PROB in display (Advanced and C2T only)	Authorized Service Rep Only	a. For loose or broken wires or damaged/failed RTD probe. X b. PCB board malfunction/failure
HI in display (Advanced and C2T only)	Authorized Service Rep Only	a. For loose or broken wires or damaged/failed RTD probe. X b. PCB board malfunction/failure
Pan will not heat, but indicator light comes on	Authorized Service Rep Only	a. Heating elements for short circuit. X

Pan will not heat, and indicator light will not light (STD and Classic)	User	a. That power supply is on.
	Authorized Service Rep Only	b. Fuses, accessible by removing caps on the side of the control box. c. For loose or broken wires or damaged RTD probe. X d. Temperature controller functioning, by listening for a click when the switch opens or closes and verifying LEDs on back of Classic board. X e. Contactor functioning. X
Pan continues to heat after it reaches desired temperature	User	a. Temperature controller dial setting. Turn down if too high.
	Authorized Service Rep Only	b. Temperature controller functioning. X c. Temperature Controller calibration and offsets. X d. Contactor, to determine if it is de-energized. X
Pan does not reach desired temperature	User	a. Temperature Controller dial setting. Turn up if too low.
	Authorized Service Rep Only	b. Heating elements for ground short or open (burned out) element. X c. Temperature controller functioning, by listening for a click when the switch opens or closes. X d. Temperature Controller calibration and offsets. X e. Contactor functioning. X
Rapid clicking noise (chattering)	User	a. For low voltage.
	Authorized Service Rep Only	b. Contactor for dirt or corrosion on the contacts. X
Uneven cooking due to "hot spots"	User	a. That the pan body is level.
Uneven cooking due to "cold spots"	Authorized Service Rep Only	a. For open (burned out) heating element. X
Pan is hard to tilt (Manual Tilt Models)	Authorized Service Rep Only	a. Gears for foreign materials, lubrication and alignment. X
Pan will not tilt (Power Tilt Models)	User	a. That electrical power supply is on. b. or overheated actuator motor. Wait 15 minutes for motor to cool, then operate the power tilt.
	Authorized Service Rep Only	c. For blown fuse on motor control circuit - Replace fuse with approved equal. X d. For damaged DC rectifier and operating relays. X e. Correct setting of upper and lower limit switches. X
C2T in display (C2T only)	User	a. That core probe is plugged into the receptacle.
	Authorized Service Rep Only	b. For loose or broken wires or damaged/failed RTD probe. X c. PCB board malfunction/failure. X

STAND & FOOT ASSEMBLY

CALL FACTORY FOR REPLACEMENT PARTS:
888-994-7636

Parts List

Key	Description	Part #
1	CASTER KIT (SET OF 2 WITH BRAKE AND 2 W/O BRAKE)	146354
1	CASTER WITH BRAKE (W/O FOOT ADAPTER)	146513
1	CASTER WITHOUT BRAKE (W/O FOOT ADAPTER) NOT SHOWN	146515
2	FOOT ADAPTER	146516
3	FLANGED FOOT (W/O FOOT ADAPTER)	146521
4	BULLET FOOT (W/O FOOT ADAPTER)	146628
5	FRICTION RING	146520



COVER & COUNTERBALANCE ASSEMBLIES

CALL FACTORY FOR REPLACEMENT PARTS:
888-994-7636

Parts List

Key	Qty	Description	Part #
1	1	COVER & COUNTERBALANCE ASSEMBLY, 15 GALLON	162232 162235
1	1	COVER & COUNTERBALANCE ASSEMBLY, 30 GALLON	144812 145480
1	1	COVER & COUNTERBALANCE ASSEMBLY, 40 GALLON	144453 144790
3	4	STUD WELD, 1/4"-20 X 1-1/4"	012589
4	4	WASHER, LOCK 3/8"	005618
5	4	SCREW, HEX HEAD CAP 3/8"-16 X 1"	005612
6	4	NUT, HEX 3/8"-16	005619
7	4	DOME NUTS, 1/4-20	090567
8	2	SCREW, TRUSS HEAD, #10-32 X 3/8"	004173

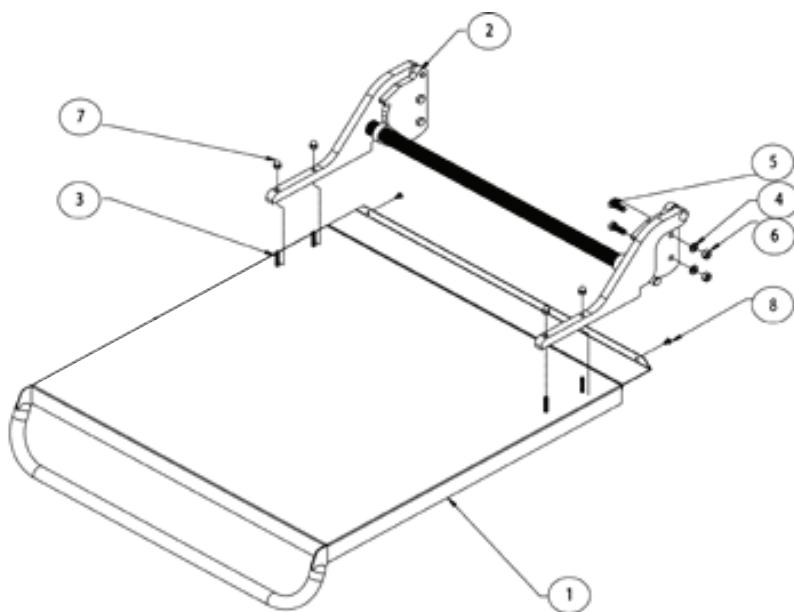

For Classic (-EC) Models

CALL FACTORY FOR REPLACEMENT PARTS:
888-994-7636

Parts List

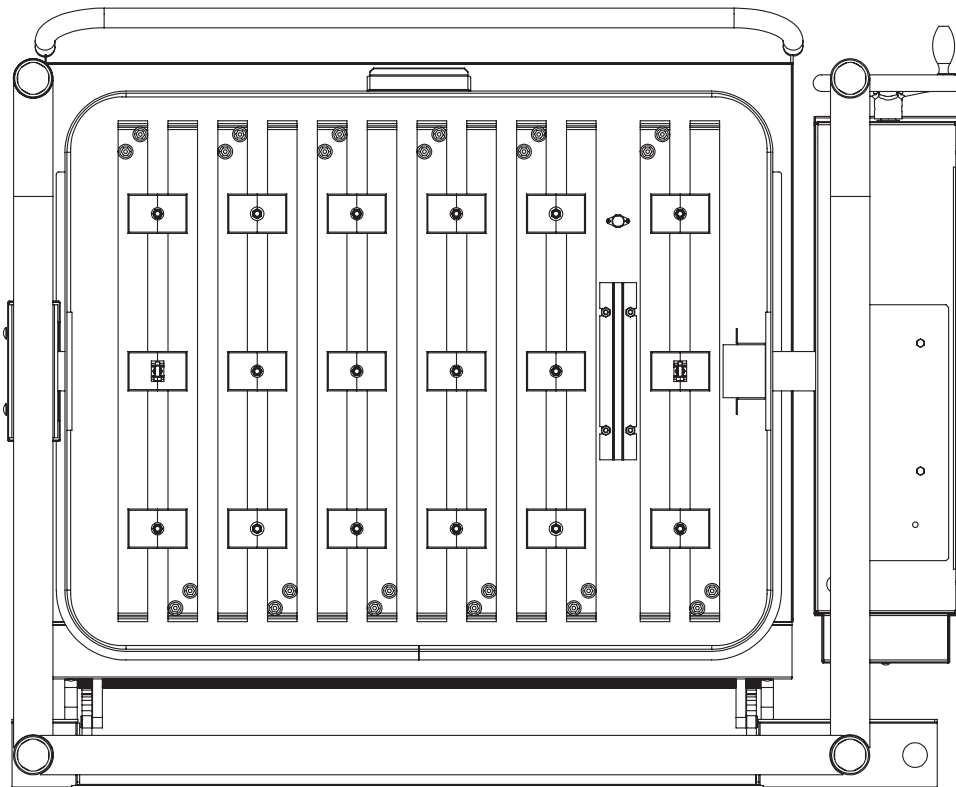
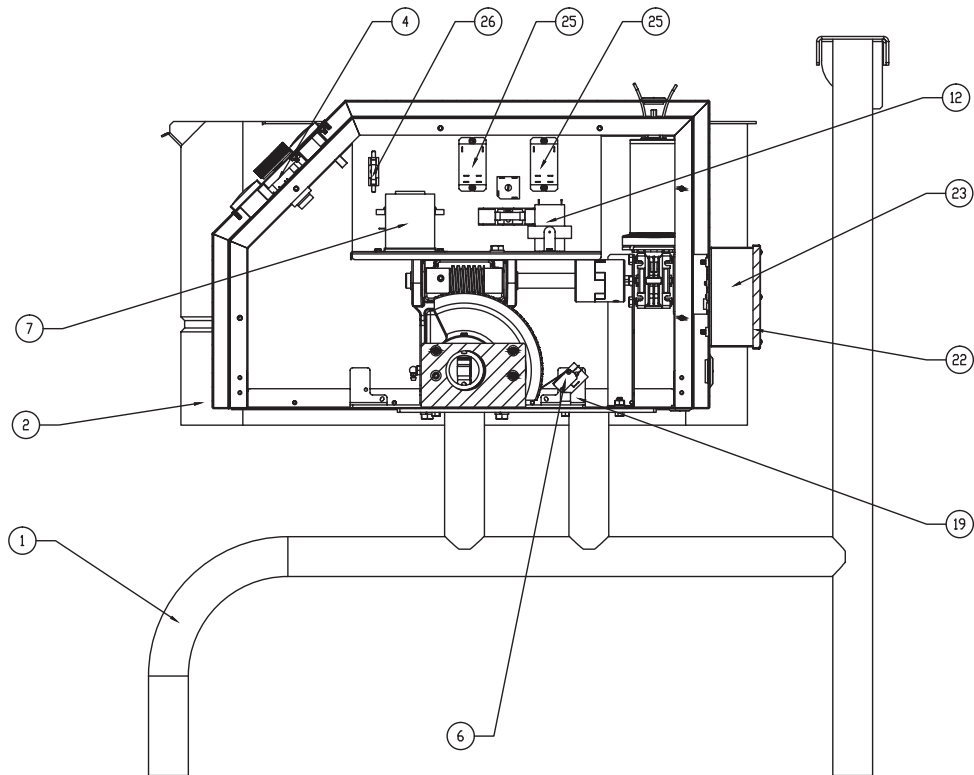

For Advanced (-EA) &
Cook2Temp™ (-EC2T™) Models
CALL FACTORY FOR REPLACEMENT PARTS:
888-994-7636

Parts List

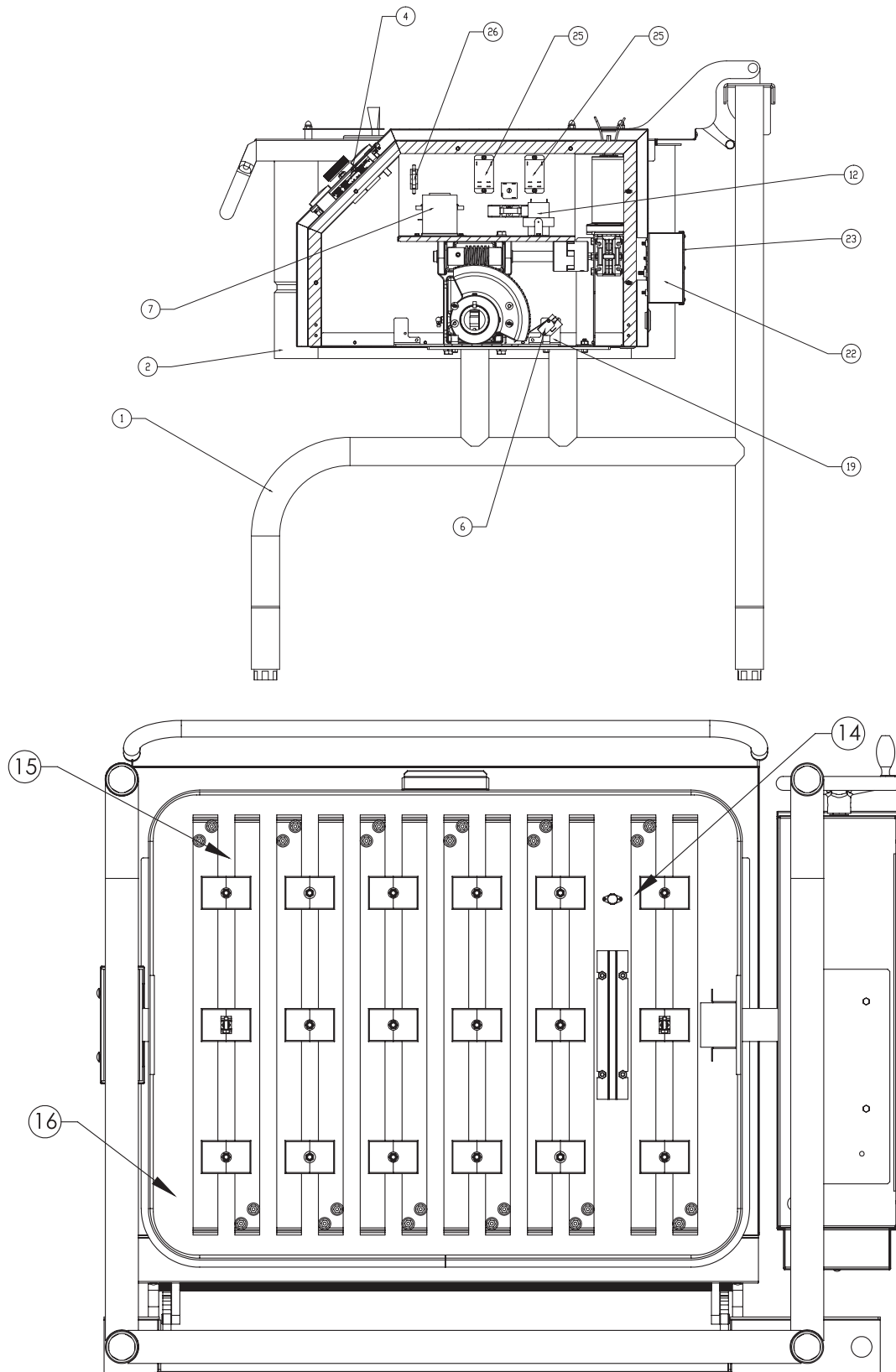

**For Classic (-EC), Advanced (-EA) &
Cook2Temp™ (-EC2T™) Models**

**CALL FACTORY FOR REPLACEMENT PARTS:
888-994-7636**

Parts List

To order parts, contact your Authorized Service Agent. Supply the model designation, serial number, part description, part number, quantity, and when applicable, voltage and phase.

KEY	DESCRIPTION	PART NO.
1	STAND ASSEMBLY - 15 GAL	155725
1	STAND ASSEMBLY - 30 GAL	144848
1	STAND ASSEMBLY - 40 GAL	144332
2	PAN WELDMENT - 15 GAL	162573
2	PAN WELDMENT - 30 GAL	145654
2	PAN WELDMENT - 40 GAL	144789
4a	TEMP CONTROL - EC	174842
4b	TEMP CONTROL - EA	174836
4c	TEMP CONTROL -C2T	176897
5	LIGHT, AMBER	116384
6	TILT SWITCH	143319
7	CONTACTOR	148102
8	GROUND TERMINAL	119829
9	TERMINAL BLOCK	003888
10	FUSE HOLDER	077854
11	FUSE, 3 AMP	077853
12	TRANSFORMER - 208/240V	137441
12	TRANSFORMER - 480V	137694
13	POWER SWITCH	176921
14	HIGH LIMIT THERMOSTAT	142755
15	ELEMENT - 208V	145656
15	ELEMENT - 240V	146185
15	ELEMENT - 480V	149114
16	COVER ELEMENT HOUSING - 15 GAL	162575
16	COVER ELEMENT HOUSING - 30 GAL	146186
16	COVER ELEMENT HOUSING - 40 GAL	144343
17	RIGHT SIDE COVER (HIDDEN)	175146
18	LEFT TRUNNION COVER ASSEMBLY	144776
19	TILT SWITCH BRACKET ASSEMBLY	145689
20	CONTROL BOX ASSEMBLY	175153
22	TERMINAL BLOCK BOX	175042
23	TERMINAL BLOCK BOX COVER	175043
24a	KNOB ALUMINUM - EC	175095
24b	KNOB ALUMINUM -EA, -EC2T	174829

KEY	DESCRIPTION	PART NO.
25	RELAY-24V	119814
26	FUSE, 3AMP 3AG	2077853
x	FERRITE BEAD	175836
x	TRUNION SEAL	175017
x	RETAINING RING	175164
x	O-RING	138359
x	EXTERNAL RET. RING	138356
x	COLLAR, SHAFT SEAL	138354
x	SHAFT SEAL 1.00"	136088
x	TRANSFORMER, POWER TILT 480V	051469
x	OVERLAY, MANUAL TILT, CLASSIC	175044
x	OVERLAY, POWER TILT, CLASSIC	175045
x	OVERLAY, MANUAL TILT, ADVANCED	175048
x	OVERLAY, POWER TILT, ADVANCED	175205
x	OVERLAY, MANUAL TILT, COOK2TEMP	176894
x	OVERLAY, POWER TILT, COOK2TEMP	176893
x	PROBE, BPM-15, C2T	176649
x	PROBE, BPM/BPP-30 & 40, C2T	176650
x	BRACKET, PROBE, BRAISING PAN, C2T	176653
x	BRACKET ASSEMBLY, PROBE STORAGE	177091
x	SOCKET, PANEL MOUNT ASSY, CORE PROBE, C2T	176925
x	CAP, SOCKET, PANEL MOUNT, CORE PROBE, C2T	176927
x	WIRE HARNESS, CONTROL, CORE PROBE, C2T	176920
x	HARNESS, CONTROL	175258
x	HARNESS, POWER 208/240V	148539
x	HARNESS, POWER 480V	149291
x	HARNESS, ELEMENTS 208/240V - 15 GAL	157600
x	HARNESS, ELEMENTS 480V - 15 GAL	157607
x	HARNESS, ELEMENTS 208/240V - 30 GAL	148560
x	HARNESS, ELEMENTS 480V - 30 GAL	149293
x	HARNESS, ELEMENTS 208/240V - 40 GAL	148561
x	HARNESS, ELEMENTS 480V - 40 GAL	149292

x- Item not depicted/called out in drawing or photograph

MANUAL TILT ASSEMBLY

CALL FACTORY FOR REPLACEMENT PARTS:
888-994-7636

Parts List

Key	Qty	Description	Part #
1	1	GEAR CARRIER	002624
2	1	SHAFT, HANDWHEEL	144834
3	1	GEAR, WORM	128001
4	1	GEAR SECTOR	009829
5	1	KEY GIB	012031
6	1	HANDWHEEL	139152
7	2	PIN ROLL	012614
8	2	SCREW SET SOCKET	012060
9	2	BEARING ROLLER	002790
10	2	BEARING SLEEVE	137239
11	1	PLUG PIPE	010286
14	1	FITTING GREASE 90 (NOT SHOWN)	012195
15	1	BUSHING SNAP (NOT SHOWN)	000453
16	2	WASHER LOCK	005618
17	2	SCREW HEX HEAD CAP	005612

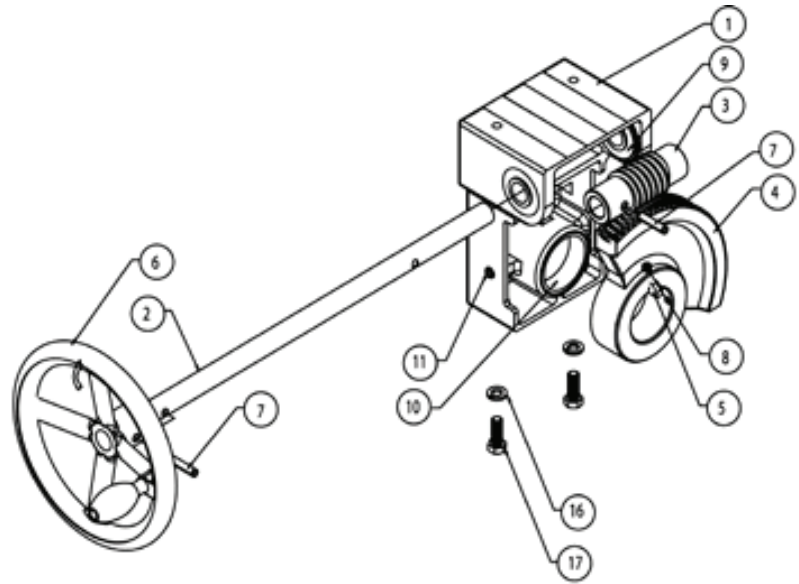

POWER TILT ASSEMBLY

CALL FACTORY FOR REPLACEMENT PARTS:
888-994-7636

Parts List

Key	Qty	Description	Part #
1	1	ELECTRIC TILT SHAFT	144791
2	1	POWER LIFT MOTOR [204/240 VOC]	144794
3	1	SHAFT COUPLING	144615
4	1	GEAR CARRIER ASSY	137880
4a	1	CARRIER GEAR	002624
4b	2	BEARING ROLLER	002790
4c	2	BEARING SLEEVE	137239
4d	1	PLUG PIPE	010286
4e	1	FITTING GREASE 90	012195
5	1	GEAR, WORM	128001
6	1	GEAR SECTOR	009829
6a	2	SCREW SET SOCKET	012060
7	1	KEY GIB	012031
8	1	PIN ROLL	012614
9	1	MOTOR BRACKET	146114
10	1	REAR MOTOR BRACKET	146117
11a	1	FUSE HOLDER [MOTOR]	077840
11b	1	FUSE	144856
11c	1	RECTIFIER	145660
11d	2	RELAY [24VAC, DPST, NO]-2 REQ'D	119814
12	5	NUT HEX HEAD 1/4"-20	005601
13	5	WASHER LOCK 1/4"	005655
14	3	SCREW HEX HEAD CAP 1/4"-20 X 2-1/2" LONG	052584
15	2	SCREW HEX HEAD CAP	005609
16	2	WASHER LOCK 3/8"	005618
17	2	SCREW HEX HEAD CAP 3/8"-16 X 1" LONG	005612
18	1	ELECTRIC TILT SHAFT KEY	013386
x	1	HOLE PLUG-1"	146369
x	1	MANUAL OVERRIDE CRANK	145659
x	1	POWER TILT SWITCH, RECESSED ROCKER NO INDICATOR	144857
x	2	TILT LIMIT SWITCH (POWER TILT UP/DN)	002982
x	1	WIRE HARNESS,LOW VOLTAGE	146197
x	1	WIRE HARNESS-HIGH VOLTAGE	148769

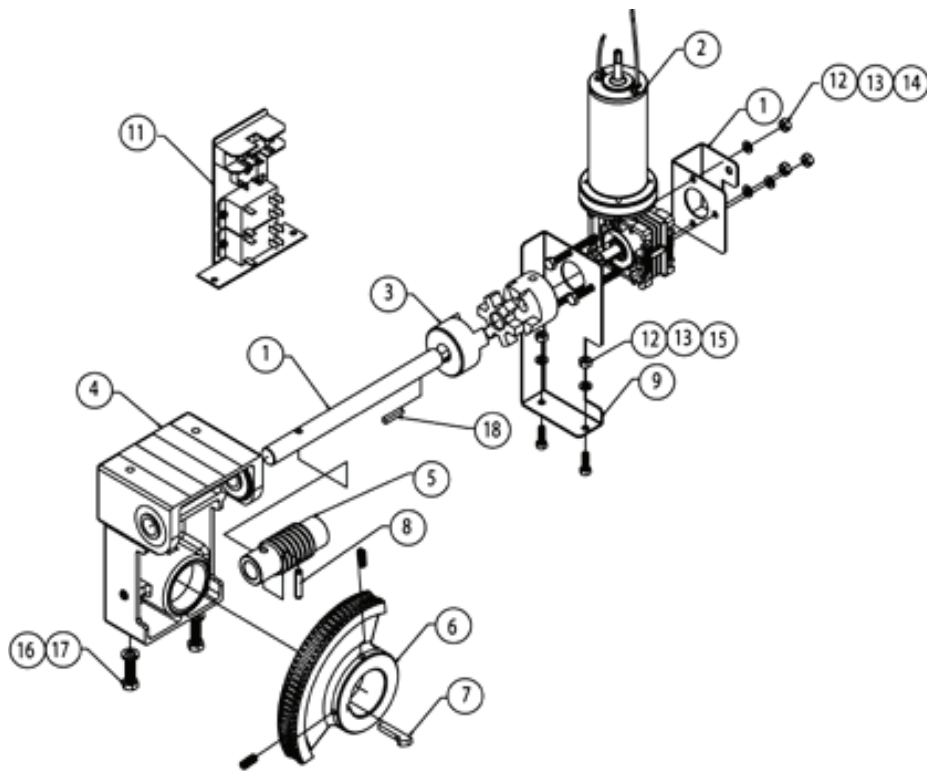

Classic (-EC)
MANUAL TILT

CALL FACTORY FOR REPLACEMENT PARTS:
888-994-7636

Wiring Diagram

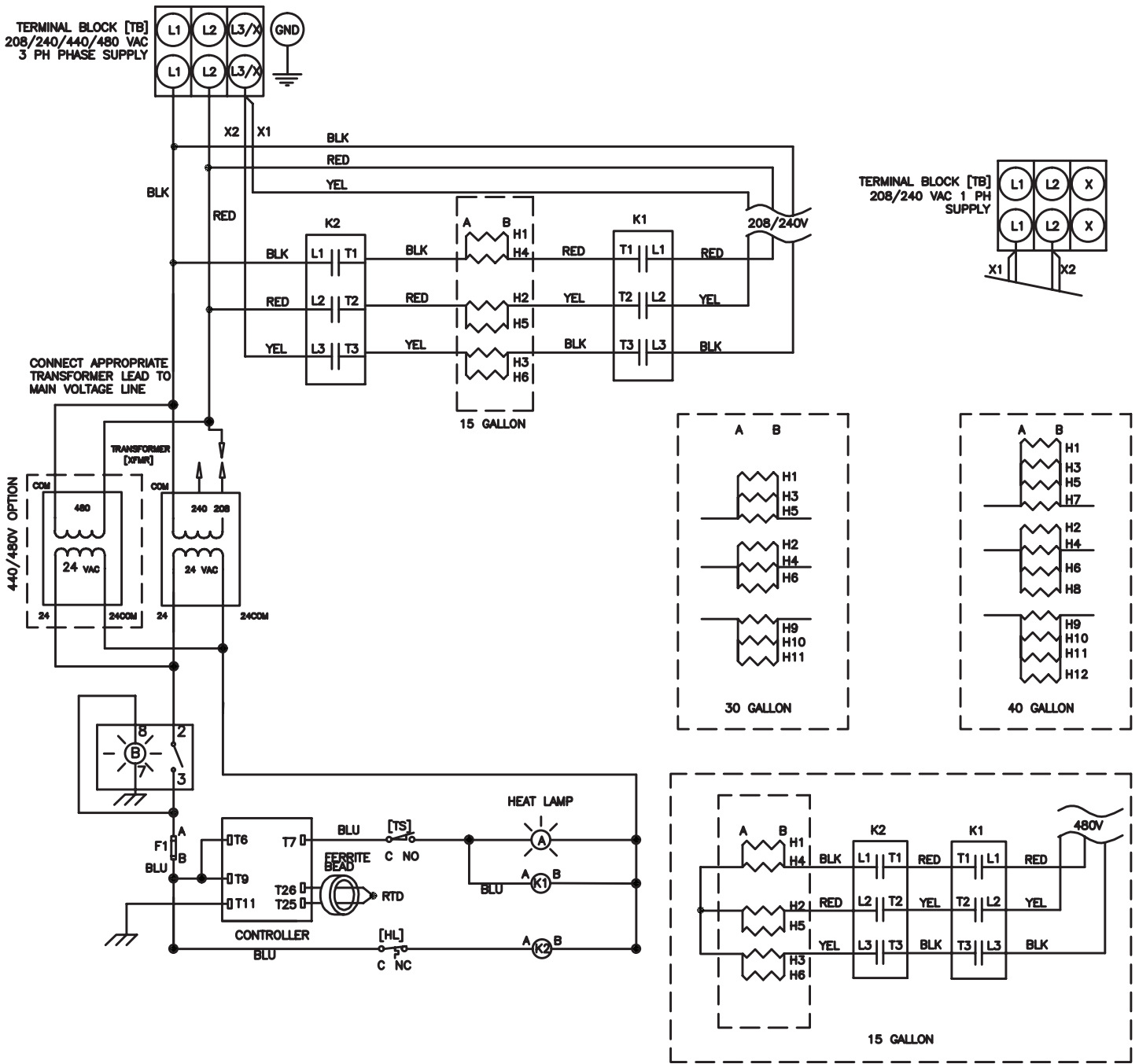

P/N 174705 REV B

Classic (-EC)
POWER TILT

CALL FACTORY FOR REPLACEMENT PARTS:
888-994-7636

Wiring Diagram

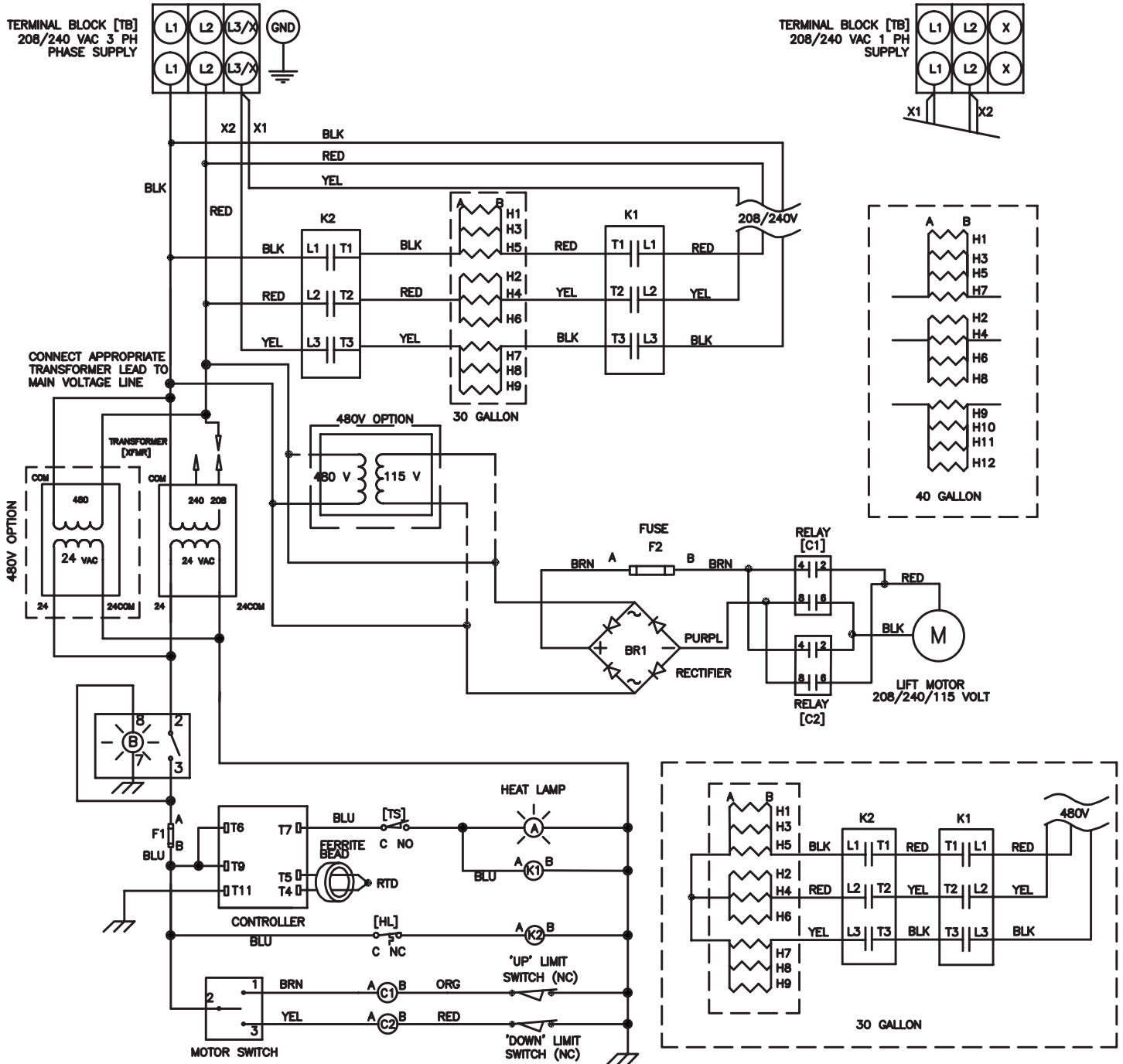

P/N 174707 REV D

Wiring Diagram

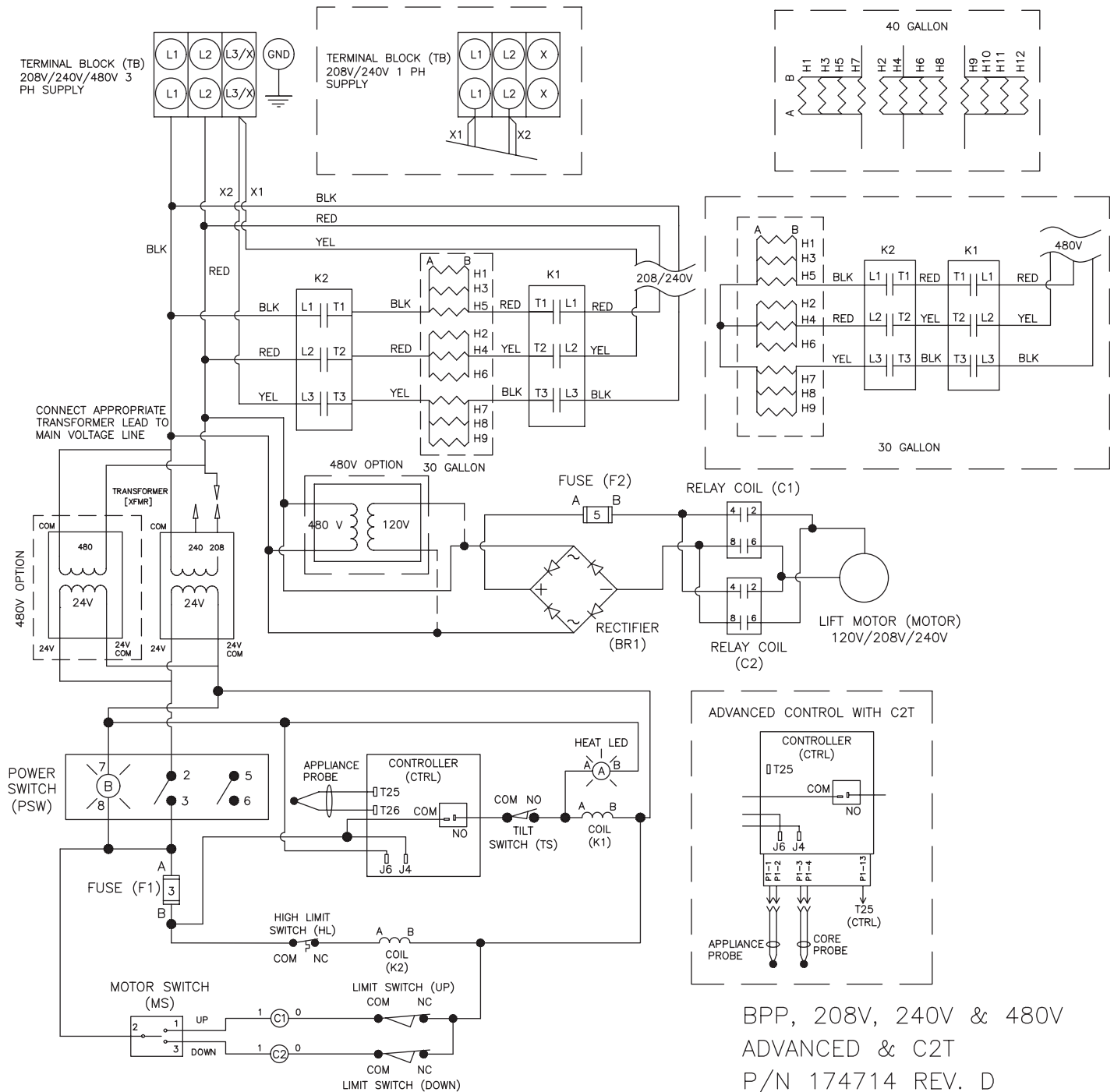

BPP, 208V, 240V & 480V
ADVANCED & C2T
P/N 174714 REV. D

