

# **Lang**<sup>®</sup>

## **THERMOSTATIC DROP-IN ELECTRIC GRIDDLE**

136TDI, 148TDI, 160TDI

### **Installation and Operation Instructions**

2M-W356 Rev. D 1/27/12

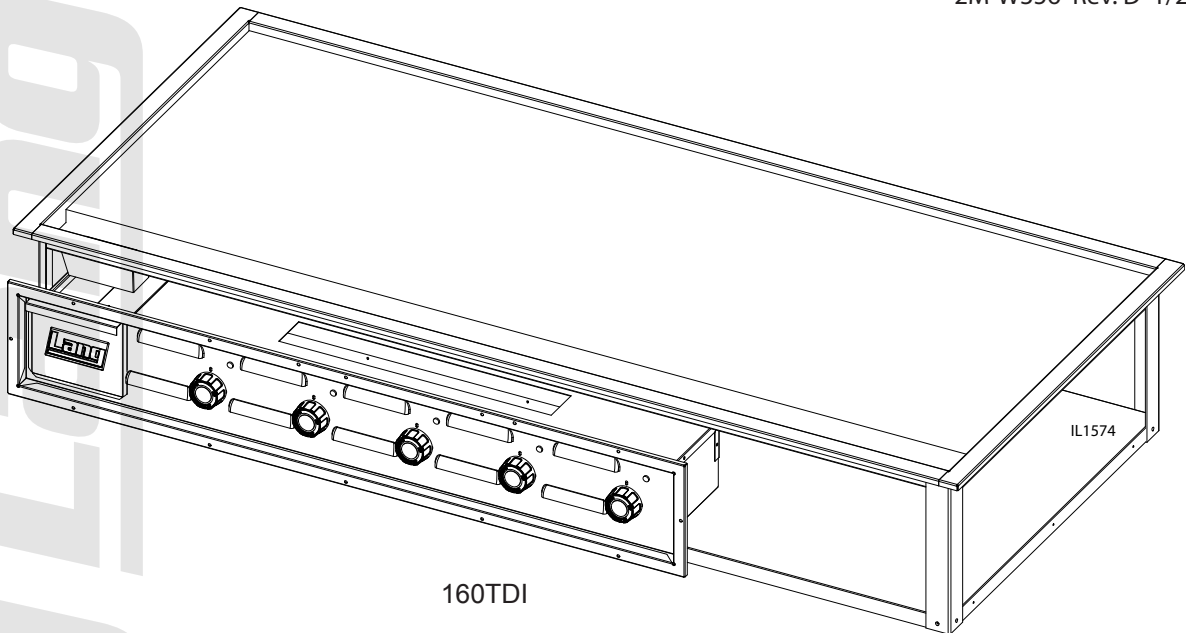

160TDI



## SAFETY SYMBOL



These symbols are intended to alert the user to the presence of important operating and maintenance instructions in the manual accompanying the appliance.

### FOR YOUR SAFETY

**DO NOT STORE OR USE GASOLINE OR OTHER FLAMMABLE VAPORS AND LIQUIDS IN THE VICINTIY OF THIS OR ANY OTHER APPLIANCE.**

### POST IN PROMINENT LOCATION

**INSTRUCTIONS TO BE FOLLOWED IN THE EVENT USER SMELLS GAS. THIS INFORMATION SHALL BE OBTAINED BY CONSULTING YOUR LOCAL GAS SUPPLIER. AS A MINIMUM, TURN OFF THE GAS AND CALL YOUR GAS COMPANY AND YOUR AUTHORIZED SERVICE AGENT. EVACUATE ALL PERSONNEL FROM THE AREA.**

### WARNING

**IMPROPER INSTALLATION, ADJUSTMENT, ALTERATION, SERVICE OR MAINTENANCE CAN CAUSE PROPERTY DAMAGE, INJURY OR DEATH. READ THE INSTALLATION, OPERATION & MAINTENANCE INSTRUCTIONS THOROUGHLY BEFORE INSTALLING OR SERVICING THIS EQUIPMENT.**



**WARNING  
RISK OF FIRE OR ELECTRIC SHOCK  
DO NOT OPEN**



**WARNING, TO REDUCE THE RISK OF ELECTRICAL SHOCK, DO NOT REMOVE CONTROL PANEL. NO USER-SERVICABLE PARTS INSIDE. REPAIRS SHOULD BE DONE BY AUTHORIZED SERVICE PERSONNEL ONLY.**

### NOTICE

Using any part other than genuine Lang factory supplied parts relieves the manufacturer of all liability.

Lang reserves the right to change specifications and product design without notice. Such revisions do not entitle the buyer to corresponding changes, improvements, additions or replacements for previously purchased equipment.

Due to periodic changes in designs, methods, procedures, policies and regulations, the specifications contained in this sheet are subject to change without notice. While Lang exercises good faith efforts to provide information that is accurate, we are not responsible for errors or omissions in information provided or conclusions reached as a result of using the specifications. By using the information provided, the user assumes all risks in connection with such use.

## MAINTENANCE AND REPAIRS

Contact your local dealer for service or required maintenance. Please record the model number, serial number, voltage and purchase & Installation Information in the area below and have it ready when you call to ensure a faster service.

Model No.: \_\_\_\_\_

Purchased From: \_\_\_\_\_

Serial No.: \_\_\_\_\_

Location: \_\_\_\_\_

Voltage: \_\_\_\_\_

Purchase Date: \_\_\_\_\_

1-Phase or 3 Phase: \_\_\_\_\_

Installed Date: \_\_\_\_\_



## **PROBLEMS, QUESTIONS or CONCERNS**

Before you proceed consult you authorized Lang service agent directory  
or  
Call the Lang Technical Service & Parts Department at 314-678-6315.

### **TABLE OF CONTENTS**

Specifications . . . . .	4
Equipment Description . . . . .	5
Unpacking . . . . .	6
Installation	
Prepare the Cabinet . . . . .	7
Install Griddle into the Cabinet . . . . .	8
Electrical Connection . . . . .	8
Initial Start-Up	
Pre-Power On . . . . .	9
Power On . . . . .	9
Seasoning Cooking Surface. . . . .	9
Operation	
General . . . . .	10
Operations. . . . .	10
Suggested Times and Temperatures . . . . .	10
Maintenance	
Cleaning . . . . .	11
Carbon Cleaning . . . . .	11
Troubleshooting	
Symptoms / Possible Causes . . . . .	12
Possible Causes / Test . . . . .	13
Wiring Diagram	
208/240VAC . . . . .	14
480VAC . . . . .	15
Exploded View & Parts List . . . . .	16 - 18

#### **NOTICE**

**Service on this or any other Lang appliance must be performed by qualified personnel only. Consult your Lang Authorized Service Agent Directory. You can call our toll free number 314-678-6315 or visit our web site [www.langworld.com](http://www.langworld.com) for the service agent nearest you.**

# EQUIPMENT SPECIFICATIONS

Model	Top-Rough Opening		Controls-Opening		Clearance from combustible surface	Weight		Freight Class
	Width	Depth	Height	Width		Actual	Shipping	
136TDI	36.8"	26.8"	6.5"	30.8"	Sides: 2", Back: 2"	263 lbs.	410 lbs.	85
	933mm	679mm	165mm	781mm		120 kg	186 kg	
148TDI	48.8"	26.8"	6.5"	37.3"		368 lbs.	525 lbs.	
	1238mm	679mm	165mm	946mm		167 kg	239 kg	
160TDI	60.8"	26.8"	6.5"	43.8"		589 lbs.	665 lbs.	
	1543mm	679mm	165mm	1111mm		268 kg	302 kg	

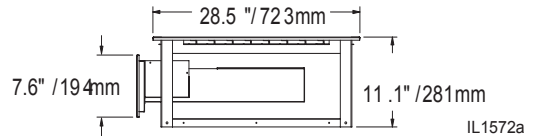
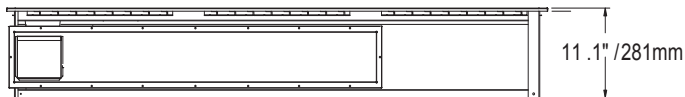
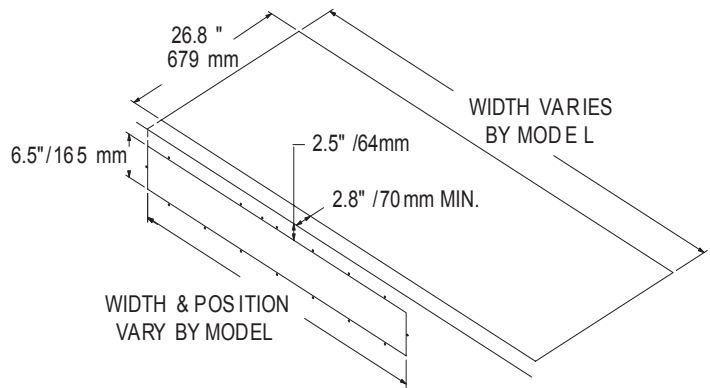
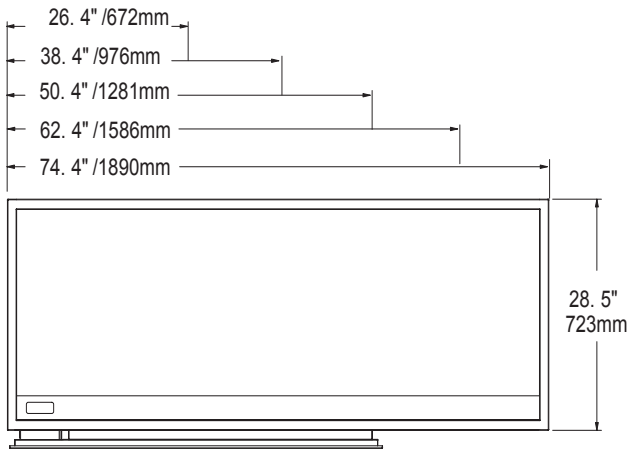

# ELECTRICAL SPECIFICATIONS

MODEL	VOLTS AC	Hz.	PH	KW TOT.	A 1PH.	SPLY	L1	L2	L3	SPLY	KW TOT.	A. 1PH.	SPLY	L1	L2	L3	SPLY
136TDI	208/240	60	1/3	18	87	2	50	50	50	6							
136TDI-480V	480	60	3	18			22	22	22	12							
136TDIC-480V	480	60	3	18			22	22	22	12							
148TDI	208/240	60	1/3	24	116	1	75	75	50	3							
148TDI-480V	480	60	3	24			33	33	22	8							
160TDI	208/240	60	1/3	1	58	2	50	29	29	6	18	87	2	50	50	50	6
160TDI-480V	480	60	3	12			22	13	13	12	18			22	22	22	12

## EQUIPMENT DESCRIPTION

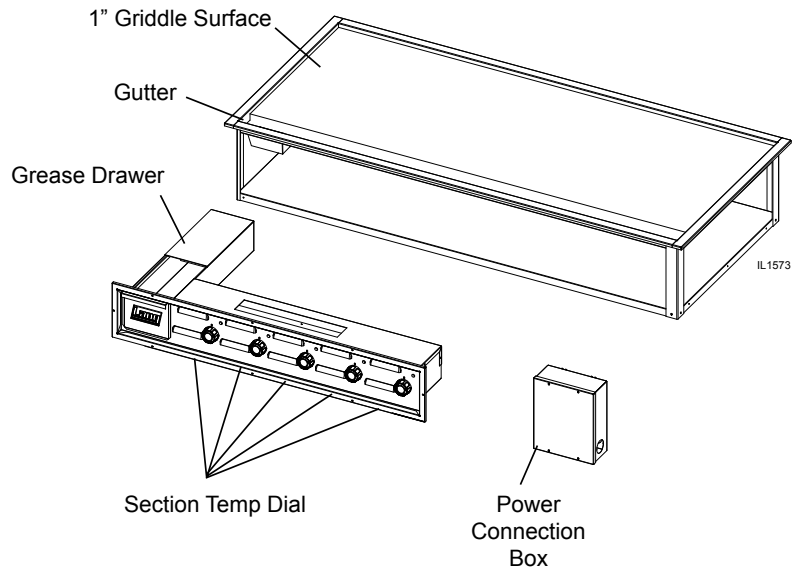

### Electric Drop-In Griddle

The griddle dimensions are 26" (66cm) Deep, 5 3/8" (13.65cm) High, and width is dependent on model number.

The griddle surface is constructed of 1" thick highly polished steel to ensure even heat throughout the griddle. This reduces hot and cold spots and improves recovery time.

### Controls

Each twelve-inch section has its own easy to use solid-state temperature controls with a temperature range from 175°F (79°C) to 450°F (232°C) in 25° increments.

Each twelve-inch section has a set of 6 kW elements for high efficiency, quick recovery and outstanding performance.

**NOTICE** The data plate is on the right side of the griddle. The oven voltage, wattage, serial number, wire size, and clearance specifications are on the data plate. This information should be carefully read and understood before proceeding with the installation.

## UNPACKING

### Receiving the Griddle

Upon receipt, check for freight damage, both visible and concealed. Visible damage should be noted on the freight bill at the time of delivery and signed by the carrier's agent. Concealed loss or damage means loss or damage, which does not become apparent until the merchandise has been unpacked.

If concealed loss or damage is discovered upon unpacking, make a written request for inspection by the carrier's agent within 15 days of delivery. All packing material should be kept for inspection. Do not return damaged merchandise to Star Manufacturing International. File your claim with the carrier.

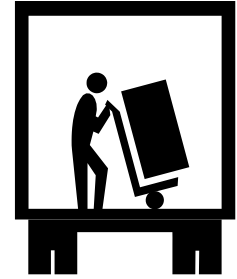

### Location

Prior to un-crating, move the griddle as near its intended location as practical. The crating will help protect the unit from the physical damage normally associated with moving it through hallways and doorways.

### Un-crating

The griddle will arrive completely assembled inside a wood frame covered by a cardboard box and strapped to a skid.

Remove the cardboard cover, cut the straps and remove the wood frame.



**THE UNIT IS EXTREMELY HEAVY. FOR SAFE HANDLING, INSTALLER SHOULD OBTAIN HELP AS NEEDED, OR EMPLOY APPROPRIATE MATERIALS HANDLING EQUIPMENT (SUCH AS A FORKLIFT, DOLLY, OR PALLET JACK) TO REMOVE THE UNIT FROM THE SKID AND MOVE IT TO THE PLACE OF INSTALLATION.**

**ANY STAND, COUNTER OR OTHER DEVICE ON WHICH OVEN WILL BE LOCATED MUST BE DESIGNED TO SUPPORT THE WEIGHT OF THE GRIDDLE.**

**SHIPPING STRAPS ARE UNDER TENSION AND CAN SNAP BACK WHEN CUT.**

# INSTALLATION

## Prepare the Cabinet

Cabinet base must have cross air ventilation. It does not matter if it is on the ends or sides. If vents are not installed, the controls may overheat rendering the griddle useless. For best results, provide a knockout for the control panel a minimum of 4½" - from the griddle support surface as on the following pages.

### Cabinet Cut-out

**136SDI / TDI**

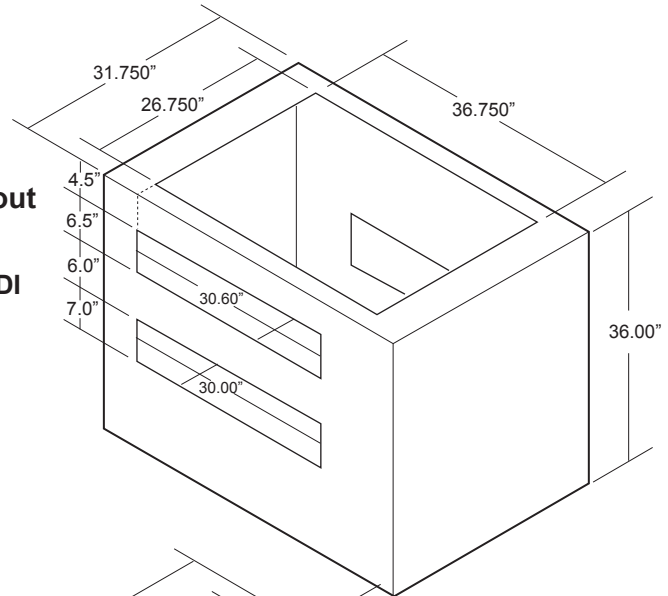

**148SDI / TDI**

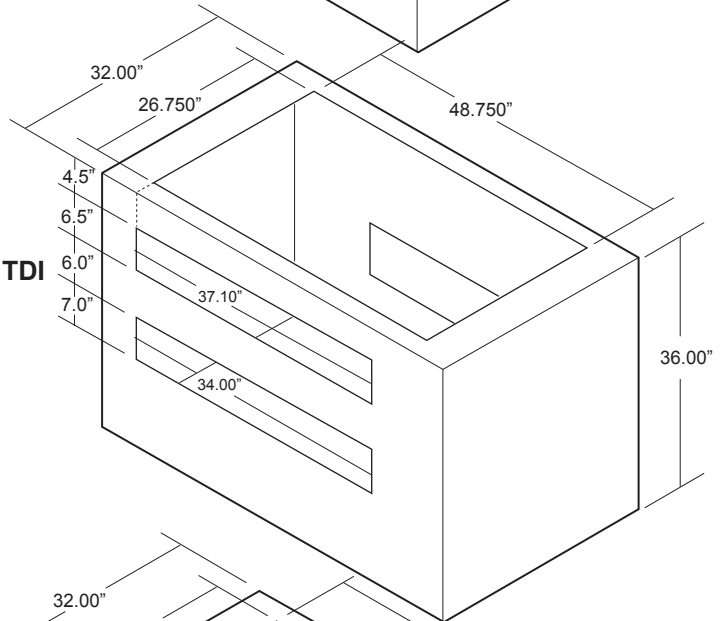

**160SDI / TDI**

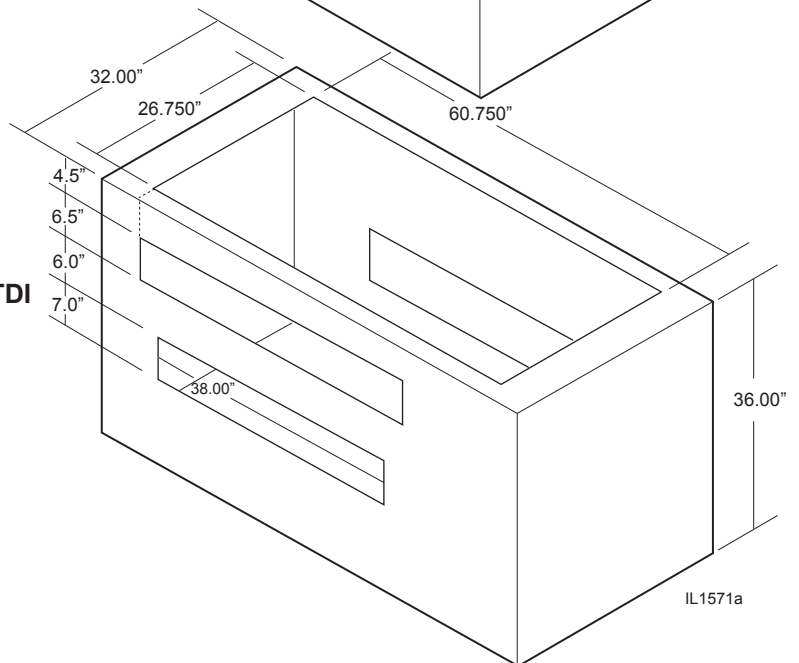

IL1571a

# INSTALLATION CONT.

## Install the Griddle into the Cabinet

Turn the griddle over, taking care not to kink or pinch any sensor wires. Set the griddle on the table that it is to be installed in (leaving a hole big enough to slip the control panel through).

Insert the control panel through the hole and out of the control opening of the cabinet.

The hole must be such that the control box can come out of the cabinet 18" for serviceability.

Lower the griddle plate to sit flat in the table opening.

## Electrical Connection

The electrical connection must be made in accordance with local codes or in the absence of local codes with NFPA No. 70; latest edition (in Canada use: CSA STD. C22.1).

A power connection box is provided for power connection.

This box must be installed a minimum of 18" from the heating elements in the cabinet box.

All electrical connections can be made at this box.

The griddle can now be connected to power.

**DANGER:** THIS APPLIANCE MUST BE GROUNDED AT THE TERMINAL PROVIDED. FAILURE TO GROUND THE APPLIANCE COULD RESULT IN ELECTROCUTION AND DEATH.



**WARNING**

INSTALLATION OF THE UNIT MUST BE DONE BY PERSONNEL QUALIFIED TO WORK WITH ELECTRICITY AND PLUMBING. IMPROPER INSTALLATION CAN CAUSE INJURY TO PERSONNEL AND/OR DAMAGE TO EQUIPMENT. UNIT MUST BE INSTALLED IN ACCORDANCE WITH ALL APPLICABLE CODES.

**NOTICE:** The data plate is located behind access panel between controls and grease drawer. The grill voltage, wattage, serial number, wire size, and clearance specifications are on the data plate. This information should be carefully read and understood before proceeding with the installation.

**NOTICE:** The installation of any components such as a vent hood, grease extractors, fire extinguisher systems, must conform to their applicable National, State and locally recognized installation standards.



**CAUTION**

ALWAYS KEEP THE AREA NEAR THE APPLIANCE FREE FROM COMBUSTIBLE MATERIALS.

KEEP FLOOR IN FRONT OF EQUIPMENT CLEAN AND DRY. IF SPILLS OCCUR, CLEAN IMMEDIATELY, TO AVOID THE DANGER OF SLIPS OR FALLS.



**WARNING**

BE SURE THE POWER SUPPLY VOLTAGE MATCHES THE VOLTAGE SPECIFIED ON THE NAMEPLATE LOCATED ON THE TOP OF THE CONTROL BOX



## INITIAL START UP

### Pre-Power On

Before turning the griddle on verify all electrical connections and remove excess shipping grease from the griddle surface.

### Turning the Power On

Set the main power switch, located at the far left of the control panel, to the “ON” (up) position (there are two “ON” switches on the 5 and 6-foot griddles).

Set each cooking section’s power switch, located next to each temperature dial, to the “ON” (up) position.

Set the temperature dials to 200°F (93°C).

Heat the griddle at 200°F (93°C) for 2 hours to evaporate any moisture that may be in the elements.

After 2 hours at 200°F (93°C), turn the griddle temperature up to 350°F (177°C) for 30 minutes.

After the griddle reaches 350°F (177°C) for 30 minutes, turn the griddle up another 50°F (10°C) for another 30 minutes and repeat this until the griddle is at 450°F (232°C) for 30 minutes

The griddle may emit a small amount of smoke as the cooking surface passes the 300°F (149°C) point. Do not be alarmed as the smoke is caused by oils associated with the manufacturing process and will stop when the griddle reaches 350°F (177°C).

### Season the Cooking Surface

The cooking surface must be “seasoned” in order to eliminate product sticking during cooking.

To season, heat the griddle to 250°F (121°C).

Once at 250°F (121°C), coat the cooking surface with non-salted vegetable oil.

Allow the griddle to stand at 250°F (121°C) until the cooking surface looks dry then coat it again.

Heat the griddle to 350°F (177°C) and repeat the procedure.

**NOTICE:** During the first few hours of operation you may notice a small amount of smoke coming off the griddle, and a faint odor from the smoke. This is normal for a new griddle and will disappear after the first few hours of use.

# OPERATION

## General

The suggested time and temperature chart (below) is provided as a guide for the products listed only.

If different temperature settings are to be used, select one side of the griddle and operate at the lowest temperature. Adjoining sections should be set at progressively higher temperatures.

Do not try to operate the end sections hot and the center sections cool.



### CAUTION

**ALWAYS KEEP THE AREA NEAR THE APPLIANCE FREE FROM COMBUSTIBLE MATERIALS.**

**KEEP FLOOR IN FRONT OF EQUIPMENT CLEAN AND DRY. IF SPILLS OCCUR, CLEAN IMMEDIATELY, TO AVOID THE DANGER OF SLIPS OR FALLS.**

### NOTICE

**Use only cleaners marked “SAFE ON ALUMINUM”**

## Operations

An understanding of how the griddle sections are controlled will be a valuable aid in loading product on your unit.

Each 12-inch section of your griddle is independently controlled by a temperature controller. The temperature control sensor is mounted in the center of each cooking section under the griddle plate.

If the product is loaded directly over the temperature sensor, that section will turn on and the burner will heat the entire cooking section. If the product is loaded to the side, front or back of the temperature sensor, the thermostat will react to the temperature change much slower.

During slow periods with minimal loads, do not load directly over the thermostat sensors as this will unnecessarily turn the burners on and overheat the remainder of the section not being utilized.

Turn the product and continue cooking until it is done.

Remove the product from the griddle.

When reloading the griddle, first use the griddle surface on which a previous load was not placed. This will help insure the proper griddle temperature.

### SUGGESTED TIMES AND TEMPERATURES

PRODUCTS	TEMPERATURE F / C	TIME (MIN)
HAMBURGER	350°F / 176°C	
2 patties per LB		6 to 8
4 patties per LB		4 to 6
6 patties per LB		3 to 4
STEAKS		
1/2 to 3/4 inch thick, cooked medium	375°F / 190°C	5 to 7
3/4 to 1 inch thick, cooked medium		8 to 10
Lamb Chops	350°F / 176°C	6 to 8
Pork Chops		6 to 8
Salmon	350°F / 176°C	6 to 8
Halibut	325°F / 162°C	6 to 8
Snapper		6 to 8
Hash Brown Potatoes	375°F / 190°C	3 to 4
Bacon	350°F / 176°C	3 to 4
Sausage Links or Patties		3 to 4
Ham (Pre-cooked)	375°F / 190°C	2
Eggs	275°F / 135°C	2 to 4
Note: The times and temperatures in this chart are intended as a general guide and starting point. Your actual times and temperatures may vary from this chart.		

## MAINTENANCE & CLEANING

### Cleaning

- Always start with a cold griddle.
- The stainless exterior can easily be cleaned using a good non-abrasive cleaner.
- Always follow the cleaner manufacturer's instructions when using any cleaner.
- Always apply these cleaners when the griddle is cold and rub in the direction of the metal's grain.

### Griddle Surface Care (non-chromium surfaces)

It takes very little time and effort to keep the griddle attractive and performing at top efficiency. If grease is permitted to accumulate, it will form a gummy cake and then carbonize into a hard substance which is extremely difficult to remove. To prevent this condition, the following suggestions for cleanliness should be followed:

- After each use, scrape the griddle with a scraper or flexible spatula to remove excess grease and food. A waste drawer is provided for the scrapings. If there is an accumulation of burned on grease and food, the griddle should be thoroughly scoured and re-seasoned. Use pumice or griddle stone while the griddle is warm.

Do not use steel wool because of the danger of steel slivers getting into the food.

### Carbon Cleaning

When carbon build up occurs, use a carbon removal agent according to the instructions provided with the cleaner. When this process is complete, you must re-season the grill according to your company/corporate guidelines, or the seasoning instructions in this manual

Always apply these cleaners when the griddle is cold and rub in the direction of the metal's grain.



**KEEP WATER AND SOLUTIONS OUT OF CONTROLS. NEVER SPRAY OR HOSE CONTROL CONSOLE.**

### WARNING



### CAUTION

**MOST CLEANERS ARE HARMFUL TO THE SKIN, EYES, MUCOUS MEMBRANES AND CLOTHING. PRECAUTIONS SHOULD BE TAKEN TO WEAR RUBBER GLOVES, GOGGLES OR FACE SHIELD AND PROTECTIVE CLOTHING. CAREFULLY READ THE WARNING AND FOLLOW THE DIRECTIONS ON THE LABEL OF THE CLEANER TO BE USED.**

**NOTICE: Never leave a chlorine sanitizer in contact with stainless steel surfaces longer than 10 minutes. Longer contact can cause corrosion.**

## MAINTENANCE & CLEANING CONT.

### CALIBRATION

#### Calibration Check

Place thermometer or thermocouple in the center of griddle directly over the sensor.

Set thermostat to 350°F (177°).

Allow the griddle to Preheat for at least 30 minutes.

Note cycle "ON" temperatures and cycle "OFF" temperatures for 3 cycles.  
(Red indicator light indicates when the griddle is calling for heat)

After 3 cycles average the temperature. (Add all six temperatures and divide by 6).  
The temp should be +/-10°F (-12°C).

#### Calibration Adjustment

A 1/16" flat blade screwdriver with a 2" shaft is required to make adjustments on the thermostat.

Maintain the griddle temperature at 350°F (177°C).

Without turning the thermostat, remove the knob.

Locate the adjustment screw at the base of the shaft and insert the screwdriver.

Grasp the shaft and turn the screwdriver. Counter clockwise to increase and clockwise to decrease  
(1/8 of a turn will move the temperature 5-7° (in either direction).

Reinstall the thermostat knob and recheck the griddle temperature.

# TROUBLESHOOTING

## Symptoms

What follows is a chart of Symptoms and Possible Causes to aid in diagnosing faults with the griddle.

Refer to the Symptoms column to locate the type of failure then to the Possible Cause for the items to be checked.

To test for a possible causes refer to the TEST section and locate the Possible Cause then refer to test to identify test procedures.

SYMPTOM	POSSIBLE CAUSE
Griddle will not heat	<ul style="list-style-type: none"> <li>No power to unit</li> <li>Defective thermostat</li> <li>Defective element</li> </ul>
Product is under cooked	<ul style="list-style-type: none"> <li>No power to griddle</li> <li>Thermostat out of calibration</li> </ul>
	<ul style="list-style-type: none"> <li>Defective thermostat</li> </ul>
Product is burning	<ul style="list-style-type: none"> <li>Thermostat out of calibration</li> </ul>
	<ul style="list-style-type: none"> <li>Defective thermostat</li> </ul>

POSSIBLE CAUSE	TEST
Product is cooked too long	<ul style="list-style-type: none"> <li>No test available, operational condition</li> </ul>
Failed thermostat	<ul style="list-style-type: none"> <li>Verify calibration</li> <li>Replace thermostat*</li> </ul>
Failed element	<ul style="list-style-type: none"> <li>Remove the wires and check for continuity across the element *</li> <li>Replace element*</li> </ul>

**NOTICE:** Service on this, or any other, LANG appliance must be performed by qualified personnel only. Consult your Lang Authorized Service Agent Directory or call the factory at 314-678-6315, or [www.langworld.com](http://www.langworld.com) For the service agent nearest you.



**BOTH HIGH AND LOW VOLTAGES ARE PRESENT INSIDE THIS APPLIANCE WHEN THE UNIT IS PLUGGED/WIRED INTO A LIVE RECEPTACLE. BEFORE REPLACING ANY PARTS, DISCONNECT THE UNIT FROM THE ELECTRIC POWER SUPPLY.**

If an item on the list is followed by an asterisk (\*), the work should be done by a factory authorized service representative.



**USE OF ANY REPLACEMENT PARTS OTHER THAN THOSE SUPPLIED BY LANG OR THEIR AUTHORIZED DISTRIBUTORS CAN CAUSE BODILY INJURY TO THE OPERATOR AND DAMAGE TO THE EQUIPMENT AND WILL VOID ALL WARRANTIES.**

Revision Block		DESCRIPTION	DR.	MFG.	DATE
REV	ECN NO.	REVISED AND REDRAWN	CDS		10/15/2002
E		ADDED 220VAC FOR LGCL	DLG		12/13/2002
F		ADDED WIRING FOR 2 POLE TSTAT	DJS		10/1/2007
G	6170				

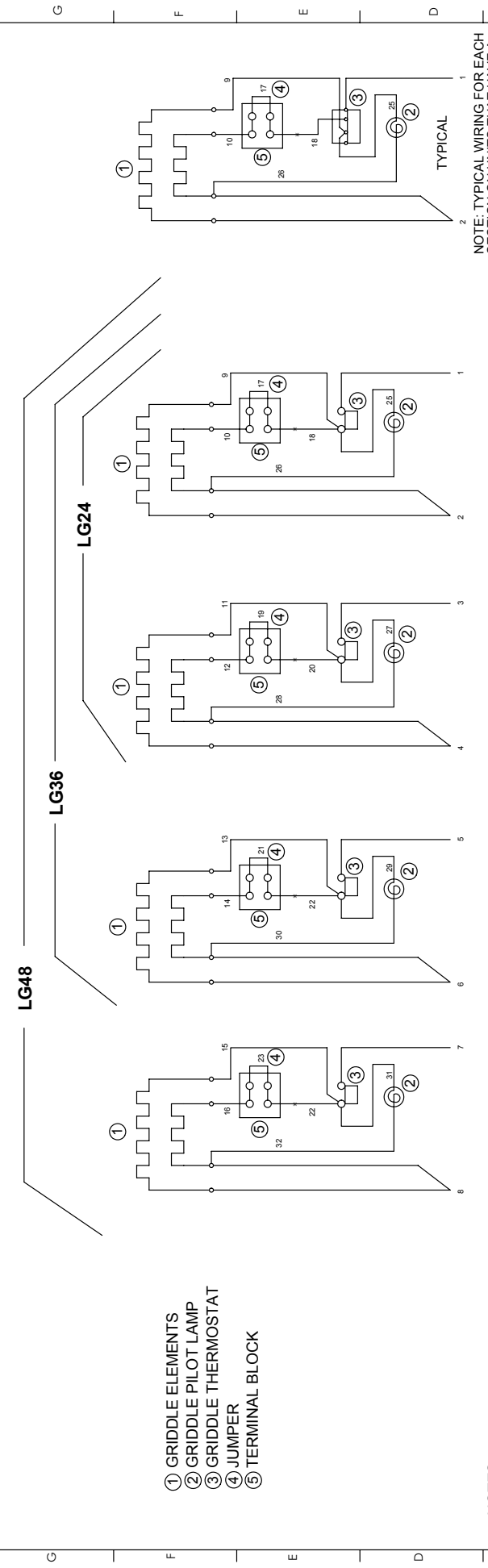

NOTE: TYPICAL WIRING FOR EACH SECTION ON UNITS THAT HAVE A 2 POLE THERMOSTAT.

- ① GRIDDLE ELEMENTS
- ② GRIDDLE PILOT LAMP
- ③ GRIDDLE THERMOSTAT
- ④ JUMPER
- ⑤ TERMINAL BLOCK

NOTES:  
 LG60 & LG72 HAVE TWO POWER SUPPLY CONNECTIONS  
 LG60: CONN #1 USE LG36  
 CONN #2 USE LG24  
 LG72: CONN #1 USE LG36  
 CONN #2 USE LG36

ELEMENT HOOKUP	
208-220 V	240V
INSTALL	REMOVE
JUMPER	JUMPER
(ITEM 4)	(ITEM 4)

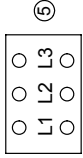

MODEL	VOLT	Kw			TOTAL	AMP TOTALS			AMPS 1 PHASE			SERVICE CONNECTIONS			
		L1-L3	L2-L3	L1-L3		L1	L2	L3	L1	L2	L3	L1	L2	L3	
LG24	208	6.0	6.0	6.0	12.0	50.0	28.9	28.9	57.7						
	220	6.7	6.7	6.7	13.4	52.9	30.5	30.5	60.9	1.4	2	3	1.3	2.4	
	240	6.0	6.0	6.0	12.0	43.3	25.0	25.0	50						
LG36	208	6.0	6.0	6.0	18.0	50.0	50.0	50.0	86.5						
	220	6.7	6.7	6.7	20.1	52.9	52.9	52.9	91.4	1.4	2.5	3.6	1.3,5	2.4,6	
	240	6.0	6.0	6.0	18.0	43.3	43.3	43.3	75						
LG48	208	12.0	6.0	6.0	24.0	76.0	76.3	50.0	115.4	1.4,7	2.5,8	3.6	1.3,5,7	2.4,6,8	
	220	13.4	6.7	6.7	26.8	80.6	80.6	52.9	121.8						
	240	12.0	6.0	6.0	24.0	66.1	43.3	100							

Lang Manufacturing Company

DESCRIPTION: LANG GRIDDLE 208-240/220VAC

DWG. NO: 61114-01

REV: G

SHEET 1 OF 1

DATE: 12-13-02

REV. BY: DLG

CHK. BY: DLG

8 7 6 5 4 3 2 1

REVISIONS	
REV.	DESCRIPTION OF CHANGE
C	DATE/ECO 10/15/02 REVISED & REDRAWN
D	DATE/ECO 2/8/2008 ECC# 6574 ADDED 380V MODEL, REVISED NOTES, REMOVED AMP TABLE

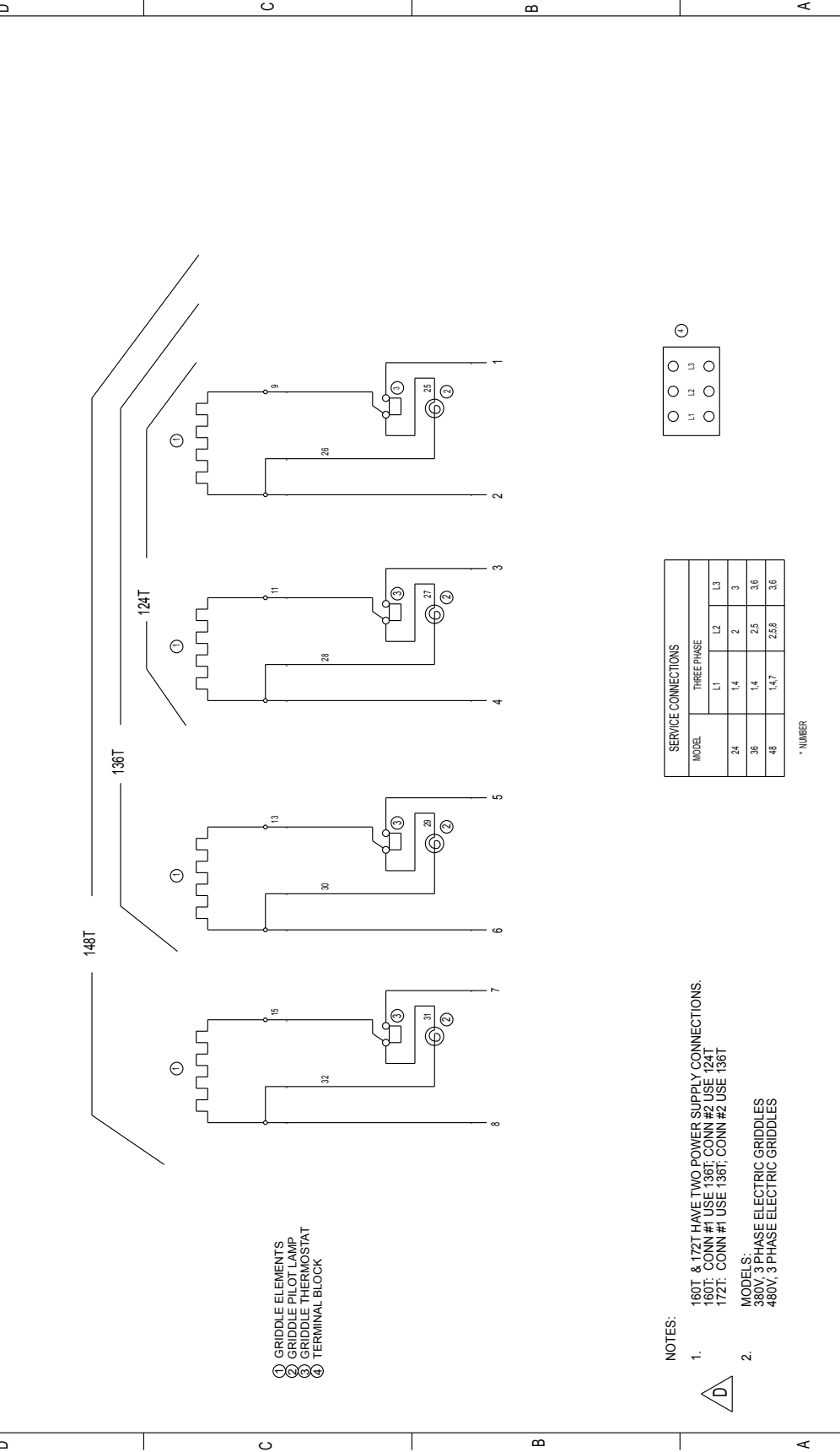

- NOTES:
1. 160T & 172T HAVE TWO POWER SUPPLY CONNECTIONS.  
160T: CONN #1 USE 136T, CONN #2 USE 124T  
172T: CONN #1 USE 136T, CONN #2 USE 136T
  2. MODEL S:  
380V, 3 PHASE ELECTRIC GRIDDLES  
480V, 3 PHASE ELECTRIC GRIDDLES

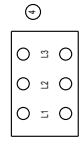

SERVICE CONNECTIONS	
MODEL	THREE PHASE
24	L1 L2 L3
36	L1 L2 L3
48	L1 L2 L3

\* NUMBER

		MATERIAL PART #: DIM. BY: CDS / DIM. DATE: 10/15/02 / REV. DATE:		MATERIAL TYPE: BLANK DIMS.: X		BLANK AREA:		SHEET 1 OF 1	
DESCRIPTION: WD LANG GRIDDLE 380 & 480 VAC ACCUTEMP		DIM. BY: CDS / DIM. DATE: 10/15/02 / REV. DATE:		MATERIAL TYPE:		BLANK DIMS.: X		SHEET 1 OF 1	
DWG. NO: 61114-02		REV. DATE:		CHK. BY:		CAD FILE:		REV. D	

UNLESS OTHERWISE SPECIFIED  
DIMENSIONS ARE IN INCHES.  
TOLERANCES ARE:  
DECIMALS .015  
ANGLES ± .5°  
XX ± .005  
XXX ± .015

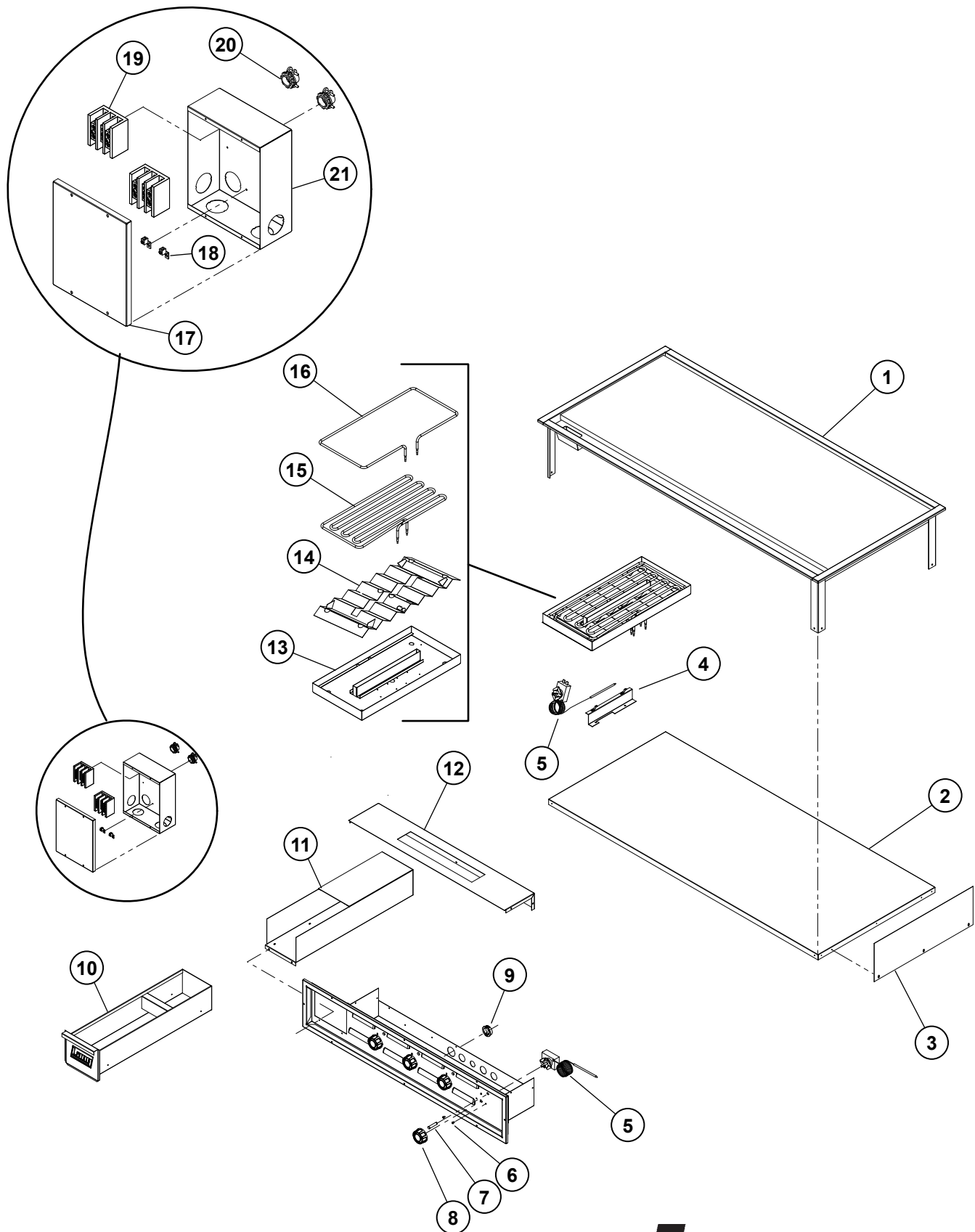

136TDI - 160TDI Drop-In Electric Griddle  
LGD Drop-In Electric Griddle

**Lang**<sup>®</sup>

SK2403 Rev. A 6/15/2015



# PARTS LIST

October 5, 2012, Rev D

Model: 136TDI, 148TDI, 160TDI Drop-In Electric Griddle				
Fig No	Part Number	Qty	Description	Application
1	K9-LGD-147-3	1	WELD PLATE 3' ACU	136TDI
	K9-LGD-147-31		WELD PLATE 3' ACU CROME	136TDIC-480V
	K9-LGD-147-4		WELD PLATE 4' ACU	148TDI
	K9-LGD-147-5		WELD PLATE 5' ACU	160TDI
2	K9-LGD-150-3	1	BOTTOM 3'	136TDI
	K9-LGD-150-4		BOTTOM 4'	148TDI
	K9-LGD-150-5		BOTTOM 5'	160TDI
3	K9-LGD-155	1	BODY SIDE RH	ALL
4	K9-XL-506	3	STAT HOLDER	136TDI
		4		148TDI
		5		160TDI
5	2T-30402-08	2	STAT ADJ 450o 72 C/T	136TDIC-480V
		3		136TDI, 136TDIC
		4		148TDI
		5		160TDI
	2T-30402-41	1	STAT ADJ 600° 72" C/T (CENTER)	136TDIC-480V
6	2C-20101-77	6	SCRW MS PLT 6-32 X .25 PHD	
7	Y9-31601-01-1	3	PILOT LT 250V w/TIN CLIP	136TDI, 136TDIC
		5		148TDI
		6		160TDI
	Y9-31601-02-1	3	PILOT LT 480V w/TIN CLIP	136TDI-480V, 136TDIC-480V
		5		148TDI-480V
8	Y9-70701-12 (Black), Y9-70701-12-2 (Red)	1	KNOB ASSEMBLY 550° (CENTER)	136TDIC-480V
	Y9-70701-16 (Black), Y9-70701-16-2 (Red)	3	KNOB ASSEMBLY 450o A	136TDI, 136TDIC
		4		148TDI
		5		160TDI
9	2K-70801-02	2	SNAP BUSH 1 3/8 SB1375-16	148TDI
10	K9-LGD-228	1	GREASE BUCKET ASSY	ALL
11	K9-LGD-220	1	GREASE BUCKET SLIDE WELD	ALL
12	K9-LGD-303-3	1	COUNTER COVER 3'	136TDI
	K9-LGD-303-4		COUNTER COVER 4'	148TDI
	K9-LGD-303-5		COUNTER COVER 5'	160TDI
13	K9-XL-434	3	ELEMENT PAN ASSEMBLY	136TDI
		4		148TDI
		5		160TDI
14	K9-XL-439	3	ELEMENT PAN Z ASSEMBLY	136TDI
		4		148TDI
		5		160TDI
15	2N-11030-29	3	ELE GRD 208/240V4.5KW/6KW	136TDI, 136TDIC
		4		148TDI
		5		160TDI

**IMPORTANT: WHEN ORDERING, SPECIFY VOLTAGE OR TYPE GAS DESIRED  
INCLUDE MODEL AND SERIAL NUMBER**

PAGE 1  
OF 2

Some items are included for illustrative purposes only and in certain instances may not be available.

# PARTS LIST

October 5, 2012, Rev D

Model: 136TDI, 148TDI, 160TDI Drop-In Electric Griddle				
Fig No	Part Number	Qty	Description	Application
16	2N-11030-30	3	ELMNT GRID 208V 1257W	136TDI, 136TDIC
		4		148TDI
		5		160TDI
	2N-11030-31	3	ELMND GRID 480V 5991W	136TDI-480V, 136TDIC-480V
		4		148TDI-480V
		5		160TDI-480V
17	K9-LGD-311-1	1	POWER BOX COVER	ALL
18	2E-31200-08	3	LUG GROUNDING TWO HOLE	
19	2E-30500-07	2	TRM BLOCK 3PLELRGE 125AMP	136TDI, 136TDIC, 160TDI
		6		148TDI
20	2E-31200-01	1	BOX CONNECTOR 3/8	
21	K9-LGD-311	1	POWER SUPPLY BOX	ALL
NI	2E-30500-02	2	TRM STRP 4 POLE 30A 600V	148TDI
NI	2E-30500-03	1	TRM STRP 6 POLE 30A 300V	136TDI, 136TDIC
NI	2E-30500-07	2	TRM BLOCK 3PLELRGE 125AMP	
NI	2H-XL-424	2	ELEMENT PAN INSULATION	136TDI
		4		148TDI
		5		160TDI
NI	K9-XL-426	3	ELEMENT PAN PLATE	136TDI, 136TDIC
		4		148TDI
		5		160TDI
NI	2I-72602-19	AR	GASKET TUBE .375 OD x .25 IN (sold by foot)	

**IMPORTANT: WHEN ORDERING, SPECIFY VOLTAGE OR TYPE GAS DESIRED  
INCLUDE MODEL AND SERIAL NUMBER**

PAGE 2  
OF 2

Some items are included for illustrative purposes only and in certain instances may not be available.





**STAR INTERNATIONAL HOLDINGS INC. COMPANY**

Star - Holman - Lang - Wells - Bloomfield - Toastmaster

10 Sunnen Drive, St. Louis, MO 63143 U.S.A.