

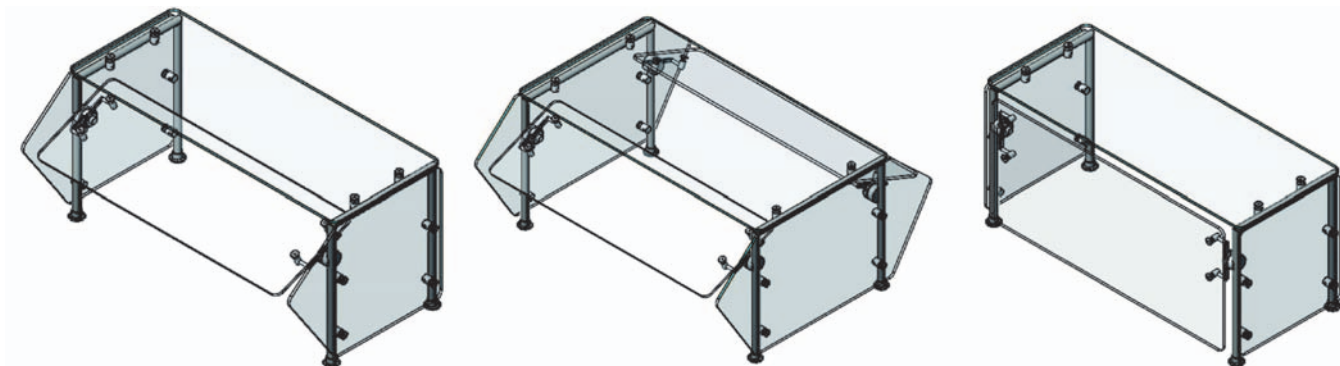

# Care and Use Instructions

## Velocity Adjustable Breath Guards



### ADJUST THE GLASS PANEL

#### Rotate the Glass Up

1. Grasp the lower edge of the glass panel and gently push the glass up.

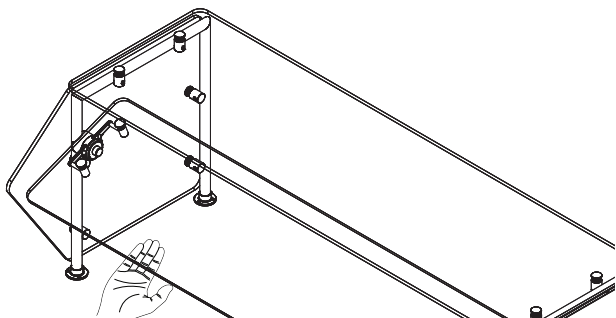

2. The adjustment mechanism will click when it locks into a position.

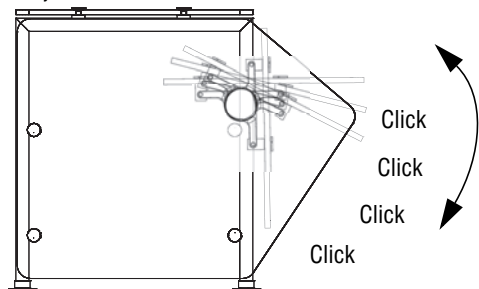

#### Rotate the Glass Down

Note: The glass rotates down in 90° increments from the current position. If starting with the glass at a position other than 90°, you will need to push the release button more than once.

1. Rotate the glass panel so that it is parallel to the countertop below.

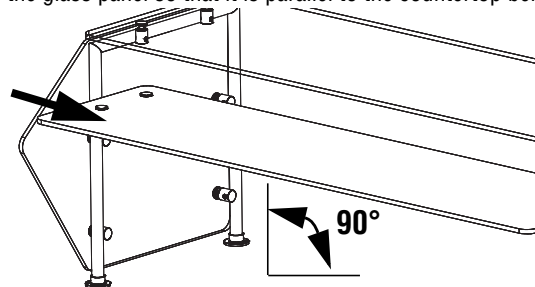

2. Gently lift the glass to reduce the weight resting on the locking hinge and press the release button.

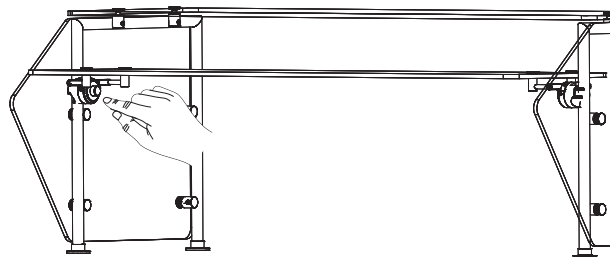

3. Lower the glass panel.

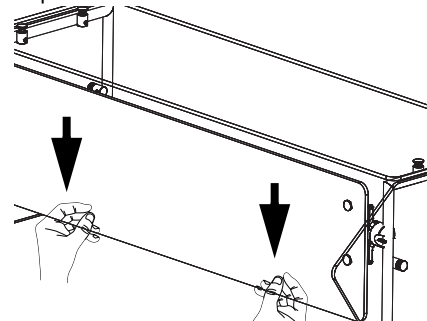

---

## NSF POSITIONING

---

### NSF 2 Position

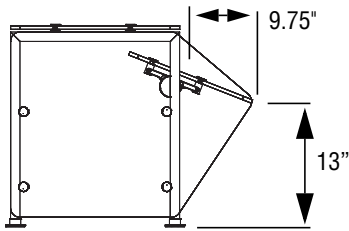

To comply with NSF 2, the leading edge of the Adjustable Breath Guard must be a maximum of 13" from the countertop and extend outwards a minimum of 9.75".

1. Rotate the glass panel so that it is perpendicular to the countertop.
2. Raise the glass panel until the notches on the adjustment mechanism align as shown below.

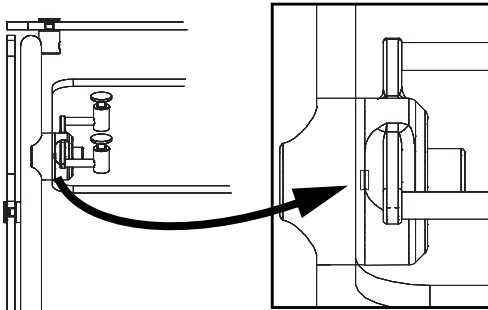

3. When the notches align, the Adjustable Breath Guard is in the correct NSF 2 position.

---

## CLEAN

---

### Glass Panels

- Use a food-safe glass cleaner or a mild soap and water solution.

### Metal Frame

**NOTICE:** Do not use abrasive materials, scratching cleansers, brushes, steel wool or scouring pads. These could damage the finish.

**NOTICE:** Notice do not saturate the adjustment mechanism.

- Use mild soap and water and a soft cloth to wipe the frame.
- Use a clean soft cloth dipped in clean water to wipe away any soap residue.
- Use a clean soft cloth to dry the metal frame.

---

## SERVICE AND REPAIR

---

Serviceable parts are available on [Vollrath.com](http://Vollrath.com).

To avoid serious injury or damage, never attempt to repair the unit or replace a damaged power cord yourself. Do not send units directly to The Vollrath Company LLC. Please contact Vollrath Technical Services for instructions.

When contacting Vollrath Technical Services, please be ready with the item number, model number (if applicable), serial number, and proof of purchase showing the date the unit was purchased.

---

## WARRANTY STATEMENT FOR THE VOLLRATH CO. L.L.C.

---

This warranty does not apply to products purchased for personal, family or household use, and The Vollrath Company LLC does not offer a written warranty to purchasers for such uses.

The Vollrath Company LLC warrants the products it manufactures or distributes against defects in materials and workmanship as specifically described in our full warranty statement. In all cases, the warranty runs

from the date of the end user's original purchase date found on the receipt. Any damages from improper use, abuse, modification or damage resulting from improper packaging during return shipment for warranty repair will not be covered under warranty.

For complete warranty information, product registration and new product announcement, visit [www.vollrathfoodservice.com](http://www.vollrathfoodservice.com).



[www.vollrathfoodservice.com](http://www.vollrathfoodservice.com)

### The Vollrath Company, L.L.C.

1236 North 18th Street  
Sheboygan, WI 53081-3201 U.S.A.  
Main Tel: 800.624.2051 or 920.457.4851  
Main Fax: 800.752.5620 or 920.459.6573  
Customer Service: 800.628.0830  
Canada Customer Service: 800.695.8560

### Technical Services

[techservicereps@vollrathco.com](mailto:techservicereps@vollrathco.com)  
Induction Products: 800.825.6036  
Countertop Warming Products: 800.354.1970  
Toasters: 800-309-2250  
All Other Products: 800.628.0832