

Champion®

Installation/Operation and Service Parts Manual

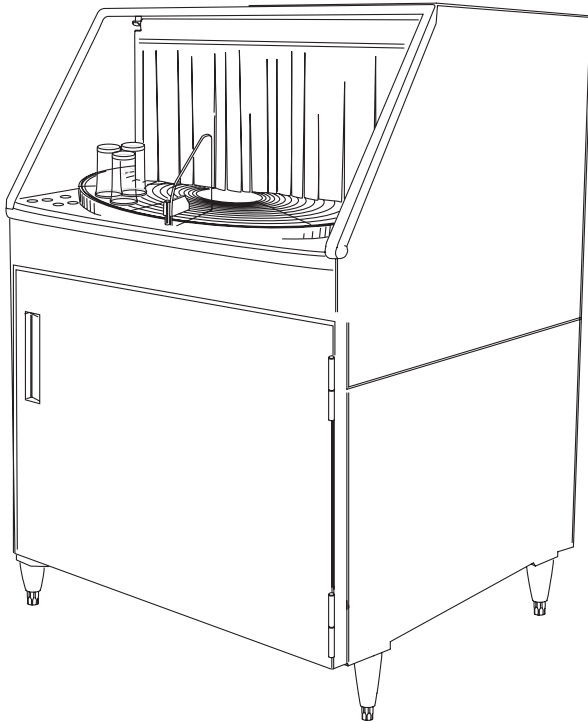

Rotary-type Conveyor Glasswasher

Model:

CGM7.5

Clockwise Rotation



Issue Date: 11.29.16

Manual P/N 0514433 rev. -

For machines beginning with S/N G016052106

3765 Champion Boulevard
Winston-Salem, NC 27105
(336) 661-1992 Fax: (336) 661-1660
Toll-free: (800) 858-4477

2674 N. Service Road, Jordan Station
Ontario, Canada L0R 1S0
(905) 562-4195 Fax: (905) 562-4618
Toll-free: (800) 263-5798

Printed in the USA



National Service Department

In Canada:

Toll-free: 800/ 263-5798

Tel: 905/ 562-4195

Fax: 905/ 562-4618

email: service@moyerdiebellimited.com

In the USA:

Toll-free: 800/ 858-4477

Tel: 336/ 661-1992

Fax: 336/ 661-1660

email: service@championindustries.com

ATTENTION:

The glasswasher model no., serial no., voltage, Hz and phase are needed to identify your machine and to answer questions.

Please have this information on-hand if you call for service assistance.



REGISTER YOUR PRODUCT to ACTIVATE YOUR WARRANTY.

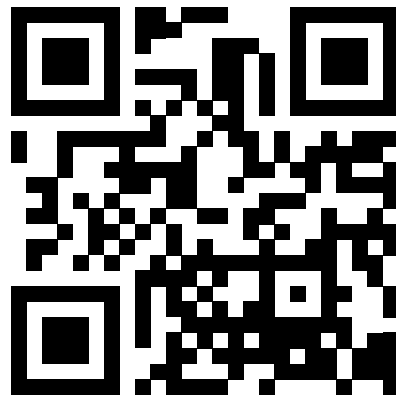
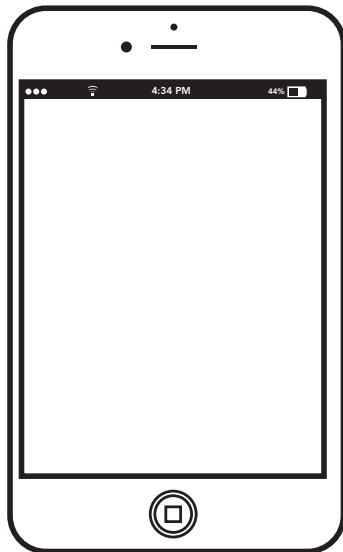

Three ways to register:

- Use your mobile device to scan the QR code located on the front panel of your machine or enter our URL <http://www.champdw.us/CG>.
- Visit our website at:
<http://www.championindustries.com/warranty-registration>
- Use the FAX FORM on the next page.

Champion[®]

PRODUCT REGISTRATION BY FAX

COMPLETE THIS FORM AND FAX TO:

(336) 661-1660 in the USA

1-(800) 204-0109 in Canada

PRODUCT REGISTRATION CARD

Model

Serial #

Date of Installation: ___/___/___

Company Name: _____

Address: _____
(Street) Province Postal Code

Telephone #: () _____ --- _____

Contact: _____

Installation Company: _____

Address: _____

Telephone #: _____

Contact: _____

FAILURE TO REGISTER YOUR PRODUCT MAY VOID YOUR WARRANTY

IMPORTANT IMPORTANT

Revision History

We reserve the right to make changes to this manual without notice and without incurring any liability by those changes. Equipment owners may request a revised manual, at no charge, by calling 1 (800) 858-4477 in the USA or by calling 1 (800) 263-5798 in Canada.

<i>Revision Date</i>	<i>Revised Pages</i>	<i>Serial Number Effectivity</i>	<i>Revision Description</i>
11.29.16	All	G016052106	Released CGM7.5 version

LIMITED WARRANTY

Champion Industries. (herein referred to as The Company), 3765 Champion Blvd., Winston-Salem, North Carolina 27105, and 2674 N. Service Road, Jordan Station, Canada, LOR 1S0, warrants machines, and parts, as set out below.

Warranty of Machines: The Company warrants all new machines of its manufacture bearing the name "Champion" and installed within the United States and Canada to be free from defects in material and workmanship for a period of one (1) year after the date of installation or fifteen (15) months after the date of shipment by The Company, whichever occurs first. [See below for special provisions relating to glasswashers.] Warranty registration must be submitted to Champion within ten (10) days after installation either online at <http://www.championindustries.com/warranty-registration> or by fax on the form provided at the front of this manual. If warranty registration is not returned to The Company within such period, the warranty will expire after one year from the date of shipment. The Company will not assume any responsibility for extra costs for installation in any area where there are jurisdictional problems with local trades or unions. If a defect in workmanship or material is found to exist within the warranty period, The Company, at its election, will either repair or replace the defective machine or accept return of the machine for full credit; provided; however, as to glasswashers, The Company's obligation with respect to labor associated with any repairs shall end (a) 120 days after shipment, or (b) 90 days after installation, whichever occurs first. In the event that Champion elects to repair, the labor and work to be performed in connection with the warranty shall be done during regular working hours by The Company's authorized service technician. Defective parts become the property of The Company. Use of replacement parts not authorized by The Company will relieve The Company of all further liability in connection with its warranty. In no event will The Company's warranty obligation exceed The Company's charge for the machine. The following are not covered by The Company's warranty:

- a. Lighting of gas pilots or burners.
- b. Cleaning of gas lines.
- c. Replacement of fuses or resetting of overload breakers.
- d. Adjustment of thermostats.
- e. Adjustment of clutches.
- f. Opening or closing of utility supply valves or switching of electrical supply current.
- g. Cleaning of valves, strainers, screens, nozzles, or spray pipes.
- h. Performance of regular maintenance and cleaning as outlined in operator's guide.
- i. Damages resulting from water conditions, accidents, alterations, improper use, abuse, tampering, improper installation, or failure to follow maintenance and operation procedures.
- j. Wear on Pulper cutter blocks, pulse vanes, and auger brush.

Examples of the defects not covered by warranty include, but are not limited to: (1) Damage to the exterior or interior finish as a result of the above, (2) Use with utility service other than that designated on the rating plate, (3) Improper connection to utility service, (4) Inadequate or excessive water pressure, (5) Corrosion from chemicals dispensed in excess of recommended concentrations, (6) Failure of electrical components due to connection of chemical dispensing equipment installed by others, (7) Leaks or damage resulting from such leaks caused by the installer, including those at machine table connections or by connection of chemical dispensing equipment installed by others, (8) Failure to comply with local building codes, (9) Damage caused by labor dispute.

Warranty of Parts: The Company warrants all new machine parts produced or authorized by The Company to be free from defects in material and workmanship for a period of 90 days from date of invoice. If any defect in material and workmanship is found to exist within the warranty period The Company will replace the defective part without charge.

DISCLAIMER OF WARRANTIES AND LIMITATIONS OF LIABILITY. THE COMPANY'S WARRANTY IS ONLY TO THE EXTENT REFLECTED ABOVE. THE COMPANY MAKES NO OTHER WARRANTIES, EXPRESS OR IMPLIED, INCLUDING, BUT NOT LIMITED, TO ANY WARRANTY OF MERCHANTABILITY, OR FITNESS OF PURPOSE. CHAMPION INDUSTRIES SHALL NOT BE LIABLE FOR INCIDENTAL OR CONSEQUENTIAL DAMAGES. THE REMEDIES SET OUT ABOVE ARE THE EXCLUSIVE REMEDIES FOR ANY DEFECTS FOUND TO EXIST IN THE COMPANY'S DISHWASHING MACHINES AND THE COMPANY'S PARTS, AND ALL OTHER REMEDIES ARE EXCLUDED, INCLUDING ANY LIABILITY FOR INCIDENTALS OR CONSEQUENTIAL DAMAGES.

Champion Industries does not authorize any other person, including persons who deal in Champion Industries dishwashing machines to change this warranty or create any other obligation in connection with Champion Industries Dishwashing Machines.

Table of Contents

Revision History	i
Limited Warranty	ii
Specifications	iv
Installation	1
Unpacking	1
Utility Connections	3
Chemicals.....	4
Flow Diagram	6
Quick Operation Guide.....	7
Operation	8
Assembling the Glasswasher	8
Filling the Wash Tank	8
Operating Instructions	8
Cleaning	15
Daily Cleaning or after 8 hours of operation	15
Weekly Cleaning or 56 hours of operation	10
Troubleshooting	12
Service Replacement Parts.....	17
Electrical Schematic	42

CG

Rotary Type Series
Fully Automatic
Glasswashing Machine

Champion®

The Dishwashing Machine Specialists

Dimensions shown in inches and [millimeters]

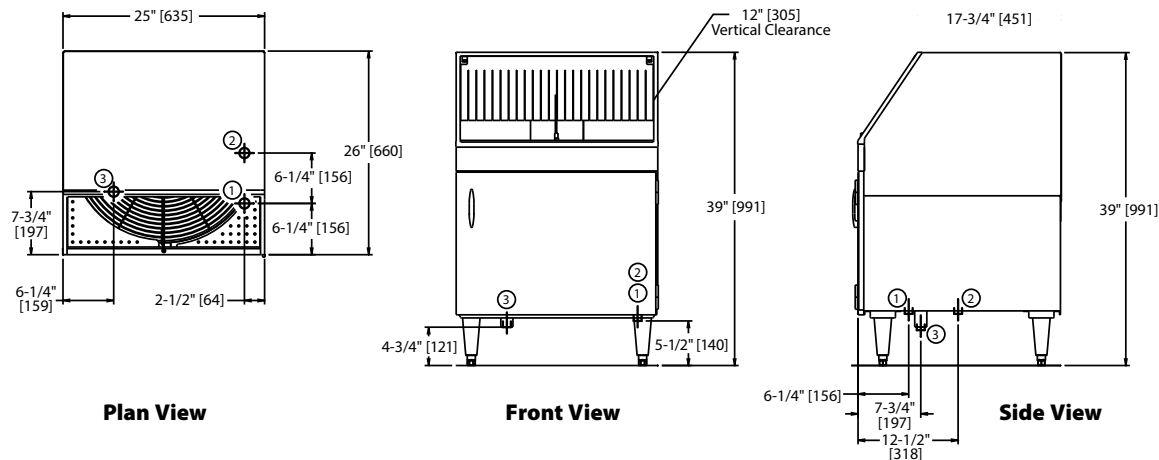

Utilities	
	* Electrical 208 - 230/60/1, 15 amp
1	Hot water 1/2" IPS. Flow pressure 25-95 psi
2	Cold water 1/2" IPS. Flow pressure 25-95 psi
3	Drain 1-1/2" tailpiece. Connect to drain size according to local plumbing code.

* **NOTE:** CG models supplied with 6 ft. plug-in cord (NEMA 6-15P).

Warning: Plumbing and electrical connections should be made by qualified personnel who will observe all the applicable plumbing, sanitary and safety codes.

	Uncrated	Crated
Height	39"	46-1/2"
Width	25-1/4"	27"
Depth	26"	27-1/2"
Ship Wt. lbs/kg	156	176

* Adjustable foot height - 1-1/4"

SPECIFICATIONS	
Capacity (hr.)	1200
2-1/2" glasses/hr.	
Conveyor Movement	Clockwise
CG	
Water consumption	
Cold Water (approx.) 2.5 gpm	
Hot Water (initial fill) 3 gpm	
(Max. use - approx. 10 gph)	
Temperatures °F	
Inlet water (hot) 140-160	
Inlet water (cold) 75	
Heating	
Tank heat, electric, (kW) 3	
Clearance	
Through machine (inches) 12	

Due to an ongoing value analysis program at Champion, specifications contained in this catalog are subject to change without notice.

Champion Industries, Inc., 3765 Champion Blvd., Winston-Salem, NC 27105 • 336/661-1556 • Fax: 336/661-1979 • www.championindustries.com

Installation

Unpacking

1. Move the glasswasher to its permanent location.
2. Open the door and remove the box marked "LEGS". The box contains (4) 6" [152cm] screw-in legs. These legs are threaded tightly into the base of the machine.
3. Remove (2) 1/2-13 x 2" bolts holding the glasswasher to the pallet.
4. Lift the front door off the bottom hinges and set carefully aside.
5. The illustrations below show one method to install the legs without lifting the glasswasher completely off the pallet.

NOTE:



The installation of the dishwasher must comply with all local electrical, plumbing, health and safety codes or in the absence of local codes, installed in accordance with the applicable requirements in the National Electrical Code, NFPA 70, Canadian Electrical Code (CEC), Part 1, CSA C22.1; and the Standard for Ventilation Control and Fire Protection of Commercial Cooking Operations, NFPA 96.

CAUTION:



The glasswasher water inlet plumbing and the drain piping extend below the pallet. Use extreme care when moving the glasswasher to prevent damage to the glasswasher plumbing.

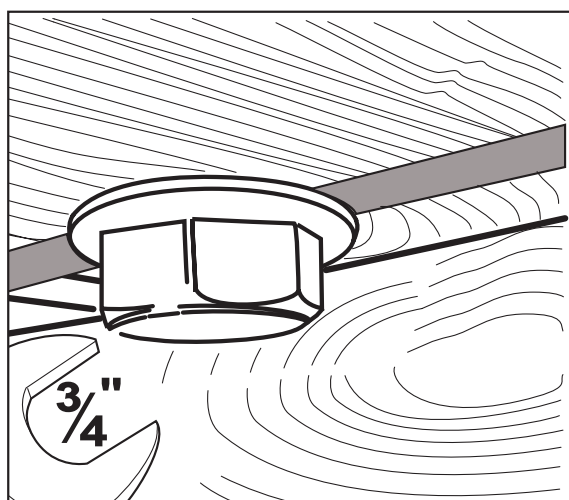

Remove the (2) pallet bolts holding the glasswasher to the pallet.

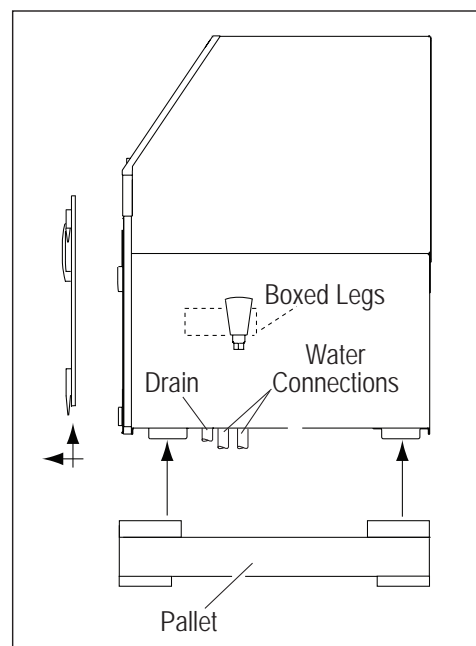

Glasswasher plumbing connections extend below the pallet.

Continued on the next page.

Installation

Unpacking (continued)

6. Use two people to move the machine in order to install the legs.
7. Have one person behind the glasswasher tilt it back as the person in front twists the machine to the right. This makes the front left leg mounting hole accessible.
8. Screw one of the legs tightly into place. Repeat this process for the remaining legs.
9. Lift the glasswasher off the pallet, and re-install the front door..
10. Level the glasswasher front-to-back and side-to-side by adjusting the leg bullet feet in or out.
11. Compare the site utilities with the data plate specifications. If they agree, then proceed with the installation according to the diagrams on the next page.
12. Remove the packing material in the glasswasher and discard, then remove any protective film on the machine.

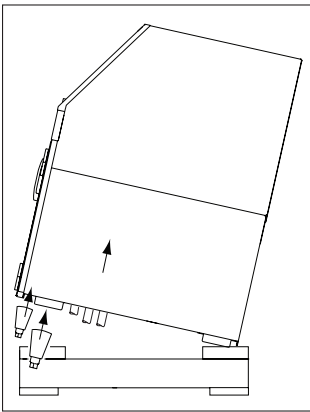

Tilt the machine back to clear plumbing connections.

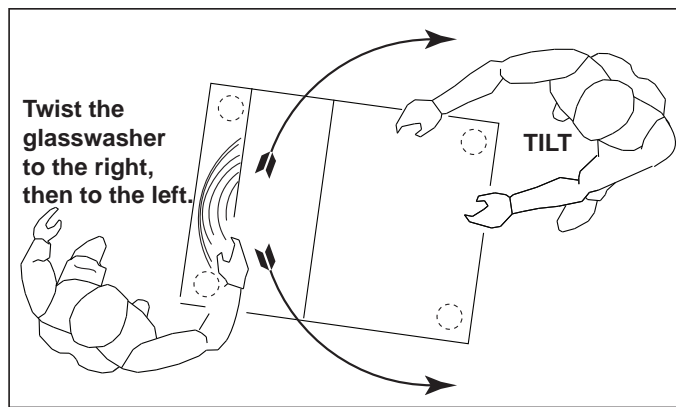

Twist the machine to the right until the front right leg mounting hole is accessible.

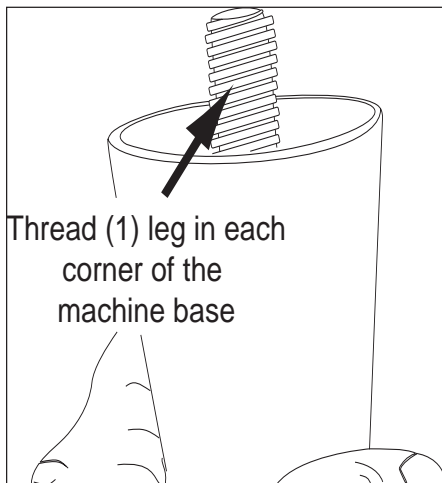

Thread (1) leg in each corner of the machine base

Make sure to install the legs tightly.

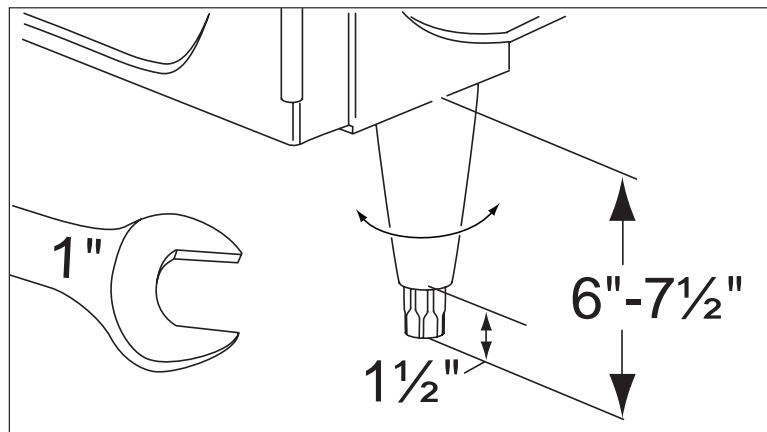

Level front-to-back and side-to-side

Utility Connections



The installation of this machine must be performed by personnel who will follow all safety, electrical, plumbing, and sanitation codes.

HOT WATER CONNECTION:

140-160°F/60-71°C

1/2" IPS

Flow Pressure 25-95 PSI [173-655 kPa]

1

Install water shut-off valves and check-valves in the water inlet supply lines and as close to the machine as possible.

COLD WATER CONNECTION:

75°F/24°C

1/2" IPS

Flow Pressure 25-95 PSI [173-655 kPa]

2

Install water shut-off valves and check-valves in the water inlet supply lines and as close to the machine as possible.

DRAIN CONNECTION:

Gravity

1-1/2" Tailpiece (slip-fit)

Maximum drain flow 3 US gallons/min [11L/min].

3

ELECTRIC CONNECTION:

208-230VAC/50-60Hz/1PH

Min/Max 15A

6ft./1.5m flexible cord and plug supplied

NEMA 6-15P electric outlet.

4

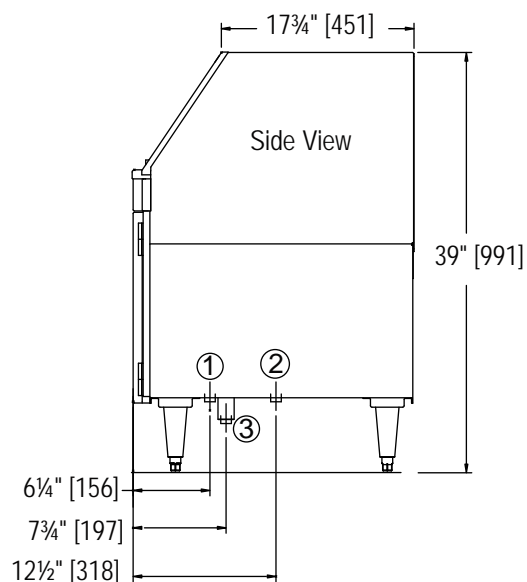
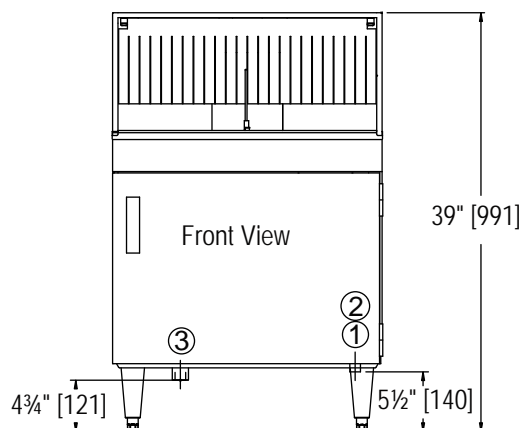
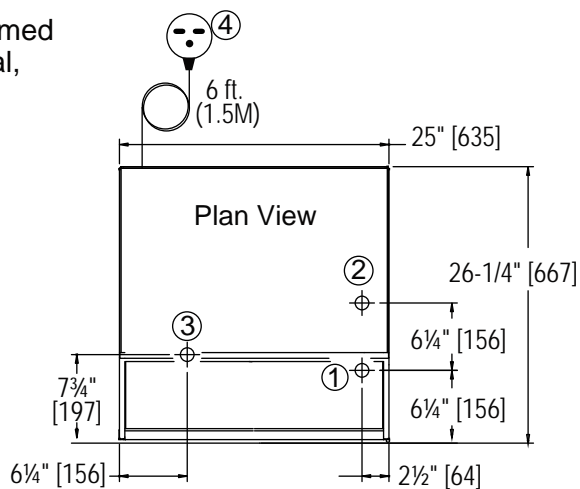

Installation (continued)

Chemicals

Glassware cleaning chemicals

1. A qualified chemical supplier should supply liquid detergent, sanitizer and rinse-aid for the glasswasher. The glasswasher manufacturer does not sell glassware washing chemicals.
2. A chemical's formulation and strength vary depending on the chemical supplier; therefore, the specifications given below are approximations only.
3. The glasswasher has 3 built-in chemical dispensing pumps for

Detergent - Use a commercial grade non-chlorinated detergent specifically made for glasswashers. The recommended concentration of detergent should be .35%

Sanitizer - 2 types of sanitizer may be used.

(5.25%) Sodium hypochlorite (*chlorine bleach*) to provide a minimum concentration of 50 ppm in the final rinse. The 50 ppm concentration must be checked using test strips to make sure the proper concentration is maintained.

Iodophor (*Iodine formulated with a rinse agent*), to provide a minimum concentration of 12.5ppm in the final rinse. The 12.5 ppm concentration must be checked using test strips to make sure the proper concentration is maintained.

Rinse-aid - Consult your chemical supplier for the proper type of rinse-aid to use in the glasswasher.

Installing chemical supply containers and chemical pick-up tubes

1. There is enough space inside the lower compartment to hold 3 one gallon containers for detergent, sanitizer, and rinse-aid.

The contents of each container must be marked clearly.

2. The glasswasher comes equipped with 3 gray tubes, called stiffener tubes, and tubing for each chemical pump. The tubing inserted in the chemical container has a strainer.
3. The outlet tubes from the supply containers to the chemical pumps are marked with color-coded labels, they are:

RED -	Detergent	(DET)
CLEAR -	Sanitizer	(SAN)
BLUE -	Rinse-aid	(R/A)

4. Pull the stiffener tubes and chemical tubing forward and out of the compartment. Make sure the tubing is not tangled or kinked.
5. Insert the stiffener tube and pick-up tubing into its container and stow the supply containers in the lower compartment as shown to the right.

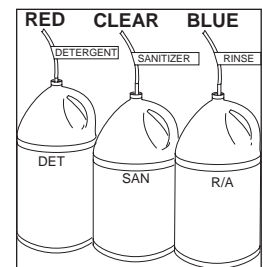
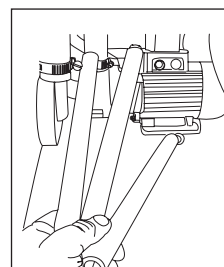
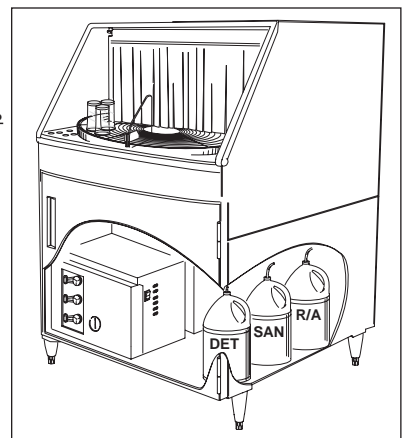

Priming the Chemical Injectors and Approximate Chemical Settings

Each chemical injector can be adjusted using its prime button and concentration adjusting screw. These controls are located on the right side of the control box located in the lower compartment of the glasswasher. The white injector rotors are visible through the control box window.

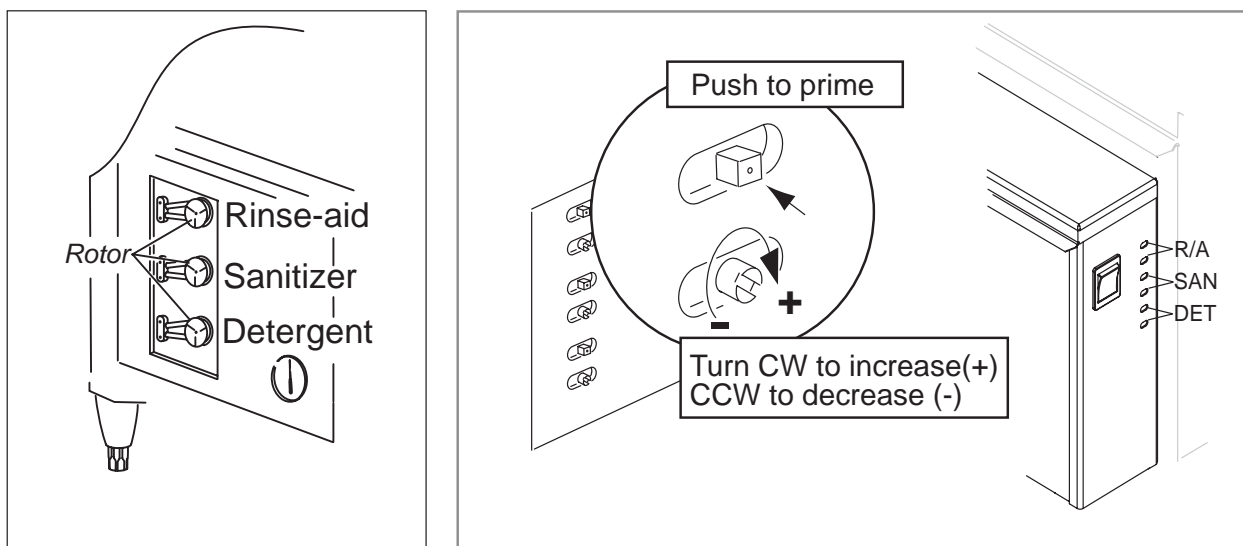

Chemical Injector Prime and Concentration Controls



NOTE:

All of the chemical settings below are approximations.

Consult a qualified chemical representative trained in the use of the test equipments required for taking samples and performing adjustments.

1. Priming the Pumps:

Make sure the proper chemical pick-up tube is in its supply container, then push and hold the prime button until the detergent, sanitizer and rinse-aid feed tubes are full of chemicals. Release the Prime button.

2. Approximate Chemical Settings:

The approximate chemical volume dispensed by the chemical injectors can be determined by counting the number of revolutions of the injector rotor.

Detergent - 1 revolution in 1-second of the detergent pump rotor ~ 0.35% concentration.

Sanitizer - 1 revolution in 5-seconds ~ 12.5 ppm of Iodophor or 50 ppm of chlorine.

Rinse-aid - 1 revolution in 8-seconds ~ the median volume recommended.

Turn the Injector Concentration screws clockwise to increase or counter-clockwise to decrease the volume of dispensed chemical.

- The detergent chemical setting must be performed when the hot-water fill solenoid valve is open. The hot-water valve is open when the power switch is in the ON position during initial fill and when the detergent tank float assembly calls for hot water

The sanitizer and the rinse-aid setting can be performed whenever the cold-water fill solenoid valve is open. The cold-water fill valve is open whenever the glasswasher power switch is ON and the conveyor is turning. A separate rinse-aid is not needed when Iodophor is used as a sanitizer. Turn the Injector Concentration Screw fully counter-clockwise until the rinse-aid injector rotor stops turning.

Flow Diagram

The diagram below shows the major components of the CGM7.5 glasswasher and the flow of water and chemicals during normal operation.

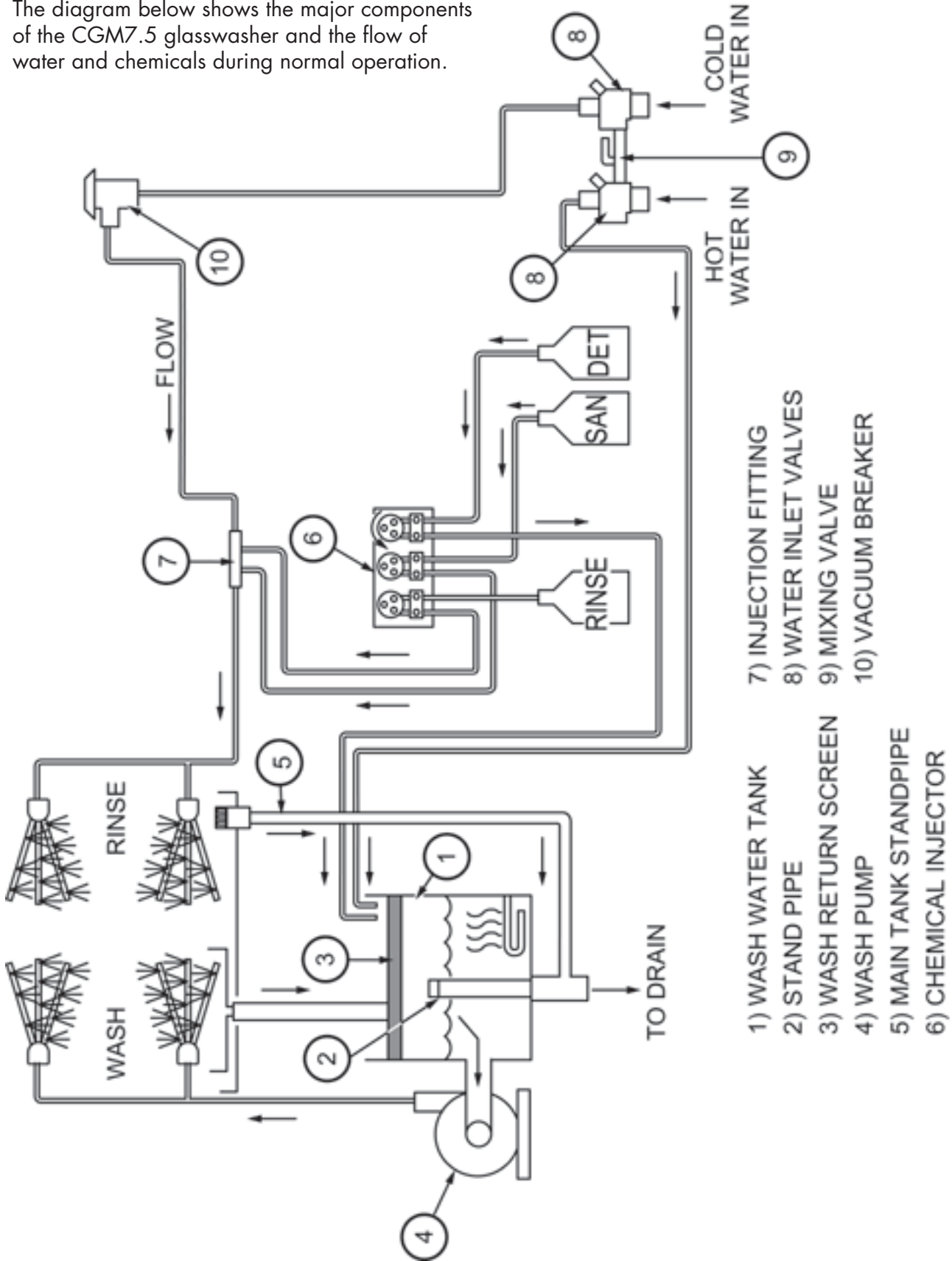

Quick Operation Guide

The glass washing machine is designed to automatically wash a wide variety of glassware.

The glass washer consists of a wash section and rinse section. Glasses rotate on a conveyor through each section. A wash tank in the lower compartment holds heated wash water. The water level in the wash tank is maintained by a float and cam-operated switch. The wash tank water temperature is controlled by a heater and a thermostat. The rinse water is supplied from the cold water supply. Chemicals are automatically dispensed by built-in chemical pumps

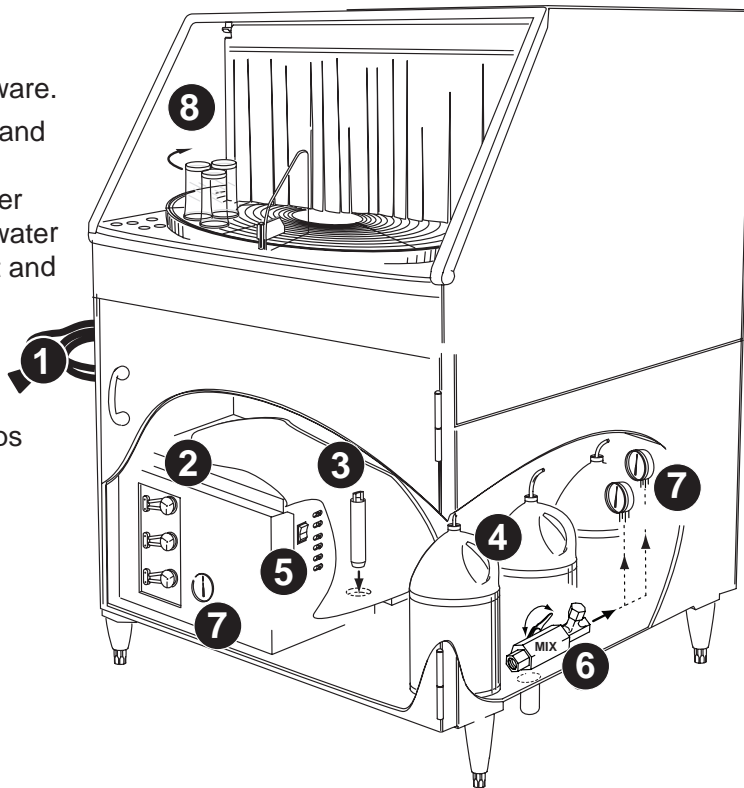

1

Plug machine power cord into a 208-230VAC/60/1.15A wall receptacle. Turn main power and water service ON.

2

Remove lower wash tank scrap screen.

3

Install the drain/overflow tube into the drain located at the front of the wash tank bottom. Re-install the scrap screen removed in Step 2.

4

Pull the chemical pick-up tubes out of the machine. Colored labels I.D. each tube. Place tube into its supply container.

5

Make sure a glass is against the conveyor stop switch, Push the rocker switch UP to the ON position until the wash tank is full of water.

Then, push and hold each chemical Prime button until chemical supply tubes are full.

On
Off
Flush

Prime R/A
Prime Sani
Prime Det.

6

The incoming cold water supply temperature must be a minimum temperature of 75°F/24°C. Adjust the temperature of the incoming cold water temperature by opening or closing the mixing valve located between the hot water and the cold water solenoid valves.

7

Check the cold water temperature gauge and the cold water pressure gauge as you adjust the mixing valve. The minimum temperature should be 75°F/24°C. The pressure gauge should read a flowing pressure of 4-6 psi/24-36 kPa. Check the wash tank temperature gauge for 140°F/60°C-160°F/71°C.

Pressure
Temperature
Wash Tank Heat

8

Place glassware on the conveyor. The conveyor stops automatically when the clean glassware operates the conveyor stop switch.

Operation

Assembling the Glasswasher

1. Make sure the power switch is in the OFF position.
2. Install the wash arms and rinse spray arms. The spray arms have locating notches in the end of each arm. Push the spray arm straight into the hub. Do not twist.
3. Install the conveyor assembly as follows:
 - Insert the conveyor into the wash chamber keeping the rear raised.
 - Pull the conveyor forward until it meshes with the drive gear located at the front of the wash chamber.
 - Continue to pull the conveyor forwards as you lower it on the pivot.
4. Install the stainless steel cylinder in the center of the conveyor.
5. Install the conveyor shut-off assembly (plexiglass divider).
6. Install the right and left hand tray.
7. Install the curtain assembly.
8. Install the upper and lower scrap screens.
9. Install the standpipe in the detergent tank.
 - Twist slightly to make sure it seats securely in the drain.
10. Install the drain tray/waste collector (if equipped).
 - Make sure the drain fitting is secure.
11. Make sure the chemical supply containers are full.
12. Close the door.

Filling the Wash Tank

1. Ensure that the overflow/drain tube is in place in the detergent tank.
2. Flip power on-off/flush switch to the "ON" position. The water will fill until the proper water level is reached.
3. The water temperature is controlled by a tank heater and an adjustable thermostat. The thermostat should be set for a minimum of 140°F/60°C.

Operating Instructions

1. Ensure that the chemical supply containers are full.
2. Detergent is fed into the tank in controlled amounts by the detergent dispensing pump. Use detergent at a strength recommended to you by your chemical supplier.
3. Open the front door and flip the on-off/flush switch to the "ON" position. The detergent tank will fill automatically.
4. Load glasses on the conveyor. The conveyor will stop when the glasses contact the conveyor shut-off switch.

Cleaning Instructions



NOTE:

The cleaning instructions are attached to the inside of glasswasher front door.

Daily Cleaning or after 8 hours of Operation:

1. Make sure that any glasses on the conveyor are clean, then remove them from the conveyor.
2. Push the on-off/flush switch on the right-hand side of the glasswasher control box to the "OFF" position.
3. Remove the splash curtain from the curtain hooks located at each end of the splash curtain rod.
4. Remove the (2) stainless steel conveyor guards located at each corner of the glasswasher and the plexiglass stop assembly.
5. Remove the cylindrical stainless steel conveyor guard located in the center of the glasswasher.
6. Remove the conveyor by lifting the rear of the conveyor while pulling it forward to disengage the conveyor drive gear located at the right front corner of the wash chamber.
7. Take these parts to a sink and wash in hot soapy water using a soft brush and cloth, then rinse with fresh water and set aside to air dry.



DO NOT:

Do not clean with harsh detergents or abrasive scouring pads.
Do not strike the conveyor on the floor or any hard surface.
Do not strike screens on hard surfaces.

8. Clean the wash chamber interior with hot soapy water, then rinse with fresh water. Wipe the interior with a soft cloth. Allow the wash chamber to air dry overnight.
9. Remove the upper scrap screen, remove large debris in a trash can, take screen to a sink, and flush screen with fresh water.



DO NOT:

Do not leave water in the glasswasher overnight.

10. Remove the lower scrap screen, remove large debris in a trash can, take screen to a sink and flush screen with fresh water.
11. Remove the stainless steel wash tank cover; clean with hot soapy water at the wash sink. Wipe clean and dry.
12. Remove the detergent wash tank drain/overflow to drain the tank, then flush the tank with fresh water and wipe with a clean cloth.
13. Reassemble the glasswasher in reverse order for continued operation, or leave disassembled overnight to aid drying.

Continued on the next page.

Cleaning Instructions (continued)

Weekly Cleaning, after 7 days or 56 hours of Operation

1. Complete 1-11 in the Daily Cleaning section on the previous page.
2. Remove chemical supply containers if they are stowed inside the glasswasher, wipe any chemical spills with a damp cloth. Detergent and sanitizer (Chlorine) are corrosive on metal and must be removed as much as possible.
3. Check the inlet chute on the right side of the detergent tank and flush with fresh warm water to clean any chemical residue.
4. Check chemical supply lines. If a line is restricted, remove the pick-up tube from the container, then insert it into a separate container filled with fresh warm water.
5. PUSH and HOLD the PRIME BUTTON labeled for the matching chemical tube until the water moves freely through the supply tubing. Repeat for each chemical making sure that the warm water is fresh and free of any other chemical.
6. Return the pick-up tubes to the chemical container matching the label on the supply tube, then PUSH and HOLD the PRIME BUTTON for the corresponding chemicals until the chemical moves freely through the supply tube.
7. Inspect the chemical dispensing pumps visible behind the plexiglass window located on the front of the control box.
8. Find the spray tube assemblies, (3 spray tubes each) located in the wash chamber. There are (2) assemblies in the top and (2) assemblies in the bottom. Pull (1) assembly at a time. Check the black O-ring on the spray tube hub for damage, replace if missing.
9. Insert and twist the small brass drill bit (reamer) in each spray tube hole to clean. Insert and twist the large drill on the wood handle. Push the large reamer down the length of the spray tubes. Insert and twist the long brush in each spray tube to remove loose debris. Flush the spray tube assembly, then reinstall in the glasswasher. Repeat for each spray tube assembly.
10. Reassemble the glasswasher in reverse order for continued operation, or leave disassembled overnight to aid drying.

***This Page
Intentionally
Left Blank***

Troubleshooting

The following troubleshooting guide can help identify a problem and provide a solution. Inspect your glasswasher before you contact an authorized service representative.

Problem	Cause(s)	Solution(s)
Glasswasher will not turn ON.	<p>Main breaker/fuse box is OFF.</p> <p>Disconnect fuse blown/breaker tripped.</p> <p>Glasswasher ON/OFF switch OFF. Power cord unplugged.</p> <p>Clean glass(es) touching the conveyor shut-off switch.</p>	<p>Turn breaker/fuse box ON.</p> <p>Turn breaker/fuse box ON. Replace fuse/reset breaker.</p> <p>Flip ON/OFF switch ON. Plug-in power cord.</p> <p>Remove clean glasses from the rinse-side of the glasswasher.</p>
Conveyor will not rotate.	<p>Conveyor center hub out of position.</p> <p>Conveyor support(s) out of position and/or broken.</p> <p>Drive gear out of position.</p> <p>Gear teeth on conveyor worn or broken.</p> <p>Gear teeth on drive gear worn or broken.</p> <p>Object jamming the conveyor.</p>	<p>Reposition the conveyor.</p> <p>Reposition or replace support(s).</p> <p>Reposition drive gear.</p> <p>Replace the conveyor.</p> <p>Replace drive gear.</p> <p>Remove object.</p>
Conveyor will not stop rotating.	<p>Conveyor drive motor defective.</p> <p>Conveyor stop switch needs adjustment or switch is defective.</p>	<p>Authorized Service Agent may replace conveyor drive motor.</p> <p>Authorized Service Agent may adjust or replace switch.</p>
Conveyor rotates in wrong direction.	<p>The drive motor is turning the conveyor backward.</p>	<p>Authorized Service Agent may remove drive motor and rotate motor stator 180° and re-install.</p>
Upper scrap screen is hard to remove.	<p>Large debris, such as broken glass, is on screen.</p> <p>Scrap screen bent and/or broken.</p> <p>Door magnet broken or missing.</p>	<p>Remove conveyor and lower spray arm(s). Remove debris.</p> <p>Authorized Service Agent may repair or replace damaged screen.</p> <p>Replace door magnet.</p>
Front door will not close or remain closed.	<p>Door bent or broken.</p>	<p>Straighten or replace door.</p>
Glasswasher not level or rocks back and forth.	<p>Leg(s) are not screwed firmly into machine base.</p>	<p>Tighten leg(s) or replace.</p>

Problem	Cause(s)	Solution(s)
<p>Water sprays out the front of the glasswasher.</p>	<p>Splash curtain is missing, positioned incorrectly, or damaged.</p> <p>Spray arm(s) are damaged or missing.</p> <p>Glass(es) interferes with splash curtain.</p> <p>Clogged spray arm(s) makes water come out in wrong direction.</p>	<p>Re-install the splash curtain or replace the splash curtain.</p> <p>Replace spray arm(s).</p> <p>Reload glass(es).</p> <p>Clean the spray arm(s).</p>
<p>Poor washing results.</p>	<p>Water volume from wash and/or rinse spray arm(s) low.</p> <p>Water level in detergent tank low.</p> <p>Water level float ball stuck or filling with water.</p> <p>Water level switch defective.</p> <p>Detergent and/or rinse-aid supply low.</p> <p>Wash pump and/or water valve(s) and/or line strainers clogged or defective.</p> <p>Detergent tank temperature low.</p> <p>Chemical injectors out of adjustment.</p>	<p>Clean spray arm(s).</p> <p>Re-install drain/overflow tube in wash tank. Service Agent must adjust water level switch until water level is below top of overflow.</p> <p>Clean float ball, replace if filling with water.</p> <p>Authorized Service Agent may replace switch.</p> <p>Refill chemical supplies.</p> <p>Authorized Service Agent may replace wash pump and/or solenoid valve(s). Clean line strainers.</p> <p>Raise incoming water temperature or adjust thermostat for 140°F/60°C in detergent tank.</p> <p>Contact chemical supplier to calibrate settings.</p>
<p>Chemical supply container(s) fill with water.</p>	<p>Peristaltic tube(s) are stretched or worn on the glasswasher chemical pumps.</p> <p>Flow control washer in cold water solenoid valve is defective.</p>	<p>Inspect and replace tube(s).</p> <p>Contact Service Agent to repair solenoid valve.</p>

Troubleshooting

Problem	Cause(s)	Solution(s)
Water temperature below 145°F/66°C in detergent tank.	<p>Detergent tank thermostat temperature setting low.</p> <p>Thermostat is defective.</p> <p>Detergent tank heater is defective.</p> <p>Incoming water temperature is below 140°F/60°C.</p>	<p>Increase thermostat setting to 145°F/66°C.</p> <p>Authorized Service Agent may replace thermostat.</p> <p>Authorized Service Agent may replace detergent tank heater.</p> <p>Raise incoming water temperature to 140°F/66°C</p>
Water leaking under glasswasher.	<p>Pump water seal defective.</p> <p>Glasswasher drain line is clogged.</p> <p>Upper wash compartment drain screen is clogged.</p> <p>Detergent tank drain screen is clogged.</p> <p>Building drain line is clogged.</p> <p>Condensation is forming on the underside of wash compartment.</p> <p>Vacuum breaker at rear of glasswasher leaking.</p>	<p>Authorized Service Agent may replace pump seal.</p> <p>Clean drain line.</p> <p>Clean drain screen.</p> <p>Clean detergent tank drain screen.</p> <p>Clean building drain line.</p> <p>Open rinse water mixing valve until temperature of water is 70°F/21°C.</p> <p>Replace vacuum breaker.</p>

Problem	Cause(s)	Solution(s)
<p>Water flows into glasswasher when ON/OFF switch is in the OFF position.</p>	<p>Flowing water supply line pressure measured at the glasswasher exceeds 95 PSI (655 kPa).</p> <p>Defective solenoid valve(s).</p> <p>Defective AUTO-FILL switch.</p>	<p>Incoming water pressure must be 5 PSI/35 kPa on pressure gauge located on right-side of glasswasher lower compartment.</p> <p>Authorized Service Agent may rebuild or replace solenoid valve(s).</p> <p>Service Agent may replace the switch.</p>
<p>Chemical(s) are not flowing into the glasswasher.</p>	<p>Rinse water pressure too high.</p> <p>Chemical container(s) are empty.</p> <p>Chemical supply line(s) are clogged.</p> <p>Chemical supply and/or pump tube(s) are broken.</p> <p>No power to chemical dispensing pump(s).</p> <p>Dispensing pump is defective.</p> <p>Chemical pumps out of adjustment.</p>	<p>Reduce flowing water pressure measured at the glasswasher below 95 PSI (655 kPa).</p> <p>Refill the container(s).</p> <p>Remove the supply line(s) from the chemical container(s) and flush with warm water.</p> <p>Replace supply line(s) and/or pump tube(s).</p> <p>Authorized Service Agent may replace chemical dispensing pump.</p> <p>Authorized Service Agent must inspect and repair.</p> <p>Chemical supplier must adjust chemical pumps.</p>

***This Page
Intentionally
Left Blank***

Service Replacement Parts

Illustration List	Page
Base Assembly.....	18
Conveyor, Guides, Curtains	20
Wash Hubs, Spray Arms.....	22
Conveyor Stop Switch	24
Drive Motor Assembly.....	26
Vacuum Breaker Assembly	28
Wash Pump and Piping	30
Inlet Plumbing	32
Sanitizer Plumbing.....	34
Detergent Tank Assembly	36
Control Box Assembly.....	38
Options and Accessories.....	40

Base Assembly

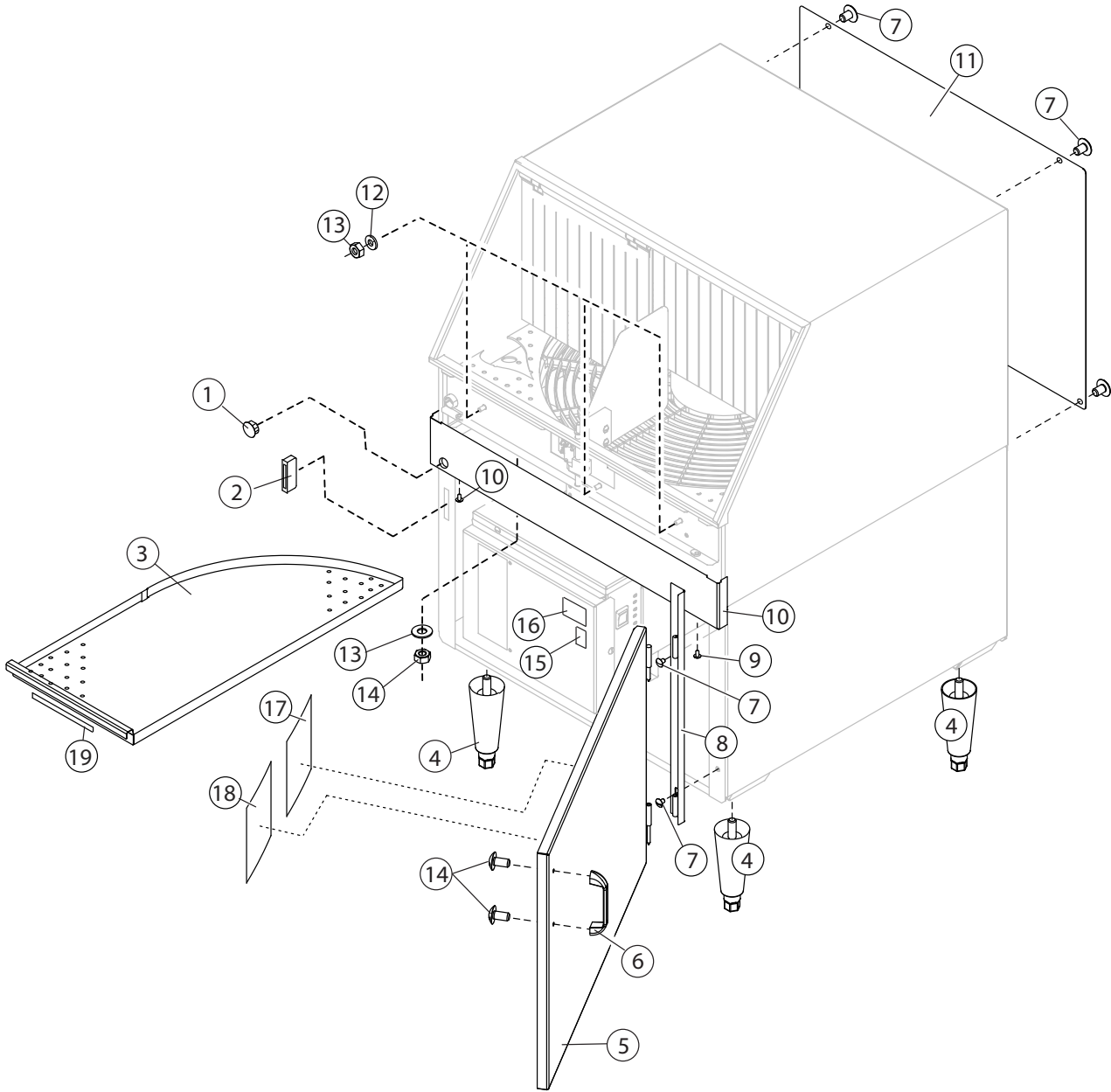

Item No.	Part No.	Description	Qty.
1	112519	PLUG, CAP 1"	1
2	0501885	DOOR CATCH, MAGNETIC	1
3	0713746	SCRAP SCREEN, WASH TANK (Includes Item 19)	1
4	0501873	LEG 6"	4
5	0712643	DOOR ASSY.	1
6	111561	HANDLE, DOOR	1
7	0510884	SCREW, 1/4-20 X 1/2" TRUSS HEAD	10
8	0712647	BRACKET, DOOR	1
9	0501412	SCREW, 10-32 X 3/8"	2
10	0312598	PANEL, FLAT FACIA	1
11	0312601	PANEL, REAR	1
12	0501476	WASHER, FLAT 1/4"	2
13	107967	NUT, 1/4-20 NYLON LOCK	2
14	0501464	SCREW, 10-24 X 3/8"	2
15	0505112	LABEL, DATA PLATE	1
16	0503301	LABEL, WARNING	1
17	0512659	LABEL, CLEANING INSTRUCTIONS	1
18	0514421	LABEL, ELECTRICAL SCHEMATIC	1
19	0507471	LABEL, CLEAN SCREENS DAILY	1

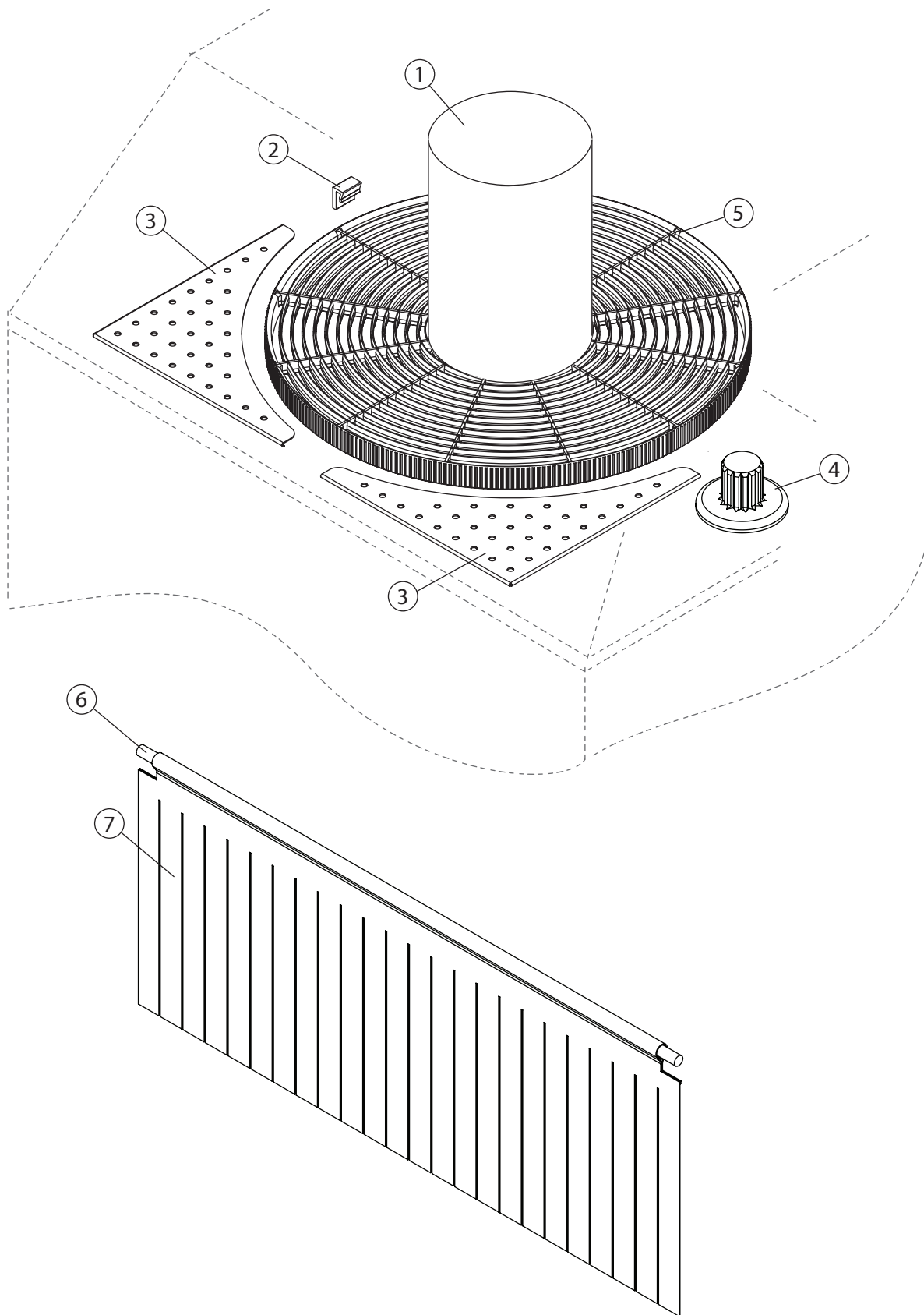

Item No.	Part No.	Description	Qty.
1	0313603	HUB, CONVEYOR	1
2	0312695	BLOCK, CONVEYOR GUIDE	4
3	0312604	TRAY, CONVEYOR	2
4	0506886	GEAR, DRIVE	1
5	0506885	CONVEYOR	1
6	0312610	ROD,CURTAIN, 3/8" D X 24" L	1
7	0512549	CURTAIN	1

Wash Hubs, Spray Arms

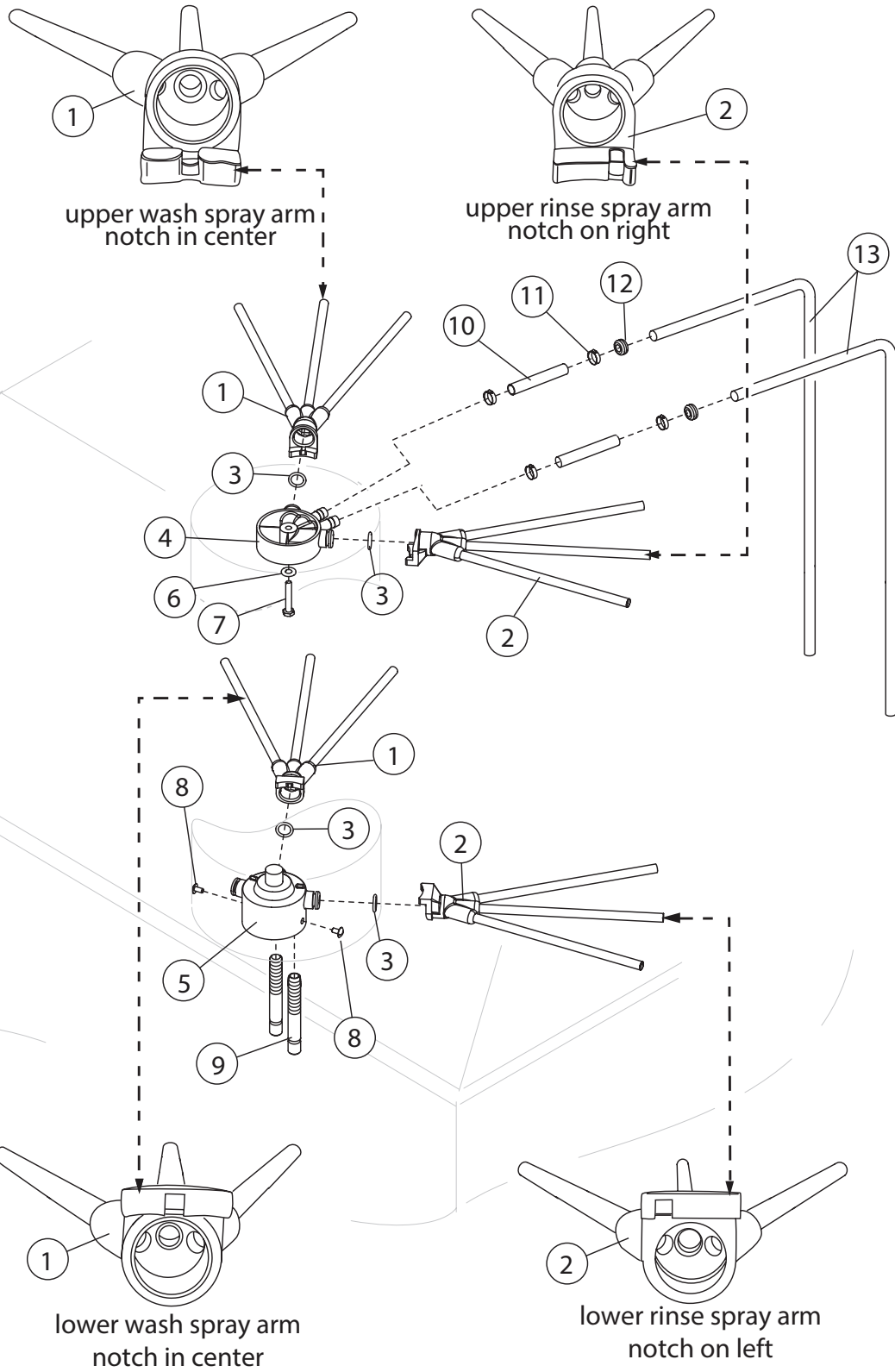

Item No.	Part No.	Description	Qty.
1	0501613	WASH ARM	2
2	0501738	RINSE ARM	2
3	0501608	O-RING	4
4	0501610	TOP MANIFOLD	1
5	0301622	BOTTOM MANIFOLD	1
6	0501476	FLAT WASHER, 1/4"	1
7	0501422	BOLT, 1/4-20 X 1-1/2"	2
8	0501412	SCREW, 10-32 X 3/8"	2
9	0500813	BOTTOM MANIFOLD INLET TUBE	2
10	0502663	BRAIDED HOSE, 3/8"	A/R
11	0503679	GEAR CLAMP #6	4
12	0509478	GROMMET	2
13	0300908	TUBE, RINSE	2

Conveyor Stop Switch

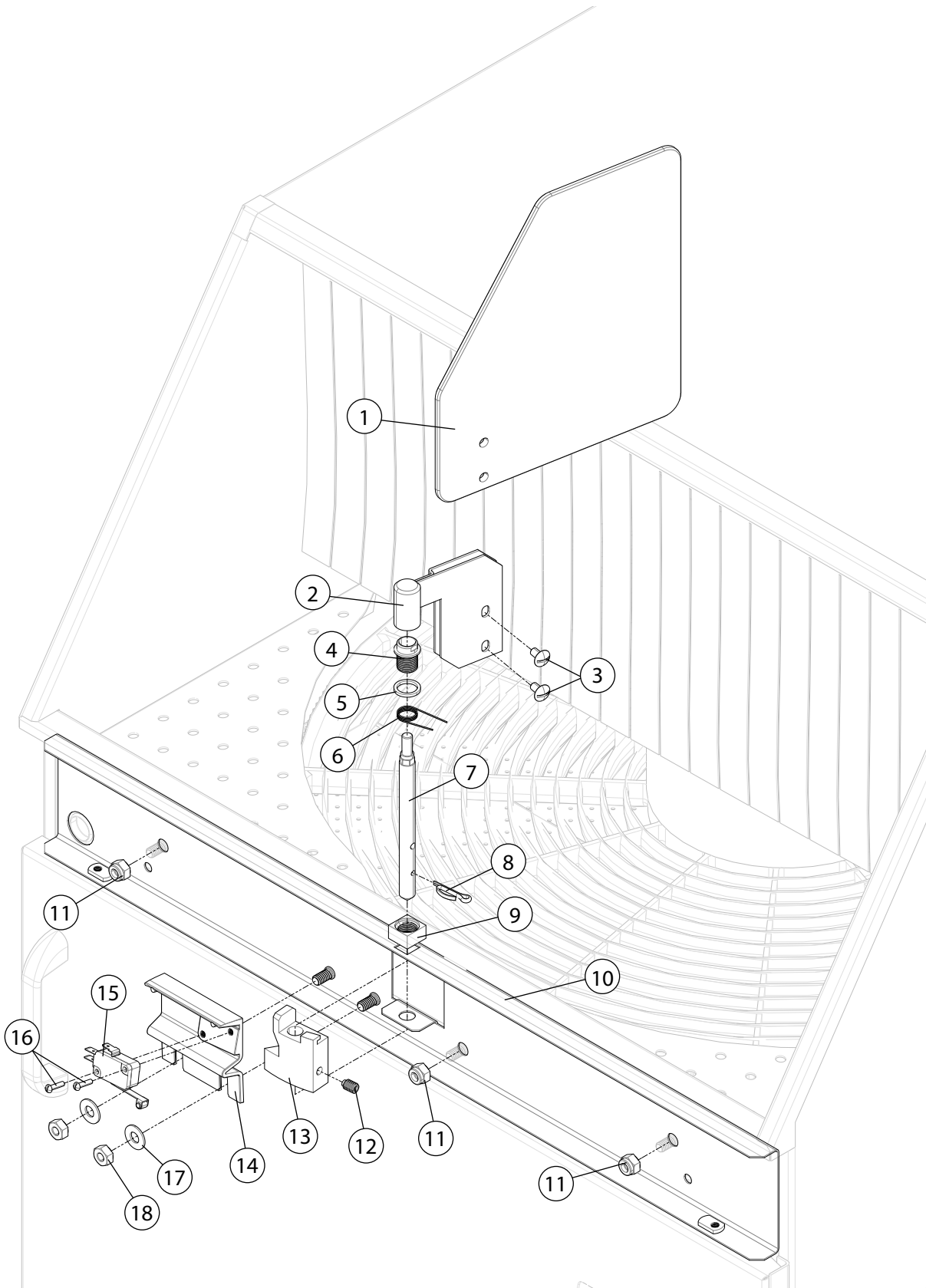

Item No.	Part No.	Description	Qty.
1	0512556	PLATE, DIVIDER	1
2	0713771	SHUT-OFF ARM ASSY.	1
3	0501412	SCREW 10-32 X 3/8"	2
4	0513768	BUSHING, SHAFT SHUT-OFF ARM	1
5	0513775	O-RING	1
6	0512559	SPRING	1
7	0513770	SHAFT, CONVEYOR SHUT-OFF	1
8	106558	PIN, COTTER	1
9	0513769	NUT	1
10	0313773	BRACKET, SHUT-OFF ARM LS	1
—	0313774	BRACKET, SHUT-OFF ARM RS	1
11	107697	NUT, 1/4-20 WITH NYLON INSERT	3
12	0510854	SCREW, DOG-POINT 1/4-20 X 1/2"	1
13	0512557	CONVEYOR SHUT-OFF CAM	1
14	0513789	HOUSING, CONVEYOR SWITCH	1
15	0501379	SWITCH 15A	1
16	0501437	SCREW 4-40 X 1/2"	2
—	0712735	SHUT-OFF ASSEMBLY (INCLUDES ITEMS 1-3)	1

Drive Motor Assembly

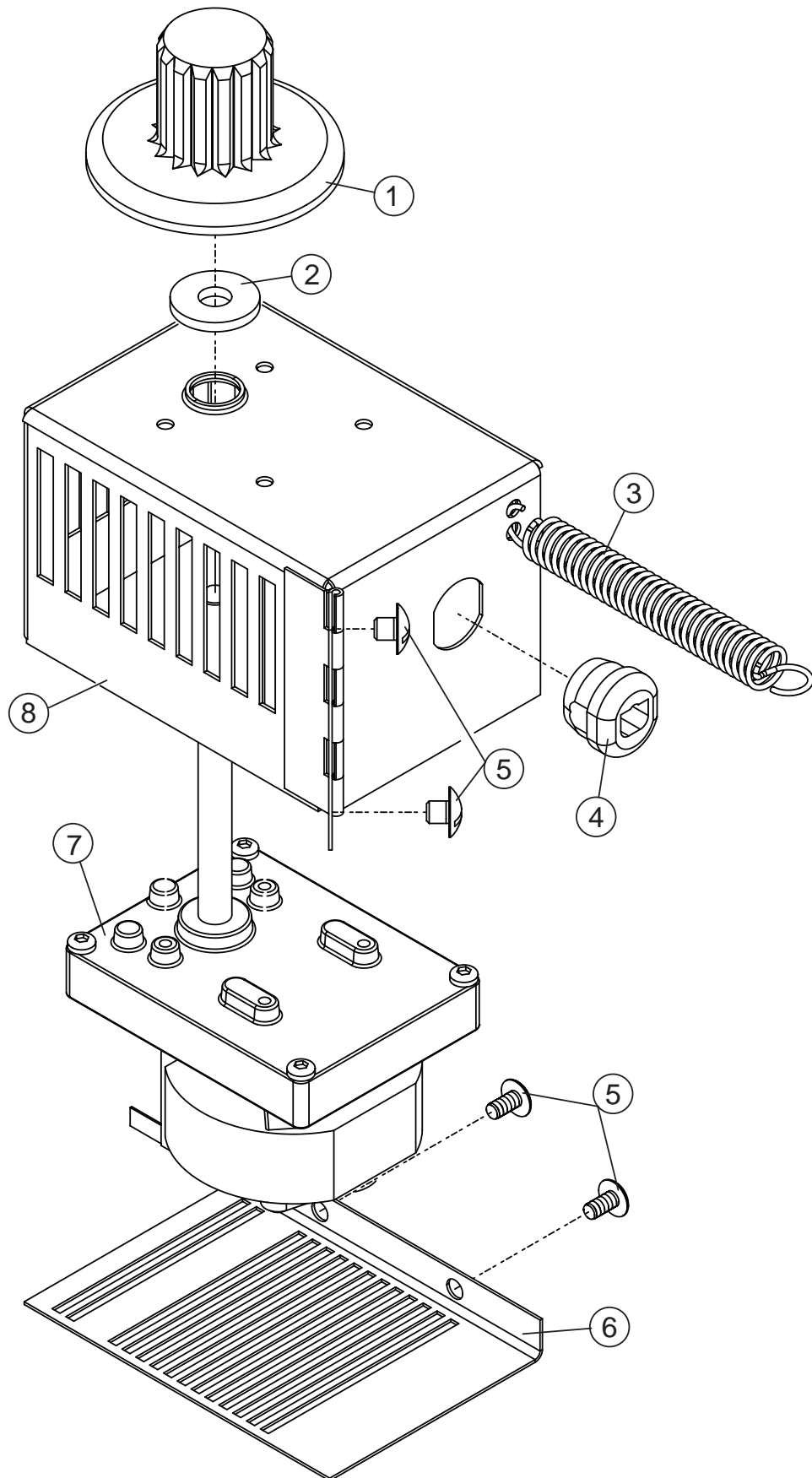

Item No.	Part No.	Description	Qty.
1	0506886	GEAR, DRIVE	1
2	0507264	SLINGER, WATER	1
3	0501923	SPRING, EXTENSION	1
4	0512713	BUSHING, SNAP	1
5	0501412	SCREW 10-32 X 3/8"	4
6	0307617	COVER, DRIVE MOTOR HOUSING	1
7	0512532	MOTOR, DRIVE 230VAC	1
8	0712712	HOUSING, DRIVE MOTOR	1

Vacuum Breaker Assembly

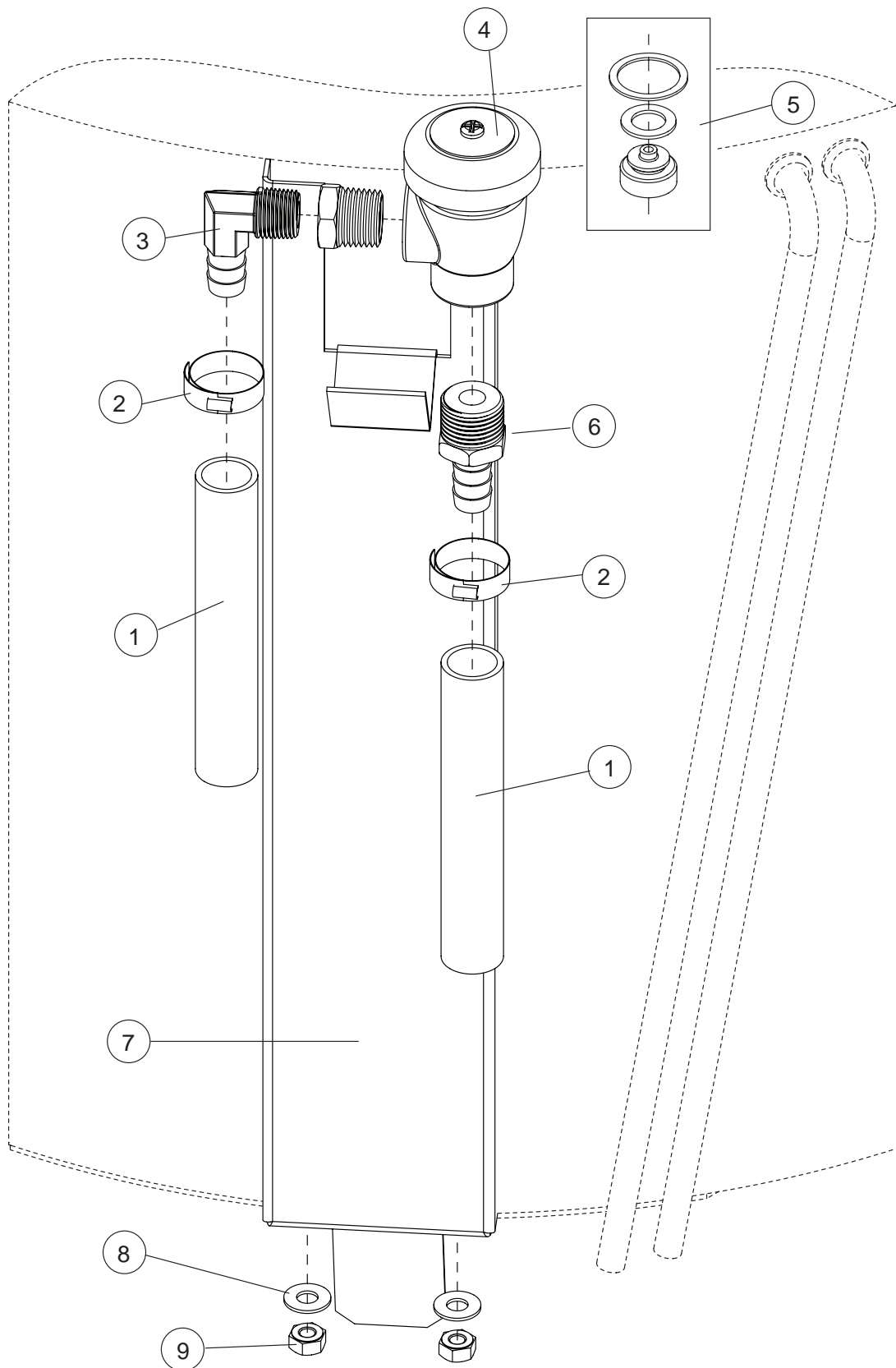

Item No.	Part No.	Description	Qty.
1	0502665	HOSE, 1/2" I.D. BRAIDED	A/R
2	0503679	CLAMP, 7/16" GEAR	2
3	0502653	BARB, HOSE 3/8" MPT X 1/2" 90°	1
4	100500	BREAKER, VACUUM 1/2"	1
5	0508366	KIT, REPAIR VACUUM BREAKER	1
6	0502651	COUPLER, HOSE 1/2" MPT X 1/2"	1
7	0312684	SUPPORT, PLUMBING	1
8	0501476	WASHER, FLAT 1/4"	2
9	107967	NUT, 1/4-20 NYLON LOCK	2

Wash Pump and Piping

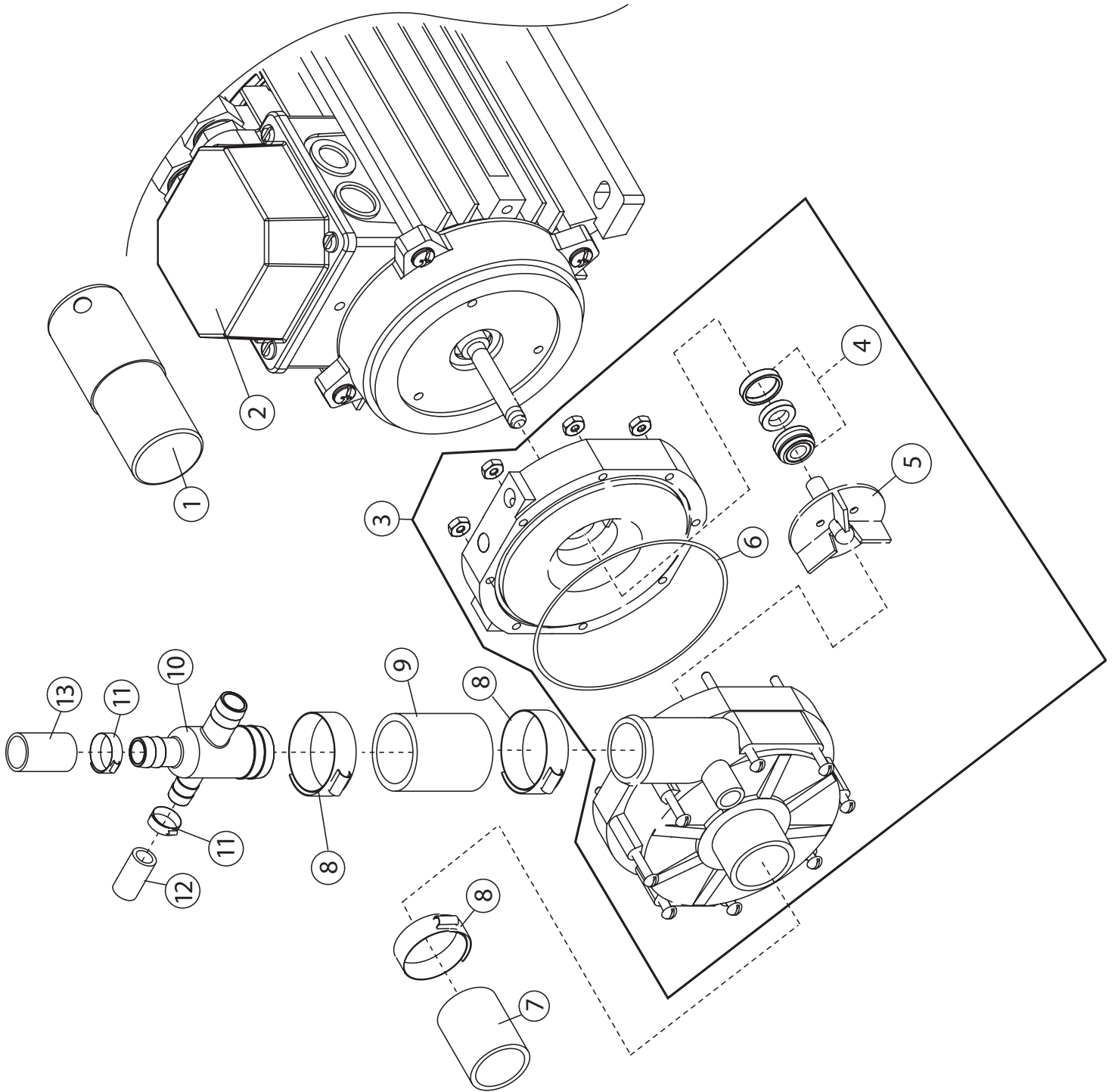

Item No.	Part No.	Description	Qty.
1	0512679	MOTOR CAPACITOR 6.3uF, 370VAC	1
2	0512531	PUMP/MOTOR COMPLETE 230V/50-60Hz/1Ph	1
3	0512678	PUMP KIT (INCLUDES ITEMS 4-6)	1
4	0512677	SEAL, PUMP	1
5	0512680	IMPELLER, PUMP	1
6	0512746	O-RING, WASH PUMP	1
7	0507320	HOSE 1" I.D. X 1-1/4" OD	6
8	0502563	CLAMP ,HOSE #6	A/R
9	0502668	HOSE ,BRAIDED 1" I.D. X 1-3/8" O.D.	6
10	0501632	CONNECTOR, PUMP HOSE	1
11	0503679	CLAMP, HOSE #16	A/R
12	0502665	HOSE, BRAIDED 1/2" I.D. X 3/4" O.D.	A/R
13	0502663	HOSE, BRAIDED 3/8" I.D. X 5/8" O.D.	A/R

**NOTE:**

The pump motor is not available as a separate service replacement part.

Inlet Plumbing

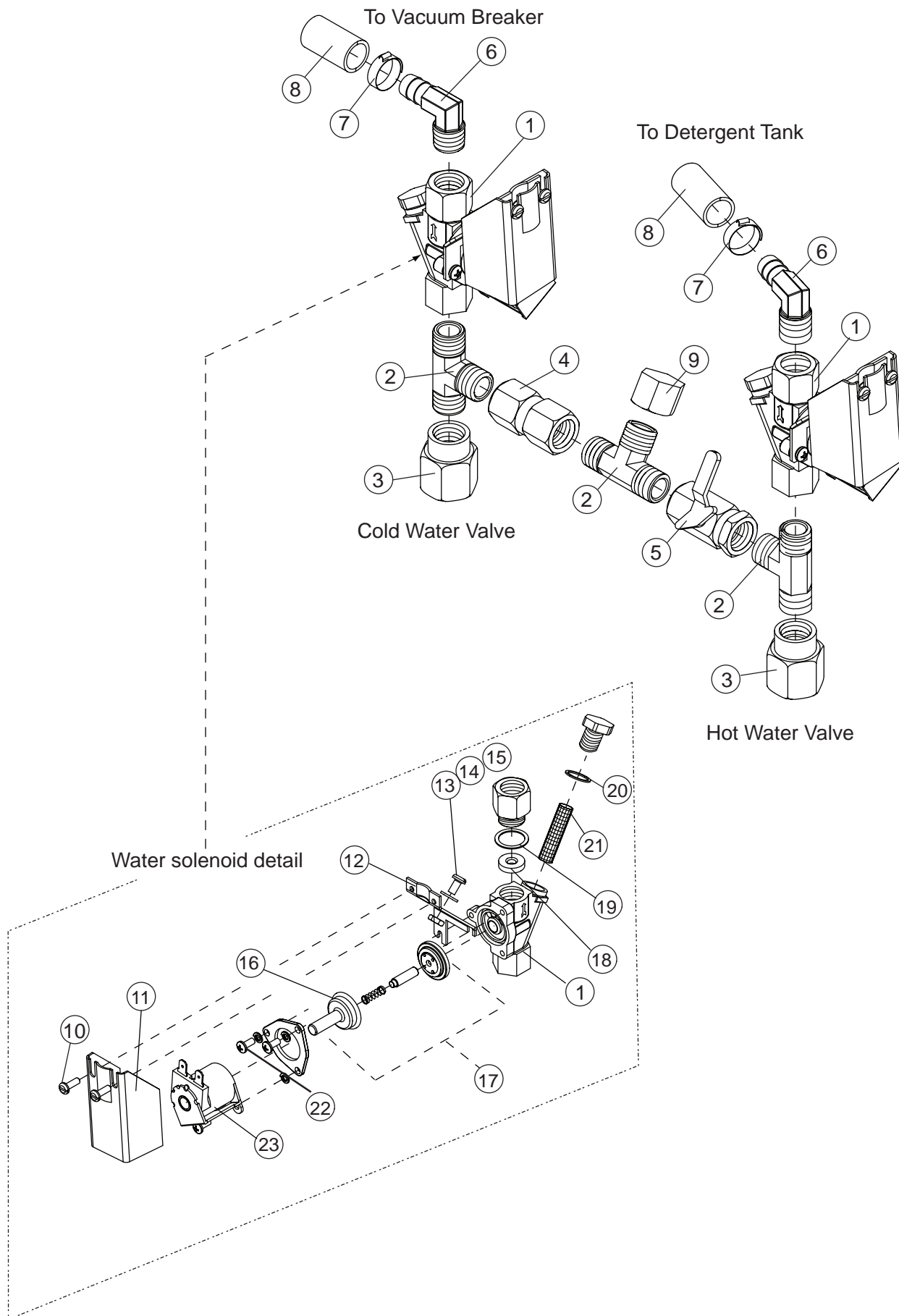

Item No.	Part No.	Description	Qty.
1	0502783	VALVE, SOLENOID 230VAC/60 HZ	2
2	0503802	TEE, 3/8" MPT	3
3	0503801	ADAPTER, 3/8" FEM X 1/2"	1
4	0507324	VALVE, CHECK 3/8"	1
5	0502768	VALVE, STOP	1
6	0502653	BARB, HOSE 3/8" X 1/2' 90°	2
7	0503679	CLAMP, GEAR 7/16"	2
8	0502665	HOSE, BRAIDED 1/2" I.D. X 3/4" O.D.	A/R
9	0509659	CAP	1
10	0504822	SCREW 8-32 X 1/2"	2
11	0306208	COVER, CABLE CLAMP	2
12	0307373	CLAMP, CABLE	2
13	0501404	SCREW 10-32 X 3/8" BRASS	2
14	0501493	WASHER, LOCK #10	2
15	0501533	NUT 10-32 BRASS	2
16	0505229	GUIDE, SOLENOID	1
17	0502811	KIT, DIAPHRAGM	A/R
18	0502810	WASHER, FLOW (2.6 gpm)	1
19	0502807	WASHER, BRASS	1
20	0502804	GASKET, STRAINER CAP	1
21	0502803	SCREEN	1
22	0501406	SCREW 8-32 X 1/2"	2
23	0502806	COIL, SOLENOID VALVE, 230VAC/60	1

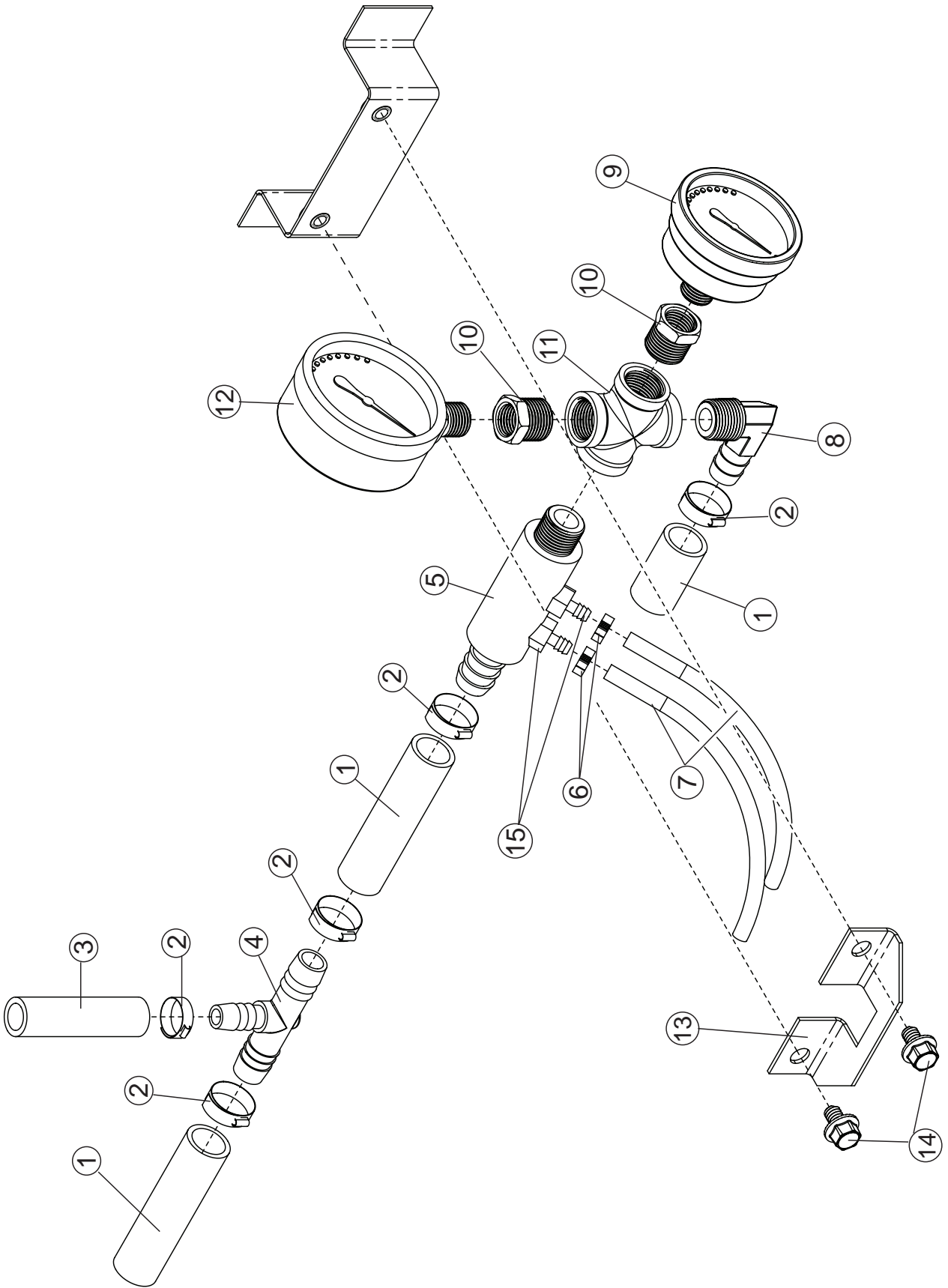

Item No.	Part No.	Description	Qty.
1	0502665	HOSE, BRAIDED 1/2" I.D. X 3/4" O.D.	A/R
2	0503679	CLAMP, GEAR 7/16"	5
3	0502663	HOSE, BRAIDED 3/8" I.D. X 5/8" O.D.	A/R
4	0502652	TEE, 1/2" X 1/2" X 3/8"	1
5	0503669	FITTING, BARB INJECTOR	1
6	0501519	TIE, CABLE 4"	2
7	0502666	TUBING, CHEMICAL 1/8" I.D. X 1/4" OD	A/R
8	0502653	BARB, HOSE 3/8" MPT X 1/2" 90°	1
9	0503668	THERMOMETER	1
10	0502577	BUSHING, REDUCER 3/8" X 1/4"	2
11	0502583	CONNECTOR, CROSS 3/8" FPT	1
12	0507100	GAUGE, PRESSURE 0-30 PSI	1
13	0300918	CLAMP	1
14	0512185	BOLT, 1/4-20 X 3/8"	2
15	0502645	BARB, HOSE 1/8"	2

Detergent Tank Assembly

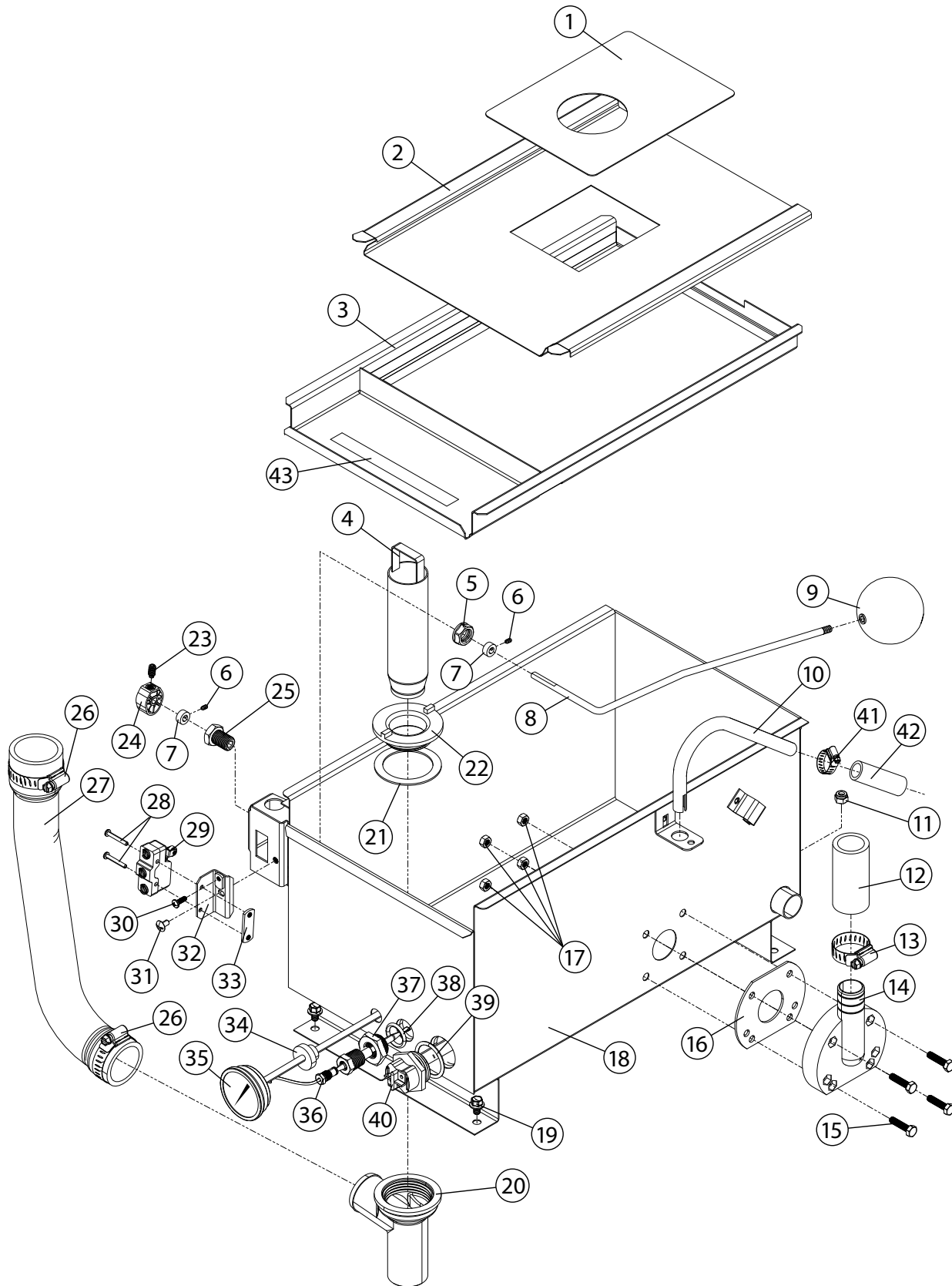

Item No.	Part No.	Description	Qty.
1	0312592	COVER, STEAM	1
2	0312591	COVER, DETERGENT TANK	1
3	0712641	SCREEN, DETERGENT TANK	1
4	0700948	STANDPIPE, DETERGENT TANK	1
5	201669	LOCKNUT, 1/4 NPT, NICKLE PLATE	1
6	0501397	SCREW, SET 6-40 X 3/16" SOCKET SST	2
7	0703673	COLLAR (SET SCREW INCLUDED)	2
8	0512554	ROD, FLOAT	1
9	0503670	BALL, FLOAT	1
10	0307427	TUBE, WATER INLET	1
11	107967	NUT, GRIP 1/4-20 W/NYLON INSERT	1
12	0502668	HOSE, PVC 1" I.D. X 1-3/8" OD	6"
13	0502563	CLAMP, GEAR 1"	1
14	108051	FLANGE, ELBOW	1
15	0507431	BOLT M6 X 25MM (METRIC)	4
16	107886	GASKET, INLET CHUTE	1
17	107435	NUT, M6 (METRIC)	4
18	0712640	TANK, DETERGENT	1
19	0512185	BOLT, HEX FLANGE 1/4-20 X 3/8" SST	2
20	0512534	TEE, MOLDED DRAIN	1
21	0512536	GASKET, DRAIN	1
22	0512535	DRAIN SEAT, MOLDED	1
23	0501395	SCREW, SET 1/4-20 X 5/16" SST	1
24	0312682	CAM, FLOAT	1
25	0512550	BUSHING, FLOAT ROD	1
26	0502571	CLAMP, HOSE 1-1/2"	2
27	0512533	HOSE, MOLDED DRAIN	1
28	0503723	SCREW, 6/32 X 1"	2
29	0501375	SWITCH, TRIP C/W ROLLER	1
30	0514175	SCREW, NYLOCK 9-32 X 3/8" SST	2
31	0501412	SCREW. 10-32 X 3/8" TRUSS HD. PHIL. SST	1
32	0314416	BRACKET, FLOAT SWITCH	1
33	0502977	WELDNUT, DUAL 6/32 NICKEL PLATED	1
34	0501896	SEAL, THERMOMETER	1
35	0501600	THERMOMETER, 8" STEM	1
36	0507323	THERMOSTAT	1
37	0501650	ADAPTER, THERMOSTAT	1
38	0501836	O-RING	1
39	0503588	O-RING, HEATER (Comes with Item 40)	1
40	0507315	HEATER, DETERGENT TANK 3kW (Includes Item 39)	1
41	0503679	CLAMP, HOSE #6	1
42	0502665	HOSE, BRAIDED 1/2"	A/R
43	0507471	LABEL, CLEAN SCREENS DAILY	1

Control Box Assembly

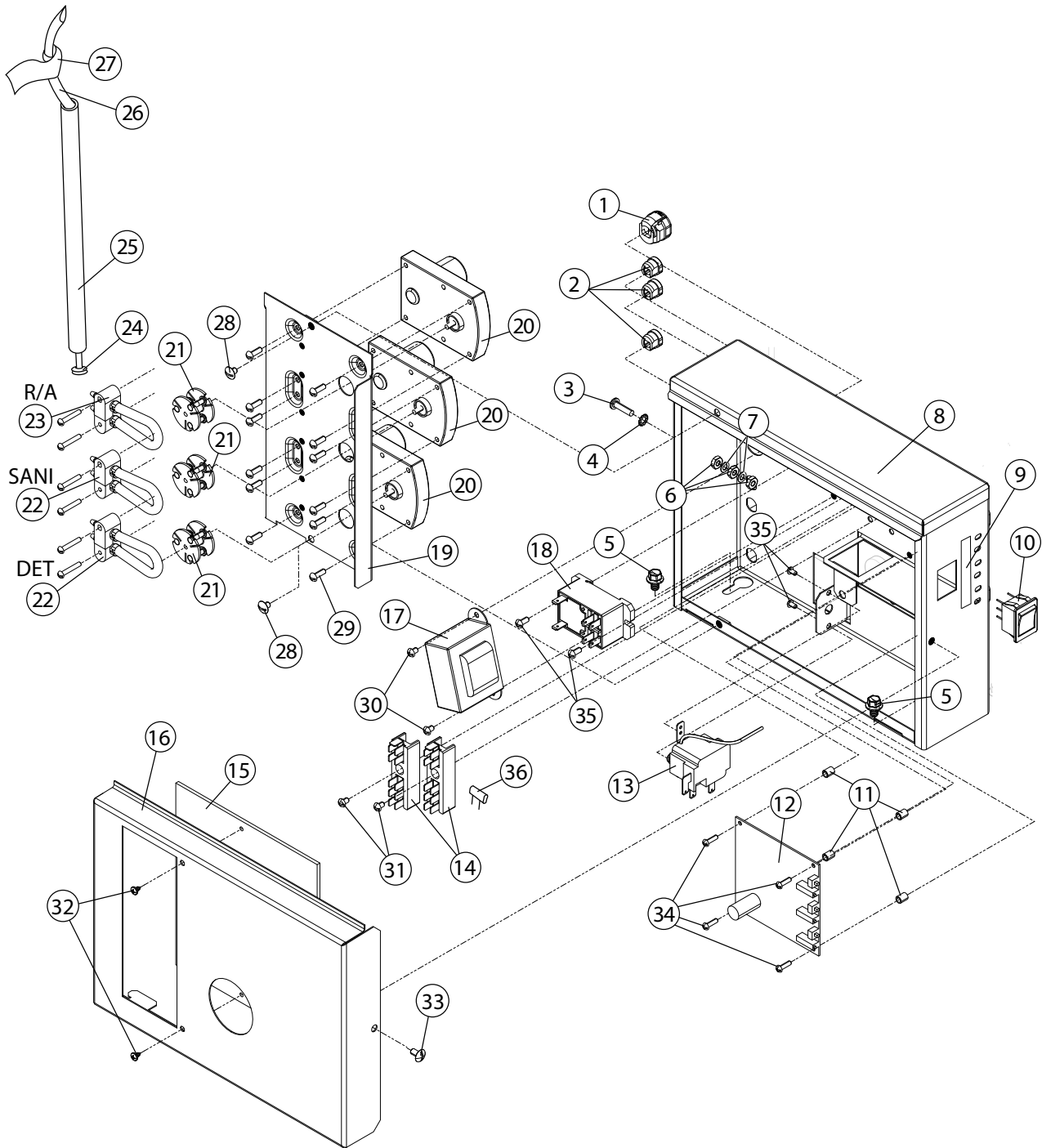

Item No.	Part No.	Description	Qty.
1	0503647	STRAIN RELIEF BUSHING (LARGE)	1
2	0512713	STRAIN RELIEF BUSHING (1/2")	3
3	0501404	SCREW, 10-32 X 3/8" ROUND HEAD, BRASS	1
4	0501493	WASHER, LOCK #10 EXT. TOOTH BRASS	1
5	0512185	BOLT, HEX FLANGE 1/4-20 X 3/8" SST	2
6	0501533	NUT, 10-32 BRASS	3
7	0501472	WASHER, FLAT, #10 BRASS	2
8	0314412	BOX, CONTROL	1
9	0512663	LABEL, PRIME	1
10	0512539	SWITCH, ROCKER, ON/OFF/FLUSH	1
11	0508710	SPACER, CONTROL BOARD	4
12	0508433	CIRCUIT BOARD, MOTOR CONTROL	1
13	0507323	THERMOSTAT, CONTROL	1
14	0503749	BOARD, TERMINAL 1 1 PT	2
15	0312590	WINDOW, CONTROL BOX COVER	1
16	0312589	COVER, CONTROL BOX	1
17	0508920	TRANSFORMER, 240VAC/18VAC, 30VA	1
18	0514162	RELAY, DPST 30A, 240VAC, 240VAC COIL	1
19	0312588	PANEL, CHEMICAL PUMP	1
20	0501353	MOTOR, INJECTOR 140 RPM, 24VDC	3
21	0707142	ROTOR, INJECTOR	3
22	0706635	TUBE, ELEMENT 45cc (DETERGENT, SANITIZER)	2
23	0706634	TUBE, ELEMENT ASSY 15cc (RINSE-AID)	1
24	0501869	STRAINER	3
25	0306363	TUBE, STIFFENER	3
26	0502666	TUBING, CHEMICAL 1/8" I.D. X 1/4" O.D.	A/R
27	0503695	LABEL, DETERGENT	1
—	0503694	LABEL, SANITIZER	1
—	0505483	LABEL, RINSE-AID	1
28	0504822	SCREW, 8-32 X 1/2" PAN HD. PHIL. SST	12
29	0501411	SCREW, 10-32 X 1/4"	12
30	0501408	SCREW, 8-32 X 1/4" TRUSS HD. PHIL. SST	2
31	0503648	SCREW, 8-32 X 3/8" PAN HD. SST	2
32	0504823	RIVOT, POP 1/8" ALUMINUM	2
33	0504411	SCREW, 10-32 X 1/4" RD. HD. PHIL. SST	1
34	106695	SCREW, 6-32 X 1/2" ROUND HD. PHIL.	4
35	0501450	SCREW, NIBS RH 6-32 X 3/16" PHIL. SST	2
36	0713778	SNUBBER COMES W/FASTONS	1
—	0512538-1	HARNESS, WIRING (NOT SHOWN)	1

Options And Accessories

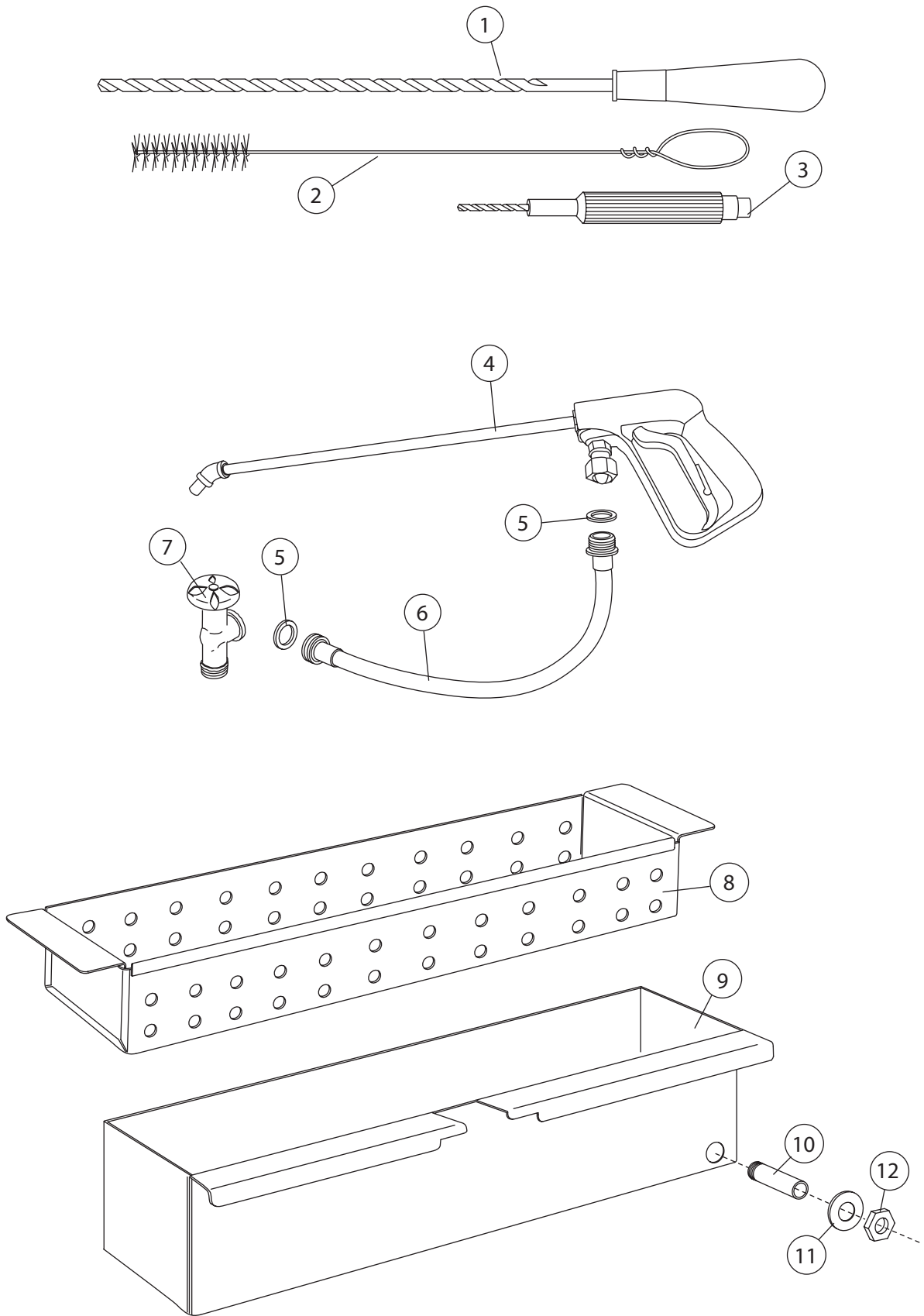

Options and Accessories

Item No.	Part No.	Description	Qty.
1	0708986	TUBE SCRAPER	1
2	0501826	TUBE BRUSH	1
3	0501633	JET REAMER (COMES WITH DRILL)	1

Item No.	Part No.	Description	Qty.
4	0510571	NOZZLE, WASHDOWN	1
5	0505320	1/2" HOSE WASHER	1
6	0501833	1/2" X 10' HOSE ASSY.	1
7	0506643	FAUCET	1
—	0503801	ADAPTER, 3/8" FEM X 1/2" FEM (NOT SHOWN)	1
—	0701956	WASH DOWN HOSE KIT (Includes items 4-8)	1

Item No.	Part No.	Description	Qty.
8	0512719	SCREEN, DRAIN TRAY	1
9	0512717	TRAY, DRAIN	1
10	0512943	TUBE, DRAIN	1
11	0512688	GROMMET	1
12	0512946	NUT, 5/8-20 BULKHEAD, POLY.	1
—	0712551	DRAIN TRAY AND WASTE COLLECTOR KIT (Includes items 8-12)	1

Electrical Schematic

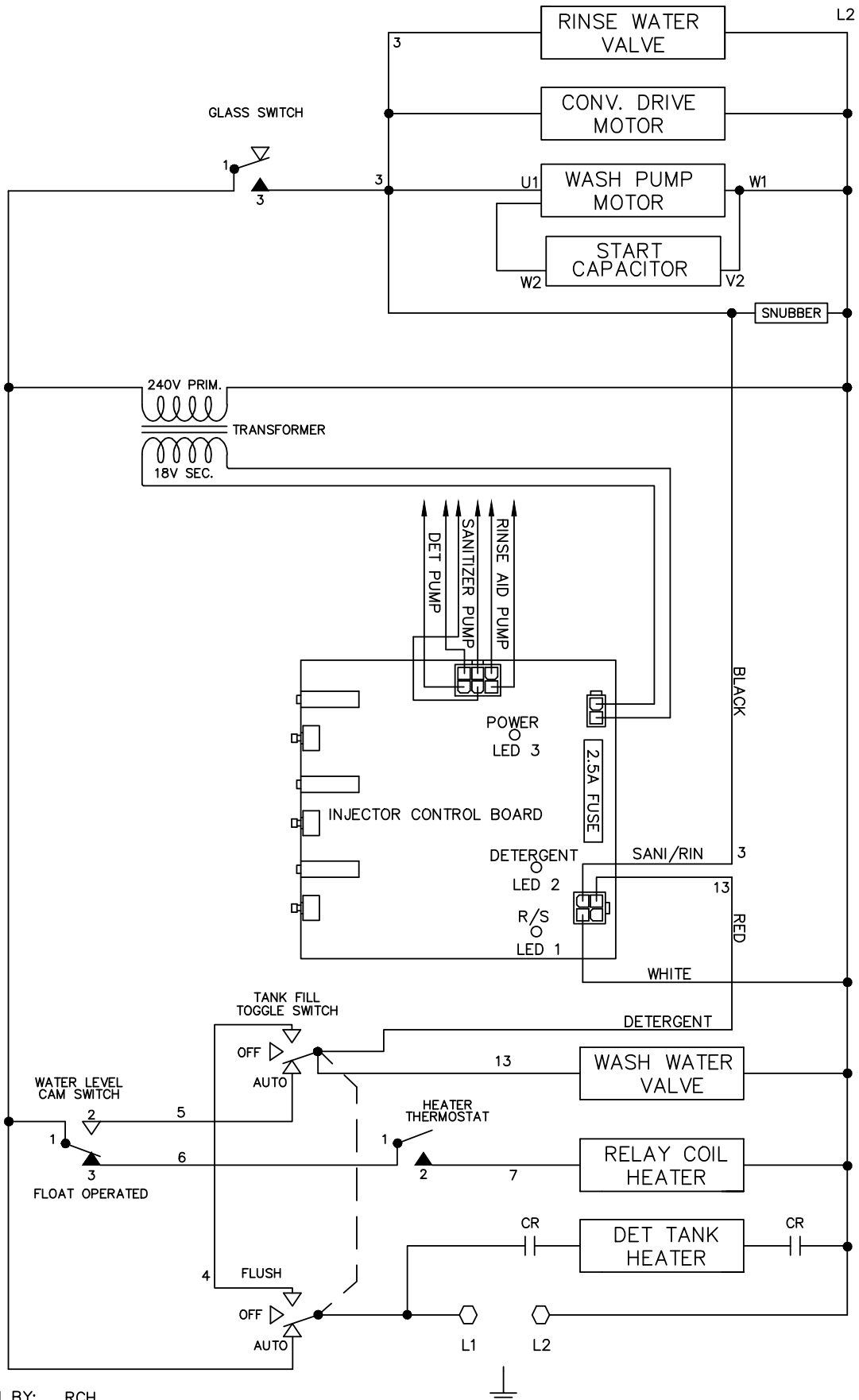

DRAWN BY: RCH
 CHECKED BY: RAH
 DATE JAN 2016

208/230V 13A 60HZ SINGLE PHASE

DF/CG M7.5
 0514421 REV A