

Champion[®]

The Dishwashing Machine Specialists

PROJECT: _____

ITEM # _____ QTY: _____

MODEL # _____

AIA # _____ SIS # _____

44 PRO w/ Heat Recovery Steam

HIGH TEMPERATURE STEAM RACK CONVEYOR



Rendered image is for general visual representation only. Please refer to specifications for the latest detailed product information.

Customers save \$1500 per year in energy cost on average when compared to a standard machine!



STANDARD FEATURES

- **Exhaust Air Energy Recovery**
reuses waste energy to preheat incoming water
- **Perpetual Rack Advance System**
with digital jam monitoring, and mechanical drive protection
- **Automated Delime Function**
with user-customizable alert intervals
- **209 Racks Per Hour**
- **0.48 Gallons/Rack With Energy Sentinel** (idle pump shut-off)
- **Advanced Touchscreen Display**
intuitive condition alerts, with user friendly cleaning and operation visual guidance, multi-lingual
- **Enhanced Visual On-board Diagnostics**
quickly identify machine faults for rapid resolution and less downtime
- **Automatic Tank Fill**
- **Programmable Machine Dwell**
pauses rack in wash zone for extended cleaning, NSF Certified Pot & Pan Mode
- **Automatic Drain Valve**
- **Single-Piece Hood Design**
- **Single-Piece Scrap Screen**
more robust and faster cleaning
- **Single-Piece Stainless Steel Upper And Lower Wash Arm Manifolds**
- **Single-Point Electrical Connection**
- **20" Standard Vertical Clearance**
accommodates 18" x 26" sheet pans
- **Fully Insulated Doors**
open a full 180° for unrestricted cleaning access
- **All Stainless Steel Heavy Gauge Construction**
including base, legs and feet
- **Enclosure Panels** (front and sides)
- **2 HP Pump Motor** with stainless steel impeller
- **Factory Authorized Start-Up**
- **Vent Fan Control**
- **ENERGY STAR[®] Certified**
- **Made in America**

SPECIFIER STATEMENT

Specified unit will be Champion Model 44 PRO w/Heat Recovery Option (steam) high temperature rack conveyor dishwashing machine. Features top mounted Prodigy HMI user interface controls with proactive maintenance software, proportional rinse, using only 100 GPH, built-in booster, progressive anti-jam drive system, energy sentinel (idle pump shut-off), 209 racks per hour, single-piece hood design, single-piece stainless steel upper & lower wash arms manifolds, full 180° opening leak proof insulated hinged access doors.

1 Year parts and labor warranty.

In the USA:

3765 Champion Blvd, Winston-Salem, NC 27105
Tel: (336) 661-1556 Fax: (336) 661-1979
www.championindustries.com

In Canada:

2674 N. Service Rd., Jordan Station, Ontario, Canada LORISO
Tel: (905) 562-4195 Fax: (905) 562-4618
www.championindustries.com/icanada

ACCESSORIES

- Drain water tempering kit (unmounted)
- Table limit switch, unmounted (recommended on all rack conveyor installations) (unmounted)
 - o WHISKER STYLE
 - o BUTTON STYLE
- Vent cowl, stainless steel with 7" stacks & locking dampers
- Flanged feet (unmounted)
- Water hammer kit (unmounted)
- Chemical pump kit (detergent and rinse aid, mounted and interwired)
- Water pressure regulating valve (unmounted; standard with booster)
- ION scale prevention device (unmounted) (HW & CW lines)
- Water softening system (manufactured, warrantied and serviced by Kinetico)
- Dish racks:
 - o PEG RACK
 - o FLAT RACK
 - o SHEET PAN RACK
- Splash shields (load end only)
- Cantilever sideloader (without hood) for 90° load operation
 - o 24" SIDELOAD
 - o 30" SIDELOAD (ACCEPTS SHEET PANS)
- Model PRO-90B unloader (90° corner conveyor table)
- Model PRO-90B loader (90° corner conveyor table)
- Model RCT 64 or RCT 84 roller conveyor table (see factory for custom length)
- Stainless steel rear enclosure panels
- Correctional package (contact factory)

OPTIONS

- 33" Blower dryer – steam
- Direct link connectivity solution
- Direct link plus+ connectivity solution

**Cantilever
Sideloader**
(no hood)



PRO-90B
90° Corner Conveyor
table loader and
unloader available



Model RCT 64 or RCT 84
Roller conveyor table



UTILITIES

1	Electrical Connections Machine electrical connection and booster electrical connection
2	Hot Water 25 PSI machine with built-in booster Main connection 1/2" NPT, 110° incoming water
3A	Cold Water 30 PSI Connection 1/2" NPT; 55° Minimum
5A	Drain Connection 1-1/4" NPT Drain Max Flow Rate (g/min) 15
6A	Steam 1-1/4" NPT machine & booster (10-30 PSI) flow pressure
7A	Condensate 3/4" NPT machine return to boiler. No back pressure.
8	Vents A Stack connection – load end 200 CFM @ 1/4" static pressure B Stack connection – unload end 200 CFM @ 1/4" static pressure

Warning: Plumbing and electrical connections should be made by qualified personnel who will observe all the applicable plumbing, sanitary, and safety codes and the National Electrical Code.

Note: Water Hammer Arrestor (meeting ASSE-1010 standard or equivalent) to be supplied (by others) in common water supply line at service connection.

Plumbing Notes: Because of the variation in house-supplied steam and water pressures, steam and water pressure regulating valves (PRVs) may be needed. (Water PRV is standard on machines with booster.) The PRVs can either be purchased from Champion or obtained locally.

Water hardness of 3 grains/US Gal (0.83 Imp Gal) – 5.3 Mg/L or less

Venting Notes: Fabricated duct size: 3-7/8" x 15-7/8" (outside dimensions)

Note: Freezing air must not be allowed to be drawn down into the heat recovery coil when building vent fan is off if direct vent ducting is connected to the machine.

Optional Drain Tempering: 1/2" NPT cold water connection required. 1/2" NPT drain connection from back flow preventer to house drain. (FIELD INSTALLED and PLUMBED).

SPECIFICATIONS

Capacity	
Racks per hr (NSF rated)	209
Wash tank (US gal.)	17
Conveyor speed (ft/min)	5.8
Conveyor speed Pot/Pan Mode (ft/min) (only one rack at a time in pot/pan)	4.5
Motor Horsepower	
Drive	1/6
Wash	2
Water Consumption	
US Gal. per hr (max. use)	100
US Gal. per rack	0.48
Heating 10-30 PSI flow pressure	
Tank heat, steam (lbs./hr. required)	75
Steam booster (lbs./hr. required for 70° F rise)	110
Booster heaters completely inter plumbed, controls are interwired.	
Venting	
Load end (minimum CFM)	200
Unload end (minimum CFM)	200
Standard 20"x 20" Rack Complement	
Peg	1
Flat	1

44 PRO w/Heat Recovery Option (Steam) Tank Heat, with 70°F Rise Booster			
Elec. Specs	Rated Amps	Minimum Supply Ckt. Conductor Ampacity	Maximum Overcurrent Protective Device
208/60/3	10	15	15
240/60/3	11	15	15
480/60/3	5	15	15
575/60/3	4	15	15

Champion®

The Dishwashing Machine Specialists

44 PRO w/ Heat Recovery Steam

HIGH TEMPERATURE STEAM RACK CONVEYOR

Shipping weight crated: 600 lbs. Dimensions shown in inches

Front View

Left to Right Model

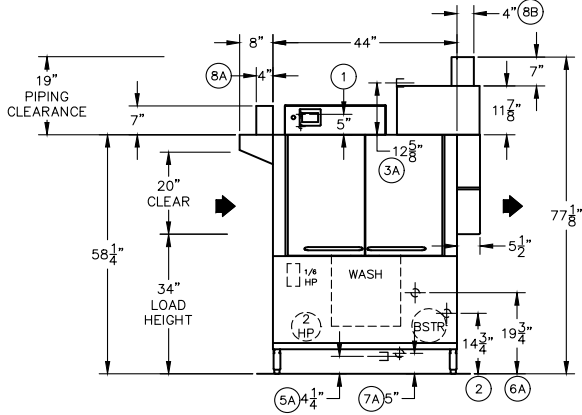

Right to Left Model

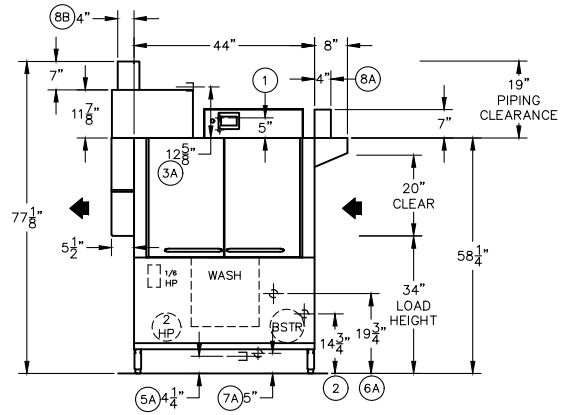

Plan View

Left to Right Model

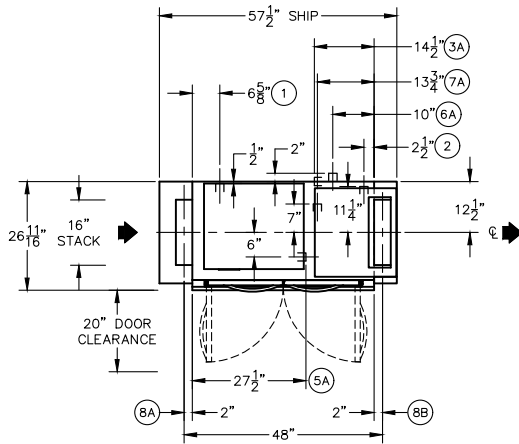

Right to Left Model

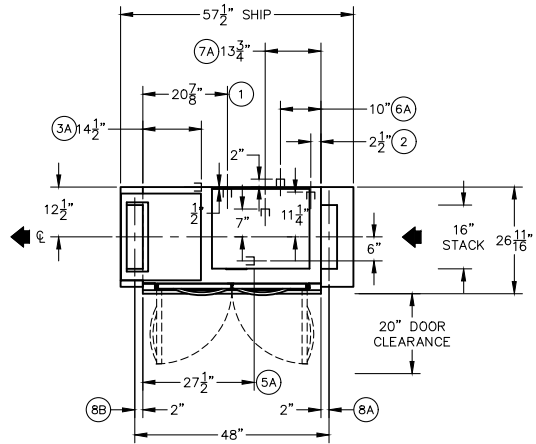

End View

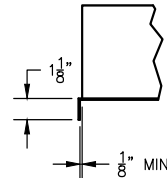
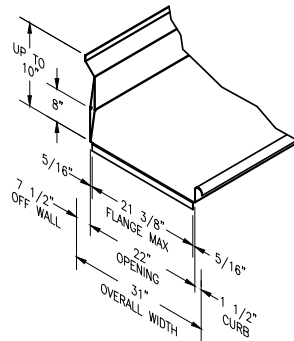
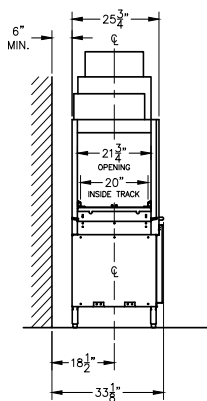

Suggested Table Construction

Flange Details

In the USA: 3765 Champion Blvd, Winston-Salem, NC 27105 | Tel: (336) 661-1556 Fax: (336) 661-1979 | www.championindustries.com

In Canada: 2674 N. Service Rd., Jordan Station, Ontario, Canada LORISO | Tel: (905) 562-4195 Fax: (905) 562-4618 | www.championindustries.com/1canada

Rev. 08/2024 Printed in U.S.A.

Due to an ongoing value analysis program at Champion, specifications contained in this catalog are subject to change without notice.