

Champion®

The Dishwashing Machine Specialists

Project _____

Item No. _____

Quantity _____

PRO SERIES RACK CONVEYOR

STANDARD FEATURES

- Exhaust air energy recovery - reuses waste energy to preheat incoming water
- Perpetual rack advance system, with intuitive jam alert, and drive protection
- Proportional rinse, delivering unmatched total ware coverage, utilizing digital pattern cloning stainless steel nozzles
- 255 Racks per hour
- 100 GPH with energy sentinel (idle pump shut-off)
- Prodigy series HMI display, intuitive condition alerts, with user friendly cleaning and operation visual guidance, multi-lingual, touch control
- Proactive maintenance interface, self-diagnostics, problem recognition, with repair recommendation, from HMI touch screen
- Programmable machine dwell with automatic rack alignment into the optimal wash zone
- Automatic drain valve
- Single-piece hood design
- Single-piece stainless steel upper and lower wash arm manifolds
- Single-point electrical connection
- 20" Standard vertical clearance which accommodates 18" x 26" sheet pans
- Full 180° opening leak proof insulated hinged access doors
- Stainless steel heavy gauge construction including base, legs and feet
- Enclosure panels (front and sides)
- 2 Hp pump motor, with stainless steel impeller
- Factory authorized start-up
- Vent fan control
- **ENERGY STAR® Certified**
- **Made in America**



Customers save \$1500 per year in energy cost on average when compared to a standard machine!

90 PRO-HD w/Heat Recovery Option (Steam)

54" Single Tank + 36" Heavy Duty Prewash

High Temperature Rack Conveyor

Dishwashing Machine



Photo is for general visual representation only. Please refer to specifications for the latest detailed product information.

SPECIFIER STATEMENT

Specified unit will be Champion Model 90 PRO-HD w/Heat Recovery Option (steam) high temperature rack conveyor dishwashing machine. Features top mounted Prodigy HMI user interface controls with proactive maintenance software, proportional rinse, using only 100 GPH, built-in booster, progressive anti-jam drive system, energy sentinel (idle pump shut-off), 255 racks per hour, single-piece hood design, single-piece stainless steel upper & lower wash arms manifolds, full 180° opening leak proof insulated hinged access doors.

1 Year parts and labor warranty.

Champion Industries, Inc.
3765 Champion Blvd., Winston-Salem, NC 27105
Tel: 336-661-1556 Fax: 336-661-1979
championindustries.com

Champion Industries, Inc.
2764 North Service Rd., Jordan Station, Ontario Canada L0R 1S0
Tel: 905-562-4195 Fax: 905-562-4618
championindustries.com/1canada

90 PRO-HD w/Heat Recovery Option (Steam)

54" Single Tank + 36" Heavy Duty Prewash
High Temperature Rack Conveyor
Dishwashing Machine

Champion[®]
The Dishwashing Machine Specialists

OPTIONS

- 33" Blower dryer – steam
- Direct link connectivity solution
- Direct link plus+ connectivity solution

ACCESSORIES

- Drain water tempering kit (unmounted)
- Table limit switch, unmounted (recommended on all rack conveyor installations) (unmounted)
 - Whisker style
 - Button style
- Vent cowl, stainless steel with 7" stacks & locking dampers
- Flanged feet (unmounted)
- Water hammer kit (unmounted)
- Chemical pump kit (detergent and rinse aid, mounted and interwired)
- Water pressure regulating valve (unmounted) (standard with booster)
- ION scale prevention device (unmounted) for HW & CW lines
- Water softening system (manufactured, warranted and serviced by Kinetico)
- Dish racks:
 - Peg rack
 - Flat rack
 - Sheet pan rack
- Splash shields (load end only)
- Cantilever sideloader (without hood) for 90° load operation
 - 24" Sideload
 - 30" Sideload (accepts sheet pans)
- Model PRO-90B loader or unloader (90° corner conveyor table)
- Model RCT 64 or RCT 84 roller conveyor table (see factory for custom length)
- Stainless steel rear enclosure panels
- Correctional package (contact factory)



NEW PRO-90B
90° Corner Conveyor
table (shown)
Loader or Unloader



Cantilever Sideloader
(no hood)



**Model RCT 64 or
RCT 84**

Roller conveyor
table

90 PRO-HD w/Heat Recovery Option (Steam)

54" Single Tank + 36" Heavy Duty Prewash
High Temperature Rack Conveyor
Dishwashing Machine



| Utilities | |
|-----------|--------------------------------------------------------------------------------------------------------------------------------------------------------------|
| 1 | Electrical Connection Machine electrical connection |
| 2 | Hot Water 25 PSI machine with built-in booster Main connection 1/2" NPT |
| 3A | Cold Water 30 PSI Connection 1/2" NPT; 55° Minimum |
| 5A | Drain Connection 1-1/4" NPT Drain Max Flow Rate (g/min) 15 |
| 6A | Steam 1-1/4" NPT machine & booster (10-30 PSI) flow pressure |
| 7A | Condensate 3/4" NPT Machine return to boiler. No back pressure. |
| 8 | Vents A Stack connection - load end 150 CFM @ 1/4" static pressure B Stack connection - unload end 200 CFM @ 1/4" static pressure |

Warning: Plumbing and electrical connections should be made by qualified personnel who will observe all the applicable plumbing, sanitary, safety codes and the National Electrical Code.

Note: Water Hammer Arrestor (meeting ASSE-1010 standard or equivalent) to be supplied (by others) in common water supply line at service connection.

Optional Drain Tempering: 1/2" NPT cold water connection required. 1/2" NPT drain connection from back flow preventer to house drain. (FIELD INSTALLED and PLUMBED).

Plumbing Notes: Because of the variation in house-supplied steam and water pressures, steam and water pressure regulating valves (PRVs) may be needed (water PRV is standard on machines with booster). The PRVs can either be purchased from Champion or obtained locally.

Recommended water hardness of 3 grains/US Gal (0.83 Imp Gal) - 5.3 Mg/L or less

Note: Freezing air must not be allowed to be drawn down into the heat recovery coil when building vent fan is off if direct vent ducting is connected to the machine.

Venting Notes: Fabricated duct sizes: 3-7/8" x 15-7/8" (outside dimensions).

SPECIFICATIONS

Capacity

| | |
|---------------------------------------------|-----|
| Racks per hr. (NSF rated)..... | 255 |
| Wash tank (US gal.)..... | 17 |
| Prewash tank (US gal.)..... | 17 |
| Conveyor speed (ft./min.)..... | 7.1 |
| Conveyor speed Pot/Pan Mode (ft./min.)..... | 5.4 |
| (only one rack at a time in pot/pan) | |

Motor Horsepower

| | |
|---------------|-----|
| Drive | 1/6 |
| Wash | 2 |
| Prewash | 2 |

Water Consumption

| | |
|---------------------------------|-----|
| US Gal. per hr. (max use) | 100 |
| US Gal. per rack | .39 |

Heating 10-30 PSI flow pressure

| | |
|-------------------------------------------------------|-----|
| Tank Heat, steam (lbs./hr. required) | 75 |
| Steam booster (lbs./hr. required for 70°F rise) | 110 |

Booster heaters completely inter plumbed, controls are interwired.

Venting

| | |
|--------------------------------|-----|
| Load end (minimum CFM) | 150 |
| Unload end (minimum CFM) | 200 |

Standard 20" X 20" rack complement

| | |
|------------|---|
| Peg | 1 |
| Flat | 1 |

| 90 PRO-HD w/Heat Recovery Option (Steam) Tank Heat, with 70°F Rise Booster | | | |
|----------------------------------------------------------------------------|------------|---------------------------------|---------------------------------------|
| Electrical Specifications | Rated Amps | Minimum Supply Circuit Ampacity | Maximum Overcurrent Protective Device |
| 208/60/3 | 16 | 20 | 20 |
| 240/60/3 | 15 | 20 | 20 |
| 480/60/3 | 7 | 15 | 15 |
| 575/60/3 | 6 | 15 | 15 |

90 PRO-HD w/Heat Recovery Option (Steam)

54" Single Tank + 36" Heavy Duty Prewash
 High Temperature Rack Conveyor
 Dishwashing Machine



90 PRO-HD w/Heat Recovery Option (Steam)

Shipping weight crated: **1075 lbs.**

Dimensions shown in inches [mm]

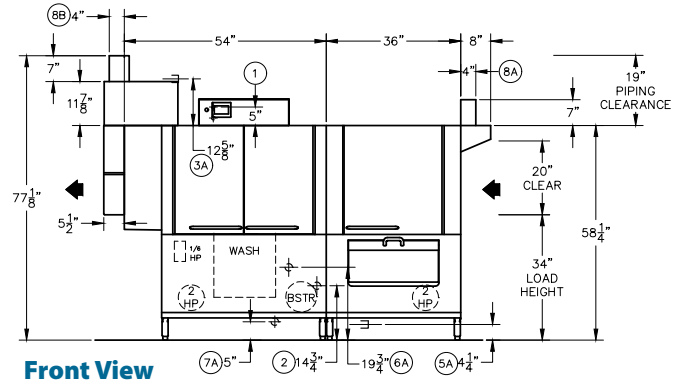
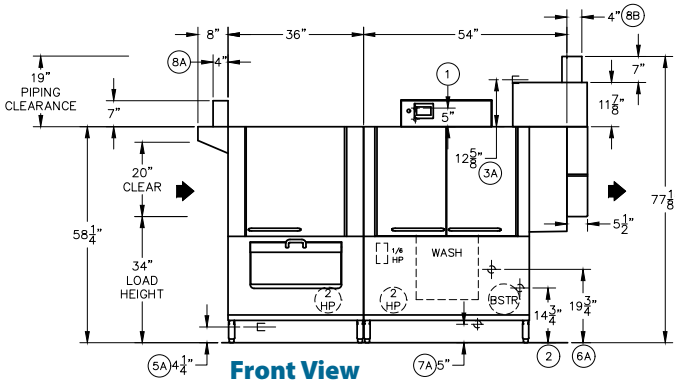

Plan View Left to Right

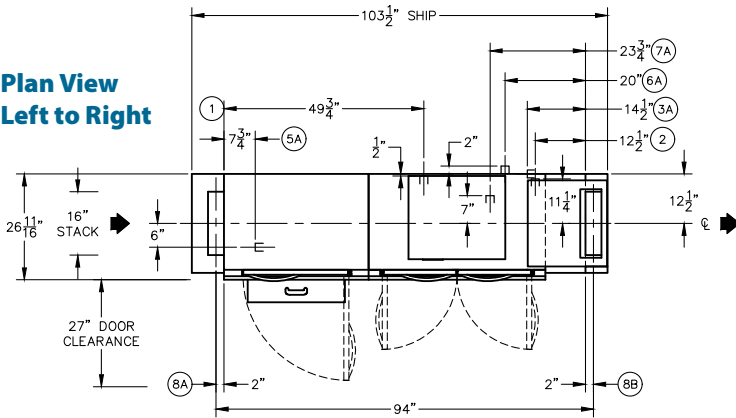

Plan View Right to Left

