



WELLS MANUFACTURING
265 Hobson Street, Smithville, Tennessee 37166
telephone: 800-264-7827
www.wells-mfg.com

022

OPERATION MANUAL

BUILT-IN BAIN MARIE STYLE HEATED TANKS



Model HTI-3060AF shown

**MODELS
HTI400AF**

**Includes
INSTALLATION
USE & CARE**

IMPORTANT: DO NOT DISCARD THIS MANUAL

This manual is considered to be part of the appliance and is to be given to the OWNER or MANAGER of the restaurant, or to the person responsible for TRAINING OPERATORS of this appliance. Additional manuals are available from your WELLS DEALER.

THIS MANUAL MUST BE READ AND UNDERSTOOD BY ALL PERSONS USING OR INSTALLING THIS APPLIANCE. Contact your WELLS DEALER if you have any questions concerning installation, operation or maintenance of this equipment.

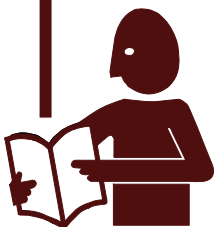

LIMITED EQUIPMENT WARRANTY

Wells Manufacturing warrants to the original purchaser of new Wells products to be free from defects in material or workmanship, under normal and proper use and maintenance service as specified by Wells and upon proper installation and start-up in accordance with the instructions supplied with each Wells unit. Wells' obligation under this warranty is limited to a period of one [1] year beginning from the date of original installation. The warranty period begins upon the earlier of the date of original installation or up to six [6] months after the original shipment, from the factory, of the covered product. Defects that occur as a result of normal use, within the time period and limitations defined in this warranty, will at Wells' discretion have the parts replaced or repaired by Wells or a Wells-authorized service agency.

THIS WARRANTY IS SUBJECT TO ALL LISTED CONDITIONS

Repairs performed under this warranty are to be performed by a Wells authorized service agency. Wells will not be responsible for charges incurred or service performed by non-authorized repair agencies. In all cases, the nearest Wells-authorized service agency must be used. Wells will be responsible for normal labor charges incurred in the repair or replacement of a warranted product within 50 miles (80.5 km) of an authorized service agency. Time and expense charges for anything beyond that distance will be the responsibility of the owner. All labor will need to be performed during regular service hours. Any overtime premium will be charged to the owner. For all shipments outside the U.S.A. and Canada, please see the International Warranty for specific details. It is the responsibility of the owner to inspect and report any shipping damage claims, hidden or otherwise, promptly following delivery. No mileage or travel charges will be honored on any equipment that is deemed portable. In general, equipment with a cord and plug weighing less than 50 lb. (22.7 kg) is considered portable and should be taken or shipped to the closest authorized service agency, transportation prepaid.

CONTACT

Should you require any assistance regarding the operation or maintenance of any Wells Manufacturing; phone or email our service department. In all correspondence provide the model number and serial number of the unit needing service; include the voltage or gas type.

Normal Business Hours: 8:00 a.m. to 4:30 p.m. Central
 Telephone: 800-264-7827 Tech Service Option 2
 Email: TechService@partstown.com
www.Wells-Mfg.com

PRODUCTS	PARTS	LABOR
Universal Ventless Hoods (WVU)	1 year	1 year
Canopy Ventless Hoods (WVC)	1 year	1 year
*Universal ventless hoods and/or canopy ventless hoods purchased with approved Star Holdings electric equipment. **Star Holdings approved electric equipment purchased and installed a under ventless hood. *** Universal ventless hood and Star Holdings electric equipment must be on the same po and listed on the ventless start-up document for the 2-year warranty to apply.	2 years	2 years
"Cook'n Hold equipment (HW-106D)	2 years	2 years
Cast iron gates, burners and burner shields	1 year	
Original Wells parts sold to repair Wells equipment	90 days	

WARRANTY EXCLUSIONS

THE FOLLOWING WILL NOT BE COVERED UNDER WARRANTY.

Wells' sole obligation under this warranty is limited to either repair or replacement parts, subject to the additional limitations detailed below. This warranty neither assumes nor authorizes any person to assume obligations other than those expressly covered by this warranty.

- Any product which has not been used, maintained, or installed in accordance with the directions published in the appropriate installation sheet and/or owner's manual, including incorrect gas or electrical connection. Wells is not liable for any unit which has been mishandled, abused, misapplied, subjected to harsh chemicals, modified by unauthorized personnel, damaged by flood, fire, or other acts of nature [or God], or which have an altered or missing serial number.
- Installation, labor, and job checkouts, calibration of heat controls, air and gas burner/bypass/pilot adjustments, gas or electrical system checks, voltage and phase conversions, cleaning of equipment, or seasoning of griddle surface.
- Replacement of fuses or resetting of circuit breakers, safety controls, or reset buttons.
- Replacement of broken or damaged glass components, quartz heating elements, and light bulbs.
- Labor charges for all removable and consumable parts in gas charbroilers and hotplates, including but not limited to burners, grates, and radiants.
- Any labor charges incurred by delays, waiting time, or operating restrictions that hinder a service technician's ability to perform service.
- Replacement of parts that fail or are damaged due to normal wear or labor for replacement of parts that can be replaced during a daily cleaning routine, such as but not limited to silicone belts, PTFE non-stick sheets, control labels, knobs, bulbs, fuses, quartz heating elements, baskets, racks, and grease drawers.
- Any economic loss of business or profits.
- Non-OEM parts. Use of non-OEM parts without Wells' approval will void the warranty.
- Units exceeding one [1] year from original installation date.

ADDITIONAL WARRANTIES

- Specific/chain-specific equipment may have additional and/or extended warranties.

The foregoing warranty is in lieu of any and all other warranties expressed or implied and constitutes the entire warranty.

TABLE OF CONTENTS

WARRANTY	xi
SPECIFICATIONS	1
FEATURES & OPERATING CONTROLS	2
PRECAUTIONS & GENERAL INFORMATION	4
INSTALLATION	5
OPERATION	7
CLEANING INSTRUCTIONS	8
MAINTENANCE INSTRUCTIONS	10
TROUBLESHOOTING SUGGESTIONS	11
NOTES	12
EXPLODED VIEW	13
PARTS LIST	14
WIRING DIAGRAM	15
NOTES	16
PARTS & SERVICE	17

INTRODUCTION

Thank You for purchasing this Wells Manufacturing appliance.

Proper installation, professional operation and consistent maintenance of this appliance will ensure that it gives you the very best performance and a long, economical service life.

This manual contains the information needed to properly install this appliance, and to use and care for the appliance in a manner which will ensure its optimum performance.

ELECTRICAL SPECIFICATIONS

MODEL	VOLTS	WATTS	AMPS PER LEG 3 ϕ			AMPS 1 ϕ
			L1	L2	L3	
HTI400AF	208	9000	25.0	25.0	25.0	43.3
	240	12000	28.9	28.9	28.9	50.0

Units are shipped from the factory wired 3 ϕ , and are field convertible to 1 ϕ .

Field wiring for 3 ϕ must be at least 10 ga. copper.

Field wiring for 208 volt 1 ϕ must be at least 8 ga. copper.

Field wiring for 240 volt 1 ϕ must be at least 6 ga. copper

Field wiring for all units must suitable for at least 90°C.

FEATURES & OPERATING CONTROLS

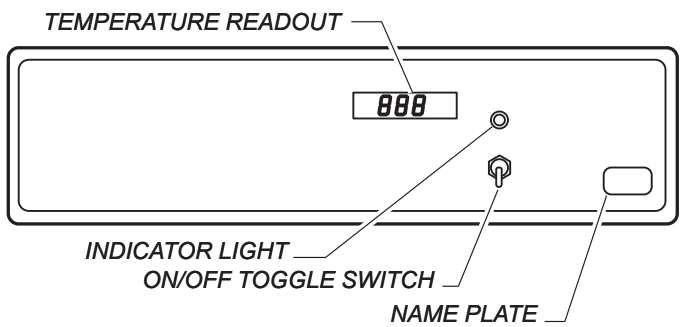
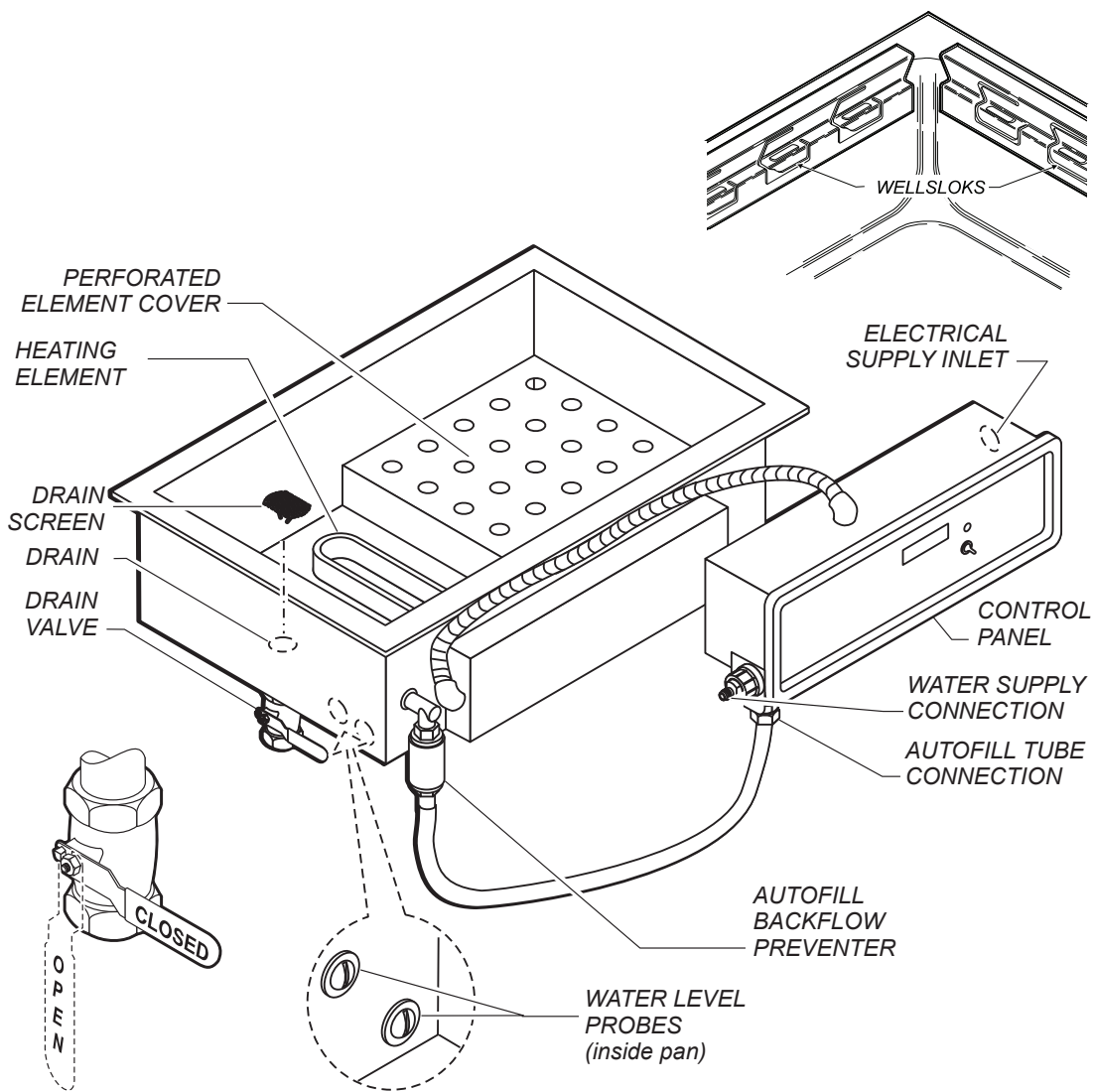

IL2084 REV A (05-23)

FEATURES & OPERATING CONTROLS (continued)

A. CONTROLS

The ON/OFF toggle switch controls power to the warmer.

The INDICATOR LIGHT will glow when the ON/OFF switch is turned ON.

The TEMPERATURE READOUT displays the current temperature of the water bath. Temperature of the water bath is pre-set at 190°F (88°C). Actual temperature of the food product will vary depending upon type of product, food consistency and other such variables.

The HEATING ELEMENT is energized when:

- a. The water bath is below the set temperature; and,
- b. The lower water level probe senses water.

Heating elements are protected from contact with food containers by perforated element covers.

B. AUTOFILL

Water is automatically fed into the tank when:

- a. The ON/OFF toggle switch is turned ON ; and,
- b. The upper water level probe does not sense water.

C. WELLSLOKS

Built-in heated tanks are equipped with WELLSLOKS, uniquely designed turnout tabs which help secure the tank flange to the counter top.

(See Installation Instructions, supplied with the appliance, for details.)

D. DRAIN VALVE

Built-in heated tanks are equipped with a 1" NPT drain and 1/4-turn valve. Valve lever "down" is open; "up" is closed. Valve must be closed for operation.

A drain screen is provided to help prevent drain clogs. The drain screen should be in place at all times during operation.

E. NAME PLATE

Manufacturer information, as well as model, serial number and electrical requirements are listed on the NAME PLATE.

NOTE:

Heating elements must be completely covered with water at all times during operation.

Water supply must be properly connected to the warmer and turned ON. before operating the unit.

Drain valve must remain fully closed during operation.

Perforated element covers must be properly installed at all times during operation.

PRECAUTIONS AND GENERAL INFORMATION



WARNING: SHOCK HAZARD

All servicing requiring access to non-insulated electrical components must be performed by a factory authorized technician.

DO NOT open any access panel which requires the use of tools. Failure to follow this warning can result in severe electrical shock.



CAUTION: Risk of Damage

DO NOT connect or energize this appliance until all installation instructions are read and followed. Damage to the appliance may result if these instructions are not followed.



CAUTION: Hot Surface

Exposed surfaces can be hot to the touch and may cause burns.

This appliance is intended for use in commercial establishments only.

This appliance is intended to hold pre-heated food for human consumption. No other use is recommended or authorized by the manufacturer or its agents.

Operators of this appliance must be familiar with the appliance use, limitations and associated restrictions. Operating instructions must be read and understood by all persons using or installing this appliance.

Cleanliness of this appliance is essential to good sanitation. Read and follow all included cleaning instructions and schedules to ensure the safety of the food product.

Disconnect this appliance from electrical power before performing any maintenance or servicing.

This appliance is not jet stream approved. Do not direct water jet or steam jet at this appliance, or at any control panel or wiring. Do not splash or pour water on, in or over any controls, control panel or wiring.

Exposed surfaces of this appliance can be hot to the touch and may cause burns.

Do not operate this appliance if the control panel is damaged. Call your Authorized Wells Service Agent for service.

The technical content of this manual, including any wiring diagrams, schematics, parts breakdown illustrations and/or adjustment procedures, is intended for use by qualified technical personnel.

Any procedure which requires the use of tools must be performed by a qualified technician.

This manual is considered to be a permanent part of the appliance. This manual and all supplied instructions, diagrams, schematics, parts breakdown illustrations, notices and labels must remain with the appliance if it is sold or moved to another location.

This appliance is made in the USA. Unless otherwise noted, this appliance has American sizes on all hardware.

INSTALLATION

NOTE: DO NOT discard the carton or other packing materials until you have inspected the appliance for hidden damage and tested it for proper operation. Refer to *SHIPPING DAMAGE CLAIM PROCEDURE* on the inside front cover of this manual.



WARNING: RISK OF INJURY

Installation procedures must be performed by a qualified technician with full knowledge of all applicable electrical and plumbing codes. Failure can result in personal injury and property damage.



CAUTION FIRE HAZARD

Avoid storing flammable or combustible materials in, on or near the appliance.

IMPORTANT: For warmers installed in plastic counter tops, the counter material must be protected from the heat of the warmer in order to prevent discoloration and/or deterioration. Wellsloks are not suitable for this purpose. The installer should contact the manufacturer or distributor of the countertop material for specific instructions.

IMPORTANT: Wellslok Extension Kits must be used **ONLY** with UL Listed warmers approved for installation in wood counter tops. Refer to the *Installation Instructions* provided with the warmer.

UNPACKING & INSPECTION

Carefully remove the appliance from the carton. Remove all protective plastic film, packing materials and accessories from the Appliance before connecting electrical power or otherwise performing any installation procedure.

Carefully read all instructions in this manual and the *Installation Instruction Sheet* packed with the appliance before starting any installation.

Read and understand all labels and diagrams attached to the appliance.

Carefully account for all components and accessories before discarding packing materials. Store all accessories in a convenient place for later use.

COMPONENTS

WARMER w/ CONTROL PANEL
PERFORATED ELEMENT COVERS
2 ea. HTI-300AF
3 ea for all others)
1" NPT VALVE

PREPARATION

Refer to the *Installation Instruction Sheet* for cutout dimensions and required clearances. Maintain required clearances between the appliance and adjacent combustible surfaces.

INSTALLATION

1. This is a GENERAL GUIDE. For specific cutout dimensions and other installation details, refer to the Installation Instructions supplied with the warmer.
2. Cutout dimensions for tank units and control panels are listed on the Installation Instructions provided with the warmer.
3. For "top-mounted" installation:
 - a. Verify that provided sealants are applied to the underside of the warmer top flange prior to setting the unit into the cutout.
 - b. After installation, verify that the tabs on the Wellsloks are turned out to lock the warmer into the counter.
 - c. Apply a thin bead of food-grade silicone sealant around the flange to seal it to the counter.
 - d. Wellslok extension kits are available for installing warmers in counter tops where the standard Wellslok would not normally reach. The extension kit will adapt to counter tops up to 1¾" thick.
 - e. For heated tanks installed in plastic (e.g. Corian®) counter tops, the counter material must be protected from the heat of the warmer in order to prevent discoloration and/or deterioration. Wellsloks are not suitable for this purpose. The installer should contact the manufacturer or distributor of the countertop material for specific installation instructions.

INSTALLATION (continued)

D. ELECTRICAL INSTALLATION

1. Refer to the nameplate. Verify the electrical service power. Voltage and phase must match the nameplate specifications. Wiring the warmer to the wrong voltage can severely damage the unit or cause noticeably decreased performance.
2. Available electrical service amperage must meet or exceed the specifications listed on the provided specification sheet .
3. Warmer and control unit must be connected to an appropriate building ground. Ground connection will be marked "GND" or "⏏".

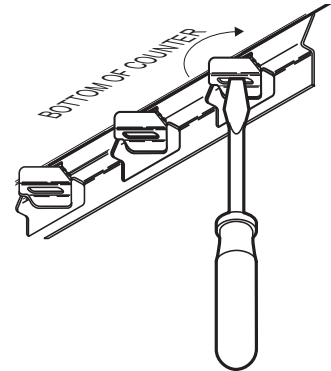

E. PLUMBING INSTALLATION

1. For use in the State of Massachusetts, this appliance must be installed in compliance with **Massachusetts Fuel Gas and Plumbing Code CMR 248**.

IMPORTANT:

All plumbing installations must be performed by a qualified plumber.

2. Some jurisdictions may require an approved back-flow preventer in the drain line. It is the responsibility of the plumber to determine such requirement, to provide the proper back-flow prevention device, and to properly install the required back-flow preventer.
3. For AUTOFILL units: Some jurisdictions may require an approved back-flow preventer in the water supply line. It is the responsibility of the plumber to determine such requirement, to provide the proper back-flow prevention device, and to properly install the required back-flow preventer. Autofill supply must be connected to a COLD WATER line only.

NOTE: Damage caused by leaks due to improper installation is NOT covered by warranty.



CAUTION: SHOCK HAZ- ARD

The ground lug of this appliance must be connected to a suitable building ground.

IMPORTANT:

Contact a licensed electrician to install and connect electrical power to the appliance.

IMPORTANT:

Damage due to being connected to the wrong voltage or phase is NOT covered by warranty.

IMPORTANT: Electrical installation other than as specified on the specification sheet will void the UL listing, and may void the warranty.

NOTE: Plumb connections must be made in compliance with all Federal, State and Local Plumbing Codes and Ordinances.

OPERATION



CAUTION: Hot Surface

Exposed surfaces can be hot to the touch and may cause burns.



CAUTION: Shock Hazard

DO NOT splash or pour water onto control panel or wiring.

Always use an inset.

DO NOT place food directly into the warmer.

Always pour hot water into the warmer before it is preheated. DO NOT pour water into a dry, heated warmer. This may damage the unit.

DO NOT put ice into a warmer pan. This will cause condensation on the inside of the warmer. Damage caused by condensation is NOT covered by warranty.

Stir thick food items frequently to keep food heated uniformly.

Keep insets covered to maintain food quality and temperature.

OPERATION

Make sure the drain valve is fully closed before turning thermostat ON.

Turn ON/OFF SWITCH to ON. The INDICATOR LIGHT will glow. After several seconds the solenoid will open and begin filling the tank. When the water reaches the LOWER WATER LEVEL PROBE, the controller will energize the heating elements. The solenoid will continue filling the tank until the UPPER WATER LEVEL PROBE is reached. Keep the tank covered to reduce heat-up time.

Water level control will maintain the upper water level automatically.

Temperature of the water bath is pre-set at 190°F (88°C). The temperature on the DIGITAL DISPLAY is the actual water temperature.

Water level should be checked periodically to verify proper operation of the autofill feature. Running warmers dry will shut down the heaters causing lower food product temperature.

Operational notes:

DO: Always use pot or inset.

DO NOT place food directly into the tank.

DO NOT put ice into the tank. This will cause condensation on the inside of the tank shrouds. Damage caused by condensation is **NOT** covered by warranty.

DO: Stir thick food items frequently to keep food heated uniformly.

DO: Keep pots and insets covered to maintain food quality and temperature.

DO NOT use metal implements, steel wool, or caustic or abrasive cleansers to clean warmer pan.

DO: Clean heating elements and water level probe daily to maintain proper warmer operation.

CLEANING INSTRUCTIONS

DAILY CLEANING INSTRUCTIONS

PREPARATIONS: Turn control knob to OFF. Unplug the warmer.
Allow warmer to cool before proceeding.
Remove any insets, pans and/or adapter tops (if used). Drain water from tank.

FREQUENCY: Minimum - daily.

TOOLS: Mild Detergent
Solution: 10 Parts Warm Water to 4 Parts Vinegar
Plastic Scouring Pad
Clean Cloth or Sponge

1. Wipe entire unit down using a clean cloth or sponge and mild detergent.
2. Use a plastic scouring pad to remove any hardened food particles or mineral deposits. Pay particular attention to removing scale and lime build-up on the heating elements and water level probes.
IMPORTANT: DO NOT use steel wool for cleaning.
3. Rinse warmer thoroughly with a vinegar and water solution to neutralize all detergent cleanser residue.
4. Inspect warmer tank for damage. Damage to the tank may allow grease and water to leak into insulation and heating element, causing a potential fire and/or electric shock hazard. Contact your Authorized Wells Service Agency to inspect warmer if water or grease contamination is suspected.
5. Add proper amount of warm water. Turn control knob ON and check for proper operation.



**CAUTION:
SHOCK HAZARD**

Do NOT splash or pour water into or over any control panel or wiring.



**CAUTION:
SHOCK HAZARD**

Disconnect warmer from electric power before cleaning



**CAUTION:
BURN HAZARD**

Allow warmer to cool completely before cleaning.

CLEANING INSTRUCTIONS (continued)



CAUTION: CHEMICAL BURN HAZARD

Deilimng chemicals may be caustic. Wear appropriate personal protective equipment. Follow cleaner manufacturer's instructions for safest use.

WEEKLY CLEANING INSTRUCTIONS

PREPARATIONS: Remove any insets, pans and/or adapter tops. Drain or remove water from well if used for wet operation.

FREQUENCY: Weekly, or whenever lime or scale is seen accumulating on the sides of the warmer pans.

TOOLS: Commercial Delime Cleaner
Plastic Scouring Pad
Clean Cloth or Sponge

1. Add water to pans until water is at normal operating level (1" - 1 1/2" deep) or covers accumulated scale.
2. Heat water to maximum temperature (190°F or higher).
3. Pour contents of one package of commercial delime cleaner into each warmer pan. Stir to dissolve cleaner. Turn heat control OFF. Cover pans.
4. Allow solution to soak at least one hour, or overnight for heavy scale buildup.
5. Drain hot water from pans. Scrub with a plastic scouring pad. Rinse thoroughly with hot water, then dry.
6. Refill pans with hot tap water and resume operation.
7. Heavy scale buildup may require additional treatments.

MAINTENANCE INSTRUCTIONS

ADJUST WATER TEMPERATURE

Turn ON/OFF SWITCH to *OFF*. Disconnect unit from electric power.

Remove screws from lip of control panel. Lift panel out of cabinet.

Reconnect unit to electric power. Turn ON/OFF SWITCH to *ON*.

Press and hold TEMP SET button on controller until display shows current temperature setpoint.

While holding SET TEMP button, press UP ARROW or DOWN ARROW until desired setpoint temperature is displayed. (165°F to 210°F / 73.8°C to 98.8°C) Release buttons.

Turn ON/OFF SWITCH to *OFF*. Disconnect unit from electric power.

Reassemble control panel to cabinet.

Reconnect unit to electric power. Turn ON/OFF SWITCH to *ON*.

Test unit for proper operation.

CARE OF STAINLESS STEEL

External components, such as cabinets and control panels, are finished with a grain pattern. This pleasing finish is best maintained by cleaning with a non-abrasive cleanser applied with a soft cloth. Rub only in the direction of the grain. In the absence of visible grain, rub only along the longest axis of the appliance.

Restore stainless steel's luster by applying a polish specifically made for stainless steel. Spray on, wipe off with a soft cloth, rubbing in the direction of the grain.

Keep your stainless steel warmers clean and free from calcium buildup.

Use alkaline, alkaline chlorinated or non-chloride cleanser.

Use citric acid-based cleaners to remove calcium deposits.

Wells Lime & Scale Cleaner (p/n 22838) is recommended.



CAUTION ELECTRIC SHOCK HAZARD

Live electric circuits are exposed during this adjustment procedure.

This procedure must be performed by qualified technicians only.

Disconnect unit from electric power before beginning this procedure.

IMPORTANT:

Never use metal implements, wire brushes, abrasive scratch pads or steel wool to clean stainless steel.

For additional information, please read the NAFEM Stainless Steel Equipment and Cleaning Guide. Contact NAFEM at :
North American Association of Food Equipment Manufacturers
401 N. Michigan Avenue
Chicago, Illinois 60611-4267
(312) 644-6610

TROUBLESHOOTING SUGGESTIONS

SYMPTOM	POSSIBLE CAUSE	SUGGESTED REMEDY
No power to warmer	Circuit breaker off or tripped	Reset circuit breaker
	Unit not plugged in	Make sure unit is plugged in to power receptacle
Warmer will not heat	Temperature control not set	Set control to desired temperature
	Internal damage	Contact you Authorized Wells Service Agency for repairs
Autofill does not add water to warmer	Water supply not turned on	Turn on water supply
	Internal damage	Contact you Authorized Wells Service Agency for repairs
Warmer overflows (Autofill does not shut off water fill)	Scale build-up on water level probe	Clean water level probe with delime cleaner
	Internal damage	Contact you Authorized Wells Service Agency for repairs
Warmer trips circuit breaker	Tank leaking or other internal damage	Contact you Authorized Wells Service Agency for repairs
	Internal damage	Contact you Authorized Wells Service Agency for repairs
Warmer slow to heat	Mineral deposits on tank acting as a insulator	Clean tank with delime cleaner
	Connected to wrong voltage	Verify supply voltage - must match voltage on warmer nameplate
	Too much water	Remove water from pan until 1" of water remains in tank

There are no user-serviceable components in this appliance.
 In all instances of damage or malfunction, contact your Authorized Wells Service Agency for repairs.

NOTES

EXPLODED VIEW - HTI400

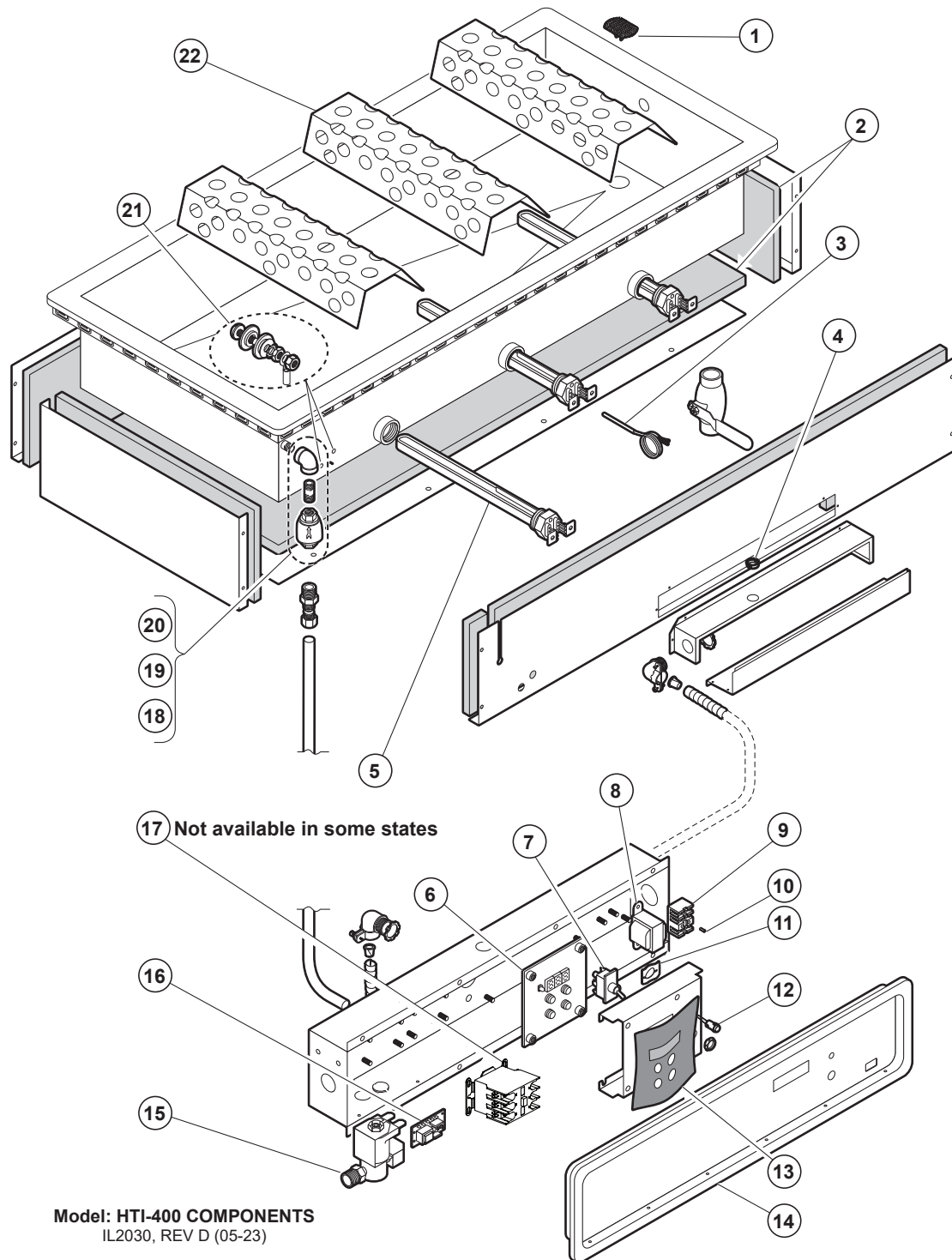

PARTS LIST - HTI400

HTI-400 SERIES BAIN WARMER		
Item No	Part Number	Description
1	2V-Z17446	SCREEN DRAIN WARMERS
2	2H-36050	INSUL FG .6 MICRO 1X36
3	2J-306320	PROBE TEMP HTI 72 WIRES
4	2K-Y1139	BUSHING HEYCO SB500-6
5	2N304637UL	ELEM FIREBAR HTI400 240V
6	2T-307364	CONTROL TEMP HTI UPGRD 30 REPLACES WS-507364/501277
7	2E-30330	SWITCH ON OFF TOGGLE 20A REPLACES WS-50330
8	2E-31400-26	XFORMR 208-240/24-12 40VA CL2
9	WS-50131	TERM BLK KIT-3 POLE, 85AMP
10	2C-41974	NUT 8-32 HEX 7/8 LONG ALU
11	2C-20602-03	CLIP RETAINER PILOT LIGHT
12	2J-35687	LT SGNL,GLODOT
13	2M-301295	DISPLAY WINDOW HTI SERIES
14	P2-Z12614	PANEL CONTROL HTI-400
15	2V-70774	VALVE SOLENOID 240V ROHS
16	2E-301279	CONTROL WATER LEVEL HTI
17	UNITS BUILT PRIOR TO OCTOBER 2022 NEED SERVICE KIT WS-WL1066 WHEN REPLACING 23-306967B E-SAFE RELAY	
	2E-Z14960	CONTACTOR,40A 208/240COIL
18	2V-47650	VALVE ANTISYPHON 3/8
19	2K-48197	NIPPLE 3/8 NPT X 2 BRASS
20	2K-48198	ELBOW 3/8 X 90DEG BRASS
21	WS-503713	PROBE ASSY,SS AUTOFL WRMR
22	P2-301294	COVER,ELEMENT HTI SERIES

WIRING DIAGRAM - HTI400

WIRING DIAGRAM FOR HTI-400 WARMERS
W/AUTO WATER FILL 208/240V, SINGLE & THREE PHASE

VOLTS	KW	AMPS PER LINE 3 PHASE			AMPS SINGLE PHASE
		L1	L2	L3	
208	7.5	20.8	20.8	20.8	36.0
240	10.0	24.0	24.0	24.0	41.6

50 / 60 HZ

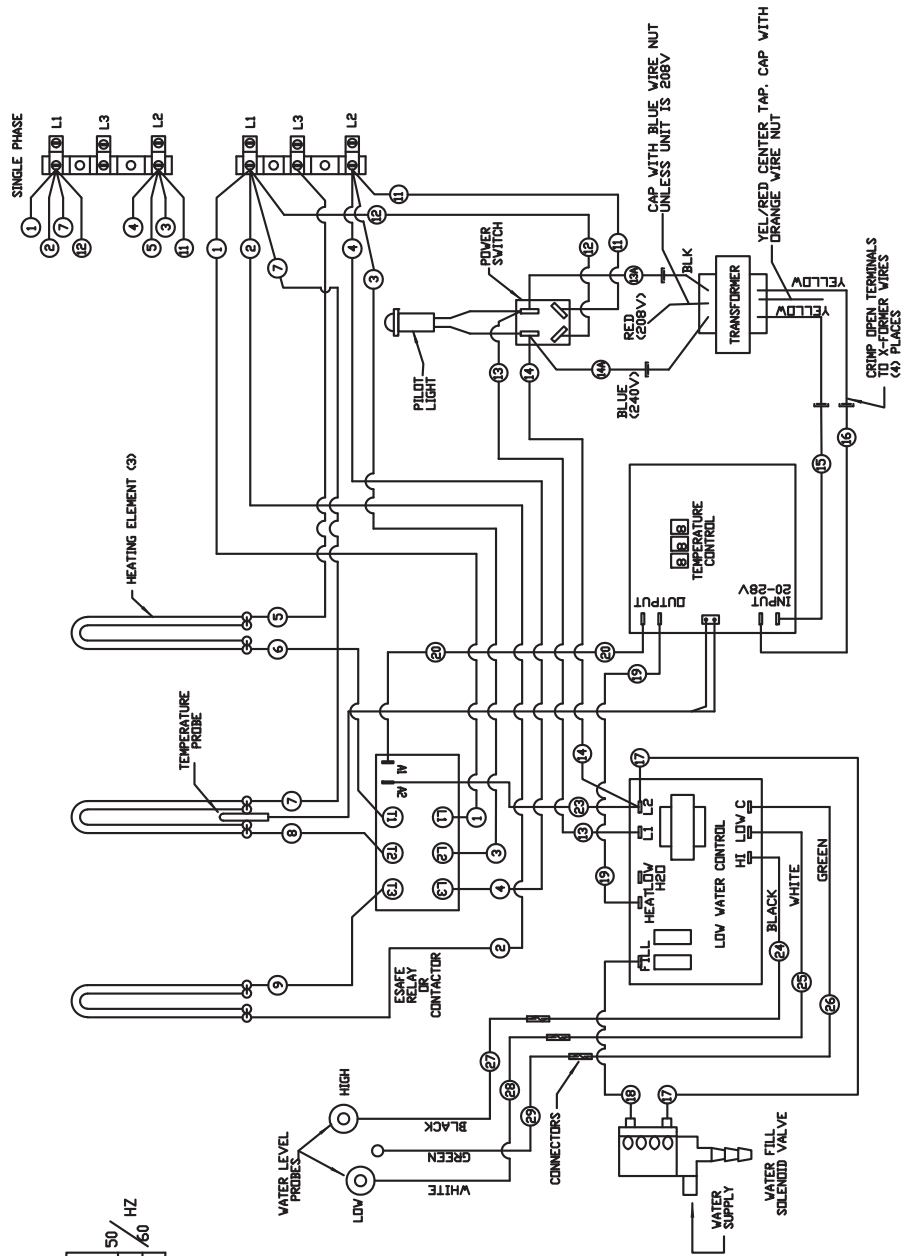

NOTES:
1. UNITS WIRED 240V BY DEFAULT. TRANSFORMER WIRES MUST BE CHANGED FOR 208V UNITS.

REV. (D) P/N 307385

NOTES

PARTS & SERVICE

DESCRIPTION	PART NO.	IMPORTANT: Use only factory authorized service parts.
8 oz. SOUP LADLE	2L-47567	
DRAIN VALVE EXTENSION KIT, extension from drain to counter front with remote handle	WS-20385	For factory authorized service, or to order factory authorized replacement parts, contact your Wells authorized service agency, or call:
DRAIN SCREEN	2V-Z17446	
Wellslok Extension Kits for UL Listed units approved for installation in wood counter tops	**	Wells Manufacturing 265 Hobosn St. Smithville, TN 37166
OPTIONAL 72" WIRING, thermostatically controlled warmers	**	Service Parts Dept. phone: (800) 264-7827 Service Parts Department can supply you with the name and telephone number of the WELLS AUTHORIZED SERVICE AGENCY nearest you.
** contact factory customer service for availability		

CUSTOMER SERVICE DATA

please have this information available if calling for service

RESTAURANT _____ LOCATION _____
 INSTALLATION DATE _____ TECHNICIAN _____
 SERVICE COMPANY _____
 ADDRESS _____ STATE _____ ZIP _____
 TELEPHONE NUMBER (____) _____ - _____
 EQUIPMENT MODEL NO. _____
 EQUIPMENT SERIAL NO. _____
 VOLTAGE: (check one) 208 240



Wells proudly supports CFESA
Commercial Food Equipment Service Association

SERVICE TRAINING - QUALITY SERVICE



CUSTOMER SATISFACTION



WELLS MANUFACTURING
265 Hobson Street, Smithville, Tennessee 37166
telephone: 800-264-7827
www.wells-mfg.com