



Impingement/Radiant Split-Belt Conveyor Toaster

Owner's Manual

Models

IRCS4 (patent pending)

This manual includes material related to installation, use, cleaning, and care. Exploded view(s), as well as any available parts list(s) and wiring diagram(s) pertaining to the unit(s) covered by this manual are also included.

This manual must be read and understood by all persons using or installing this appliance. Contact your Star dealer if you have any questions concerning installation, use, or maintenance of this equipment.

DO NOT DISCARD THIS MANUAL.

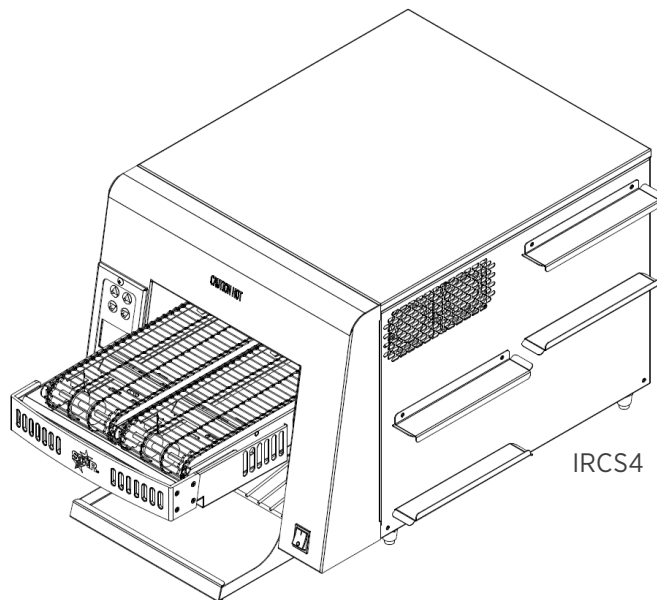

LIMITED EQUIPMENT WARRANTY

All workmanship and material in Star products have a one (1) year limited warranty on parts and labor in the United States and Canada unless otherwise noted below. Such warranty is limited to the original purchaser only and shall be effective from the date the equipment is placed in service. Star's obligation under this warranty is limited to the repair of defects without charge, by the factory authorized service agency or one of its sub-agencies. Star will not assume any responsibility for loss of revenue. Models that are considered "portable" (see below) should be taken to the closest Star service agency, transportation prepaid. On all shipments outside the U.S.A. and Canada, see the International Warranty.

This warranty does not apply to any item that is disassembled or tampered with for any purpose other than repair by a Star-authorized service center or the service center's sub-agency. This warranty does not apply if damage occurs from improper installation, misuse, wrong voltage, wrong gas or operated contrary to the Installation and operating instructions. This warranty is not valid on Conveyor Ovens unless a "start-up/check-out" has been performed by a factory authorized technician. This warranty does not apply to "Special Products" but to regular catalog items only. Star's warranty on "Special Products" is six (6) months on parts and ninety (90) days on labor.

The warranty period for Ultra-Max Hot Plates, Griddles, and Char Broilers is (3) years parts and labor.

The warranty period for Star-Max Char Broilers, Griddles, Hot Plates, Fryers, and Finishing Ovens is (2) years parts and labor.

The warranty period for JetStar series six (6) ounce and eight (8) ounce Popcorn Poppers is two (2) years.

The warranty period for Chrome-Max Griddles is five (5) years on the griddle surface. See detailed warranty provided with unit.

The warranty period for Duratec coatings is one (1) year under normal use and reasonable care. The warranty period for Staltek coatings is five (5) years under normal use and reasonable care. This warranty does not apply if damage occurs to the coating from improper cleaning or maintenance, use of metallic utensils, abrasive cleaners or pads, or damage from any other non-food object that comes in continuous contact with the roller coating. This warranty does not apply to the "non-stick" properties of such materials. This warranty is not valid on rollers purchased as replacement parts.

PARTS WARRANTY

Parts that are sold to repair out of warranty equipment are warranted for ninety (90) days. The labor to replace the part is NOT warranted.

SERVICES AND EXPENSES NOT COVERED BY WARRANTY

- Travel time and mileage rendered beyond the 50-mile radius limit
- Mileage and travel time on "portable" equipment (see below)
- Labor to replace such items that can be replaced easily during
- a daily cleaning routine (e.g., removable kettles on fryers, knobs, grease drawers on griddles, etc.)
- Installation of equipment
- Cleaning of equipment
- Seasoning of griddle plates
- Voltage conversions or gas conversions
- Pilot light adjustment
- Miscellaneous adjustments
- Thermostat calibration and bypass adjustment
- Resetting of circuit breakers, safety controls, or reset buttons
- Replacement of bulbs or fuses
- Repair of damage created during transit, delivery, or installation or created by an act of God.

PORTABLE EQUIPMENT

Star will not honor service bills that include travel time and mileage charges for servicing any products considered "portable" including items listed below. These products should be taken to the Service Agency for repair:

- Model 510FD, 510FF Fryer
- Model 526TOA Toaster Oven
- Model J4R, 4 oz. Popcorn Machine
- Model 518CMA & 526CMA Cheese Melter
- Model 12MC & 15MC & 18MCP Hot Food Merchandisers
- Model 12NCPW & 15NCPW Nacho Chip/Popcorn Warmer
- QCS/RCS series Toasters except model QCS3 & RCS3 series
- Nacho Cheese Warmers except model 11WLA series Nacho Cheese Warmer
- Condiment Dispensers except the model HPD & SPD series Dispenser
- Pretzel Merchandisers (model 16PD-A only)
- Hot Dog equipment except Roller Grills, Drawer Bun Warmers, and Direct Connect series Fast Steamers.
- Specialty Food Warmers except model 130R, 11RW series, and 11WSA series
- Pizza Ovens (model PO12 only)

All:

- Pop-Up Toasters
- Butter Dispensers
- Pastry Display Cabinets
- Nacho Chip Merchandisers
- Accessories of any kind (e.g. Sneeze Guards, Manual Pumps, etc.)
- Heat Lamps

The foregoing warranty is in lieu of any and all other warranties expressed or implied and constitutes the entire warranty.

Should you require any assistance regarding the operation or maintenance of any Star equipment; write, phone, fax or email our Service Department. In all correspondence mention the model number and the serial number of your unit, as well as the voltage or type of gas you are using.

Business hours: 8:00 a.m. to 4:30 p.m. Central Standard Time
Telephone: 314-678-6303
Fax: 314-781-2714
Email: customerservice@star-mfg.com
Website: www.star-mfg.com

TABLE OF CONTENTS

Warranty	i
General Information and Installation	1-2
Specifications	3
Daily Operation	4
Cleaning	5
Settings	6-7
Warning Screens	7
Exploded Views	8-11
Parts List	12-13
Wiring Diagram	14

NOTES

SAFETY SYMBOLS

These symbols are intended to alert the user to the presence of important operating and maintenance instructions in the manual accompanying the appliance.

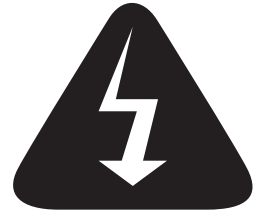

THOROUGHLY INSPECT YOUR UNIT ON ARRIVAL



This unit has been tested for proper operation before leaving our plant to ensure delivery of your unit in perfect condition. However, there are instances in which the unit may be damaged in transit. In the event you discover any type of damage to your product upon receipt, you must immediately contact the transportation company who delivered the item to you and initiate your claim with that company. If this procedure is not followed, it may affect the warranty status of the unit. If damage or loss is not apparent until after equipment is unpacked, a request for inspection of concealed damage must be made with carrier within 15 days. Please record the model number, serial number, voltage, and purchase date in the area below at the time of receipt..

Model Number _____

Serial Number _____

Voltage _____

Purchase Date _____

MAINTENANCE AND REPAIRS

Contact your local authorized service agent for service or required maintenance. Please have the information in the above fields ready when you call to ensure a faster service.

Using any part other than genuine Star factory supplied parts relieves the manufacturer of all liability. Due to periodic changes in designs, methods, procedures, policies, and regulations, the specifications contained in this sheet are subject to change without notice. Star reserves the right to change product specifications and design without notice. Such revisions do not entitle the buyer to corresponding changes, improvements, additions or replacements for previously purchased equipment. While Star International Holdings Inc. exercises good faith efforts to provide information that is accurate, we are not responsible for errors or omissions in information provided or conclusions reached as a result of using the specifications. By using the information provided, the user assumes all risks in connection with such use.

PLEASE REFER TO THE WARRANTY PAGE FOR SPECIFIC WARRANTY INFORMATION.

AUTHORIZED SERVICE AGENT LISTING

Reference the listing provided with the unit or for an updated listing go to the website or call customer service to find an agent.

Business hours: 8:00 a.m. to 4:30 p.m. Central Standard Time

Telephone: 314-678-6303

Fax: 314-781-2714

Email: customerservice@star-mfg.com

Website: www.star-mfg.com

Please visit www.starwebconnect.com/manuals.aspx for digital versions of any documents associated with this unit.



GENERAL SAFETY INFORMATION

This equipment is designed and sold for commercial use only, and is intended for use by personnel trained and experienced in its operation. This is not sold for consumer use in and around the home nor for use directly by the general public in food service locations.

Before using your new equipment, read and understand all the instructions and labels associated with the unit prior to putting it into operation. Make sure all people associated with its use understand the units operation and safety before they use the unit.

GENERAL INSTALLATION INFORMATION

The unit is shipped fully assembled and ready to plug into a standard outlet specified for its voltage and amp draw. If improper electrical supply can be determined through troubleshooting, contact a qualified electrician prior to using the unit. Removal or replacement of the power cord or plug will void the warranty. Should you require assistance, contact your local authorized service agent for any service or required maintenance.

Level unit using the adjustable feet under the unit (there is approximately 0.5 (1/2) inch of adjustment). Allow enough space around the toaster for adequate ventilation. It is recommended that you leave at least a one (1) inch gap on each side as well as at least a two (2) inch gap on the top. Do not operate the unit without the crumb tray properly positioned. If operated improperly, overheating and poor toasting may occur.

Before using the unit for the first time, ensure to clean the toaster properly. Refer to the Cleaning Procedure document for cleaning instructions.

ELECTRICAL CONNECTION

Before making any electrical connection to this unit, check that the power supply is adequate for the voltage, amperage, and requirements stated on the rating plate. This unit will require a NEMA L6-30R receptacle. Make certain to disconnect the unit from the power source before installing or removing any parts. Be absolutely sure that the ground connection for the receptacle is properly wired. Do not connect equipment to power without proper ground connections. Improper grounding may result in personal injury or fatality.



DO NOT CUT OR REMOVE THE PLUG OR GROUNDING PRONG FROM THE PLUG.



CONNECT/PLUG UNIT INTO DEDICATED AC LINE ONLY SPECIFIED ON THE DATA PLATE OF THE UNIT.



DO NOT IMMERSE OR LET THE UNIT STAND IN WATER.



DO NOT HOSE DOWN THE UNIT OR THE TABLE/COUNTER IF THE UNIT IS ON THE TABLE/COUNTER.



KEEP AWAY FROM RUNNING WATER.

ELECTRICAL REQUIREMENTS

30 amps, 208/240 volts, and a NEMA L6-30R receptacle are required.

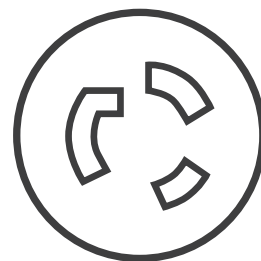

SPECIFICATIONS

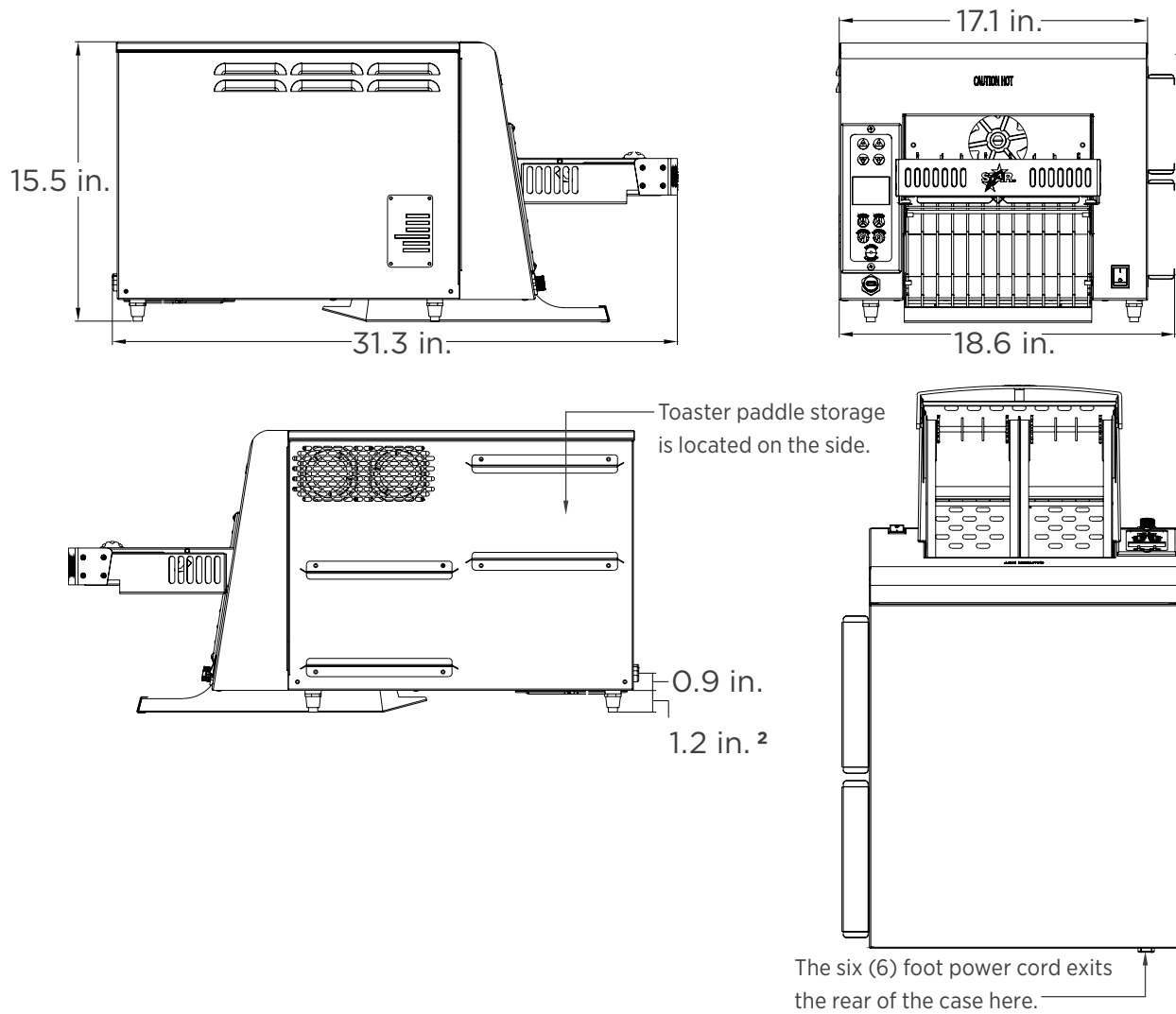

MODEL	HEIGHT in. (mm)	WIDTH in. (mm)	DEPTH in. (mm)	VOLTS	AMPS	WATTS	NEMA PLUG	APPROX. SHIP WEIGHT	APPROX. WEIGHT INSTALLED
IRCS4 ¹	15.5 (394)	18.6 (795)	31.3 (795)	208 240	22.5 19.5	4680	L6-30P 	95 lb. (43.1 kg)	80 lb. (36.3 kg)

¹ patent pending

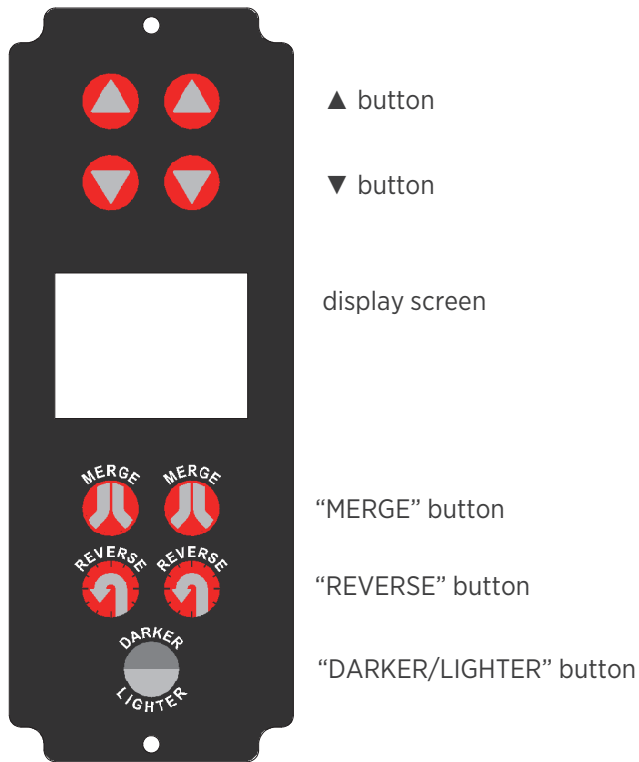

DAILY OPERATION



CERTAIN SURFACES ARE EXTREMELY HOT DURING OPERATION AND CARE SHOULD BE TAKEN WHILE USING THIS UNIT.



DO NOT LEAVE THE UNIT IN OPERATION WITHOUT AN ATTENDANT.



DO NOT LEAVE THE UNIT AT HIGH TEMPERATURE WHEN NOT IN USE OR DURING IDLE PERIODS.

START UP / PREHEAT

- i. When the toaster has been plugged into a suitable outlet and power supply, the power switch can be flipped up to turn the unit on.
- ii. The toaster will enter into its *PREHEAT* mode and a 15-minute countdown timer will appear on the screen. The fans and conveyors will turn on and the radiant elements will begin to heat up.



- iii. The unit will, by default, use the conveyor speed and heater setting last used before the previous shutdown.

MAIN MENU

- i. **DISPLAY**—Once the toaster has been pre-heated, menu products will appear in two lists on the display separated into a left and right side. The left conveyor

LEFT	RIGHT
BAGEL	CROISSANT
CROISSANT	MUFFIN
MUFFIN	FLATBREAD
LIGHT DARK	LIGHT DARK

and heaters are controlled by the left side buttons and the right side is controlled by the right side buttons.

- ii. **▲/▼ ARROWS**—The selected preset can be changed simply by pressing the ▲ or ▼ on the corresponding side until the desired preset is highlighted. The heat and speed setting change will occur instantly. Actual temperature changes in the heaters may require several minutes to adjust to the desired level.
- iii. **MERGE**—The “MERGE” buttons will cause the speed and heat settings of the two conveyors to be the same as the setting of the side that was pressed. For example, if the left “MERGE” button is pressed, the right conveyor will change its preset to match the left side’s preset. Selecting another preset will return the toaster to split operation.
- iv. **REVERSE/MELT**—The “REVERSE” button causes the conveyor to stop and the word “MELT” to flash on the screen. When the programmed amount of time has elapsed, the conveyor(s) will reverse for several seconds and then stop. The conveyor(s) will remain stopped until the “REVERSE” button is pressed again or the preset product is changed using the ▲ or ▼ buttons.
- v. **DARKER/LIGHTER**—The “DARKER/LIGHTER” button can be pressed once to activate a conveyor speed adjustment mode from the main menu. After the button is pressed, the words “DARK” and “LIGHT” at the bottom of the display will turn bright yellow indicating the function is active. The up and down arrows will cause the belt to slow down or speed up on the corresponding side allowing quick adjustments in toasting color. Selecting “LIGHT” will increase conveyor speed, while selecting “DARK” will decrease conveyor speed. Adjustments made here will stay the same until preset is changed or the unit is turned off.

SHUTDOWN

Disconnect power to the unit with the power button at the end of each day of operation. The fans may still continue to run until the toaster has completely cooled. *If the toaster must be moved after using, allow the cooling fan to turn off before unplugging.*

OTHER TOASTER FUNCTIONS

COOLDOWN MODE

COOLDOWN mode can be activated by holding the “DARKER/LIGHTER” button and the both ▼ buttons for a few seconds. *COOLDOWN* mode takes fifteen [15] minutes to complete, and causes the heaters to be turned off, but the conveyors, display, and fan to continue functioning. This mode can be used for cleaning or simply cooling off the unit.

STANDBY MODE

STANDBY mode can be activated by holding the “DARKER/LIGHTER” button and the right ▲ button for a few seconds. *STANDBY* mode causes the unit to reduce the power supplied to the heaters to 50% allowing power to be conserved during slow periods. Toasting can still be accomplished in this mode, but will take longer.

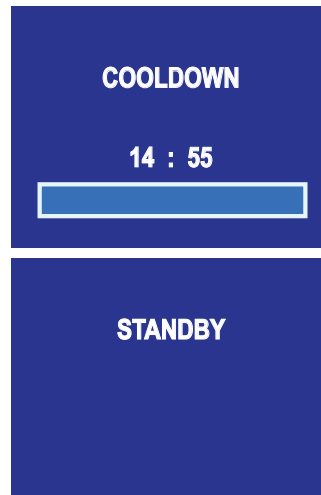

CLEANING

SUGGESTED CLEANING SUPPLIES

- i. Kay® QSR oven cleaner (degreaser)
- ii. Kay® surface sanitizer
- iii. Mild dish detergent and water
- iv. Clean cloth rag
- v. Non-scratch scour pad

CLEANING PROCEDURE

Preventive maintenance for your toaster consists of the following recommended cleaning procedures. To keep your toaster in its best operating condition, these steps should be performed on a daily, or weekly, basis as required.

- i. Turn toaster off (fans will continue to run approx. 10–15 minutes until cooled). You can also activate *COOLDOWN* mode by pressing and holding the “DARKER/LIGHTER” button and the left and right down buttons. This causes the toaster to turn off the heating elements but keep power to all other parts and the display.
- ii. Immediately spray the oven cleaner onto the non-scratch pad and scrub the conveyor chain while it is still warm and moving. **DO NOT SPRAY DIRECTLY ONTO THE CONVEYOR BELT OR INTO THE COOKING CHAMBER. OVERSPRAY ONTO THE HEATING ELEMENTS CAN DAMAGE OR SHORTEN THE LIFE OF THE ELEMENTS.**
- iii. Wash the non-scratch pad then soak with mild dish detergent. Ring the pad out so that it is only damp and continue to scrub the conveyor belt while it is still moving.
- iv. Rinse the non-scratch pad to remove all detergent and then soak with clean, warm water. Ring the pad out so that it is only damp, and continue to scrub the conveyor belt while it is still moving.
- v. Wipe the conveyor belt with a clean cloth dampened with sanitizer solution while it is still moving. Allow to air dry.
- vi. Rinse the non-scratch pad and then soak with clean warm water. Ring the pad out so that it is only damp, and wipe exterior areas of the toaster.
- vii. Wash with mild dish detergent, rinse, and sanitize removable pieces, and allow to dry before sliding the trays back into the unit.
- viii. Once dry, the unit is ready for use.



DO NOT IMMERSE THE UNIT IN WATER OR LET THE UNIT STAND IN WATER.



DO NOT USE A NON-STICK SPRAY ON THE CONVEYOR BELT, IT WILL CAUSE A STICKY BUILD-UP AND INCREASE STICKING.



DO NOT HOSE DOWN THE UNIT OR THE TABLE/COUNTER IF THE UNIT IS ON THE TABLE/COUNTER.



Press UP LEFT to upload Presets into Toaster

Press DN LEFT to copy Presets onto FLASH Drive

Remove FLASH Drive to Exit

FILES

TEST3

CTOAST

MAIN

Press L/D to select

**** TRANSFER COMPLETE ****

Remove FLASH Drive to Exit

SETTINGS AND ADJUSTMENTS

The Star IRCS conveyor toaster comes with pre-programmed factory default settings for toasting croissants, muffins, bagels, biscuits, and buns. *The default settings are set at “8” for top heat, “7” for lower heat, and “15” for conveyor speed.* User defined settings can be saved with no set limit to the variations that can be used. Users can customize product names, conveyor speed, melt time, light/dark setting, and upper, lower, left, and right heat settings.

PROGRAMMING

LOADING A PRODUCT FILE

- i. Ensure the toaster is powered on before beginning.
- ii. Plug a USB flash drive containing the desired .csv file into the receptacle.
- iii. The display will automatically search for all files with the correct .csv extension. These will then be shown on the display.
- iv. Select the desired file to upload with the right side ▲ and ▼ buttons and the “DARKER/LIGHTER” button.
- v. Programming may take up to several minutes. The display will reset when finished, and the toaster will resume normal operation.

EDIT PRODUCT SETTINGS [ON TOASTER]

THE SETUP MENU IS USED TO EDIT THE PRODUCT NAME, CONVEYOR SPEED, HEATER SETTING, OR MELT TIME FOR ANY EXISTING PRODUCTS.

- i. To access the setup menu, while on the main screen, press and hold the “DARKER/LIGHTER” button for a few seconds until the setup screen appears.
- ii. The selected product can be changed using the ▲ and ▼ buttons on the left side.
- iii. The right “MERGE” and “REVERSE” buttons are used to cycle between the other settings.
- iv. The heat settings [power 1-10], melt time [1-60 seconds], or conveyor speed [6-60 seconds] values can be changed using the right side ▲ and ▼ buttons. All values are set in whole numbers.
- v. Once finished, press the “DARKER/LIGHTER” button to exit to the main menu. Settings update instantly.

EDITING PRODUCT NAME

- i. Press the left “REVERSE” button on the product name to begin editing.
- ii. Use the right ▲ and ▼ buttons to cycle through characters and the left ▲ and ▼ buttons to move selection from character to character. Spaces cannot be used. Any characters after a space will not appear in the product name in the menu. The name can be up to a maximum of nine [9] characters.
- iii. Press the “DARKER/LIGHTER” button to save and exit.

SOFTWARE/PRODUCT UPDATE

Updates to the toaster product files can be accomplished quickly and easily through the use of the USB port located beneath the control panel. Existing product names and settings can be modified using this process as well.



DO NOT REMOVE USB FLASH DRIVE OR TURN OFF POWER UNTIL PROGRAMMING IS COMPLETE.
CAUTION TOASTER MAY NOT FUNCTION PROPERLY.

ADVANCED PROGRAMMING

CREATING A NEW UPDATE FILE

- i. If a .csv file with the correct format for uploading new preset names and settings into the toaster has not already been loaded onto a USB flash drive, a file with the correct format can be generated by plugging a USB flash drive into the toaster while it is on. *A flash drive formatted in FAT32 is strongly suggested.*
- ii. A screen will appear prompting an upload or download option for the toaster. By pressing the left-side ▼, a csv file will be generated with the toaster's current product settings and names called "TOASTDN".
- iii. Remove the flash drive and insert it into a computer with Microsoft Excel or another application capable of creating .csv files. Open the file and change the product names and settings to the desired values. Save the file as a .csv file.

FILE REQUIREMENTS

- *PRODUCT NAMES* will only appear in upper case when uploaded and must be 9 characters or less.
- *CYCLE TIME* must be a whole number between 6 and 60.
- *MELT TIME* must be a whole number between 1 and 60.
- *TOP HEATER* must be a whole number between 1 and 10.
- *BOTTOM HEATER* must be a whole number between 1 and 10.
- *FILE NAME* will only appear in upper case when uploaded, must be 8 characters or less.

POSSIBLE WARNING SCREENS

CHECK FAN

Indicates that the unit is approaching its allowable temperature limit. This is meant to be an early warning to allow the user to clear any blockages to the fan before the high limit switch trips. If clearing the blockage does not eliminate the warning after allowing a few minutes for the machine to cool, turn the unit off and contact the factory or an authorized service agency for required maintenance.

HIGH TEMP SERVICE REQUIRED

Indicates that the high limit switch has been tripped and the unit has overheated. First turn the unit off and allow it to cool. Check the lower cooling fan and clear the fan guard of any debris or blockages. Turn the unit back on and ensure warning does not appear again. If the error is still present, turn the unit off and contact the factory or an authorized service agency for required maintenance.

HEATER XX FAULT

Indicates that a heater circuit has experienced a failure and is no longer functioning. The screen will display which heater[s] have been detected with open circuits. *XX* will display the position as a two digit abbreviation [TL for top left, TR for top right, BL for bottom left, and BR for bottom right]. If resetting the power and allowing the unit to cool does not eliminate the warning, turn the unit off and contact the factory or an authorized service agency for required maintenance.

A rectangular warning screen with a red background and a yellow bar at the top containing the text "CHECK FAN" in blue capital letters.A rectangular warning screen with a red background and a yellow bar at the top containing the text "HIGH TEMP" in blue capital letters.A rectangular warning screen with a red background and a yellow bar at the top containing the text "SERVICE REQUIRED" in blue capital letters.A rectangular warning screen with a red background and a yellow bar at the top containing the text "HEATER TL FAULT" in blue capital letters.

RIGHT SIDE—ELEMENTS AND DRIVE
LEFT SIDE—PANEL

IRCS4-208 [chain and
belt not shown]

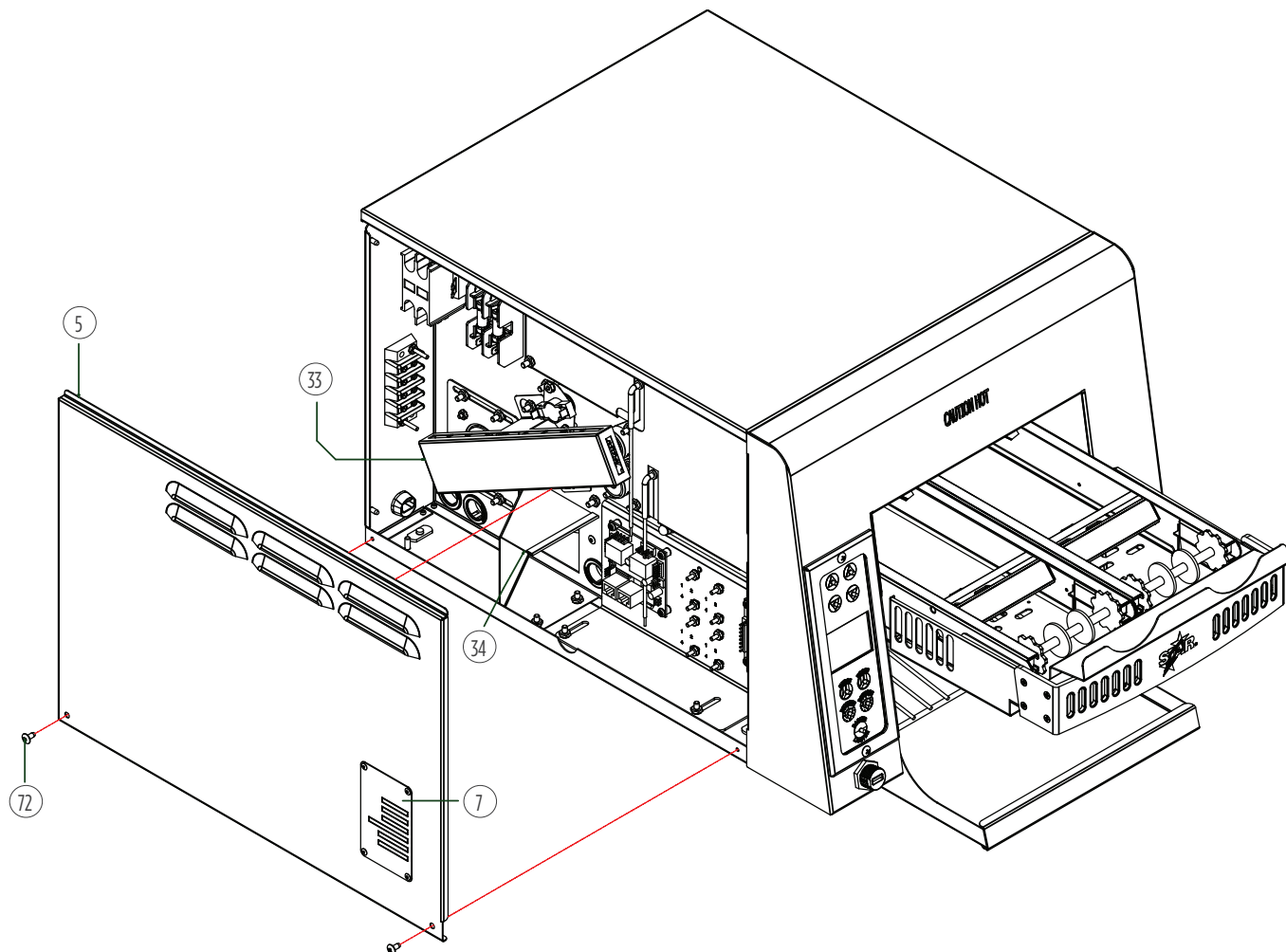
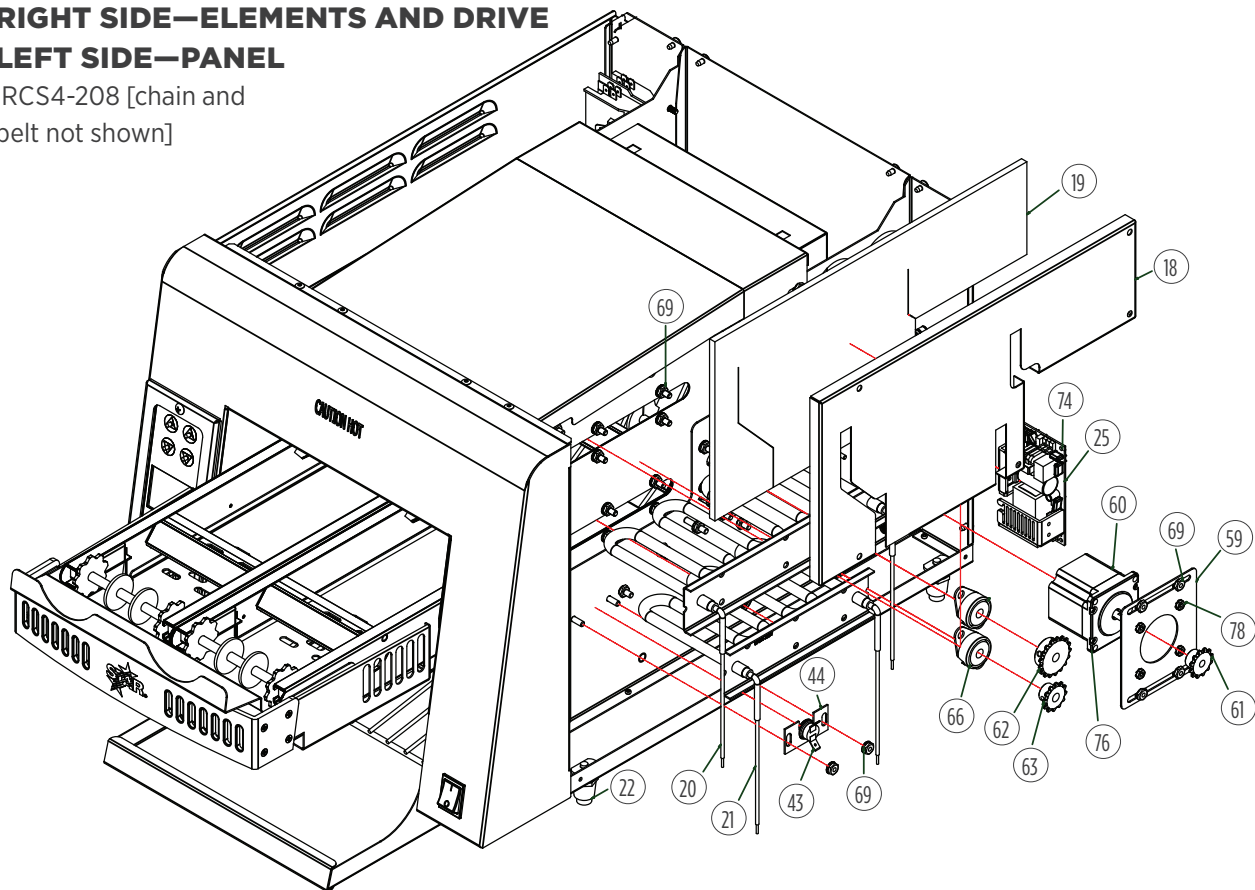

REAR—FANS FRONT, LEFT, AND TOP

IRCS4-208 [chain and belt not shown]

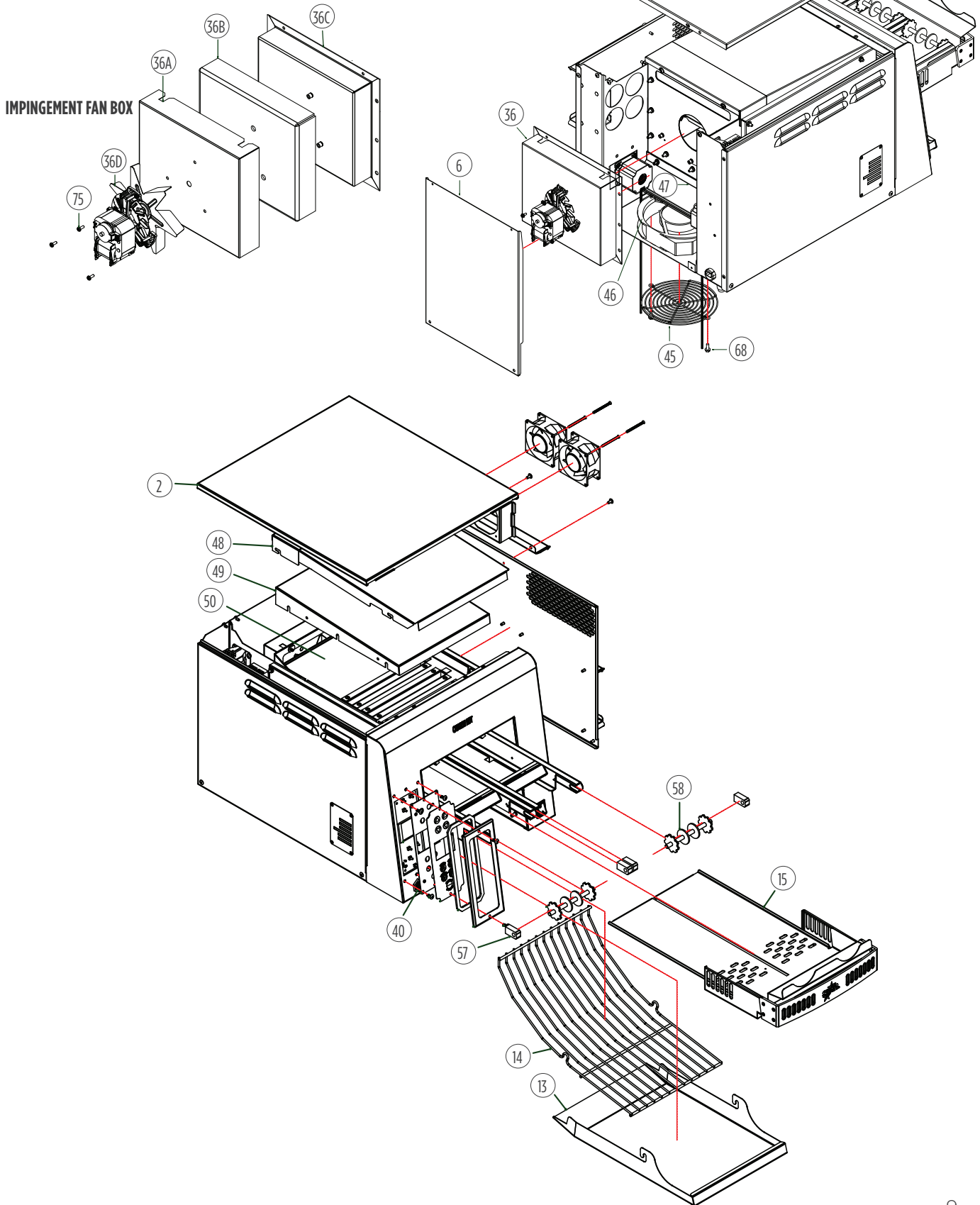

RIGHT SIDE—FANS AND PANEL CONTROL PANEL

IRCS4-208 [chain and belt not shown]

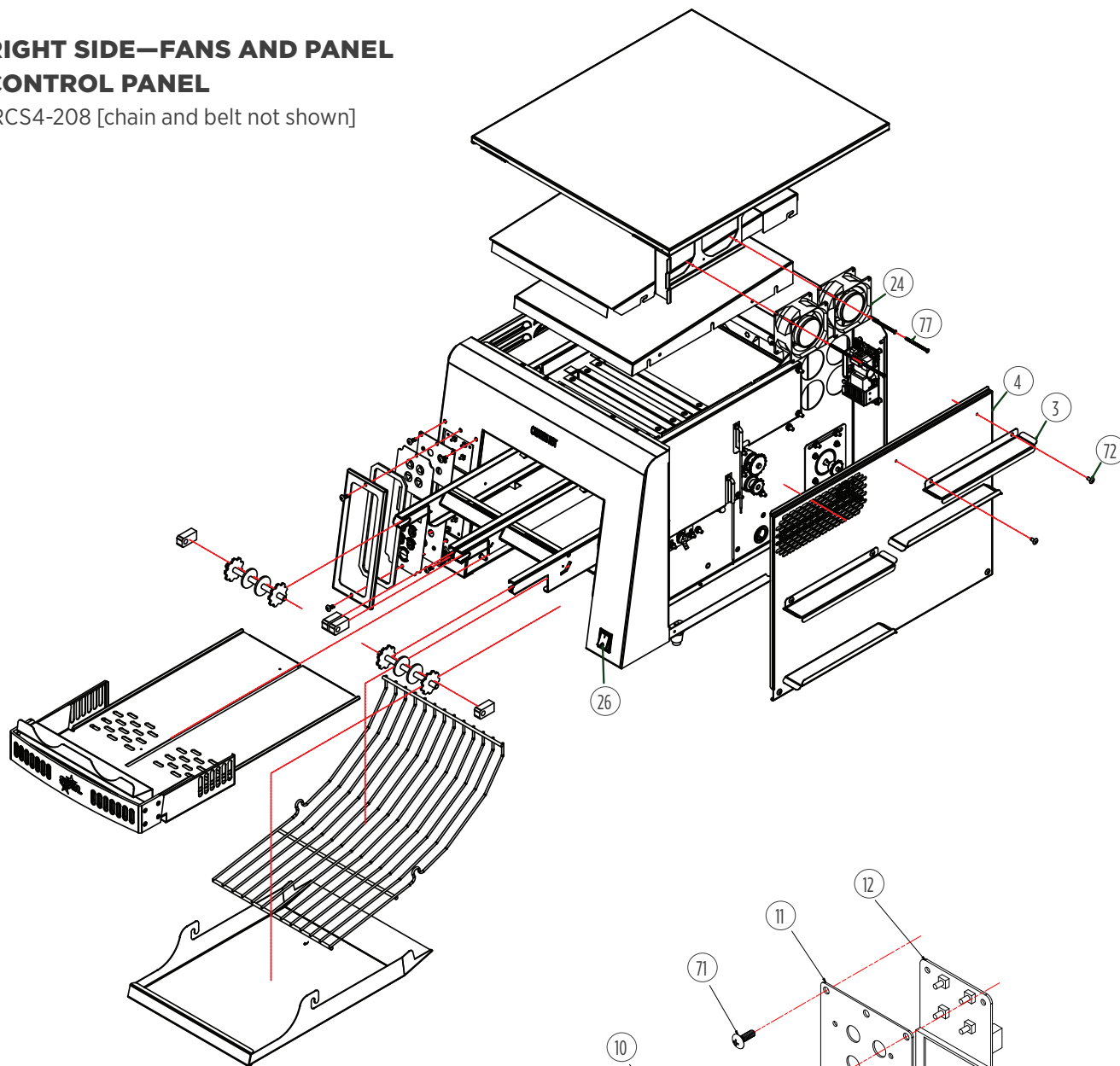

CONTROL LABEL REPLACEMENT

- i. Remove the two [2] screws holding the bezel on.
- ii. Lift off the bezel, gasket, and label.
- iii. Place new label, bezel, and gasket in place in the order displayed on the right.
- iv. Tighten down the two [2] screws that hold the bezel in place.

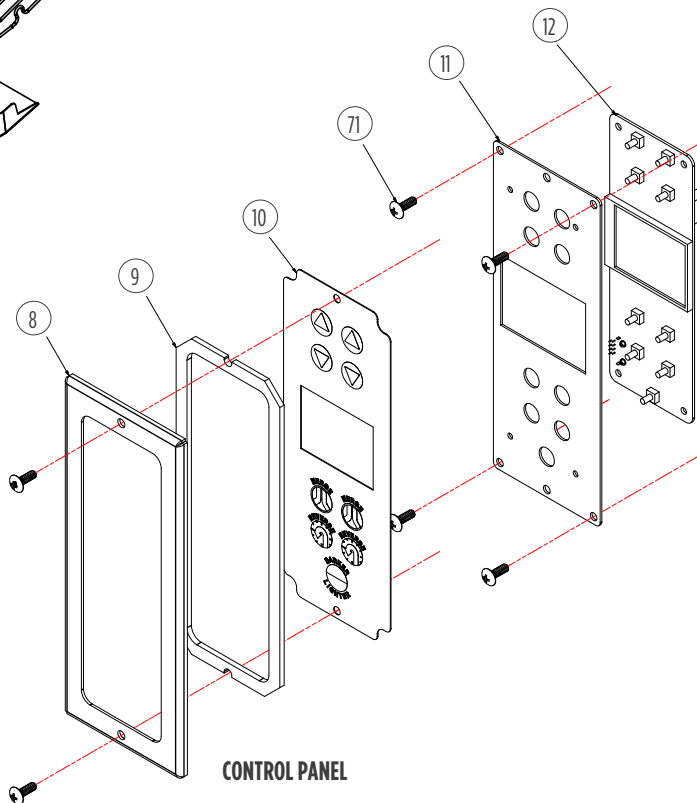

LEFT SIDE—DRIVE PARTS CONTROL BOARD

IRCS4-208 [chain and
belt not shown]

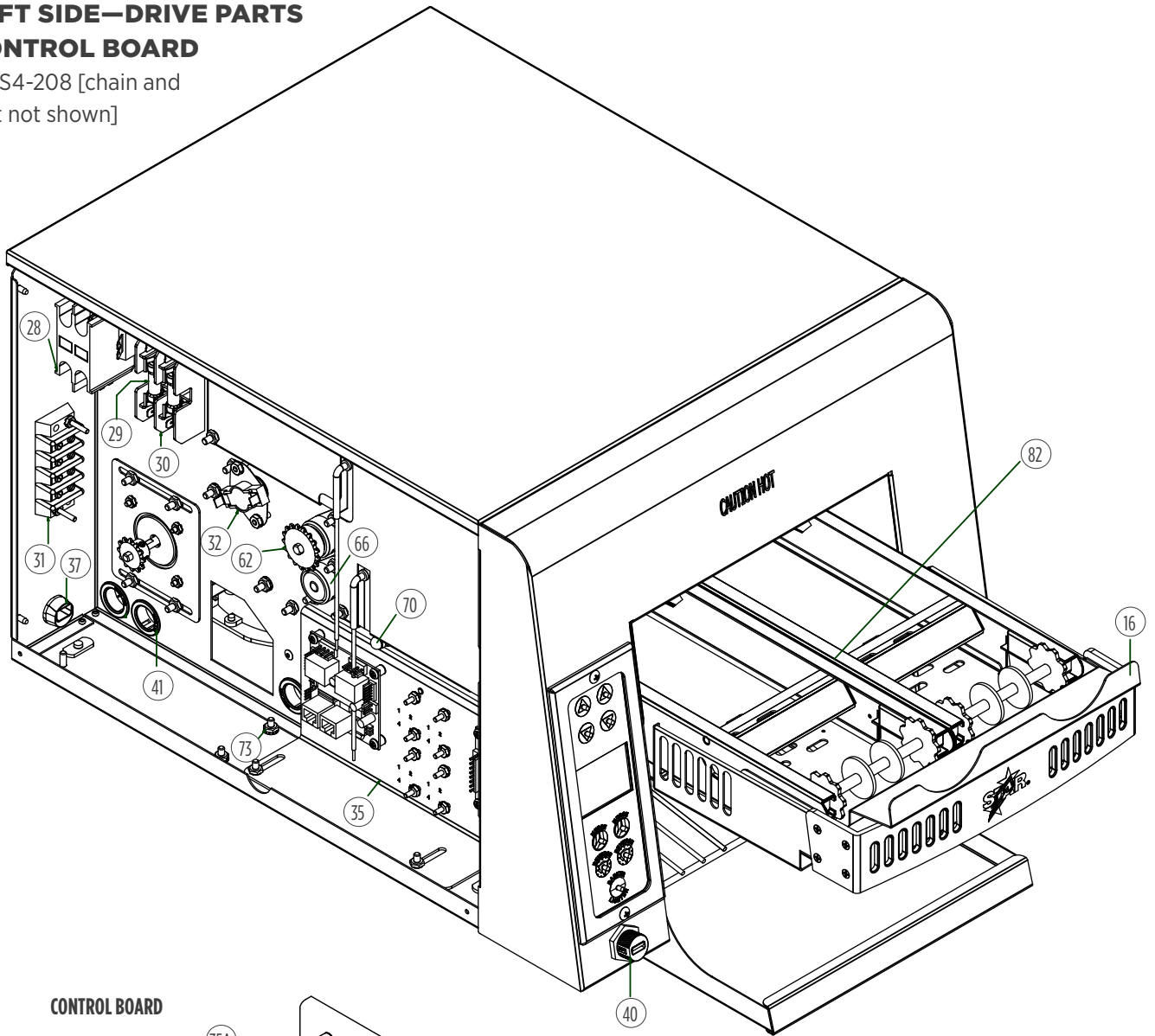

CONTROL BOARD

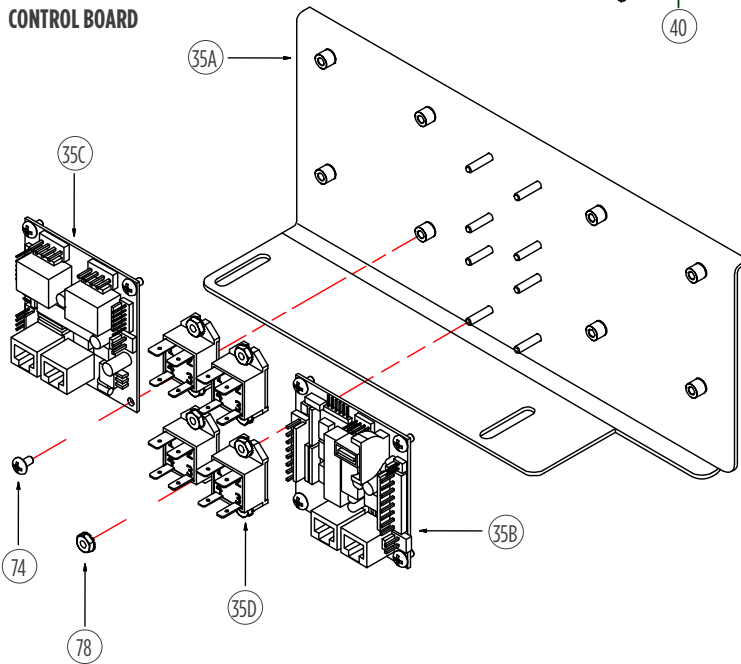

Side references are from the operator's point-of-view—from the front of the unit.
 Items labeled "NS" are non-serviceable. Items labeled "NP" are not pictured.

REF NO	PART NUMBER	DESCRIPTION	QTY	PAGE NO
1	HC-120399	chassis assembly	1	NS
2	HC-120387	cover assembly, top outer	1	9
3	HC-Z21087	paddle holder	4	10
4	HC-Z21063	cover, outer right	1	10
5	HC-Z21064	cover, outer left	1	8
6	HC-Z20896	panel, back	1	9
7	HC-Z20821	nameplate	1	8
8	HC-Z20994	bezel, control panel	1	10
9	2I-Z21052	gasket, bezel cover	1	10
10	2M-Z20982	label, control panel	1	10
11	HC-Z20995	cover, control panel	1	10
12	2E-Z20996	LCD control board	1	10
13	HC-120386	crumb tray assembly, lower	1	9
14	2B-Z20868	chute, wire rack	1	9
15	HC-120388	crumb tray assembly, upper	1	9
16	HC-Z21126	paddle stop	1	11
17	HC-Z20993	insulating panel, left	1	NP
18	HC-Z20992	insulating panel, right	1	8
19	HC-Z21029	side insulation panel	2	8
20	2N-Z21053	heating element, top	2	8
21	2N-Z21021	heating element, bottom	2	8
22	2R-200709	1-inch plastic leg	4	8
23	2V-Z20978	spacer, foot	4	NP
24	2E-Z21003	cooling fan, small	2	10
25	2E-Z21006	power supply	1	8
26	2E-Z21127	power switch	1	10
27	2E-Z21218	current sensor	1	NP
28	2E-Z21045	contactor	1	11
29	2E-Z5680	fuse	2	11
30	2E-Z5681	fuse block	1	11
31	2E-Z2894	terminal block	1	11
32	2E-Z21046	high limit reset switch	1	11
33	HC-Z21065	chain guard	1	8
34	HC-Z21059	side air guard	1	8
35	HC-120390	assembly, control mounting board	1	11
35A	HC-Z20991	control mounting board	1	11
35B	2E-Z21007	CPU board	1	11

REF NO	PART NUMBER	DESCRIPTION	QTY	PAGE NO
35C	2E-Z21008	motor board	1	11
35D	2E-Z21009	relay	4	11
36	HC-120404	impingement fan box assembly	1	9
36A	HC-Z20897	insulation holder, fan box	1	9
36B	HC-Z21012	insulation, fan box	1	9
36C	HC-120378	fan box	1	9
36D	2U-Z17519	impingement blower	1	9
37	2K-Y6764	bushing, strain relief	1	11
38	2E-Z17441	power cord set, L6-30P	1	NP
39	2E-Z21011	USB cap	1	NP
40	2E-Z21002	USB connector	1	9, 11
41	2K-Y5093	bushing	7	11
42	2C-Z13328	clamp, wire	1	NP
43	2E-200574	switch, fan	1	8
44	HG-402144	bracket, fan switch	1	8
45	2R-Z11567	guard, fan	1	9
46	2U-Z21049	cooling fan, large	1	9
47	HC-Z21055	air guide, rear	1	9
48	HC-Z20817	holder, top insulation	1	9
49	HC-Z20874	plenum, top	1	9
50	HC-120392	impingement plate assembly	1	9
51	HC-Z21068	heat shield, lower	1	NP
52	2A-Z17523	rod, heat shield	1	NP
53	2P-150015	roller chain, 20.5-inch	1	NP
54	2P-150016	roller chain, 19.5-inch	1	NP
55	2B-Z16768	wire belting, 86-inch	1	NP
56	2P-200736	bearing spring	4	NP
57	2P-200700	bearing spring, loaded	4	9
58	2A-Z16807	sprocket, idler	2	9
59	HC-Z20999	tensioner plate, motor	2	8
60	2E-Z21004	stepper motor	2	8
61	2P-Z21051	sprocket, motor	2	8
62	2P-Y4183	sprocket, drive	2	8
63	2P-200644	sprocket, scraper	1	8
64	2V-120402	rolling scraper assembly	1	NP
65	2A-Z21267	sprocket, chain drive	2	NP
66	HA-112261	PTFE bearing, bronze	4	8, 11

REF NO	PART NUMBER	DESCRIPTION	QTY	PAGE NO
67	2C-Z4063	#10-24 x 0.5-inch screw, truss head	10	NP
68	2C-Z5883	#10-24 self-threading screw	2	9
69	2C-Z6929	#10-24 keps nut	88	8
70	2C-2559	#10-24 acorn head nut	2	11
71	2C-41620	#8-32 x 0.5-inch screw, truss head	14	10
72	2C-6349	#8 X 0.375-inch sheet metal screw	20	8, 10
73	2C-Z3447	#8-32 keps nut	2	11
74	2C-200067	#6-32 x 0.25-inch screw, truss head	12	11
75	2C-1488	#6-32 x 0.375-inch screw	3	9
76	2C-200005	#6-32 x 0.5-inch screw, truss head	8	8
77	2C-Z21035	#6 x 2-inch sheet metal screw	4	10
78	2C-Z2594	#6-32 keps nut	18	8, 11
79	2C-200101	#6 split washer	3	NP
80	2C-8494	rivet, 5/32-inch x .275-inch	10	NP
81	2C-Y1451	rivet, 1/8-inch x 0.313-inch	4	NP
82	HC-120380	split-belt support assembly	1	11
83	2E-Z20918	wiring kit	1	NP

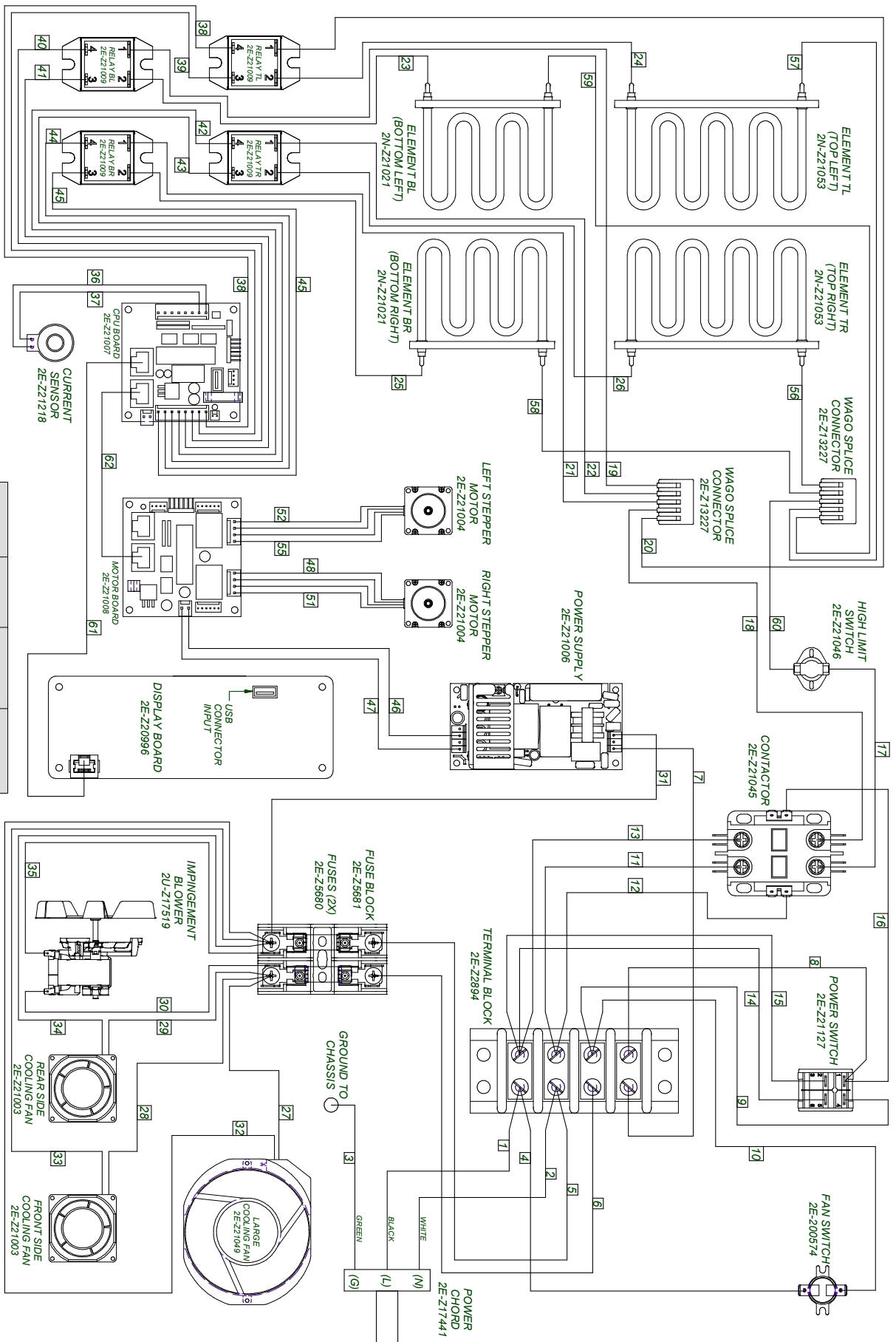

VOLTS	AMPS	WATTS	NEMA PLUG
208	22.5	4680	L6-30P
240	19.5		

STAR MANUFACTURING INTERNATIONAL INC.

10 Sunnen Drive • Saint Louis, Missouri 63143

Telephone 800 264 7827 • Fax 314 781 5445

www.star-mfg.com

Printed in the U.S.A. • ZM-ZZ1001 • Rev A • 06.2016

Specifications are subject to change without notice.