

# Unit Information

2700 Watts

Output - 1000+ Slices Per Hour

2" Opening Accommodates Thick Bread and Bagels

5-Minute Heat-Up Time



# WARING COMMERCIAL®

Conveyor Toaster

## CTS1000B /208 volt

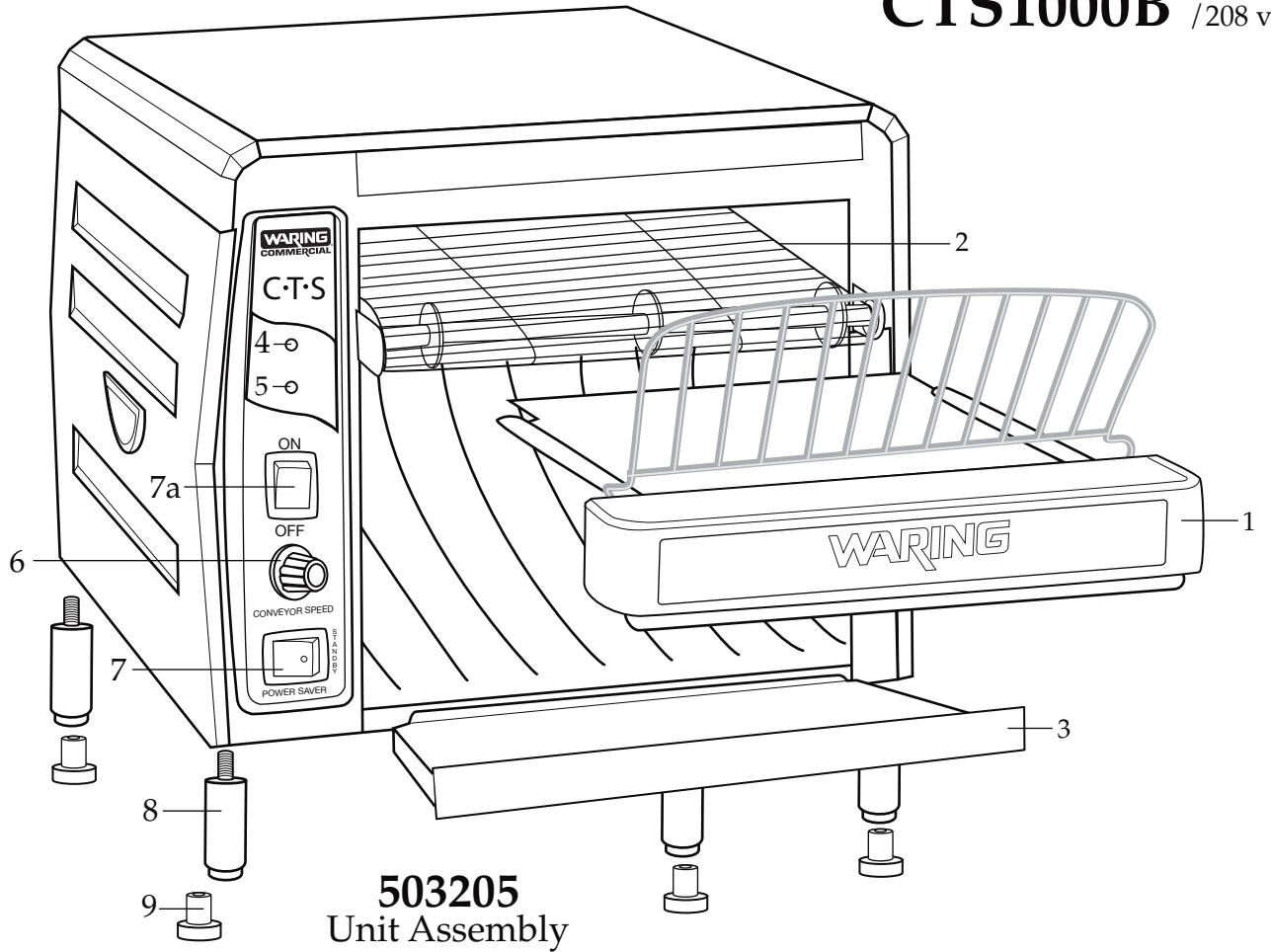

## Internal Components

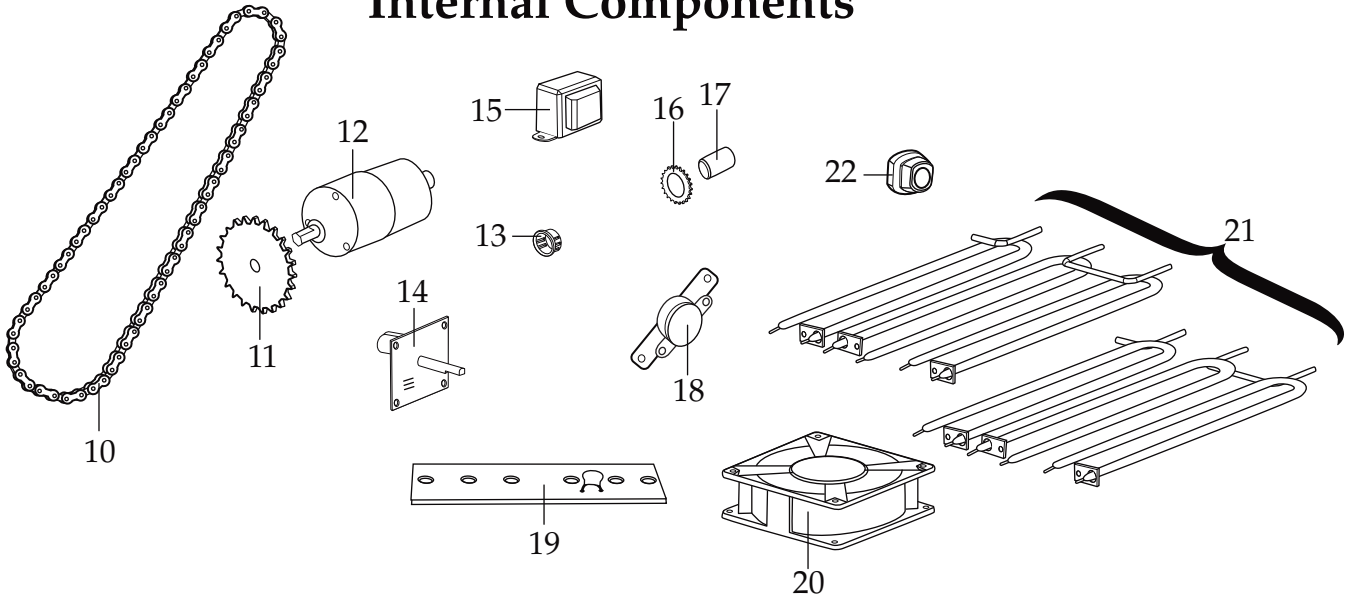

<b>Illustration #</b>	<b>Part #</b>	<b>Description</b>
1	028863	Crumb Tray
2	029683	Conveyor Belt
3	028864	Toaster Drawer
4	029684	LED Cover Red
5	029685	LED Cover Green
6	029105	Conveyor Speed Knob
7	029686	Switch - Standby
7a	029776	Switch - On/Off
8	029687	Foot Housing (4 required)
9	028865	Foot (4 required)
10	029688	Chain
11	029689	Motor Sprocket
12	029690	Motor
13	029691	Clamp Bushing (nylon)
14	029692	Main PCB Assembly
15	029693	Transformer
16	029694	Conveyor Sprocket
17	029695	Space Tube (2 required)
18	029696	Thermo Switch
19	029697	Power Connection PCB Assembly
20	029698	Fan Assembly
21	029775	Heater (set of 2 upper & 2 lower)
22	029700	Cable Clamp (strain relief)