

Churrasco/Grill Manual

Models: 2ft, 3ft, 4ft, 5ft & 6ft (with or without motor driven spits)

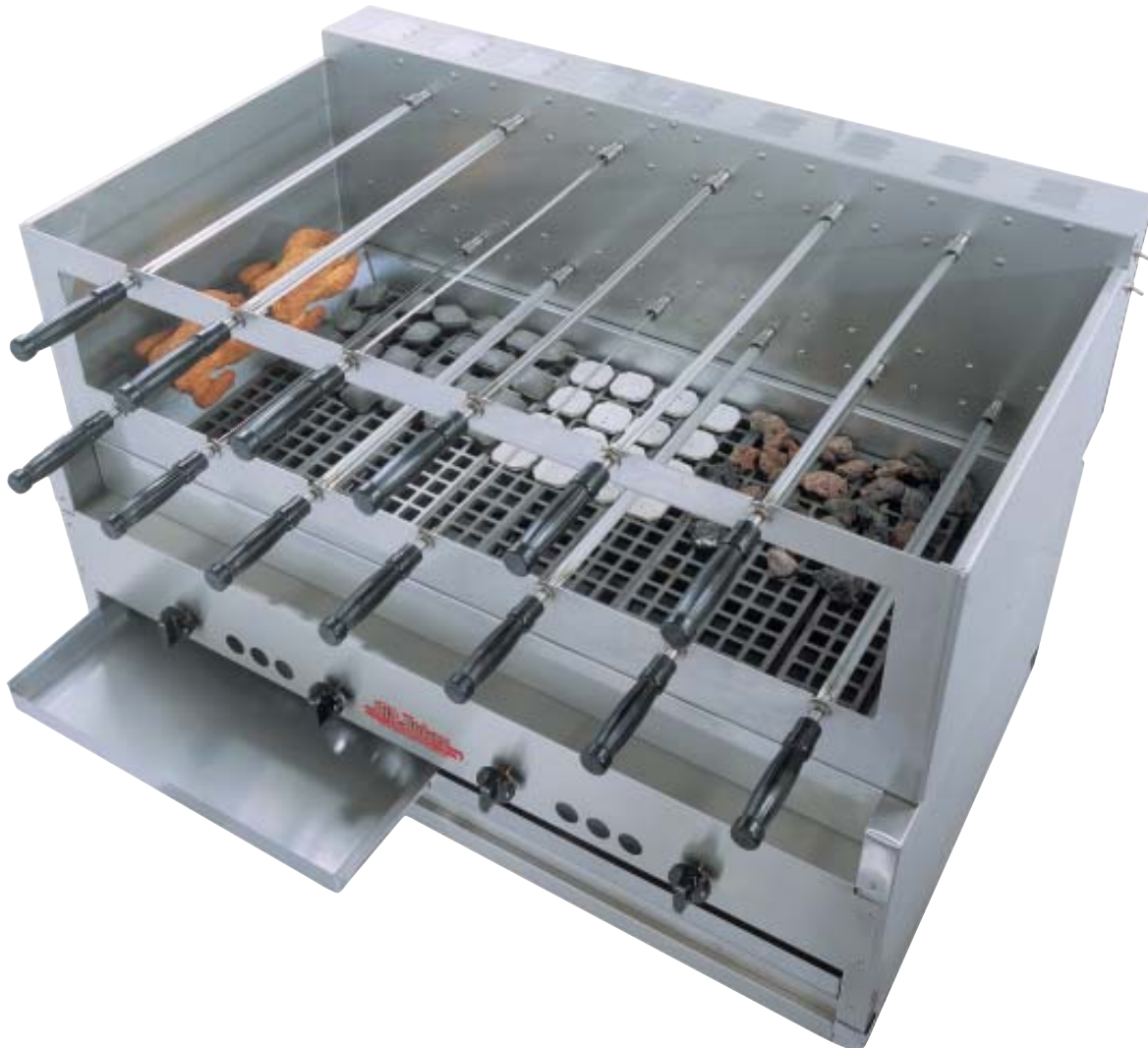

RETAIN THIS MANUAL FOR FUTURE REFERENCE

Hickory Industries, Inc.

4900 Westside Avenue, North Bergen, New Jersey 07047

Tel: 201 223-0050 Fax: 201-223-0950

(LEFT BLANK INTENTIONALLY)

Please copy, cutout and place in a prominent location.

What To Do If You Smell A Gas Odor

Natural gas is lighter than air, and it has a very high ignition temperature. For your protection, The Gas Company adds a distinctive odor to natural gas, so leaks are easily detected.

If you smell a Natural gas or a Propane gas odor:

- **DON'T panic.**
- **DON'T light a match, candle or cigarette.**
- **DON'T turn electrical appliances or lights on or off.**

For safety, a shut-off valve was installed on this appliance. If a leak occurs at this appliance, the valve will permit you to turn off the gas at the appliance rather than shutting off all gas service at the meter.

SHUT off the appliance shut-off valve.



From a safe location, call your local Gas Company 24 hours a day, seven days a week; or call **9-1-1**.

S'il vous plaît copier, découper et placer dans un endroit bien en vue.

Que faire si vous sentez une odeur de gaz

Le gaz naturel est plus léger que l'air , et il a une très haute température d'allumage . Pour votre protection, La Compagnie du Gaz ajoute une odeur caractéristique du gaz naturel , de sorte que les fuites sont facilement détectées.

Si vous sentez un gaz naturel ou une odeur de gaz propane :

- **Ne paniquez pas.**
- **NE PAS allumer une allumette , bougie ou cigarette.**
- **NE PAS tourner les appareils électriques ou les lumières ou désactiver.**

Pour plus de sécurité , une soupape d'arrêt a été installé sur l'appareil. Si une fuite se produit à cet appareil , la vanne vous permettra de couper le gaz à l'appareil plutôt que couper tous les services de gaz au compteur.

Fermez le robinet d'arrêt appareil.



D'un endroit sûr , appelez votre compagnie de gaz locale 24 heures par jour , sept jours par semaine ; ou composez le 9-1-1.

INTENDED FOR OTHER THAN HOUSEHOLD USE
OVEN MUST BE KEPT CLEAR OF COMBUSTIBLES AT ALL TIMES

IMPORTANT INSTRUCTIONS

After the gas supply has been connected to your unit, it is extremely important to check piping for possible leaks. To do this, use soap and water solutions, or solutions which are expressly made for this purpose. **DO NOT USE** matches, candles, flames, or other sources of ignitions since these methods are extremely dangerous.

In a prominent location post instructions to be followed in the event you smell gas. Obtain these instructions from your local gas supplier.

INSTRUCTIONS IMPORTANTES

Après l'alimentation en gaz a été connecté à votre appareil , il est extrêmement important de vérifier la tuyauterie pour les fuites possibles . Pour ce faire , utilisez l'eau et du savon ou des solutions , des solutions qui sont expressément à cette fin. **NE PAS UTILISER** allumettes, bougies , de flammes ou d'autres sources d' allumages puisque ces méthodes sont extrêmement dangereuses .

Dans un éminent instructions emplacement de poste à suivre en cas d'odeur de gaz . Obtenir ces les instructions de votre fournisseur de gaz local .

FOR YOUR SAFETY

Do not store or use gasoline or other flammable vapors and liquids in the vicinity of this or any other appliance.

POUR VOTRE SÉCURITÉ

Ne pas entreposer ou utiliser d'essence ou d'autres vapeurs inflammables et des liquides dans le voisinage de cet appareil ou de tout autre appareil.

WARNING

Improper installation, adjustment, alteration, service or maintenance can cause property damage, injury or death. Read the Installation, Operating and Maintenance Instructions thoroughly before installing or servicing this equipment. Initial heating of oven may generate smoke or fumes and must be done in a well ventilated area. Overexposure to smoke or fumes may cause nausea or dizziness.

ATTENTION

Une installation, un réglage, une modification , un service ou d'entretien peuvent causer des dommages matériels, des blessures ou la mort. Lire l'installation, fonctionnement et de maintenance avant d'installer ou d'entretenir cet équipement . Le chauffage initial du four peut générer des fumées ou de vapeurs et doit être fait dans un endroit bien ventilé . La surexposition aux fumées ou de vapeurs peut causer des nausées ou des vertiges.



As a safety precaution, disconnect the power supply to the appliance before cleaning or servicing this appliance.



Par mesure de sécurité, débrancher l'alimentation électrique l'appareil avant le nettoyage ou l'entretien de cet appareil.

Before lighting this piece of equipment, ensure that the ventilation hood is turned on

1. Set pilot valve with screwdriver to provide 1/2" flame by turning pilot valve counterclockwise 2. Light corresponding pilot light with a match or long match 3. After pilot lights have been lit, turn desired valve "ON".

Avant d'allumer cette pièce d'équipement , d'assurer que le capot de ventilation est activée

1. Régler la soupape pilote avec un tournevis pour fournir 1/2 " flamme en tournant la soupape pilote antihoraire veilleuse 2. Lumière correspondante avec une allumette ou long match 3. Après les lumières pilotes ont été allumés , tournez la vanne souhaitée " ON " .

NOTICE: In order to be able to service this appliance, it must be installed with the casters supplied, a connector complying with **ANSI Z21.69** or **CAN/CGA-6.16** and a quick-disconnect device complying with **ANSI Z21.41** or **CSA-6.9**. It must also be installed with restraining means to guard against transmission of strain to the connector as specified in the appliance manufacturer's instructions.

AVIS: Afin d'être en mesure de réparer cet appareil, il doit être installé avec les roulettes fournis, un connecteur conforme à la norme **ANSI Z21.69** ou **CAN / CGA- 6.16** et un dispositif de déconnexion rapide conforme à la norme **ANSI Z21.41** ou **CSA- 6.9**. Il doit également être installé avec moyens de retenue pour se prémunir contre la transmission de la souche au connecteur tel que spécifié dans les instructions du fabricant de l'appareil.

For Natural Gas: Burners are equipped with orifice spud drilled with No.30 drill size.

For LP Gas: Burners are equipped with orifice spud drilled with No. 49 drill size.



Electrical diagrams for this appliance are located behind the rear electrical box cover as well as in this manual.

Schémas électriques pour cet appareil sont situés derrière le couvercle de la boîte électrique arrière ainsi que dans ce manuel.

**ENSURE YOU DISCONNECT THE POWER
BEFORE OPENING REAR ENCLOSURE!**

**ASSURER vous débranchez le
AVANT OUVERTURE ARRIÈRE ENCEINTE !**

INSTALLATION GUIDELINES / CONSIGNES D'INSTALLATION

GAS / GAZ

Gas installation must conform with local codes, or in the absence of local codes, with the **National Fuel Gas Code, ANSI 2223.1 /NFPA 54**, or the **Natural Gas and Propane Installation Code, CSA B749.1**

installation de gaz doit être conforme aux codes locaux , ou en l'absence de codes locaux, avec le **Code National Fuel Gas , ANSI 2223,1 / NFPA 54 , ou le gaz naturel et propane Code d'installation , CSA B749.1**

ELECTRICAL INSTALLATION / INSTALLATION ÉLECTRIQUE

This appliance, when installed, must be electrically grounded in accordance with local codes, or in the absence of local codes, with the **National Electrical Code, ANSI/NFPA 70**, or the **Canadian Electrical Code, CSA C22.2**, as applicable. For your convenience, this appliance has been wired with a NEMA 5-15 cord and plug and should be plugged in to a corresponding NEMA 5-15 receptacle. The grounding prong SHOULD NOT BE CUT. **Cutting the grounding prong will void the manufacturers warranty**

Cet appareil , lorsqu'il est installé , doit être mis à la terre conformément aux codes locaux , ou en l'absence de codes locaux, avec le **National Electrical Code , ANSI / NFPA 70 , ou au Code canadien de l'électricité , CSA C22.2** , selon le cas . Pour votre commodité, cet appareil a été câblé avec un cordon NEMA 5-15 et branchez et doit être branché à un correspondant NEMA 5-15 réceptacle. La mise à la terre doit pas être coupé . **Couper la broche de terre annulera la garantie du fabricant**

PRESSURE TEST / TEST DE PRESSION

The appliance and its individual shut off valve must be disconnected from the gas supply piping system during any pressure testing of that system at test pressures in excess of $1/2$ psi (**3.5 kpa**).

The appliance must be isolated from the gas supply piping system by closing its individual manual shut off valve during any pressure testing of the gas supply piping system at test pressures equal to or less than $1/2$ psi (**3.5 kpa**).

L'appareil et son robinet d'arrêt doit être déconnecté du système de tuyauterie d'alimentation en gaz pendant les essais de pression de ce système à des pressions de test supérieures à $1/2$ psi (**3,5 kpa**) .

L'appareil doit être isolé du système de tuyauterie d'alimentation en gaz en fermant son manuel individuel robinet d'arrêt pendant tout test de pression du système de tuyauterie d'alimentation en gaz à des pressions d'essai moins de $1/2$ psi (**3,5 kpa**) égale ou .

TABLE OF CONTENTS

| | | |
|------------|--|-------------------------------------|
| 1. | INSTALLATION | 10 |
| 2. | GAS CONNECTION | 10 |
| 3. | GAS SETTINGS | 11 |
| 4. | PILOT LIGHTING INSTRUCTIONS | 12 |
| 5. | INITIAL SETUP | 12 |
| 6. | CHURRASCO COOKING | 13 |
| 7. | CLEANING AND MAINTENANCE | 13 |
| 8. | PARTS LIST | 16 |
| 9. | ELECTRICAL DIAGRAM | 17 |
| 10. | GAS CONVERSION | 18 |
| 11. | WARRANTY | (see attached warranty card) |

*KEEP THIS MANUAL FOR FUTURE REFERENCE
(CONSERVER CE MANUEL POUR FUTURE RÉFÉRENCE)*

1. INSTALLATION

Units to be installed in noncombustible locations only with 0" minimum clearance to noncombustible construction. Not approved for installations in combustible constructions.

This installation must conform with local codes. In the absence of local codes, the installation must conform with the **National Fuel Gas Code, ANSI Z223.1, Natural Gas Installation Code, CAN/CGA-B149.1**, or the **Propane Installation Code, CAN/CGA-B149.2**. Should the supply piping require pressure testing exceeding 1/2 (3.45kPa), the unit and its shutoff valve must be disconnected from the system. The units individual shutoff must be closed during any testing conducted at less than 1/2 psig.

Un-crate unit and put into place. To make the unit lighter for easier handling, remove coals (packed in boxes) and cast iron grates (these hold the coals).

Please provide a means of disconnecting the unit via a quick disconnect in case of any repairs or maintenance is required.

When installed, this appliance must be electrically grounded in accordance with local codes or in their absence of local codes, with the **National Electrical Code, ANSI/NFPA 70**, or the **Canadian Electrical Code, CSA C22.2**, as applicable.

This appliance has been plumbed for the appropriate type gas when ordered. If a conversion from Natural gas to Propane gas or Propane gas to natural gas is required, please call Hickory at 800 732-9153. We will ship you instructions and the proper orifice size. These conversions should be done in accordance to the installation guidelines and by a qualified and licensed plumber.

2. GAS CONNECTION

An adequate gas supply is imperative. Undersized or low pressure lines will restrict the volume of gas required for satisfactory performance. A steady supply pressure between 7" and 8" WC. for natural should be checked for correct gas pressure by a certified gas serviceman.

The unit should be connected **ONLY** to type of gas for which it is equipped. Check type of gas on serial plate.

- A. Attach the main shutoff valve and regulator supplied with the machine at entry of the gas manifold. Be sure regulator is connected so that the gas flow is in the same direction as the arrow on the bottom of the regulator. Using a regulator other than the one supplied with the unit will void the warranty.
- B. The manifold pressure must be maintained at the pressure marked on the serial plate: 4" WC for Natural Gas and 10" WC for Propane Gas.
- C. Use pipe joint compound which is suitable for use with LP gas on all threaded connections.

- D. Turn off all burner valves.
- E. Turn on gas supply and check all connections for leaks. Use soapy water only for testing on all gases. **NEVER** use an open flame to check gas leaks.
- F. Provisions must be made for adequate air supply.
- G. Keep area in front of unit free from obstructions which could block flow of combustion and air ventilation.
- H. Be certain that adequate clearance is maintained so that air openings in front and back unit aren't blocked, and any subsequent, necessary service can be performed. No such clearance at rear is required for gas connections and regulator, and any master shutoff valve(s) installed. Be sure there is no obstruction in front and the back.

3. GAS SETTINGS

| Type of Gas | BTU/HR Burner | Orifice Size (Drill Size) | Manifold Pressure (Inches WC) |
|-------------|---------------|---------------------------|-------------------------------|
| Natural | 45,000 | #30 | 4" |
| LP | 40,000 | #49 | 10" |

NOTE:

The flame should be 1" to 1-1/2" high on natural gas, and approximately 1/2" to 5/8" on propane gas. A soft blue flame, just short of a yellow tip gives the best results; air can be adjusted by opening or closing air shutter slightly,

Reinstall fire pot, grates and coals. Coals can be placed side by side not more than 1 layer thick, 20 pieces covering each grate. Coals are designed to leave air space between the coals, even when placed closely together. Turn flames on full for 15-20 minutes; bottom of coals should glow red.

4. PILOT LIGHTING INSTRUCTIONS

- A. Set pilot valve with screwdriver to provide 1/2" flame by turning counterclockwise.
- B. Light each pilot with match or taper.
- C. Turn desired burner valve "on".
- D. To shut down, turn burner valve "off". If pilot shuts down is desired, turn pilot valve(s) clockwise until snug.
- E. Do not attempt to relight for 5 minutes after shut down.

5. INITIAL SETUP

PROPER PLACEMENT OF COMPONENTS - It is very important that the supplied briquettes be placed in an even pattern on top of the cast iron lower grates. The grates should be placed with the flat side up. ***Do not pile on briquettes. Lava rocks or briquettes piled on more than one high will void warranty.***

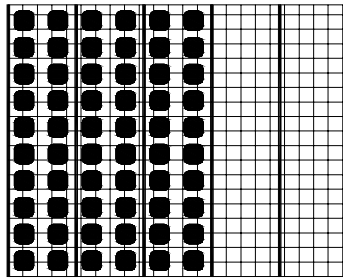

Proper Briquette Placement Shown on First Three Grates (approximately 20 briquettes per Grate)

PREHEATING - It is necessary to preheat the grill each time before cooking. The recommended time is 15-20 minutes, at which time the grill should be hot enough to cook, and will produce the proper searing effect.

FLARE-UP - A certain amount of flare-up is desirable when you are charbroiling in order to flavor your products. However, excess flare-up will burn your products and leave a bitter taste. With flare-up, there is one simple formula which holds true. The hotter the broiler and higher the product's fat content, the more flare-up you will have. Conversely, the lower the heat and lower the fat content, the less flare-up you will have.

| FLARE-UP CHART | | |
|----------------|------------------|-----------------|
| | High Fat Content | Low Fat Content |
| High Heat | High | Moderate |
| Low Heat | Moderate | Low |

6. CHURRASCO COOKING

Churrasco cooking is simply accomplished by utilizing the accompanied spits. Cut your meats or poultry into 2" * 2" * 3" pieces. Marinate them with your favorite seasonings. Overnight marinates will give you better results. Par boil your meats and then place them onto the spits. The Churrasco grill will finish off and provide the meats the "Churrasco Look". If your using any flavored briquette, charcoal or wood, the Churrasco Grill will provide great results. Be sure to cook your meats and poultry to the recommended internal temperatures.

Proper Spit Placement

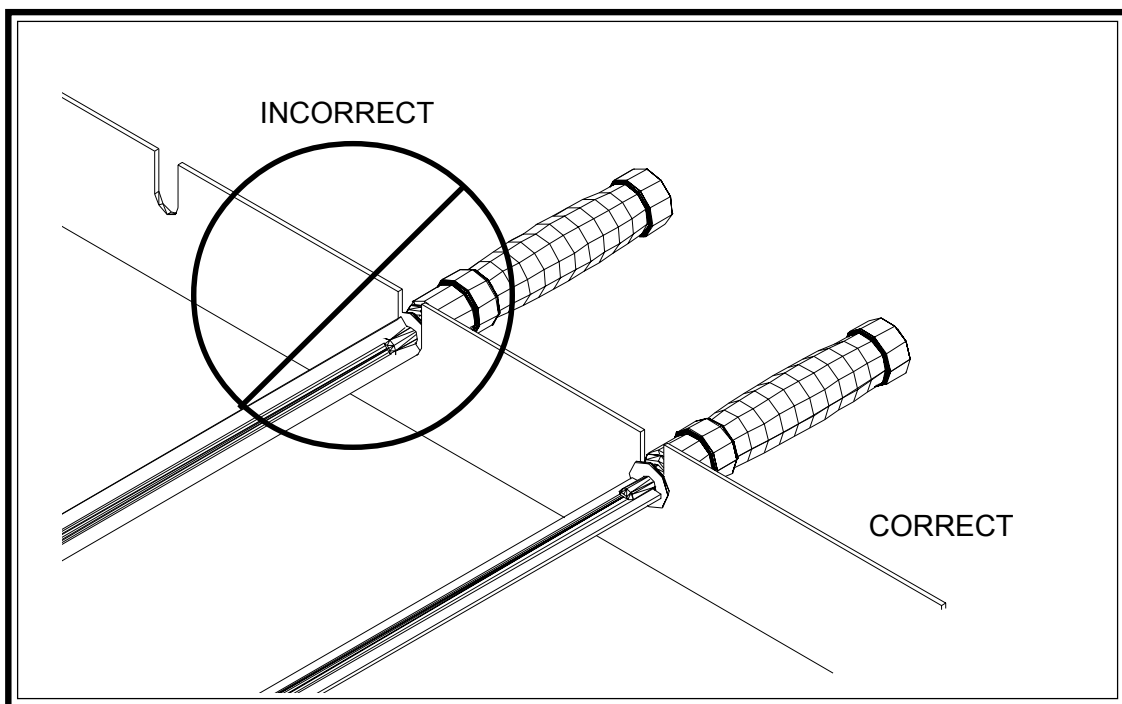

7. CLEANING AND MAINTENANCE

DAILY CLEANING AND MAINTENANCE

OUTER SIDES AND FRONT - The outer sides and front are stainless steel. Therefore, any reputable cleaner can be used to clean these surfaces. You can call Hickory for some recommendations.

INNER COOKING AREA - These surfaces are stainless steel. A paste type oven cleaner will work best to keep them clean. Be sure to remove all residue before you resume cooking operation.

LOWER TRAYS - It is recommended that the large pan be filled with 1/2" of water for easy cleaning. The water level should be checked frequently during cooking. Properly disposed the grease.

INNER PANELS - Your Churrasco has aluminized steel inside the unit. Please follow these simple rules to properly care for the aluminized finish.

1. Recommended cleaning method is to use a nylon green scrub pad and hot soapy water.
2. For more stubborn accumulations, a non-caustic, nonabrasive oven cleaner such as Easy-Off Spray Oven Cleaner Non-Caustic Formula may be used.
3. Do not use caustic cleaning compounds or oven cleaners which will harm aluminum.

DO NOT USE abrasive pads on aluminized surfaces.

Maintaining the grill in a clean, well kept fashion will prolong the life and ensure proper performance of the grill.

WEEKLY CLEANING MAINTENANCE

1. Carefully remove all ceramic briquettes and lower grates. The following "***helpful hints***" are suggested in regards to the briquettes, burner covers, and grates.

Briquettes: *Never* wash the briquettes. **Never** attempt to "self clean" the briquettes by covering while unit is in operation. To clean, simply push off any excessive residue using your thumb (we recommend you wear work gloves). When finished, replace the briquettes with the dirtier side down. The remaining residue will burn to ash. Replace any briquettes that are almost small enough to fall through the grates.

Burner Covers and Grates: When you clean the burners, make sure to rotate the covers and grates. These parts are subjected to extremely high heat and will eventually be consumed. Switch those covers and grates which are most deteriorated with those which are the least deteriorated. To clean the covers and grates, use a stiff wire brush to clear away any accumulations. These parts become brittle, so be careful not to drop them or bang them together. Burner covers and grates must be replaced periodically; it is recommended that you keep a few spares on hand. Note that parts with slight cracks or warps may still be completely functional.

2. After removing and cleaning the burner covers, brush ashes and debris off each burner. If any burner ports are clogged with grease, they can be cleared with a paper clip. Reinstall burners and burner covers.

3. Finally remove trays. Empty the contents and clean with a mild detergent in the dish area or run them through the dish machine. Put aside and allow them to dry.
4. The exterior of the broiler can be wiped clean with a damp cloth and mild detergent. On areas of grease build up, like the inner cooking area, you may need a paste type degreaser and an abrasive pad.

Your grill is now clean and ready to be reassembled in the reverse order of its break-down.

1. Replace all trays. Refill with water.
2. Replace fire pot.
3. Replace all of your grates and briquettes. Be sure that your briquettes are installed properly.

Exploded Diagram of Churrasco Unit

Note: Your unit may vary from this diagram.

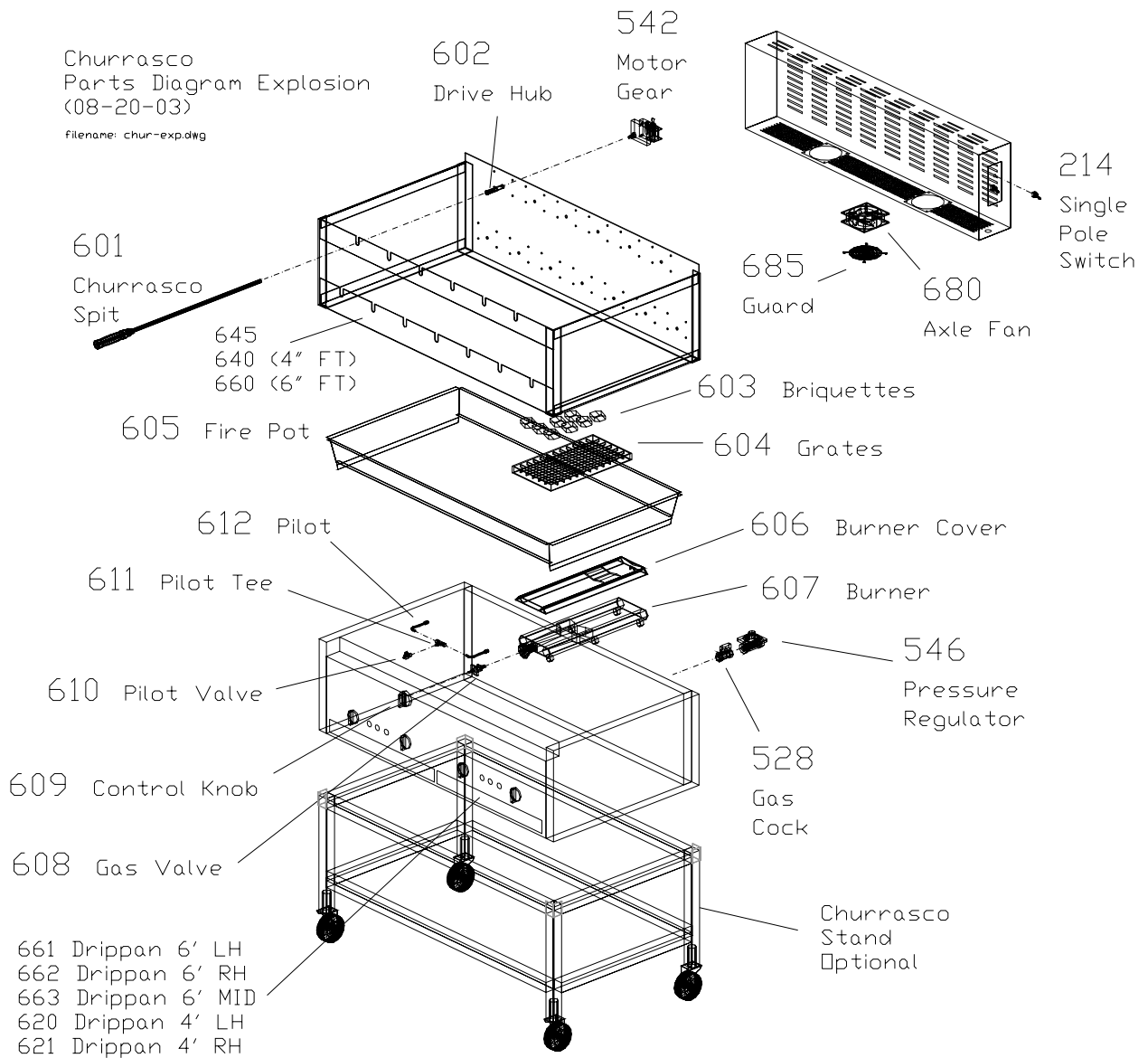

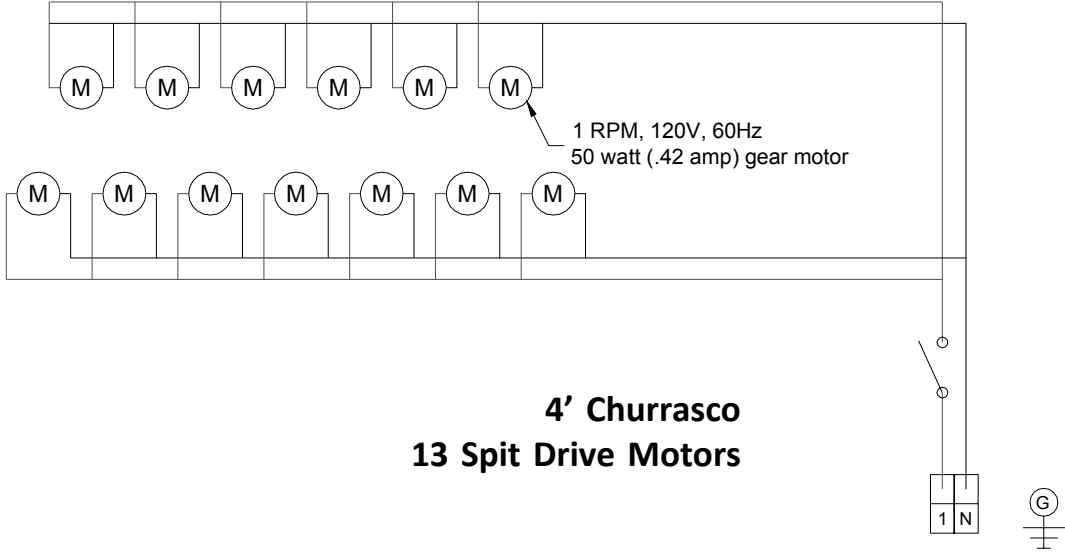

Churrasco Grill
120V, 60Hz, 6 Amp
Date: November 02, 1998

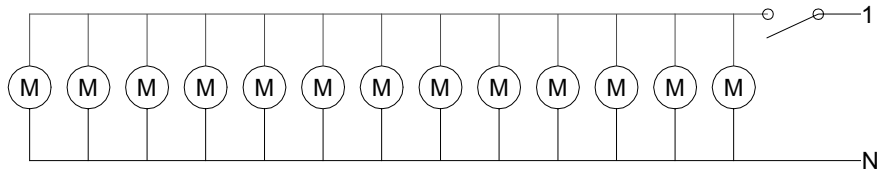

Churrasco Grill
120V, 60Hz, 6 Amp
Date: November 02, 1998

10. Conversion and Adjustment Instructions

Before converting or adjusting the machine, it is imperative that the manual gas cock be turned to the "off" position. The electrical power to the machines should also be turned off. In addition, the spring in the pressure regulator must be changed so that it can operate at higher pressures.

IMPORTANT YOU MUST WAIT 5 MINUTES BEFORE TO RE-LIGHTING UNIT
IMPORTANT VOUS DEVEZ ATTENDRE 5 MINUTES AVANT DE RE-LIGHTING UNIT

Verification for use with Natural Gas

The flame setting for each burner can be confirmed by using the volumetric method in conjunction with the main gas meter.

To carry out this verification procedure, it is necessary to obtain the heating value (BTU/ft³) of the local gas from the local gas company. **A variation in the heating value of the local gas from that on the table (1.6) will result in a variation of the power output of the unit!**

If the measured gas volume does not correspond to the values in the following table (1.6), the items which should be checked are:

- A. The incoming (connected) gas pressure while all burners and all other appliances in the location are operational.
- B. If the gas pressure is correct, it must be verified that the proper size gas orifices are in place (see page 20).

Gas Flow Table (Consumption)

| Gas | Heating Value in BTU/ft ³ | Gas Flow |
|---------|---|---|
| | | per Burner (40,000 BTU) in ft ³ /hr High Flame Setting |
| Natural | 1040 | 38.50 |
| Propane | 2500 | 16.00 |
| Butane | 2500 | 16.00 |

Volumetric Method to Verify the Flame Setting, Mathematical

WARNING! No other gas equipment can be in operation during this procedure.

ATTENTION! Aucun autre équipement de gaz peut être en service au cours de cette procédure.

Calculation of flow rate E in ft³/hour

$$Q = \frac{E}{H_i}$$

Q = Flow rate in ft³/time

E = High Flame Power setting in BTU/hr

H_i = Heating value in BTU/ft³

Thus, for natural gas:

$$Q = \frac{40,000 \text{ BTU/hr}}{1040 \text{ BTU/ft}^3} = \frac{38.50 \text{ ft}^3/\text{hr}}{1} = 0.64 \text{ ft}^3/\text{min.}$$

$$Q = 0.64 \text{ ft}^3/\text{min.}$$

Calculation of the natural gas needed in 1 hour by a 7.7G (4 burners) at full power:

$$Q = 38.50 * 4 = 154 \text{ ft}^3/\text{hr} = 2.56 \text{ ft}^3/\text{min.}$$

The time and the flow measurements should be taken at the gas (flow) meter with a chronometer (stop watch).

To run the test, open the manual gas cock valve, start up the unit according to the start-up instructions.

Allow the unit to pre-heat (burn) for 10 to 15 minutes. Verify that the flow rate is calibrated to the appropriate flow rate indicated in the table.

NOTE: This mathematical calculation was done assuming a #38 orifice size and a connected gas pressure of 5.5" with an infra-red generator. The actual flow rate will vary depending on the Heating Value of the local gas and on the set gas pressure!

Orifice Diameters, Electrode Gap Settings, and Air Intake Settings

| Gas / Pressure | Orifice Size | Electronic Ignition | |
|----------------|-----------------|--|--|
| inches W.C. | Ø in drill size | Electrode Gap | |
| Natural / 5.5" | #35 | 1/8" Between rods 1/8" Between rods and Burner surface | |
| Propane / 11" | #53 | 1/8" Between rods 1/8" Between rods and Burner surface | |
| Butane / 11" | #53 | 1/8" Between rods 1/8" Between rods and Burner surface | |

Changing Gas Orifices

1. First you will have to take out all of the inside parts in the churrasco. This will include the briquettes and grates, followed by the burner cover and burners.
2. This will give you access to the orifices. With a wrench replace each orifice with the new orifice on each burner.

