



**MODEL DFG-100-K12-ES**  
 Full-Size Convection Oven  
 Exclusively for K-12 Schools



DFG-100-K12-ES

Project \_\_\_\_\_

Item No. \_\_\_\_\_

Quantity \_\_\_\_\_

Standard depth baking compartment - accepts five 18" x 26" standard full-size baking pans in left-to-right positions.

All data is shown per oven section, unless otherwise indicated.

Refer to operator manual specification chart for listed model names.

**EXTERIOR CONSTRUCTION**

- Full angle-iron frame
- Stainless steel front, top, and sides
- Dual pane thermal glass windows encased in stainless steel door frames
- Powder coated door handle with simultaneous door operation
- Triple-mounted pressure lock door design with turnbuckle assembly
- Ball bearing slide out front control panel for easy cleaning
- 1" solid block plus 1" mineral fiber insulation for a total of 2" of insulation

**INTERIOR CONSTRUCTION**

- Double-sided porcelainized baking compartment liner (16 gauge)
- Stainless steel combustion chamber
- Single inlet blower wheel
- Five chrome-plated racks, eleven rack positions with a minimum of 1-5/8" (41mm) spacing
- Interior halogen lights

**OPERATION**

- Direct fired gas system
- Electronic spark ignition control system
- Removable inshot burners
- Internal pressure regulator
- Manual gas service cut-off switch located on the front of the control panel
- Solid state thermostat with temperature control range of 200°F (93°C) to 500°F (260°C) and LTR (linear temperature referencing)
- Two speed fan motor (single speed in CE model)
- 3/4 horsepower blower motor with automatic thermal overload protection
- Control area cooling fan

**STANDARD FEATURES**

- SSI-D - Solid state infinite control w/digital timer and LTR
- 25" (635mm) adjustable stainless steel legs (for single units)
- 6" (152mm) adjustable stainless steel legs (for double sections)
- Five year parts and labor warranty for K-12 schools only\*

\* For all international markets, contact your local distributor.

**OPTIONS AND ACCESSORIES**  
 (AT ADDITIONAL CHARGE)

- **Legs/casters/stands:**
  - 6" (152mm) seismic legs
  - 6" (152mm) casters
  - 4" (102mm) low profile casters (double only)
  - 25" (635mm) stainless steel stand w/rack guides
  - 29" (737mm) stainless steel, fully welded open stand with pan supports
- **Gas hose w/quick disconnect restraining device:**
  - 48" (1219mm) hose
  - 36" (914mm) hose
- SSI-M - Solid state infinite control w/manual timer and LTR
- Extra oven racks
- Stainless steel solid back panel
- Gas manifold (for double sections)
- Flue connector
- Direct vent

**OPTIONS AND ACCESSORIES**  
 (AT NO CHARGE)

- Solid stainless steel doors



**BLODGETT OVEN COMPANY**

www.blodgett.com • 42 Allen Martin Drive, Essex Junction, VT 05452 • Phone: (802) 658-6600 • Fax: (802) 864-0183



# DFG-100-K12-ES

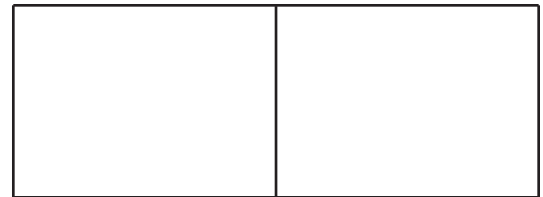

APPROVAL/STAMP

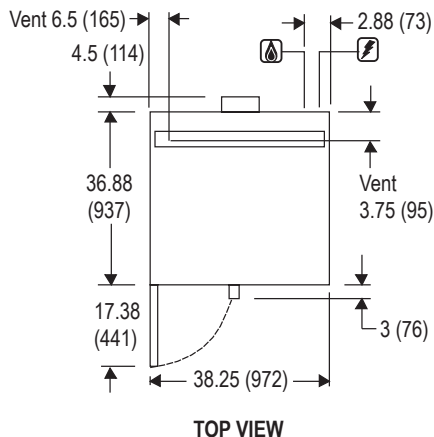

DIMENSIONS ARE IN INCHES (MM)

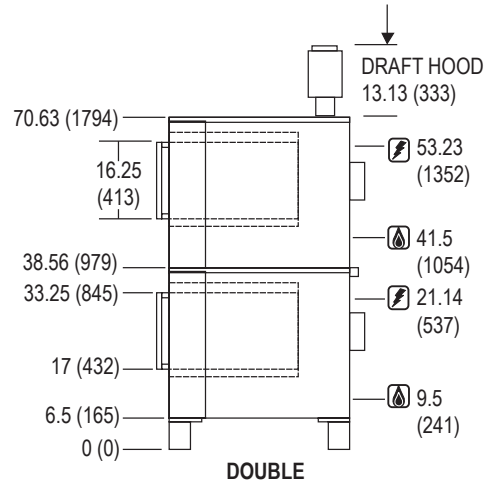
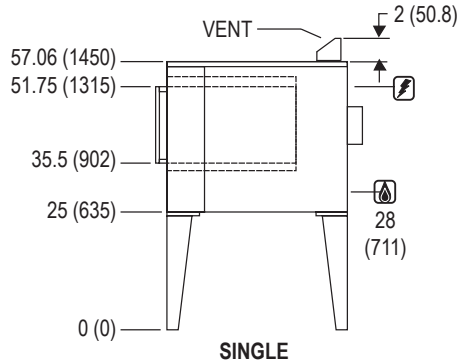

**SHORT FORM SPECIFICATIONS** - Provide Blodgett full-size convection oven model DFG-100-K12-ES, (single/double) compartment. Each compartment shall have (porcelainized/stainless) steel liner and shall accept five 18" x 26" standard full-size bake pans. Stainless steel front, top and sides. Doors shall be (solid stainless steel/dual pane thermal glass windows) with single powder coated handle and simultaneous operation. Unit shall be gas heated with electronic spark ignition and shall cook by means of a direct fired system with a gas shutoff switch on the front of the control panel. Air in baking chamber distributed by single inlet blower wheel powered by a two-speed (single speed for CE model), 3/4 HP motor with thermal overload protection. Each chamber shall be fitted with two halogen lamps and five chrome-plated removable racks. Control panel shall be recessed with solid state infinite control w/digital timer. 2014 ENERGY STAR qualified. Provide five years parts and labor warranty (K-12 only). Provide options and accessories as indicated.

### DIMENSIONS:

- Floor space** 38-1/4" (972mm) W x 36-7/8" (937mm) D
- Product clearance** 0" from combustible and non-combustible construction
- Interior** 29" (737mm) W x 20" (508mm) H x 24-1/4" (616mm) D
- If oven is on casters**
  - Single Add 4-1/2" (114mm) to all height dimensions
  - Double Height dimensions remain the same
  - Double Low Profile Subtract 2.5" (64mm) from all height dimensions

### GAS SUPPLY:

- 3/4" NPT
- Manifold Pressure: Natural – 3.5" W.C.  
Propane – 10" W.C.
- Inlet Pressure: Natural – 7.0" W.C. min. – 10.5" W.C. max.  
Propane – 11.0" W.C. min. – 13.0" W.C. max.

### MAXIMUM INPUT:

- Single 45,000 BTU/hr (13.2 Kw)
- Double 90,000 BTU/hr (26.4 Kw)

### POWER SUPPLY:

- 115 VAC, 1 phase, 8 Amp, 60 Hz., 2-wire with ground, 3/4 H.P., 2 speed motor, 1120 and 1680 RPM
- 230V CE model, 1 phase, 3 Amp, 50 Hz., 2-wire with ground, 3/4 H.P., 1 speed motor, 1425 RPM
- 6' (1.8m) electric cord set furnished on 115 VAC ovens only. Blodgett recommends a Pass & Seymour, model 2097, GFCI due to the use of a variable frequency drive. Must be hard wired in some cases.

### MINIMUM ENTRY CLEARANCE:

- Uncrated 32-1/16" (814mm)
- Crated 37-1/2" (953mm)

### SHIPPING INFORMATION:

- Approximate weight**
  - Single 590 lbs. (268 kg)
  - Double 1095 lbs. (497 kg)
- Crate size (per section)** 37-1/2" (952mm) x 43-1/2" (1105mm) x 51-3/4" (1315mm)

**NOTE:** The company reserves the right to make substitutions of components without prior notice

### BLODGETT OVEN COMPANY

www.blodgett.com • 42 Allen Martin Drive, Essex Junction, VT 05452 • Phone: (802) 658-6600 • Fax: (802) 864-0183