

E3670  
REV J 7/1/24



*The Signature of Quality®*

**FEDERAL INDUSTRIES  
LMD4878, LMD7278, LMD9678  
INSTALLATION & OPERATIONS MANUAL**



**KEEP THIS MANUAL FOR FUTURE REFERENCE**

Engineering and technical data are subject to change without notice.

FEDERAL INDUSTRIES  
Toll Free 1(800) 356-4206

P.O. Box 290  
WI Phone (608) 424-3331

Belleville, WI 53508  
Fax: (608) 424-3234

**LMD E3670**

# CONTENTS

<b>INTRODUCTION</b> .....	<b>3</b>
<b>REGISTRATION AND SERIAL NUMBER</b> .....	<b>3</b>
<b>WARNING LABELS &amp; SAFETY INSTRUCTIONS</b> .....	<b>4</b>
<b>BASE COMPONENT LAYOUT</b> .....	<b>5</b>
<b>ELECTRICAL &amp; REFRIGERATION DATA</b> .....	<b>6</b>
<b>INSTALLATION</b> .....	<b>7-19</b>
INSPECTION FOR SHIPPING DAMAGE .....	7
LOCATING THE DISPLAY CASE .....	7
REMOVING CASE FROM SHIPPING SKID .....	7
REMOVING PACKAGING MATERIAL .....	8
LIFTING AND MOVING CASE.....	8
SINGLE CASE INSTALLATION .....	9
LEVELING THE CASE.....	9
SEALING CASE TO FLOOR.....	9
MULTIPLE CASE LINEUP INSTALLATION.....	10-12
TWO CASES SINGLE REMOTE CONDENSER.....	11
FLOOR PREPERATION .....	12
JOINING AND LEVELING LINE UP .....	12-13
SEALING ALL UNITS TO FLOOR .....	13
ELECTRICAL CONNECTION .....	14-15
PERMANENTT CONNECTED.....	14
CORD CONNECTED (OPTIONAL).....	15
PANELS REMOVAL FOR ELECTRICAL ACCESS .....	16
CONDENSATE DRAIN HOSE (STANDARD).....	17
CONDENSATE PUMP (OPTIONAL) .....	17
SHELVING INSTALLATION.....	18
SHELF LIGHTS .....	19
<b>OPERATING INSTRUCTIONS</b> .....	<b>20-26</b>
CONTROL DESCRIPTION .....	20
ELECTRONIC CONTROL OPERATION.....	21-24
Button and Display Overview .....	22
Powering on Control .....	22
Adjusting the Set Point .....	23
Entering Manual Defrost Mode .....	23
Error Codes .....	23-24
Control Parameters .....	24
NIGHT CURTAIN OPERATION.....	25
SECURITY COVER INSTALLATION (OPTIONAL).....	26
<b>INITIAL START UP</b> .....	<b>27</b>
PLACING PRODUCT IN CASE .....	27
<b>MAINTENANCE</b> .....	<b>28</b>
TOP LIGHT BULB REPLACEMENT .....	28
CLEANING CONDENSER COIL .....	28
<b>DAILY CLEANING</b> .....	<b>29</b>
<b>WEEKLY CLEANING</b> .....	<b>30-31</b>
<b>MISTER OPTION</b> .....	<b>32</b>
<b>SERVICE INFORMATION</b> .....	<b>33-34</b>
SPECIAL SERVICE SITUATIONS .....	33
PRE-SERVICE CHECKLIST .....	34
<b>SALE &amp; DISPOSAL</b> .....	<b>35</b>
<b>REFRIGERATION OPERATION</b> .....	<b>36-37</b>
ELECTRONIC EXPANSION VALVE OPERATION .....	37
<b>REPLACEMENT PARTS</b> - .....	<b>38</b>
<b>WIRING DRAWING</b> .....	<b>39-41</b>
<b>OPTIONAL TOP CONDENSING UNIT INSTRUCTION</b> .....	<b>42-49</b>

---

---

# INTRODUCTION

---

---

Thank you for purchasing a Federal Industries display case. This manual contains important instructions for installing and servicing the LMD Models. A repair parts list and wiring diagrams are also included in the manual. Read all of these documents carefully before installing or servicing your case.



## NOTICE

**Read this manual before installing your case. Keep this manual and refer to it before doing any service on the equipment. Failure to do so could result in personal injury or damage to the case.**



## NOTICE

**Installation and service of the electrical components in the case must be performed by a licensed electrician.**

**The portions of this manual covering components contain technical instructions are intended only for persons qualified to perform electrical work.**



## DANGER

**Improper or faulty hookup of electrical components in the case can result in severe injury or death.**

**All electrical wiring hookups must be done in accordance with all applicable local, regional, or national standards.**

## REGISTRATION & SERIAL NUMBER

It's important to keep a record of the model and serial number of your merchandiser for warranty and part identification. Please write them here for your quick reference.

**Register your product online!** Visit our website at [www.federalindustries.com](http://www.federalindustries.com) and register your product today.

Case Model \_\_\_\_\_ Serial Number \_\_\_\_\_

We're here to provide you with the best possible experience with your new product, however, we cannot cover everything about your merchandiser in this manual, so if you have any additional questions or issues, please see the SERVICE INFORMATION PAGE to find who you should contact.

---

# WARNING LABELS & SAFETY INSTRUCTIONS

---



This is the safety-alert symbol. When you see this symbol on your case or in the manual, be alert to the potential for personal injury or damage to your equipment.

Be sure you understand all safety messages and always follow recommended precautions and safe operating procedures.



## NOTICE TO EMPLOYERS

**You must make sure that everyone who installs, uses, or services your case is thoroughly familiar with all safety information and procedures.**

Important safety information is presented in this section and throughout the manual. The following signal words are used in the warning and safety messages:

**DANGER:** Severe injury or death will occur if you ignore the message.

**WARNING:** Severe injury or death can occur if you ignore the message.

**CAUTION:** Minor injury or damage to your case can occur if you ignore the message.

**NOTICE:** This is important installation, operation, or service information. If you ignore the message, you may damage your case.

---

The warning and safety labels shown throughout this manual are placed on your Federal Industries case at the factory. Follow all warning label instructions. If any warning or safety labels become lost or damaged, call our customer service department at 1(800) 356-4206 for replacements.

---

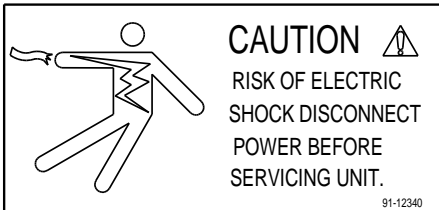

*This label is located on removable electrical panels.*

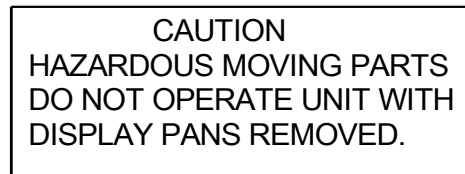

*This label is located below near moving parts*

# BASE COMPONENT LAYOUT

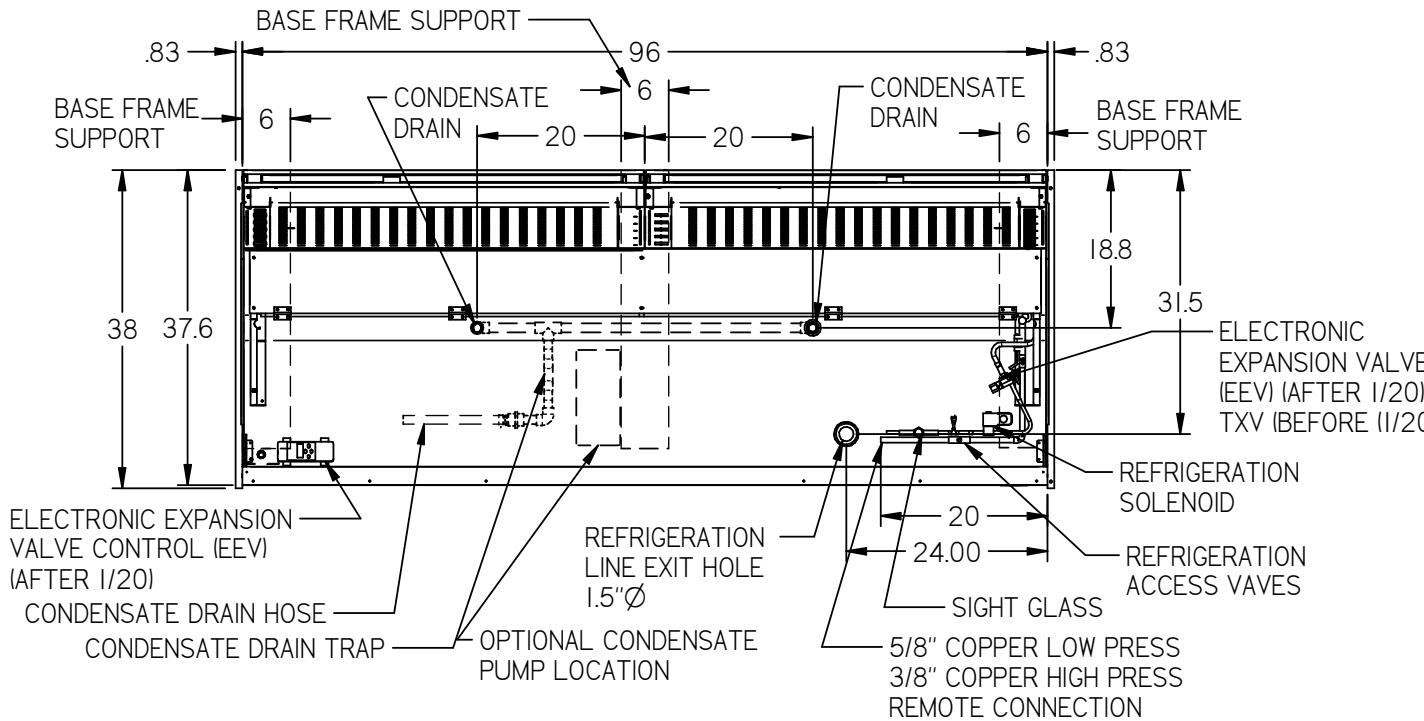
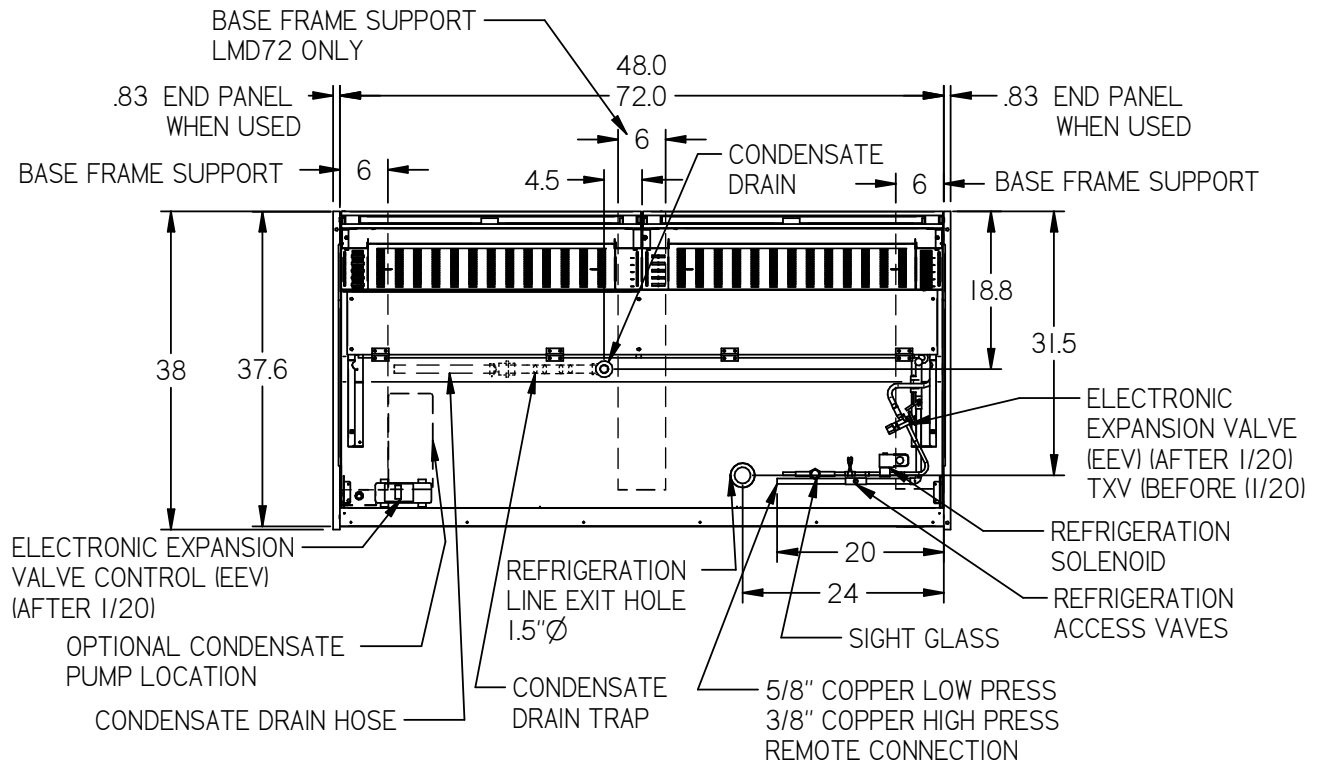

# ELECTRICAL & REFRIGERATION DATA

MODELS	LMD4878R	LMD7278R	LMD9678R
REFRIGERANT	R449A		
VOLTS	120 VOLTS		
FREQUENCY	60 HERTZ		
PHASE	1 PHASE		
# OF WIRES	3 WIRES		
EVAPORATOR FAN MOTORS	(2) .25 AMPS EA 120 VOLTS	(3) @ .25 AMPS EA 120 VOLTS	(4) @ .25 AMPS EA 120 VOLTS
LIGHT POWER SUPPLY	(2) .5 AMPS EA 120 VOLT	(2) .5 AMPS EA 120 VOLT	(4) .5 AMPS EA 120 VOLT
LIGHT BALLAST	(1) 1.0 AMPS 120 VOLT	(1) 1.0 AMPS 120 VOLT	(1) 1.0 AMP EA 120 VOLT
SOLENOID VALVE	(1).35 AMPS 120 VOLTS		
OPTIONAL CONENSATE PUMP	(1)1.5 AMPS 120 VOLTS		

Refer to the rating plate data attached to side of base for Maximum Fuse Size and Minimum Circuit Ampacity.

---

---

# INSTALLATION

---

---

## Inspection For Shipping Damage

You are responsible for filing all freight claims with the delivering truck line. Inspect all cartons and crates for damage as soon as they arrive. If damage is noted to shipping crates, cartons, or if a shortage is found, note this on the bill of lading (all copies) prior to signing.

If damage is discovered when the case is uncrated, immediately call the delivering truck line and follow-up the call with a written report indicating concealed damage to your shipment. Ask for an immediate inspection of your concealed damaged item. Crating material must be retained to show the inspector from the truck line.

## Locating The Display Case

The case(s) should be located where it is not subjected to the direct rays of the sun, heating ducts, grills, radiator, or ceiling fans, nor should it be located near open doors or main door entrances. Also, avoid locations where there is excessive air movement or air disturbances and avoid high humidity locations such as near cases with water misting or fogging devices. Failure to locate this case as stated will reduce the performance of your display and will affect temperature of interior of case and product.

If this case or cases are to be located against a wall there should be at least 6" between the case and the wall to allow air circulation. Failure to give adequate space may cause exterior surfaces to sweat.

## Removing Case From Shipping Skid

Remove the (8) 1/4" screws that secure the case to the skid. These screws are located in the front and rear Base Rails. The (4) screws in the rear base rail are easily accessible from the back of the case. To access the (4) screws in the front base rail the Front Kick panel will need to be removed.

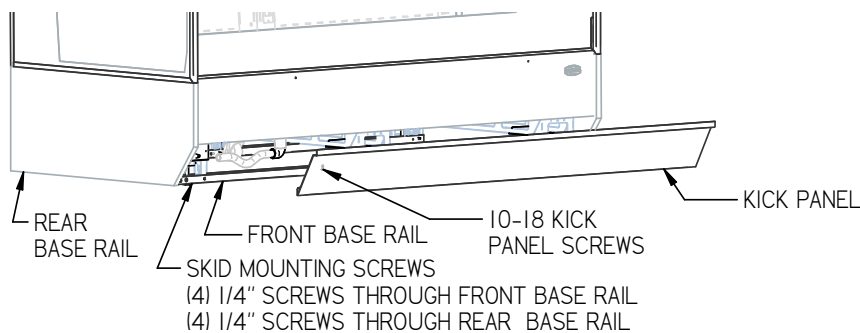

Note that the case has casters installed at factory to allow case to be moved to final location. There are leg levelers on bottom of case, once case is off skid turn the leg levelers up to allow case to roll on casters.

## Removing Packaging Material

Remove bubble wrap and packing material for all shelves and panel, brackets, etc. If it is necessary to remove tape residue from plastic materials, use cleaning compounds recommended in the cleaning section of this manual.

## Lifting and Moving Case.



**CAUTION:** Do not push or pull against the clear acrylic deflector on front of case. Doing so can cause the acrylic to break. Do not push or pull on side glass or pull on base panel. Doing so will break glass or pull out panel mounting screws. Care must be taken not to damage or tip the case when removing it from the skid or moving the case.

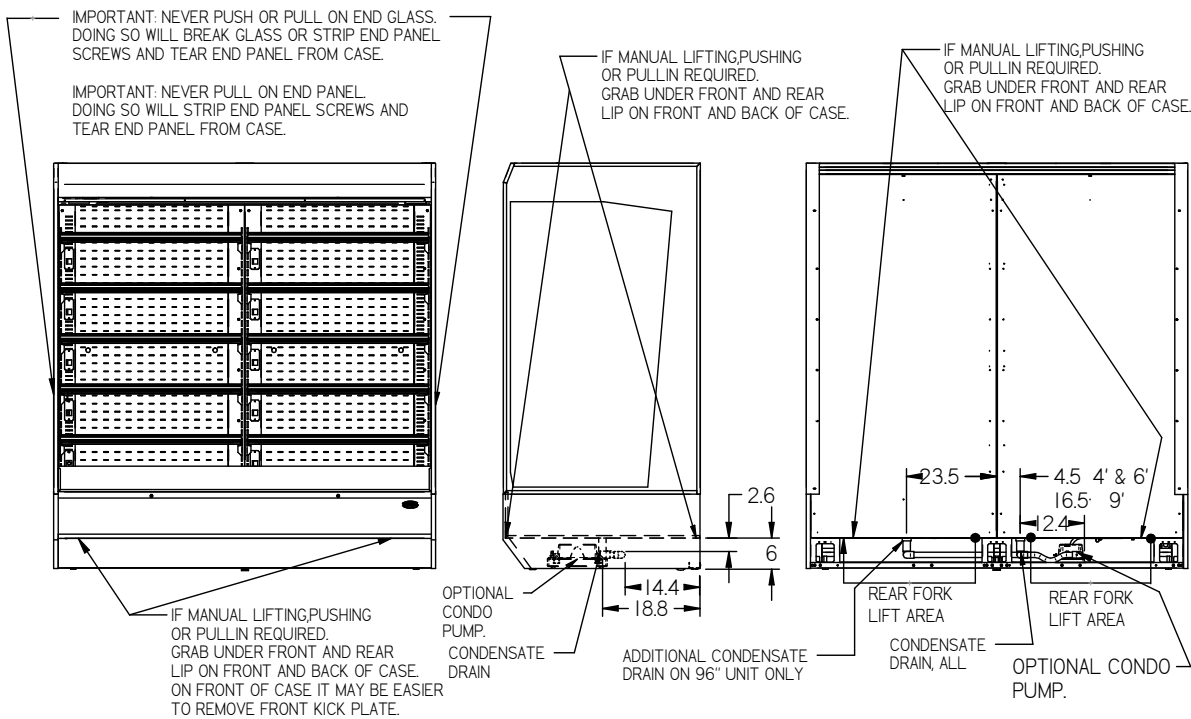

-Care must be taken when lifting and moving cases from skid as well as moving case into position.

-The case should be lifted off skid using a fork lift. The case must be lifted from rear in location noted in picture above. Be sure case is balanced equally on forks. When sliding forks under case someone must be watching that forks do not hit and damage refrigeration lines, drain or optional condensate pump.

-To prevent injury, it is not recommended to attempt lifting case manually. When lifting, pulling or pushing is required grab under front and back lip of case.

-Case is supplied with casters and once case is off of skid and on floor it should move easily into position. Light pushing on lower part of end near the base is fine. NEVER PUSH OR PULL ON GLASS. DOING SO CAN BREAK GLASS. NEVER PULL ON END PANEL OR GLASS. Doing so will strip end panel screws and tear end from case.



## **Single Case Installation**

### **Leveling the Case**

It is important that the cases are level. This will allow for proper drainage of condensate water from evaporator coil. Once the case is rolled to final location the case must be level for proper drainage of defrost water to the condensate pump. A wrench is included to aid in adjusting leg levelers

Check the level of the case along front of acrylic air deflector.

Adjust the (4) outside leg levelers as needed to **level** the case in each direction.

The LMD72 &LMD96 have (2) center leg levelers adjust these so that the center of base floor is flat.

**NOTE:** If necessary use a wood or plastic shim under each leg leveler to avoid scratching the tile floor.

### **Sealing Unit to The Floor**

After the unit is positioned and the leg levelers are turned out, the unit needs to be sealed to the floor for NSF approved installation.

# Multiple Case Lineup Installation

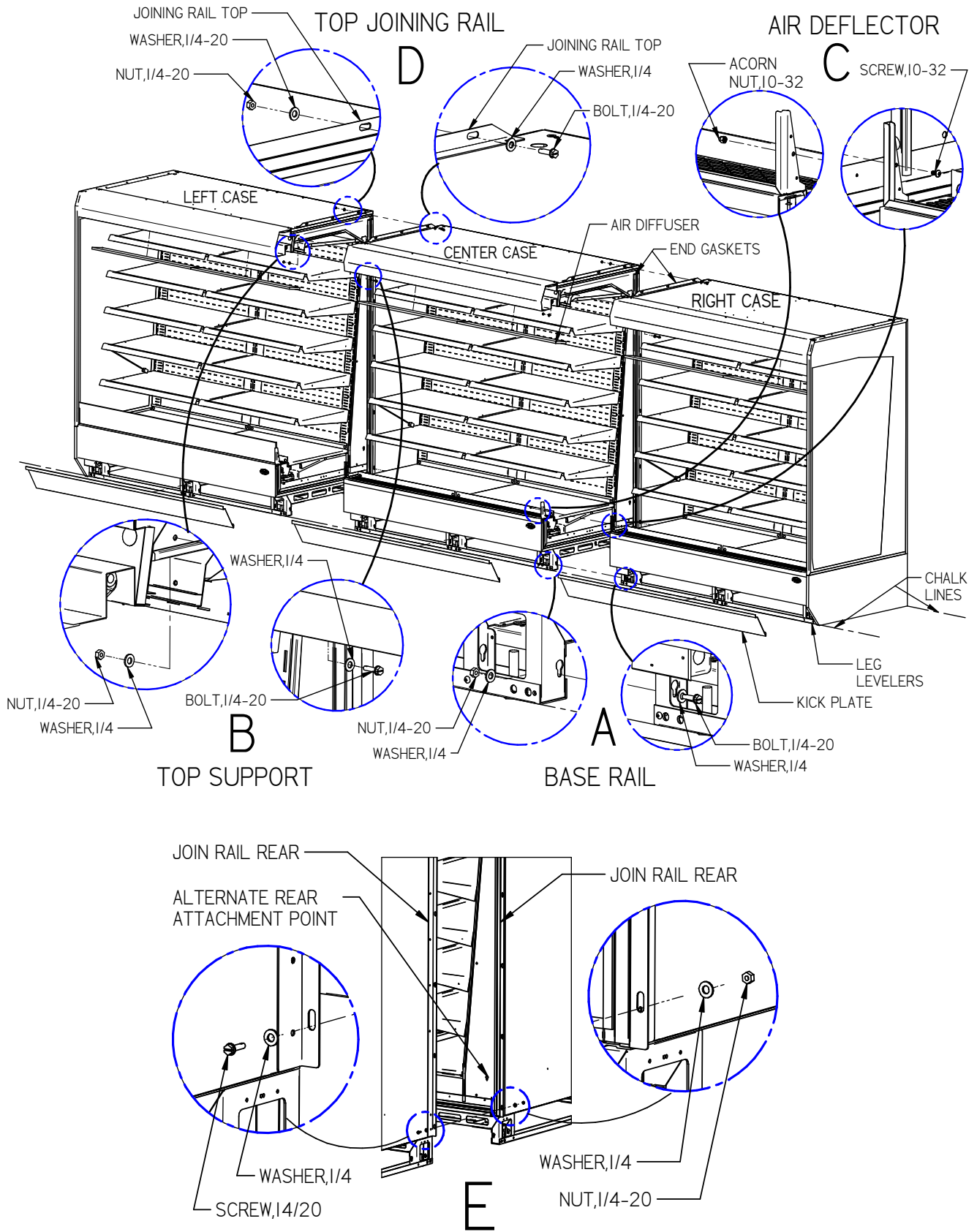

## Two Cases Connected to Single Remote Condenser

If (2) cases are ordered from factory to run on a single condensing unit, there is only one control that will operate both units.

The cases are prewired to connect both refrigeration solenoids together. These Wires are hanging out from joining side of each case near the top front behind canopy.

Once all prep work is complete and both cases are ready to be joined, connect the wires from each case together. Connect the yellow wire from case 1 to yellow wire to from case 2 and connect the white wire from case 1 to white wire from case 2.

Once connected join cases as described below. Be careful not to pinch the wires between cases.



### CAUTION:

**The refrigeration solenoid on the case that does not have a control is powered from the case that does have the control. When servicing cases disconnect power from both cases to prevent electrical shock.**



### DANGER

HIGH VOLTAGE.  
Turn power off  
before servicing.  
May have more than  
one disconnect  
switch.

"IMPORTANT"  
BEFORE INSTALLING CASES TOGETHER  
CONNECT YELLOW WIRE FROM CASE 1  
TO YELLOW WIRE FROM CASE 2.  
CONNECT WHITE WIRE FROM CASE 1  
TO WHITE WIRE FROM CASE 2.  
WHEN PLACING CASES TOGETHER DO  
NOT PINCH WIRES BETWEEN CASES.

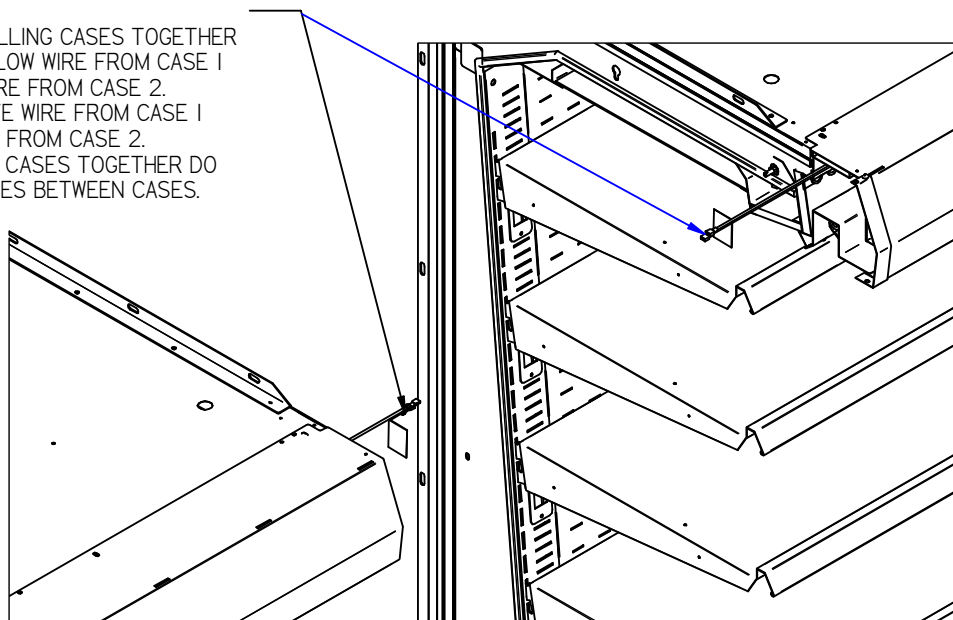

## Floor Preparation

Be sure the floor where the case line up will be located is strong enough to support cases without sagging.

It is important that the cases are level. This will allow for proper drainage of condensate water from evaporator coil and allow for proper alignment of cases.

Most floors are not level and the high and low spots in location of cases must be determined. Place a chalk line in the desired position of where the back of the cases will be located. If the back of the cases are to be along a wall there should be at least 6" clearance between wall and the back of the cases.

Measure 33.25" from this chalk line to where the front of cases will be. This line is where the front base rail meets the floor not the actual front of the case.

Mark the location along these lines that the outside edges of case will be. The cases without end panels will be 48", 72", or 96" depending on cases ordered. Add additional 1" to case end that has an end panel.

Use a transit or line level to determine the highest point along chalk line.

## Joining and Leveling Line Up

If case line up is along a wall it will make it difficult to gain access to back of case once line up is complete. If it all possible make all connections accessible from front under side of cases, but if necessary make any required connections at back of case as you install the cases.

-There are factory installed gaskets located on each end of all adjoining cases. Inspect all gaskets to be sure they are properly located and not damaged.

-Remove the front kick plates from all cases as described Panel Removal section of this manual.

-Remove all Top Air Diffuser from all cases from upper air duct track. Loosen thumb screws on Retainers located behind air diffuser. Retainer will drop down allowing diffuser to be pulled out of case.

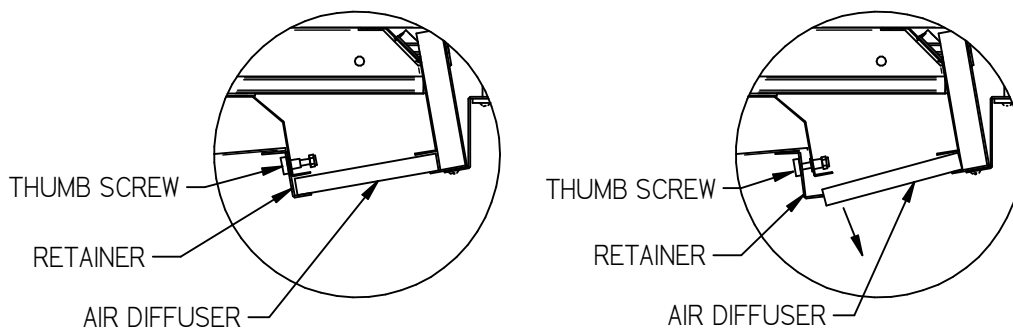

-The required fasteners to join cases are installed at the factory in the location they will be used. These fasteners are on the left side of each case. As each case is installed remove these fasteners from the case and reuse them.

-Determining highest point as described in Floor Preparation above. Install the case that will be located over the highest point first. Once the first case is rolled to final location the case must be level for proper drainage of defrost water to the condensate pump. A wrench is

included to aid in adjusting leg levelers. Check the level of the case along the ledge in front of acrylic air deflector. Adjust the (4) outside leg levelers as needed to level the case in each direction. The LMD72 & LMD96 have (2) center leg levelers adjust these so that the center of base floor is flat. If necessary use a wood or plastic shim under each leg leveler to avoid scratching the tile floor

-Place the next adjoining case into line up. Level case until case end profiles are aligned and touching. Install fasteners in the order below as designated with corresponding letter in detailed diagram. As cases are joined additional leg leveler adjustments may be necessary.

- A) Align the front of the base rail and fasten through hole in base rail using 1/4-20 bolt and 1/4-20 nut, use a 1/4 washer against each base support as shown in diagram.
- B) Align the top front of case and fasten through hole in top support using 1/4-20 bolt and 1/4-20 nut, use a 1/4 washer against each top support as shown in diagram. If necessary the top valance can be adjusted to provide better alignment. Loosen the fasteners along the top of the valance located on top of case and adjust as needed. If a perfect alignment cannot be achieved Valance Joining strap can be used only if needed. Place strap over seam and attach with self-drilling screws provided.

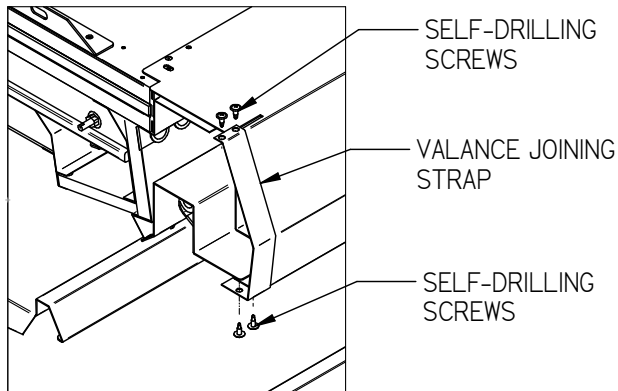

- C) Align the holes in the air deflector supports and join with 10-32 screw and 10/32 acorn nut.
- D) Align slots in top joining rail and join using 1/4-20 bolt and 1/4-20 nut, use a 1/4 washer against each top joining rail as shown in diagram.
- E) Align slots in rear joining rail and join using 1/4-20 bolt and 1/4-20 nut, use a 1/4 washer against each rear joining rail as shown in diagram. Alternate rear attachment point shown in diagram is used if it is not possible to get to back of case. Using this attachment point requires removing all shelving and slotted back panel from both cases to gain access. See appropriate section of this manual for shelf and slotted back panel removal.

Repeat for all additional cases in line up. Once all cases are attached continue with electrical, refrigeration and drain connections as described in appropriate section of this manual. Reinstall Kick Panels and air diffusers as described in appropriate section of this manual.

## Sealing all Unit to The Floor

After the unit is positioned and the leg levelers are turned out, the unit needs to be sealed to the floor for NSF approved installation.

## Electrical Connection



**DANGER:** Improper or faulty hookup of electrical components in the display case can result in severe injury or death.

### **Permanent Connected (Standard)**

- Only a licensed electrician must perform all case electrical connections.
- All electrical wiring hookups must be done in accordance with all applicable local, regional, or national electrical standards.
- A separate circuit for each display case is required to prevent other appliances on the same circuit from overloading the circuit and causing malfunction.
- The electrical service must be grounded upon installation.
- See the electrical data plate located on the inside back wall of display case, for proper circuit size and wire ampacity.

**Standard Bottom Base Electrical Connection:** Use this electrical connection when power source is from floor or wall outlet. The electrical connection box is on the bottom left side of case behind the bottom Front Kick Panel. The box is accessible by removing the Front Kick Panel. (See “Panel Removal Section” of this manual for panel removal instructions). Remove electrical box cover to access electrical connection.

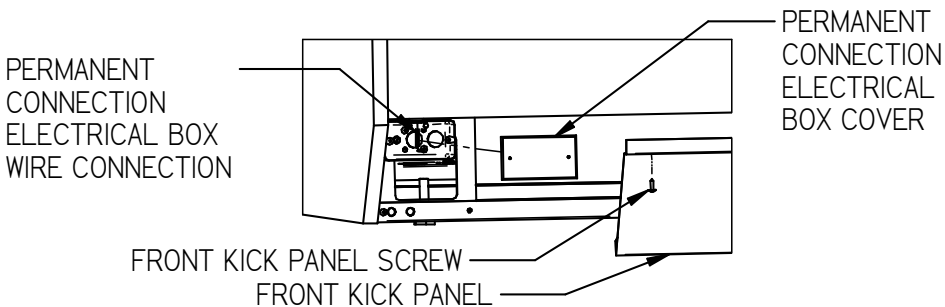

**Top Electrical Connection (OPTION):** Use this optional factory installed electrical connection when power source is from the ceiling. If equipped with this option the connection box is located on the top back left corner of case. Remove electrical box cover to access electrical connection.

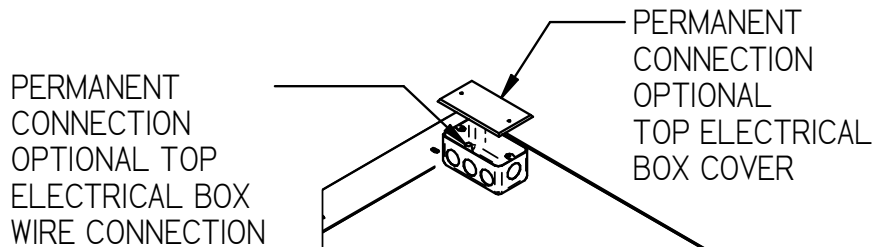

### Cord Connected (OPTION)

-A factory installed optional power cord is properly sized to the amperage requirements of the case. See the electrical data plate located on the rear exterior of the case for the proper circuit size for each case.

- The cord is can be factory installed from either the bottom base electrical box or the optional top electrical box. A separate circuit for each display case is required to prevent other appliances on the same circuit from overloading the circuit and causing malfunction.

 **CAUTION** Risk of Electric Shock. If the cord or plug becomes damaged, replace only with a cord and plug of the same type".

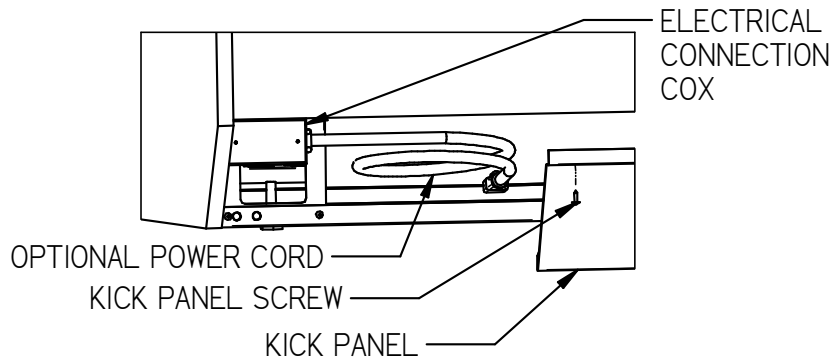

## **Panel Removal for Electrical Access**



**DANGER: Electric shock hazard. Do not operate unit with panels removed.**

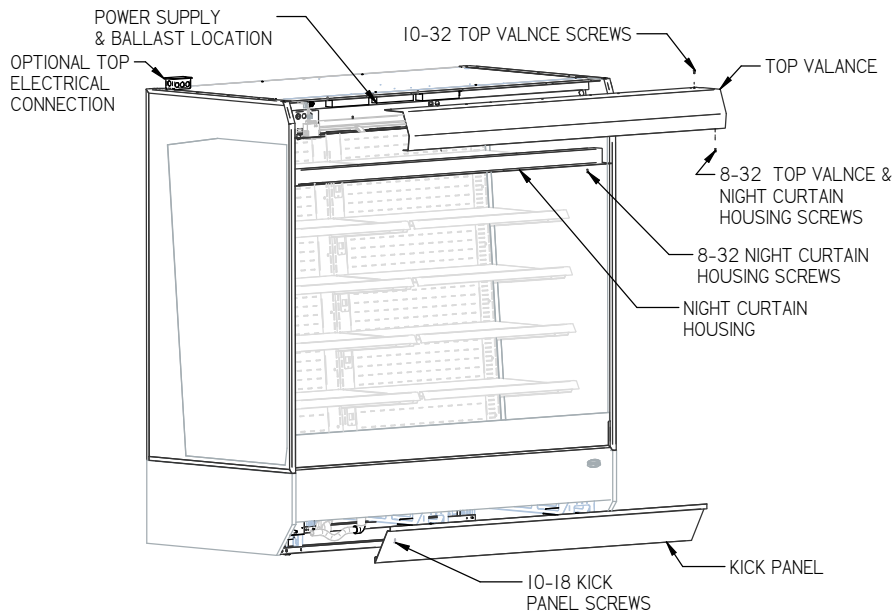

### **Kick Panels**

The kick panel located at the front base of unit can be removed to access electrical connection, condensate drain trap and hose, leg levelers and casters.

1. Loosen the 3 to 5 10-18 Kick Panel screws located under the front lip of Kick Panel.
2. Tilt the top of the Kick Panel away from the base. The bottom of Kick panel is setting on top of a frame rail and once screws are removed the Kick Panel will drop down and out of case
3. Set the Kick Panel and screws in safe place to prevent damage.
4. Reinstall Kick Panel in the reverse order.

### **Front Valance & Night Curtain Housing Removal**

The Front Valance can be removed to access all lighting ballasts, power supplies and controls. If additional access is required, the Night Curtain Housing can also be removed. The Night Curtain Housing is located directly behind the top front valance. The night curtains are housed inside

1. Remove the front (3) to (5) 8-32 screws holding the Night Curtain to the Front Valance.
2. From top of case remove the (3) to (5) 8-32 screws holding the Front Valance to top of case.
3. Carefully remove Front Valance from unit and set Front Valance and screws in safe place to prevent damage.
4. If additional access is required remove the Night Curtain Housing. Hold up on Night Curtain Housing and Remove the back (3) to (5) 8-32 Night Curtain Housing screws.
5. Set the Night Curtain Housing and screws in safe place to prevent damage.
6. Reinstall Front Valance and Night Curtain Housing in the reverse order.



### **Condensate Drain Hose (Standard)**

The case is furnished with a drain trap & 25' of drain hose. The drain hose must be run to a nearby floor drain. If draining up a slope or into a drain that is not on floor an optional pump must be used.

The drain hose is rolled up under the case for shipment. It can be accessed from the back of case and run to nearby floor drain. The drain trap and drain hose can also be accessed from front of case by removing the front Kick Panel. (See panel removal section of this manual)

Be sure not to kink or pinch hose when running drain line to floor drain.

### **Condensate Pump (Optional)**

<b>NOTICE:</b>	<b>This unit could be shipped with an optional condensate pump. The pump has a float that turns the pump on automatically when needed. The pump is mounted in the base compartment. The pump should be cleaned and inspected every 3-4 months.</b>
----------------	--

**Note: There is a piece of cardboard that has to be removed from the side of the pump to free up the float. If this is not done, the pump will not turn on and the pan will overflow.**

The case is available with an optional condensate pump. The pump is located under the case and wired to the display case electrical. It is also furnished with a drain trap & 25' of drain hose. The drain hose must be run to a drain. The pump can be accessed by removing the Kick Panel as described in the Panel Removal section of this manual.

The drain hose is rolled up under the case for shipment. It can be accessed from the back of case and run to nearby floor drain. The drain trap and drain hose can also be accessed from front of case by removing the front Kick Panel. (See panel removal section of this manual)

Be sure not to kink or pinch hose when running drain line to floor drain.

## Shelving Installation

The LMD has 5 tiers of solid metal shelves. LMD48 Models have a total of 5 shelves and the LMD72 and LMD96 shelves are split in the middle with a total of 10 shelves. Standard Shelves for each case are the same so any shelf will fit in any tier location. Some cases may be provided with optional staggered shelves meaning each shelf is a different depth. If case has optional staggered shelves the deepest shelf goes on the bottom and shallowest goes on the top.

Cases are shipped with shelves installed in the flat straight position and with the top of the bottom shelf 10.5" from top of the deck. The remaining shelves would be spaced 9.7" apart. This is a good starting shelf location and then shelf can be adjusted to suit product needs.

Follow the instruction in the illustration below. Start with the bottom shelf and determine desired shelf location. The shelves are adjustable in 1 5/8" increments and can be set in either a flat straight position or in a 10deg tilt position.

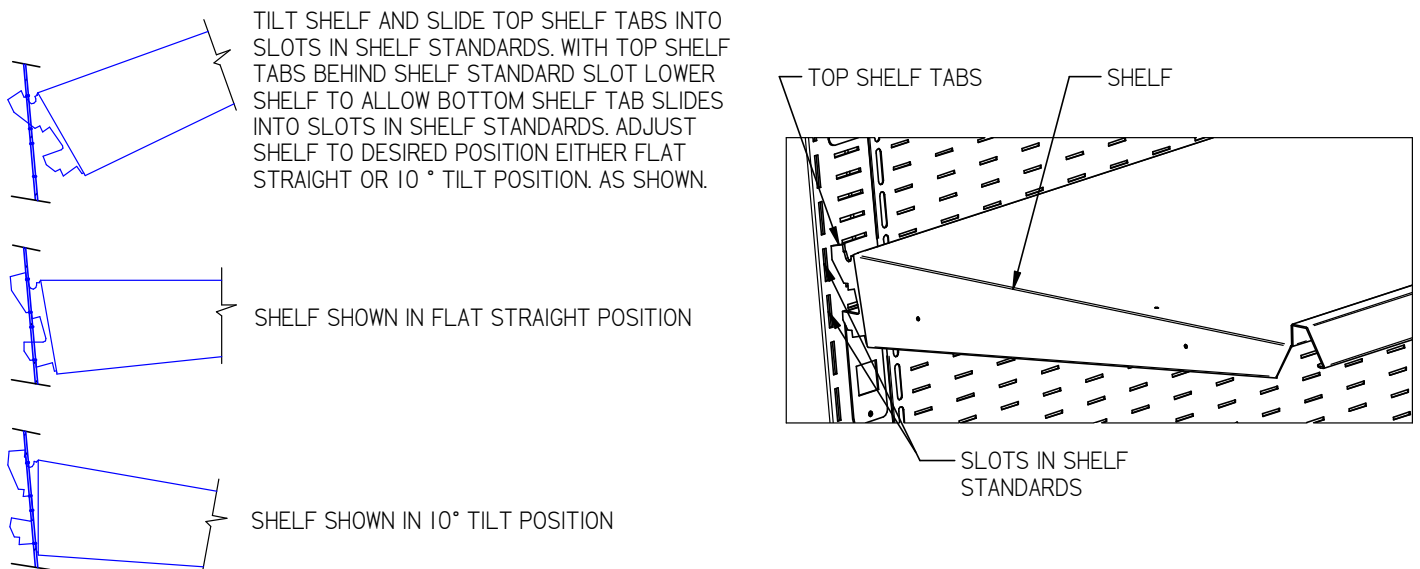

## Shelf Lights

1. The shelf lights are attached with magnets to the front underside of each shelf. Place LED Light Strip under shelf as shown and center it on shelf. The LED Light Strip plug end must be to the left side of the case.
2. Attach the Shelf Light Cord to the end of the LED light Strip as shown.

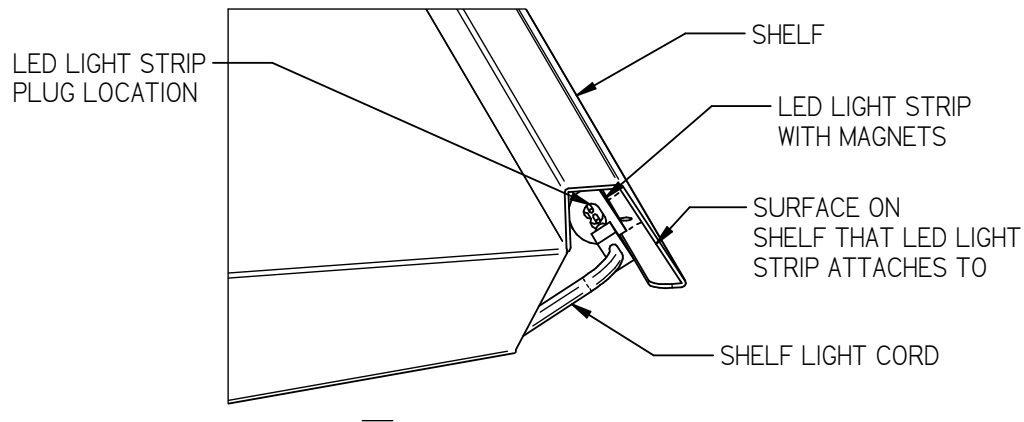

3. Remove the cap from the appropriate female light sockets. If the socket is not being used for a shelf light, the cap must be plugged into socket to prevent contamination and moisture out of the socket.
4. Plug in each shelf light by aligning the male pins on the appropriate shelf light cord plugs with the female light sockets and push together. **IMPORTANT:** Do not roll plug during insertion.
5. Hook extra cord in notch on end of shelf support and notch on back flange of shelf to keep it out of the way as shown.



---

---

# OPERATING INSTRUCTIONS

---

---



## **Control Description**

### **Light Switch**

The unit has a light switch that turns on and off the interior lights of unit.

### **Electronic Temperature Control**

Located in the rear grille of the display case, the temperature control allows the user to adjust the temperature of the display merchandiser to their needs.

## **Electronic Temperature Control Operation**

This unit is equipped with an electronic temperature control. The control parameters are set at the factory and cannot be manually changed in the field. The preset control parameters are listed on the chart in the Settings Chart below.

### **Operation**

The control uses two sensors, one located in the air stream and one located on the evaporator coil. The sensor located in the air stream is referred to as the temperature control sensor. The sensor located on the evaporator coil is referred to as the defrost probe. The temperature control sensor is located on the plastic tub behind the evaporator coil to the left in the cold air stream. The sensor location is critical for proper operation on the unit. Do not move or relocate this sensor.

The coil sensor is strapped to the evaporator coil. This sensor location is critical for proper operation of the unit. Do not move or relocate this sensor. The temperature control is set to cut in at 39°F (3.9°C). The Temp control cuts out at 26°F (-3.3°C) at the coldest setting “9” and 36°F (2.2°C) at the warmest setting “1”.

### **Defrost Cycle**



The control is programmed to initiate defrost via two different methods. There are 3 programmed defrost cycles in the case which will initiate a defrost cycle every 8 hours. The unit does not have a time clock so the defrost cycles cannot be set for any specific time of day.

The unit also has an ‘On demand’ defrost feature that will initiate a defrost when the temperature differential between the evaporator temperature and the air temperature is more than 20°F (11.1°C) for 5 minutes after 30 minutes into the refrigeration cycle (e.g. if the air stream probe measures 42°F/5.6°C or greater and the defrost probe measures 20°F/-6.7°C or lower for five minutes). Once initiated the defrost cycle will terminate when evaporator coil sensor reaches 43°F (6.1°C).

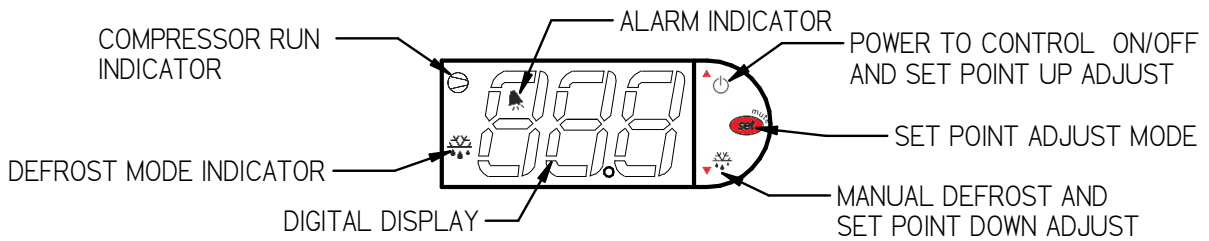

If a manual defrost is required, one can be initiated by pressing and holding the down arrow for three (3) seconds. This is typically unnecessary and should only be performed if special circumstances require it.





## Button Overview

	<p>Press and hold this button for 3 seconds to turn system on (if off) or off (if on).</p> <p>Also used to adjust set point when in set point adjust mode</p>
	<p>Press to enter set point adjust mode, confirm set point changes, and mute alarms.</p>
	<p>Press and hold this button for 3 seconds to initiate a manual defrost (and cancel defrost if initiated), also adjusts set point down when in set point adjust mode</p>



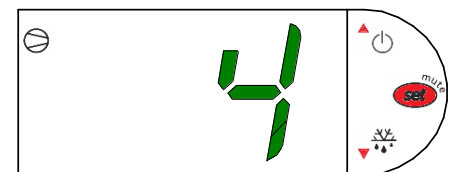
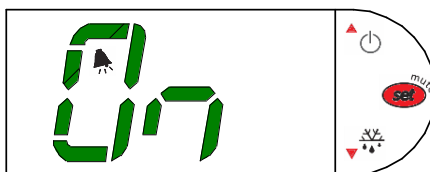
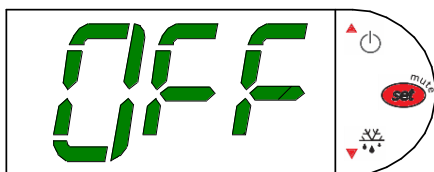

## Powering on control

To turn refrigeration control power on, press and hold  for approx. five seconds. The display will read “On” while the button is depressed. When the control powers on, the display will read the control set point of 1 thru 9. The compressor run indicator  will illuminate on the display, meaning that the compressor is running. (Note: the control may already be in the on mode when shipped from factory).

To turn refrigeration control power to off, press and hold  for approx. five seconds. The display will read “Off” while the button is depressed. When the control powers off the display will flash back and forth between the control set point and “Off”. The compressor run indicator  will be off on the display. When refrigeration control is in the off- mode cabinet lights and evaporator fans will still operate, but the compressor will not turn on causing the case to gradually reach room temperature.







## Adjusting the set point

The setpoint is what determines how cold the display case will hold food and beverage. To adjust the setpoint press and hold the  button approx. 5 seconds until the display begins to flash the set point number. Then press the use the  button to scroll number up (colder) or press the  button to scroll number lower (warmer). There are nine (9) available setpoints numbers, the higher the number of the setpoint, the colder the display case will run, with setting “9” being the coldest and setting “1” being the warmest. Once you have chosen your desired setting press the  button again to confirm your choice.



## Entering manual defrost mode

To initiate a manual, defrost press and hold the  button approx. 5 seconds. The control will read “dEF” while the button is being held. The defrost is initiated when the defrost mode indicator  illuminates on the display. The control display will then return to reading the set point. When the defrost mode indicator  turns off the defrost is complete and the compressor will turn back on illuminating the compressor run indicator .



## Error codes

It is possible for error codes to be displayed on the control screen. In the event of a malfunction an alarm will sound and the alarm indicator  will be displayed on the display. An error code or codes will flash intermittently on the display. If there are multiple codes, the display will continuously cycle through them. The following photo shows error code “E0” as an example.



**Mute:** You may mute the alarm by pressing and releasing the wrench button. The red ringing bell and all error codes will still be displayed. When the fault is remedied the control will return to normal operation and will automatically clear the codes from the display.

Error codes may be encountered if either the controller or the display case is malfunctioning. The following is a list of error codes that may be encountered.

## Error Codes and Resolutions

Code	Description	Cause	Resolution
E0	Temperature probe error	Probe signal is interrupted or short-circuited	<ol style="list-style-type: none"> <li>1. Check to ensure probe wires and quick disconnect are secure in control.</li> <li>2. Check probe resistance to table below. If 0 resistance is present check wiring insulation. If infinite resistance is present check for breaks in wiring (meter will likely read overload or very high in the mega-ohm range).</li> <li>3. Ensure that probes are wired per the wiring diagram provided.</li> <li>4. Replace probe if other remedies fail, or if probe resistance deviates from “<b>Error! Reference source not found.</b>” <b>Error! Reference source not found.</b></li> </ol>
E1	Defrost probe error	See E0	
EE	Unit parameter reading error	Operating conditions	<ol style="list-style-type: none"> <li>1. Remedy abnormal operating conditions. The control is rated to operate in a range of 14 to 122°F (-10 to 50°C) and less than 90%RH non-condensing.</li> <li>2. Replace control if problem persists.</li> </ol>
EF	Operating parameter reading error	See EE	

### Temperature Probe Common Resistance Chart

Probe Temp	Maximum Resistance [Ω]	Normal Resistance [Ω]	Minimum Resistance [Ω]
32°F (0°C)	27.83	27.28	26.74
77°F (25°C)	10.1	10	9.9
212°F (100°C)	1	0.97	0.94

### CONTROL PARAMETERS LMD

Parameter Description									
Control Setpoint →	1	2	3	4	5	6	7	8	9
Compressor Cut out [°F]	34.0	32.7	31.5	30.2	29.0	27.7	26.5	25.2	24.0
Compressor Cut in [°F]	39.0°								
Compressor Min On Time	5 min								
Compressor Min Off Time	2 min								
Compressor Max Run Time	60 min								
Defrost Termination Temp [°F]	45.0								
Time to first defrost	6 hr.								
Time to subsequent defrost	6 hr.								
Maximum Defrost duration	30 min								
Defrost on demand differential [°F]	25.0								
Delay for defrost on demand	5 min								
Time delay to the next defrost on demand	30 min								



## **Night Curtain Operation**

Night curtains are standard on all LMD models. They are provided to conserve energy when case is not being used.

**NOTE:** When using optional Security Cover the Night Curtain(s) must be closed.

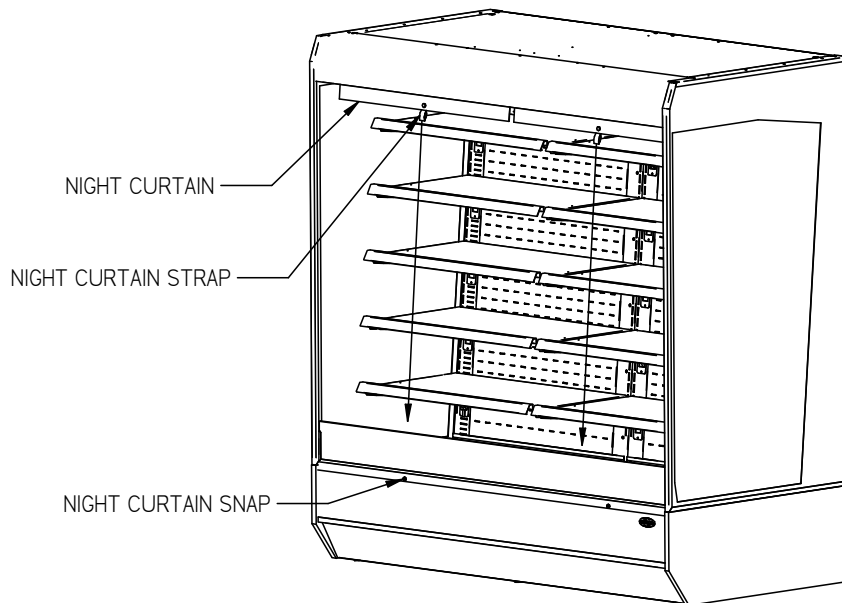

### **OPENING:**

1. Grab night curtain strap located behind the top valance. Pull the night curtain down the front of case opening.
2. Attach the snap located under the night curtain strap on to the snap located on the front trim.

### **CLOSING:**

1. Grab the night curtain strap and detach the snap from the snap located on the front trim.
2. While holding the night curtain strap allow the night curtain to roll up.

**Note:** The LMD72 AND LMD96 models have (2) night curtains.

## **Security Cover Operation (Optional)**

Security Covers are optional on all LMD models. They are provided to cover product and allow case to run while unattended.

**NOTE: When using optional Security Cover the Night Curtain(s) must be closed.**

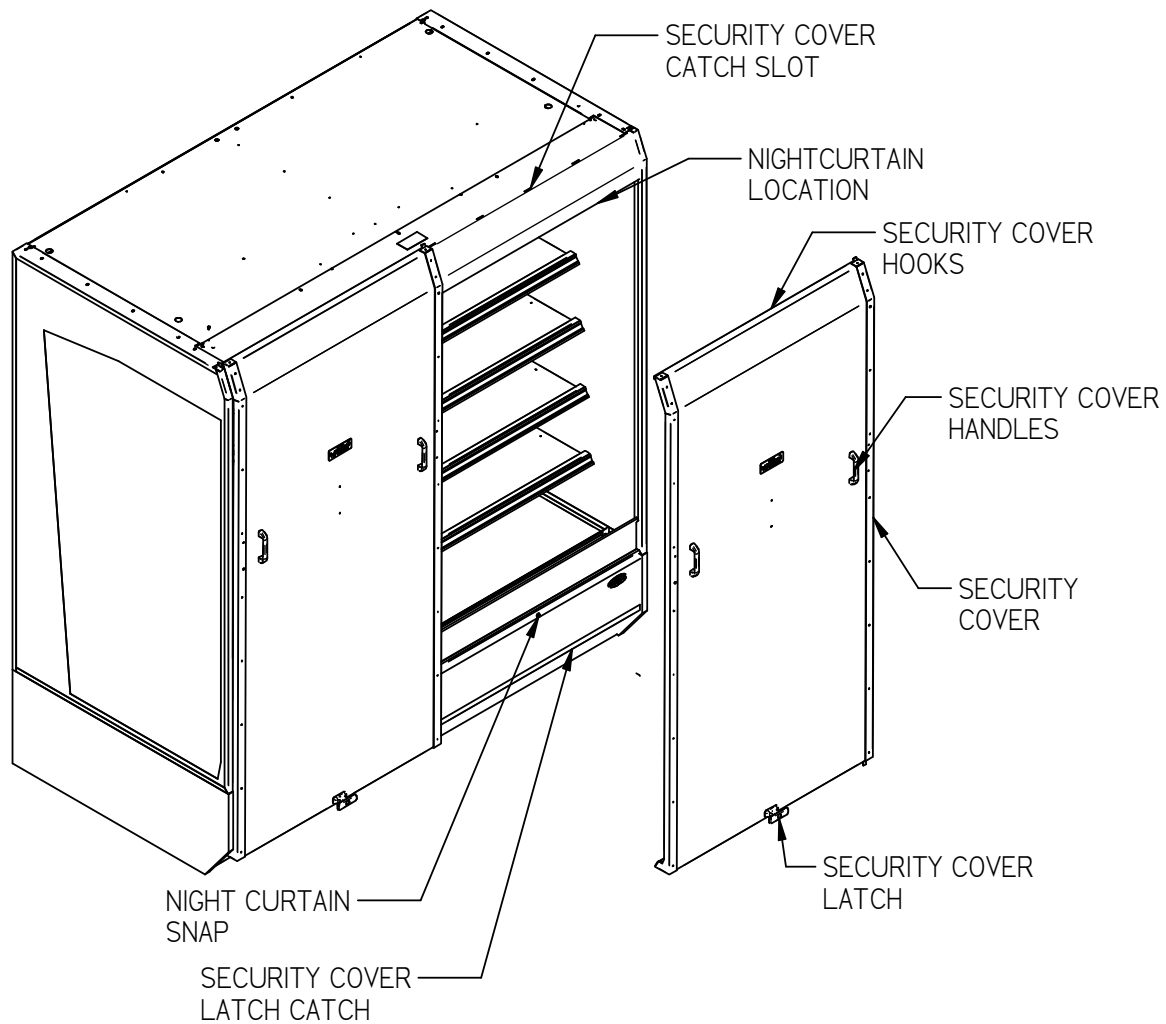

### **REMOVING**

1. Use key provided to unlock Latch.
2. Turn Security Cover Latch vertical to unhook it from Security Cover Latch Catch.
3. Grab Security Cover Handles and lift Security Cover up so the Security Cover Hooks lift out of the Security Cover Catch Slots.

### **INSTALLING:**

1. Close Night Curtain(s) as described in previous section. **IMPORTANT:** Night Curtain must be closed or condensation will form on front of Security Cover.
2. Grab Security Cover Handles and lift it up so the Security Cover Hooks slide down into the Security Cover Catch Slots located on top of case canopy.
3. Push in on bottom of Security Cover and turn Security Cover Latch Horizontal to hook behind Security Cover Latch Catch.
4. Use key provided to lock Latch in horizontal position.

**Note:** The LMD72 AND LMD96 models have (2) security covers.

## **Initial Start-Up**

After all the checks outlined in the installation section of this manual have been made, the case is ready to be put into service. Turn on the Power at the breaker box and flip the Power Switch and Light Switch on unit to the on position.

At start up from a warm unit, it is recommended that the temperature control is set at a warm setting, such as 1 on the dial. After the unit has gone through several cycles, turn the control to a mid-range setting, then to a colder setting if necessary to maintain desired product temperature



**NOTICE:** This refrigerated display case is designed to operate in a maximum environment of 75 DEG. F and 55% relative humidity. Exceeding these limits will cause poor case performance and excessive sweating.

## **Placing Product into Case**

- Do not exceed 100 pounds of weight per shelf. Heavy product should be distributed evenly across the entire shelving area.
- Determine desired shelving location before placing product in case. Product must be removed to readjust shelf location.
- Allow a minimum of 2” between top of product and bottom of shelf.
- Do not overhang the front or rear of shelves with product. Improper clearance in front and rear of shelf will block the refrigerated airflow and will cause product loss.
- Do not block the slots along the front and rear air discharge slots. Covering these slots will block the refrigerated airflow and could cause product loss.
- The display deck is removable for cleaning and can become dislodged in shipment. To ensure proper airflow and performance of the case, make sure that the display deck is pushed completely down.
- Allow refrigerated models to run for at least two hours before placing pre-chilled product into unit.



**NOTICE:** CASE MUST BE STOCKED WITH PRE-CHILLED PRODUCT 38° OR COLDER.



**NOTICE:** This refrigerated display case is designed to operate in a maximum environment of 75 DEG. F and 55% relative humidity. Exceeding these limits will cause poor case performance and sweating of glass panels.

---

---

# MAINTENANCE

---

---

## Top Light Bulb Replacement

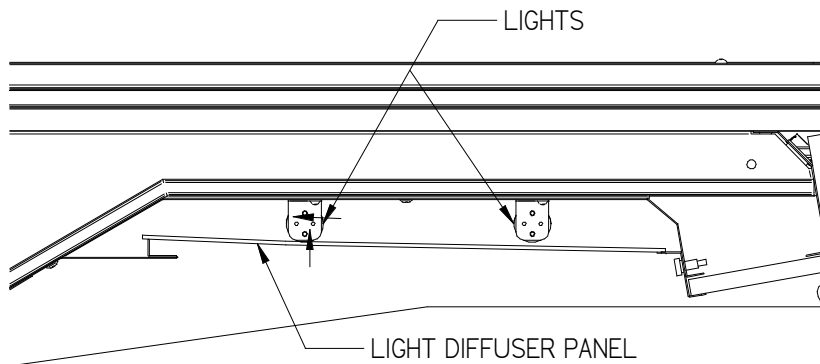

There are (2) top lights on the LMD4878 & LMD7278 and there are (4) on the LMD9678. To access these lights, the top light diffuser must be removed.

1. Remove the top shelf or shelves from the case.
2. Push up on the back of the Light Diffuser Panel and slide it back over the lip on the rear retainer until the front drops down of the front retainer.
3. Once light diffuser is removed the lights can be removed.
  - Florescent T8 bulbs:** T8 bulbs can be removed by pushing the bulb towards the spring-loaded receptacle until it can be removed from the stationary receptacle and replace in reverse order.
  - LED Strip Light:** Led can be removed by unplugging cord from end of led and then unsnapping lights from the light clip. Replace LED light in reverse order
4. Reinstall light diffuser.

## Cleaning Condenser Coil



**NOTICE:** Condenser coil must be cleaned a minimum of twice per month to insure proper refrigeration performance and prevent compressor failure. In some environments, it may be necessary to clean more frequently. **FAILURE TO CLEAN CONDENSER COIL WILL VOID COMPRESSOR WARRANTY.**

The condenser coil is remotely mounted in another location, but it is very important that the Condenser coil is cleaned twice per month to insure proper refrigeration performance and to prevent compressor failure. Failure to clean condenser coil will void condenser warranty.

1. Find the remote mounted Condensing unit
2. Disconnect power to the unit.
3. Carefully vacuum the front surface of condenser coil. Take care not to bend coil fins with vacuum cleaner nozzle.

---

---

# CLEANING INSTRUCTIONS

---

---

## Daily Cleaning

The case should be cleaned thoroughly, as described in the weekly cleaning section, before it is used for the first time.



**NOTICE:** Avoid splashing or soaking any electrical components with water to prevent electrical damage to the case.



**NOTICE:** Shut off lights, disconnect power and remove all products from case. Allow sufficient time for the unit to reach room temperature before proceeding with cleaning.



**NOTICE:** Remove all products from the case before proceeding with cleaning procedure.



**NOTICE:** Acrylic air deflector requires special washing procedures to prevent hazing and yellowing of material. Clean as described in “Acrylic Air Deflector Cleaning” section of this manual.

**Note:** For major spills or foreign material buildup use complete weekly cleaning instructions.

**Note:** Detergents are not recommended and do not use abrasive cleaners or pads to prevent scratching of surfaces.

1. Dip rag in warm soapy water and ring out thoroughly. Wipe complete interior of case and dry with soft dry towel.

2. The remaining exterior surface should be wiped down using any ammoniated cleaners or soapy warm water and dried with soft dry towel.



3. **IMPORTANT:** Cleaning the clear acrylic plastic front air deflector requires special care to prevent hazing and yellowing of material. Clean as described in “Acrylic Air Deflector Cleaning” section of this manual.

**NEVER USE** paper towels (wet or dry) for cleaning or drying and never use a dry towel.

**NEVER USE** glass cleaner of any kind.

Lightly dust (not wipe) surface with a damp Micro Fiber towel or chamois. The surface can then be washed using a small amount of dishwashing detergent such as Dawn or Joy and lukewarm water. Use a Micro Fiber towel or chamois, applying only light pressure. The cloth or chamois must be kept free of grit by frequently rinsing. Rinse surface with clear water and dry by blotting with a damp Micro Fiber towel or chamois.

## Weekly Cleaning



**NOTICE:**

Shut off lights and disconnect power and remove all products from case. Allow sufficient time for the unit to reach room temperature before proceeding with cleaning.



**NOTICE:**

Avoid splashing or soaking any electrical components with water to prevent electrical damage to the case.



**NOTICE:**

Remove all products from case before proceeding with cleaning procedure.



**NOTICE:**

Acrylic front air deflector requires special washing procedures to prevent hazing and yellowing of material.

**Note:** Detergents are not recommended and do not use abrasive cleaners or pads to prevent scratching of surfaces.

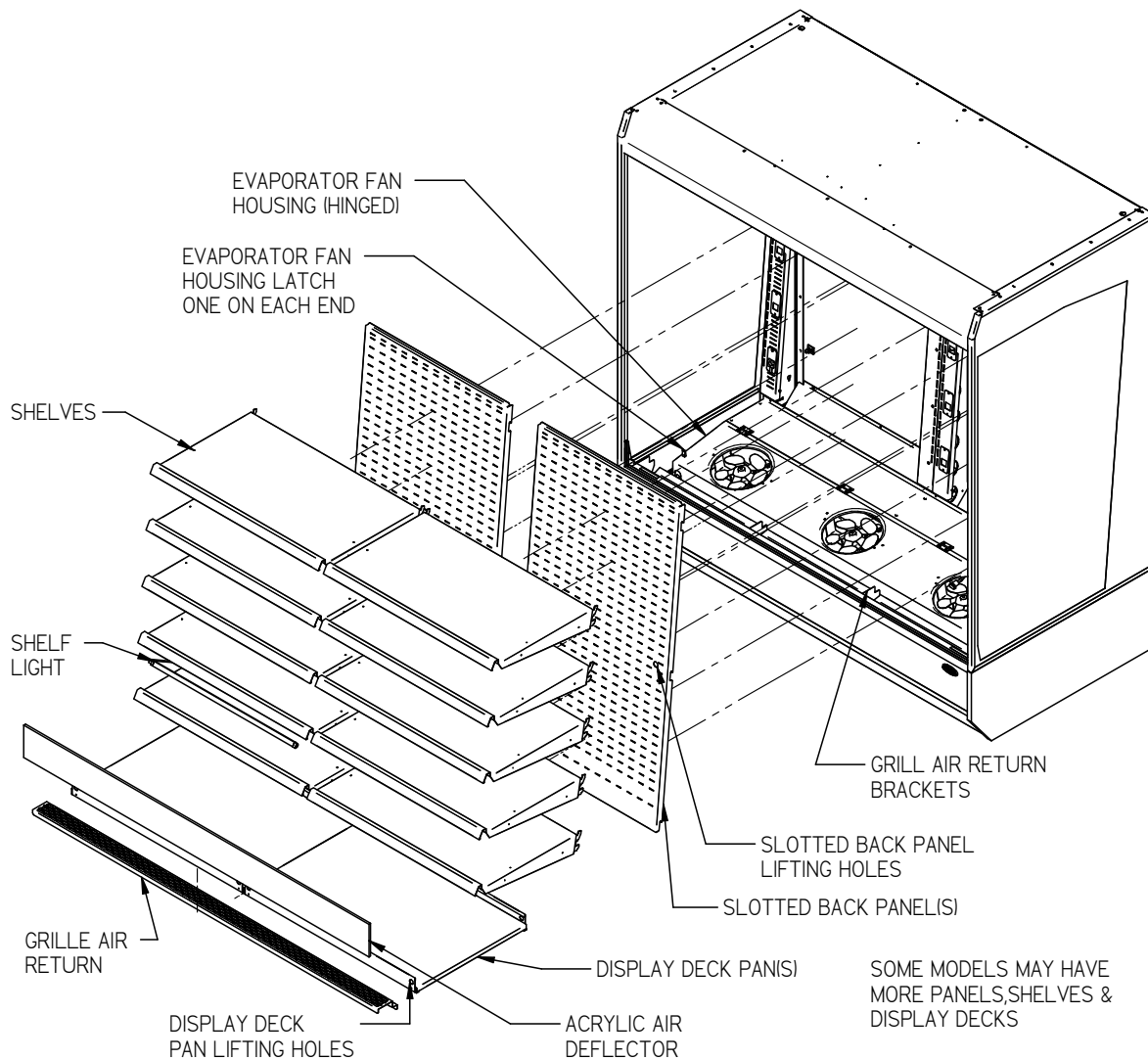

1. Remove the Acrylic Air Deflector by lifting it up and out of Air Deflector Retainer. Clean as described:



**IMPORTANT: Cleaning the clear acrylic plastic front air deflector requires special care to prevent hazing and yellowing of material. Clean as described in “Acrylic Air Deflector Cleaning” section of this manual.**

**NEVER USE** paper towels (wet or dry) for cleaning or drying and never use a dry towel.

**NEVER USE** glass cleaner of any kind.

Lightly dust (not wipe) surface with a damp Micro Fiber towel or chamois. The surface can then be washed using a small amount of dishwashing detergent such as Dawn or Joy and lukewarm water. Use a Micro Fiber towel or chamois, applying only light pressure. The cloth or chamois must be kept free of grit by frequently rinsing. Rinse surface with clear water and dry by blotting with a damp Micro Fiber towel or chamois.

2. Remove interior Shelves and Shelf Lights from unit as described in the “Shelving Installation” section of this manual.
3. Remove the Display Deck Pan(s) from unit by grabbing the lifting holes located on front lip of Display Deck Pan(s) and lifting them up and out of unit.
4. Remove the Grill Air Return by lifting it up and off the Grill Air Return Brackets.
5. Remove the Slotted Back Panel(s) from unit. Lift the Slotted Back Panel up until the bottom of panel clears the evaporator cover and then swing the bottom of the Slotted Back Panel out until the top of panel clears the top light housing flange.
6. Dip rag in warm soapy water and ring out thoroughly. Clean all shelves, Display Deck(s), Grill Air Return and Slotted Back Panel(s) and dry with soft dry towel.
7. Clean the entire interior of the case using warm soapy water. Wipe off all soapy water with a damp cloth and allow to dry. (DO NOT use solvents such as Acetone, Benzene, Carbon Tetrachloride, and Lacquer Thinners)  
Clean under the Evaporator Fan Housing and Drain area by lifting (2) Evaporator Fan Housing latch levers up and swinging the hinged Evaporator Fan Housing up and out of the way.
8. Remove the honeycomb air diffuser(s) from upper air duct track. Loosen thumb screws on Retainer located behind diffuser. Retainer will drop down allowing diffuser to be pulled out of case.

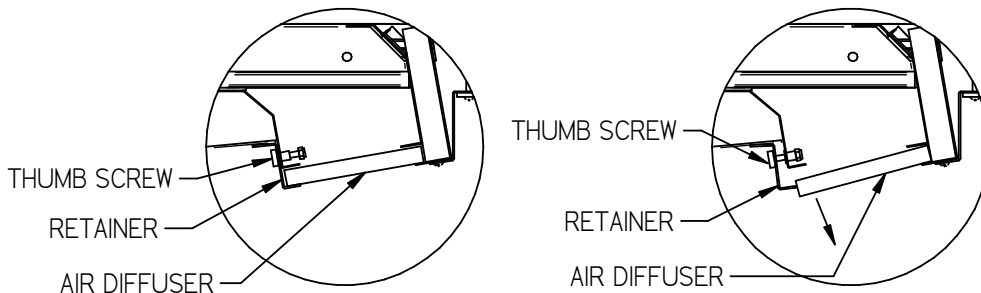

9. Clean honey comb air diffuser with warm soapy water and a brush. Rinse thoroughly and allow to dry.
10. Reassemble all components in reverse order.

**NOTE:** Depending on the amount of usage and spillage of foreign material, some fasteners may have to be removed and parts disassembled to allow proper cleaning of the unit.

---

---

# MISTER OPTION

---

---

This case may be supplied with a mister option kit. The mister rail and mister nozzles are installed in the case at the factory along with the mister inlet hose.

Assemble the controller and pressure tank in desired location as outlined in the instructions included with the mister kit and attach to the mister inlet hose.

Set the control interval cycle times between mist operation and the duration of misters on time to achieve desired mister results. It is recommended to try to have as much time between mister operation and the shortest mist on time as possible to achieve the desired results. If too much water is added to the case it could cause refrigeration coil to build ice and cause poor case performance.

The mist nozzles can be tilted in and out to desired location. It is recommended that the nozzles point to the inside of the case to prevent water mist on floor.

The nozzle spray mist pattern can also be adjusted by turning the end of each nozzle.

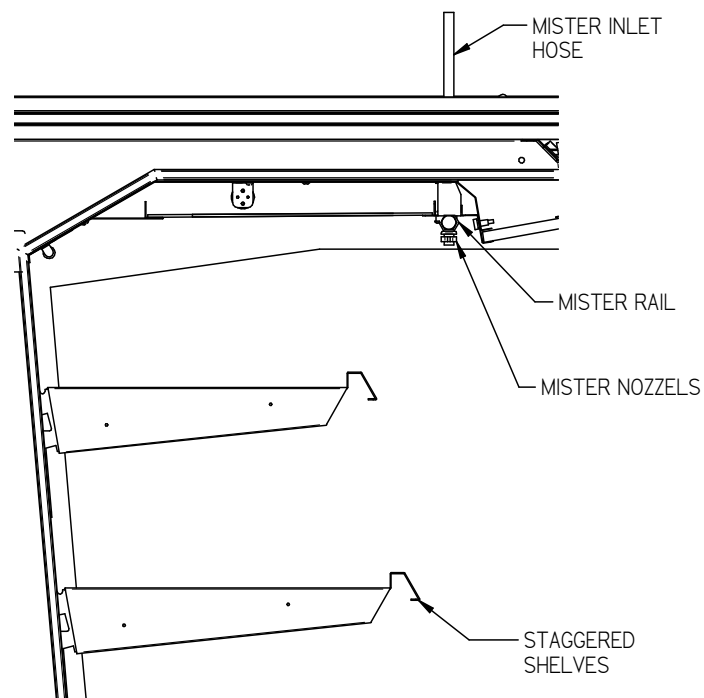



---

---

# SERVICE INFORMATION

---

---

**CAUTION**  
RISK OF ELECTRIC SHOCK  
DISCONNECT POWER BEFORE  
SERVICING UNIT

**Before any service work  
is performed on the  
case, make sure all  
power is disconnected  
to the case.**

**To find a service company in your area, please visit our website at [www.federalindustries.com](http://www.federalindustries.com). There you can also find self-service tools to help you get the answers you need faster!**

**For Warranty Service Requests & ALL Technical Support please contact:**

- **Phone:** (800) 356-4206 and choose the Tech Support/Warranty Option
- **Email:** [Service@federalind.com](mailto:Service@federalind.com)

**For Warranty Compressors please contact the Parts Department:**

- **Phone:** (800) 356-4206 and choose the Warranty Parts Option
- **Email:** [Parts@Federalind.com](mailto:Parts@Federalind.com)



**Federal Industries has partnered with Parts Town for ALL Non-Warranty Part Identification, Pricing, Lead Times, Orders & Freight Quotes. Please contact Parts Town directly if you need parts:**

- **Website:** [PartsTown.com](http://PartsTown.com)
- **Email:** [CustomerService@PartsTown.com](mailto:CustomerService@PartsTown.com)
- **Phone:** 833-809-8188

## Special Service Situations

There are rare occasions when the refrigerant charge must be evacuated from a case in order to perform service work. In those situations, Federal Industries recommends that the refrigerant charge be evacuated into a recovery system to prevent the possibility of hydrofluorocarbons (HFC's) from being released into the atmosphere.

If moisture or liquid is observed around or under a Federal Industries case, an immediate investigation should be made by qualified personnel to determine the source of the moisture or liquid. The investigation made should determine if the case is malfunctioning or if there is a simple housekeeping problem.



**NOTICE:**

**Moisture or liquid around or under a case is a potential slip/fall hazard for persons walking by or working in the general area of the case. Any case malfunction or housekeeping problem that creates a slip/fall hazard around or under a case should be corrected immediately.**

## **Pre-Service Checklist**

You may avoid the cost and inconvenience of an unnecessary service call by first reviewing this checklist of frequently encountered situations that can cause unsatisfactory case performance.



**CAUTION:** Before servicing case, turn off power at the main breaker of fuse box.

### ***Case Does Not Operate***

- Check for disconnected power supply.
- Check for tripped breaker on blown fuse.
- Check that the thermostat display is on and that the green indicator light is lit.

### ***Lights Do Not Operate***

- Check that light switch is on.
- Check for tripped breaker or blown fuse.
- Check that light housing cords are plugged in correctly to sockets in the tower

### ***Case Temperature Too Warm***

- Check that the cold air inlet and outlet slots are not blocked.
- Check for a blocked or dirty condenser coil.
- Check for cold airflow. Lack of adequate cold airflow could indicate a defective evaporator fan or a blocked evaporator coil. Check that paper or foreign materials are not blocking evaporator. If the evaporator coil is blocked due to excessive frost, put into manual defrost. Excessive frost can buildup overtime if the case is set too cold or if there is excessive humidity in the store.
- Check all the fans in the evaporator compartment and tower are running.

### ***Case Sweating Note:*** Some interior sweating is normal on this case.

- Check room ambient – Case is designed to operate in an environment not to exceed 75°F and 55% relative humidity.
- Check all the fans in the evaporator compartment are running.

### ***Overflow of Condensate Pan***

- Check that drain in bottom of tub floor is not plugged.
- Check that drain trap to the condensate pan is not plugged

### ***Overflow of Optional Condensate Pump:***

- Check that drain in bottom of tub floor is not plugged.
- Check that drain trap to the condensate pan is not plugged
- Check that drain lines from pump is not plugged or pinched.
- Check to see that pump float is operating correctly.
- Verify that pump is plugged in and has power.
- Replace pump if still not pumping condensate.

---

## SALE & DISPOSAL

---

If you the owner sells or gives away this Federal Industries case it is the owner's responsibility to make sure that all safety labels and the Installation-Service Manual are included with it. If you need replacement labels or manuals, Federal Industries will provide them free of charge. Contact the customer service department at Federal Industries at (800) 356-4206.

The customer service department at Federal Industries should be contacted at the time of sale or disposal of your case so records may be kept of its new location.

If you sell or give away your Federal Industries case, you should evacuate the refrigerant charge before shipment. Federal Industries recommends that the charge be evacuated into a recovery system to prevent the possibility of HCFC's from being released into the atmosphere.

# REFRIGERATION OPERATION

Refrigeration R449 Charge	CHARGED IN FIELD
Remote Low Press. Switch Cut In	40 psi
Remote Low Press. Switch Cut Out	15 psi
Adjustable Head Master	200 psi
Remote High Press. Switch Cut Out	400 psi

The remote models are designed to use 449A refrigerant and shipped from the factory with the evaporator coil, expansion valve, sight glass and refrigerant solenoid valve. Drier filter must be installed in field for proper operation. Electronic control opens and closes a refrigeration solenoid valve located on the suction line and shuts off the refrigeration flow to the unit and initiates a pump down cycle. This will allow the remote low-pressure switch to open and shut off remote compressor.

The condensing unit and pressure controls are optionally supplied from the factory for remote location installation. The condensing unit must be mounted and wired by the installer. The high low-pressure switch must be wired in series with the compressor power supply as shown in diagram below.

1. Mount condensing unit indoors as close to the remote display case as practical. The refrigeration line should be as short as possible and must not exceed 30 feet.
2. All refrigeration and/or electrical materials between the condensing unit and display case are to be supplied by installing contractor.
3. Route properly sized and designed refrigeration lines from the condensing unit to the cabinet. Horizontal suction lines should be pitched downward towards the condensing unit at least  $\frac{1}{2}$ " per 10' run to aid the oil drainage. A "P" trap must be installed in the suction line at the foot of every riser to insure oil return. Dry nitrogen must be used to flow through tubing while brazing refrigeration lines.
4. Suction line must be insulated the entire length with Armaflex (or equivalent). Do not run liquid line inside insulation with suction line.
5. The remote high/low-pressure control must be installed and set pressures by the installer.
6. Leak check condensing unit, cabinet, and all connecting tubing. Cabinet and condensing unit tubing should be checked to insure no leaks occurred during shipping or from rough handling. Make certain all refrigeration valves are opened and evacuate system to 500 microns. Charge the system with refrigerant type specified on the data plates.

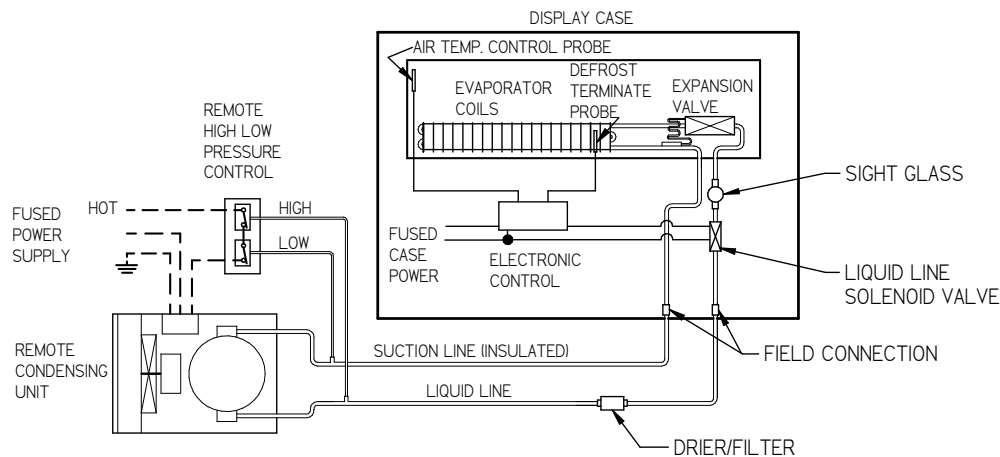

## Electronic Expansion Valve (EEV) After 1/20

A traditional TXV uses springs and a temperature bulb to open and close a valve port that controls the flow of refrigerant entering the evaporator coil. An electronic expansion valve (EEV) controls the refrigerant flow much more precisely, increasing the performance and efficiency of the refrigeration system. The EEV controls the flow of Refrigerant by opening and closing the valve port based on the response to signals sent to the EEV by an electronic controller. The electronic Control bases these signals by processing information provided from a temperature sensor and pressure transducer located on the discharge side of the evaporator coil. These sensors monitor the evaporator superheat and protects the compressor from any liquid flood back under low superheat conditions.

### **EEV Controller Settings**

The electronic expansion valve controller also allows the use of different types of refrigerants without the need to change the expansion valve.

The controller is set from the factory to run on 449A refrigerant and will not need any changes to the control unless another refrigerant is used.

**Note: Check your State and Local regulations for approved refrigerants for your install location. Federal Industries is not liable for any alternate refrigerants used.**

The control is located in the front left corner of evaporator tub under the Display Deck Pan.

**Note: Never change any of the other setting other than the refrigerant type. It may also be necessary to change the superheat setting only when using a different refrigerant.**



Indicator lights	
	Red light - critical alarm (system is NOT running)
	Yellow light - non-critical alarm (system running)
	Green light - compressor on
	Green blinking - compressor waiting on timer to start/stop

### Changing Refrigerant

- Access the set point mode by pressing and holding the **ENTER** button until Ctl displays on the screen.
- Use the up or down arrows to advance through the available set points until rFG displays on the screen and press the **ENTER** button.
- Use the up or down arrows until the desired refrigeration displays on the screen and press and hold the **ENTER** button until rFG once again displays on the screen.
- Press the **BACK** to return to escape the settings menu.

### Changing Superheat

- Access the set point mode by pressing and holding the **ENTER** button until Ctl displays on the screen.
- Use the up or down arrows to advance through the available set points until SSP displays on the screen and press the **ENTER** button.
- Use the up or down arrows to set the desired superheat displays on the screen and press and hold the **ENTER** button until SSP once again displays on the screen.
- Press the **BACK** to return to escape the settings menu.

# PARTS LIST

ELECTRICAL COMPONENTS						
	LMD4878R		LMD7278R		LMD9678R	
	QTY	PART#	QTY	PART#	QTY	PART#
CAREL TEMP. CONT. 115V	1	32-19864-12	1	32-19864-12	1	32-19864-12
TEMPERATURE PROBE	2	32-19866	2	32-19866	2	32-19866
SWITCH,ROCKER 22A	1	41-11066	1	41-11066	1	41-11066
BALLAST, 120V (BEFORE 10/18)	1	39-12902	1	39-12902	1	39-12904
POWER SUPPLY 12V (BEFORE 10/18)	2	39-19984	2	39-19984	4	39-19984
SOCKET,SPRING LOADED (BEFORE 10/18)	2	42-10833	2	42-10833	4	42-10833
SOCKET,STATIONARY (BEFORE 10/18)	2	42-10834	2	42-10834	4	42-10834
BULB,FLORECENT T8 (BEFORE 10/18)	2	42-11069	2	42-11071	4	42-11069
LED, 12V 35k (BEFORE 10/18)	6	42-20043-8	12	42-20043-5	12	42-20043-8
CORD,SHELF LIGHT LED WH (BEFORE10/18)	5	43-20046-2	10	43-20046-2	10	43-20046-2
RECEPTACLE,WHITE	5	43-19080-A	10	43-19080-A	10	43-19080-A
PLATE,RECEPT SHELF LIGHT WH	5	M-10167-2B	10	M-10167-2B	10	M-10167-2B
POWER SUPPLY 24V (AFTER 10/18)	1	39-20555	1	39-20555	2	39-20555
LED CEILING, 24V 35k (AFTER 10/18)	2	42-20871-42C35	2	42-20871-72C35	4	42-20871-42C35
CORD CEILING LED WH(AFTER10/18)	2	43-20867-8W	2	43-20867-8W	4	43-20867-8W
LED, 24V 35k (AFTER 10/18)	6	42-20871-42C35	12	42-20871-30C35	12	42-20871-42C35
CORD,SHELF LED WH (AFTER10/18)	5	43-20862-6W	10	43-20862-6W	10	43-20862-6W
CORD,TOP LED WH (AFTER10/18)	1	43-20868-3W	2	43-20868-3W	2	43-20868-3W
HARNESS,5 LIGHT	1	43-20147	2	43-20147	2	43-20147
REFRIGERATION COMPONENTS						
MOTOR,FAN 115V. 60Hz,	2	41-17981	3	41-17981	4	41-17981
BLADE,8" 5 BLADE, 15D SUCT	2	72-32507	3	72-14569	4	72-32507
HARNESSWIRE,DOUBLE FAN	1	43-19749	2	43-19749	3	43-19749
TXV, 3/8X1/2ODF 30"CAP (BEFORE 1/20)	1	32-19408	1	32-19750	1	32-20212
TXV, 3/8X1/2ODF 30"CAP (AFTER 1/20)	1	32-20874	1	32-21063	1	32-21063
EEV, RSV-130 3/8X1/2ODF (AFTER 1/20)	1	32-21226	1	32-21226	1	32-21226
EEV CONTROL (AFTER 1/20)	1	32-21223	1	32-21223	1	32-21223
TEMP. SENSOR EEV (AFTER 1/20)	1	32-21224	1	32-21224	1	32-21224
PRESSURE TRANSDUCER (AFTER 1/20)	1	32-21225	1	32-21225	1	32-21225
SIGHT GLASS 3/8 ODF	1	32-54011	1	32-54011	1	32-54011
COIL,EVAP MULTI DECK	1	33-20026-1	1	33-20026-2	1	33-20026-3
VALVE, ACCESS 1/4OD, STR.	2	72-17182	2	72-17182	2	72-17182
VALVE, ACCESS 5/8 COPPER	1	82-14323	1	82-14323	1	82-14323
SOLENOID VALVE	1	32-14325	1	32-14325	1	32-14325
COIL,SOLENOID120-240V	1	41-14324	1	41-14324	1	41-14324
SWELL LATCH	2	66-13640	2	66-13640	2	66-13640
HINGE,PLASTIC	3	66-14094	4	66-14094	5	66-14094
MISC COMPONENTS						
PANEL,END GLASS	2	50-20029	2	50-20029	2	50-20029
PANEL,END GLASS REFLECTIVE LEFT	1	50-20029-1L	1	50-20029-1L	1	50-20029-1L
PANEL,END GLASS REFLECTIVE RIGHT	1	50-20029-1R	1	50-20029-1R	1	50-20029-1R
PANEL,LAMINATE FRONT (COLOR REQD)	1	W11732-1	1	W11732-2	1	W11732-3
PANEL,END LAM (COLOR REQD)	1	68-20042-L	1	68-20042-L	1	68-20042-L
PANEL,END LAM (COLOR REQD)	1	68-20042-R	1	68-20042-R	1	68-20042-R
LEG,1/2-13 X 2.5	4	65-11486	6	65-11486	6	65-11486
CASTER,2-1/2"	4	65-17352	6	65-17352	6	65-17352
ECONO COVER,56" DBL ACTION WHITE	1	65-19464	3	65-19462	2	65-19464
AIR DIFFUSER	2	W11724-1	2	W11724-2	2	W11724-3
THERMOPLASTIC DRAIN	1	84-70225	1	84-70225	2	84-70225
DRAIN ASSY,TUBE	1	SA5522	1	SA5522	1	SA5523
TUBING,3/4 ID CLEAR PVC	25'	15-19609	25'	15-19609	25'	15-19609
SHELF,WELD WHITE	5	SA5458-1	10	SA5458-2	10	SA5458-1
THERMOMETER	1	32-13662	1	32-13662	1	32-13662
DEFLECTOR,AIR FRONT	1	15-20030-1	1	15-20030-2	1	15-20030-2
NIGHT CURTAIN	1	65-19464	2	65-19462	2	65-19464
SECURITY COVER (OPTION) NAT ALUM	1	SA5658-1B	2	SA5658-2B	2	SA5658-1B
SECURITY COVER (OPTION) BLACK TEXT	1	SA5658-1	2	SA5658-2	2	SA5658-1
DECAL,CATION ELECTRICAL SHOCK	2	91-12340	2	91-12340	2	91-12340
LOGO,FEDERAL	1	91-72523	1	91-72523	1	91-72523

# Case Wiring Diagrams

## LMD48 & 72 (BEFORE (10/18))

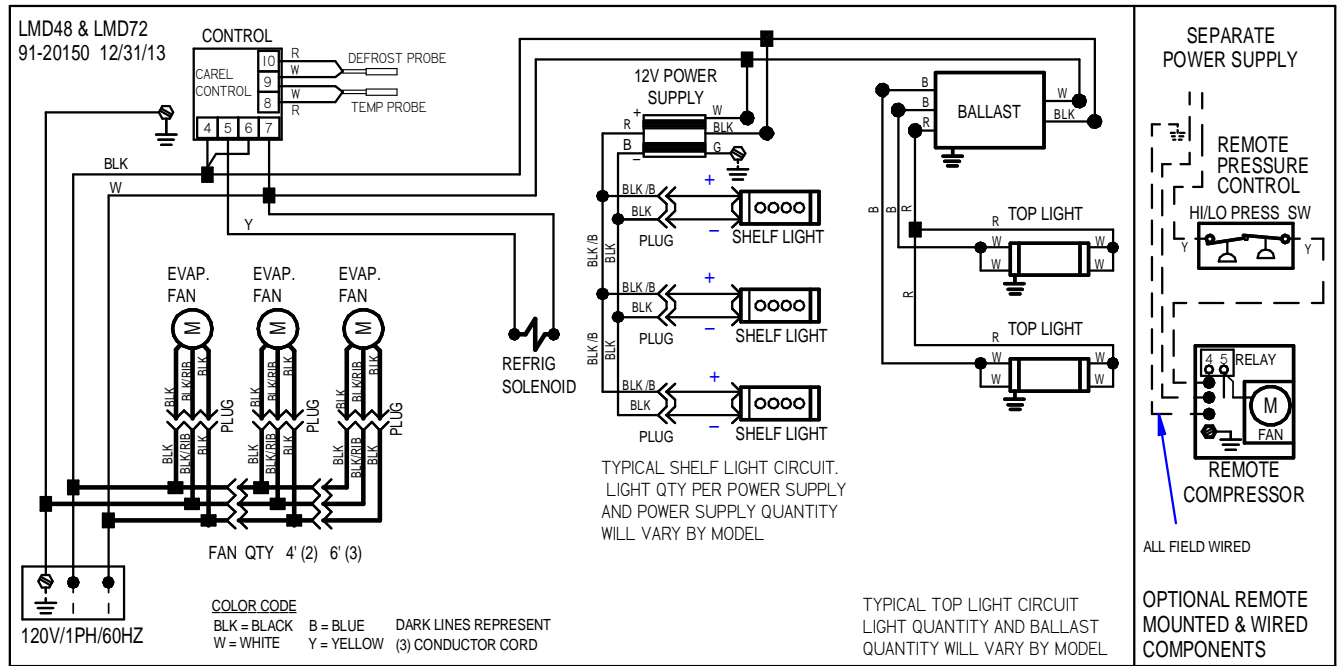

## LMD96 (BEFORE (10/18))

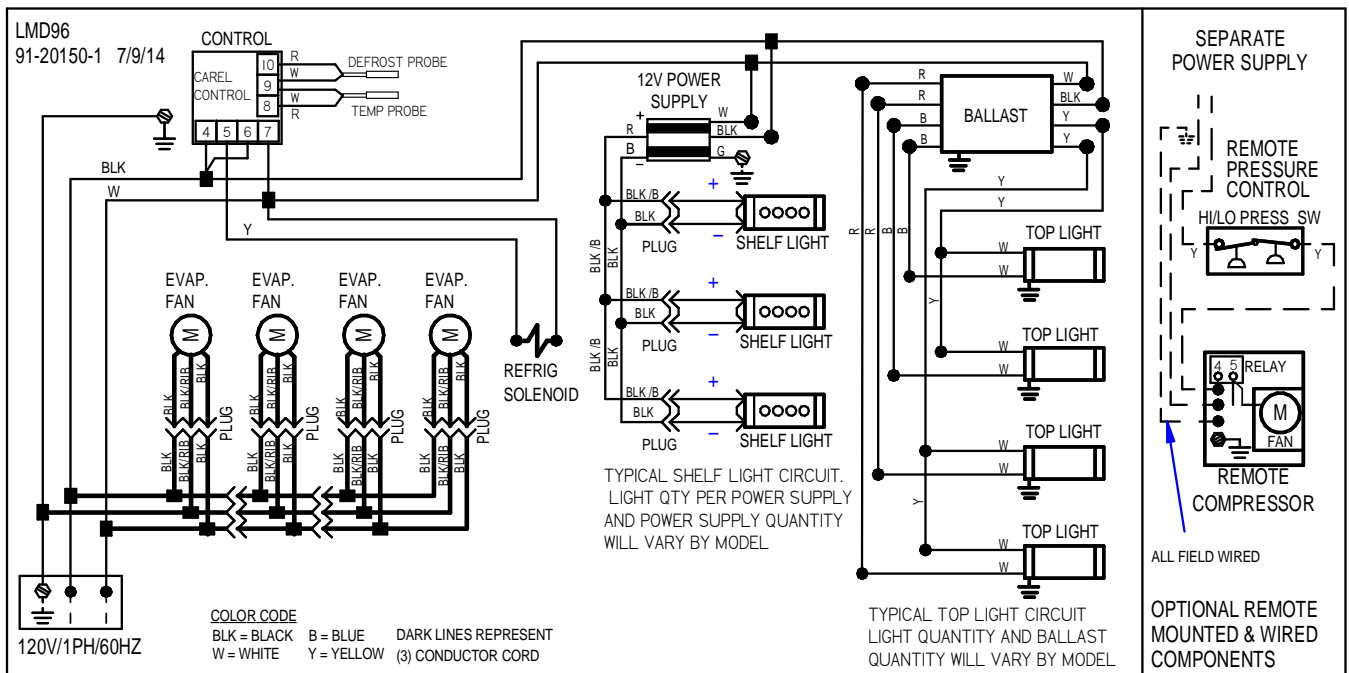





# LMD48 & 96 EEV (AFTER 1/20)

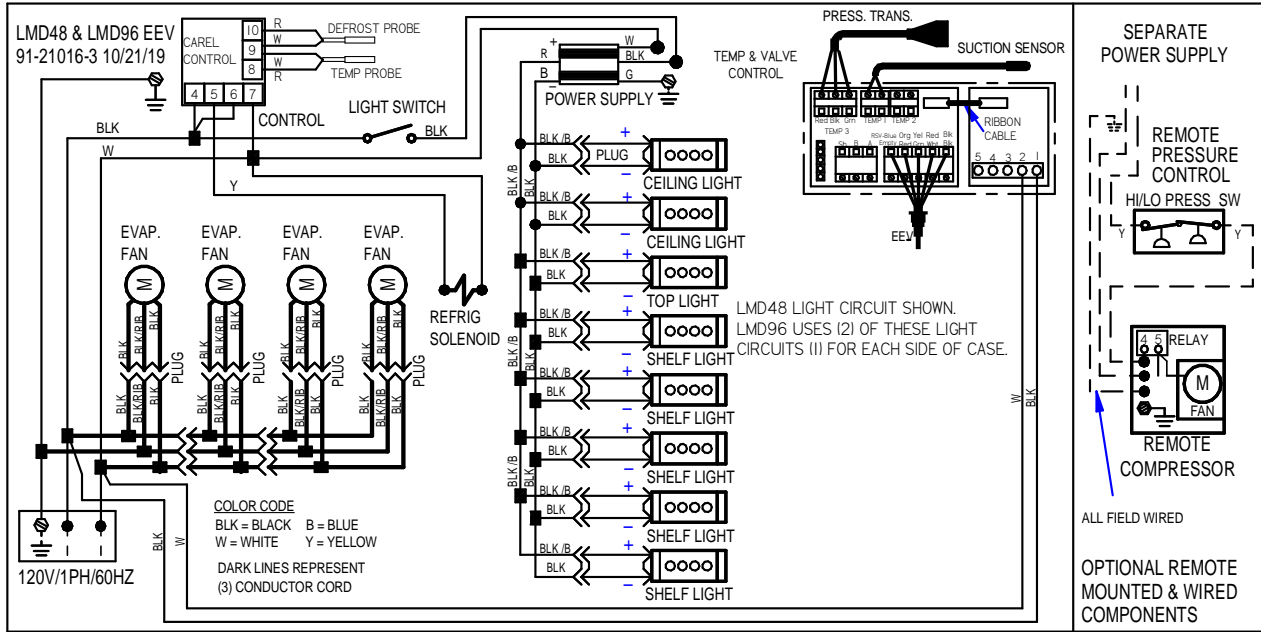

# LMD48 & 96 EEV (AFTER 7/1/24)

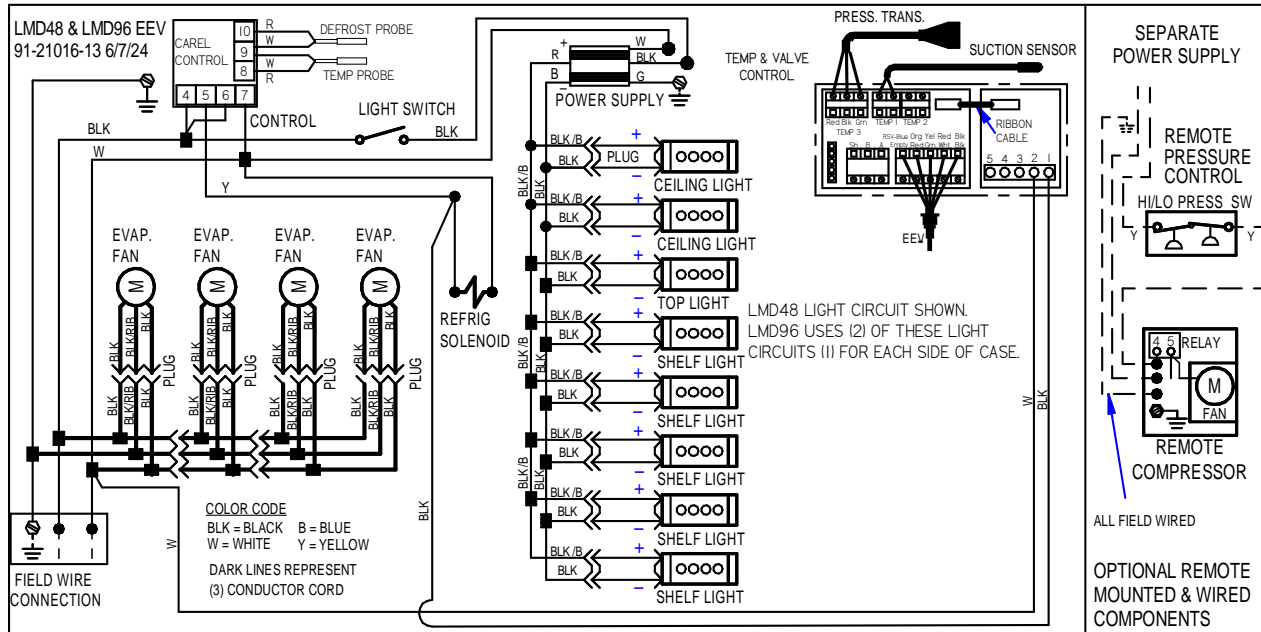

# LMD72 EEV (AFTER 1/20)

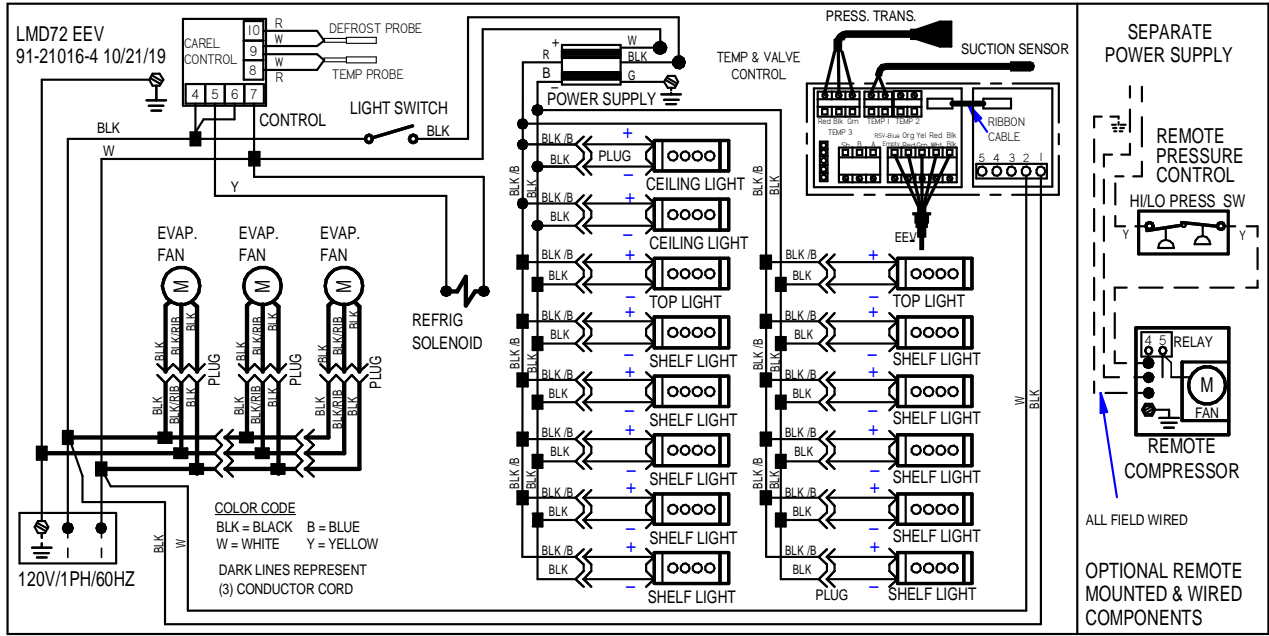

# LMD72 EEV (AFTER 7/1/24)

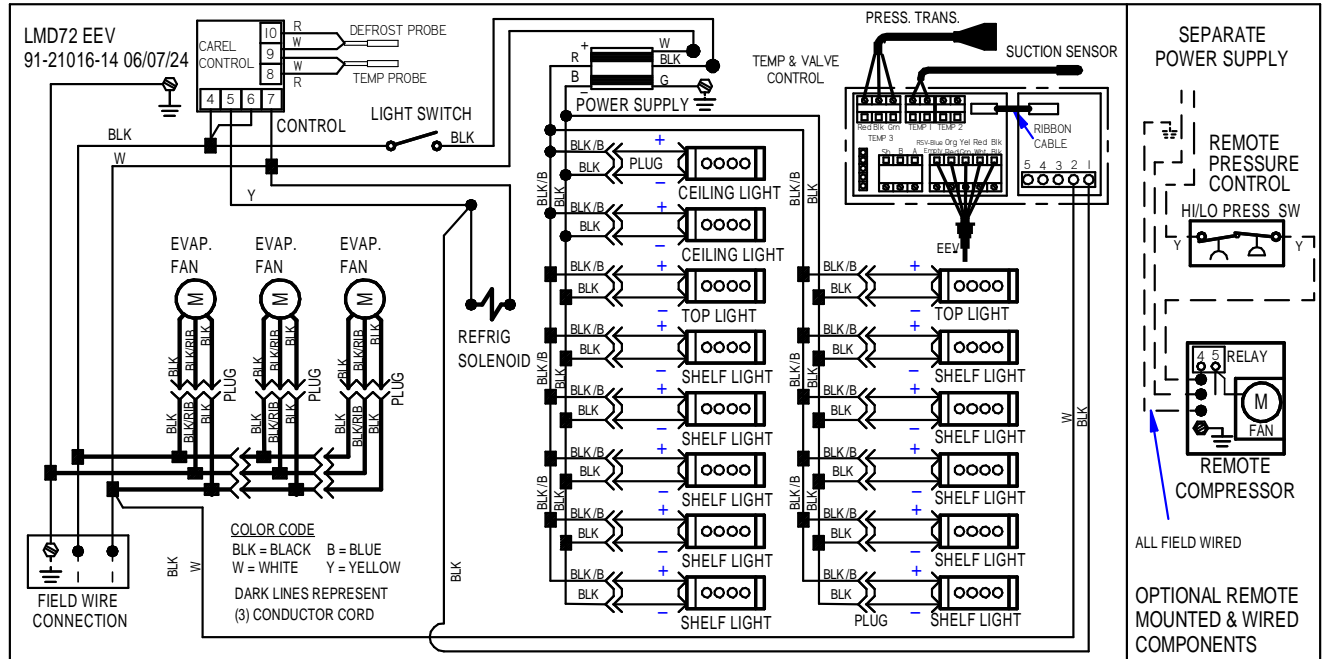

## Condensing unit Installation Instructions

### LMD MODELS with remote top mounted Condensing unit

Condenser unit must have a minimum of 12" of top clearance to provide condenser air to discharge. Ceiling tiles can be removed if needed.

#### Mounting the Condensing Unit Assembly to Top of LMD unit.

This is when condensing unit assembly is mounted directly on top of LMD unit so they become one unit attached together. Rigid or optional flexible refrigeration lines can be used for this application.

Once LMD unit is located in its final position and leveled the condensing unit assembly can then be installed on to the top of the LMD unit.

-Remove the condensing unit assembly from skid by removing the (4) screws holding it to skid.

-Raise the condensing unit assembly up to the height of the merchandiser top. It is recommended using a lift to get the condensing unit to the top, the condensing unit assembly, without the shipping skid weighs approx. 180 pounds. To prevent damage to front or side glass, install the condensing unit assembly from the back of the merchandiser.

-Using the lift handles provided, slide the condensing unit assembly off the skid and onto the top of the merchandiser. Be careful of the refrigeration lines that are protruding above the merchandiser top.

-Locate the condensing unit flush with the back of the merchandiser so that the refrigeration fittings are aligned. Fasten the condensing unit assembly to the top of merchandiser using provided (4) #1/4 self-drilling screws as shown in diagram below (do not over tighten).

-Attach refrigeration lines as described in Refrigeration Line Connections section.

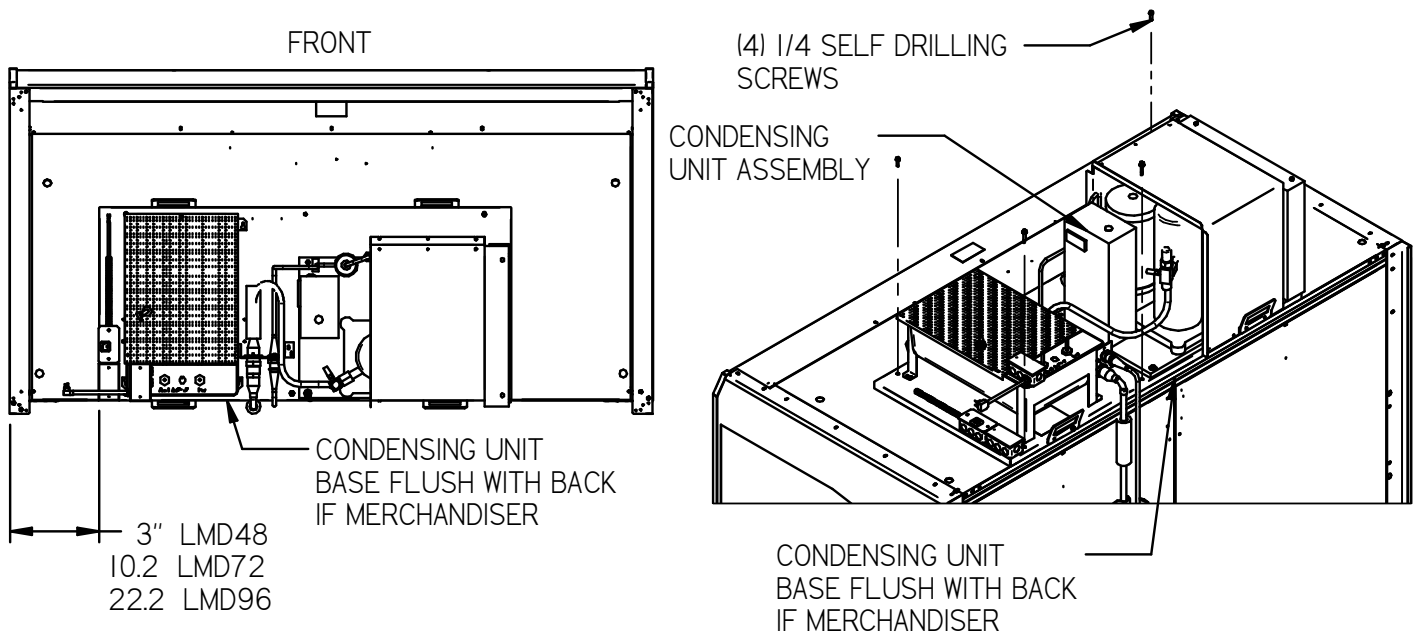

## **Mounting the Condensing Unit Assembly to Frame Structure above LMD unit.**

This is when the condensing unit assembly is mounted directly above LMD unit onto an existing frame work or structure and it is not attached to the LMD case. This allows the LMD unit to move while the condensing unit remains stationary.

A frame work or support structure must be designed and installed by the field contractor as needed per application. This application requires flexible refrigeration lines.

- Remove the condensing unit assembly from skid by removing the (4) screws holding it to skid.
- Raise the condensing unit assembly up to the height of the frame or support structure in desired location above the top of the merchandiser top. It is recommended using a lift to get the condensing unit on to structure, the condensing unit assembly, without the shipping skid weighs approx. 180 pounds.
- Using the lift handles provided, to slide the condensing unit assembly off of the skid and onto the top of support structure and locate as needed. Fasten the condensing unit assembly to the frame or support structure using provided (4) #1/4 self-drilling screws as shown in diagram below (do not over tighten).
- Once the condensing is secured in desired location the LMD unit can be located and leveled in its final position under the condensing unit.
- Attach refrigeration lines as described in **Refrigeration Line Connections** section.

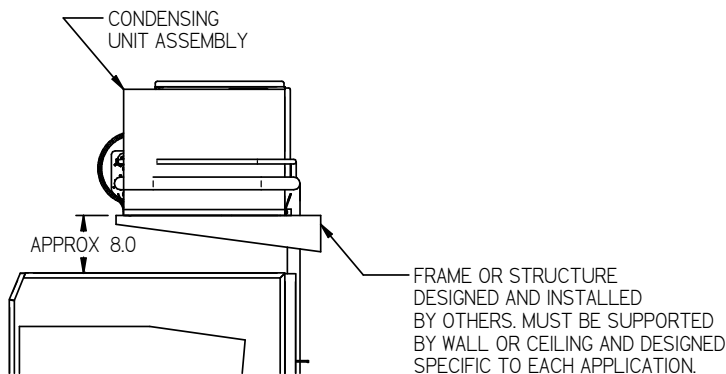

## **Drop Ceiling or False Ceiling Cut Out:**

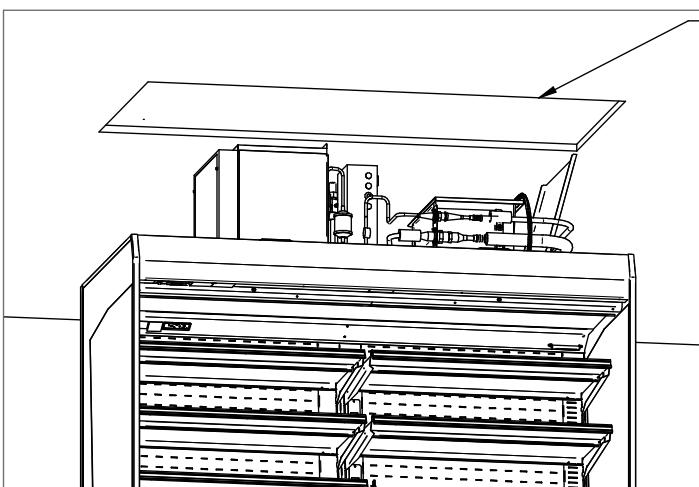

TOP CONDENSING UNIT MUST BE ALLOWED ENOUGH SPACE TO ALLOW HOT CONDENSER EXHAUST AIR TO ESCAPE AND ALLOW COOLER AIR TO ENTER THE INTAKE SIDE OF CONDENSER.

DROP CEILING OR FALSE CEILING MUST HAVE A RECTANGULAR HOLE CUT DIRECTLY ABOVE CONDENSER ASSEMBLY.

HOLE MUST BE A MINIMUM OF 32" DEEP AND A MINIMUM OF 6" LONGER THEN THE ENTIRE CONDENSER ASSEMBLY. THE LARGEST HOLE POSSIBLE IS ALWAYS THE BEST RULE.

## **Shroud Assembly Installation (Optional)**

LMD E3670

Once the condensing unit is installed to the merchandiser unit the outer shroud needs to be installed to hide the condensing unit assembly.

-Remove the shroud assembly from the skid by removing the screws along each end.

-Set the shroud on top of merchandiser. The sides must hang over top of unit until they are flush with the spacer brackets that are attached to the back of merchandiser. The shroud needs to be centered from side to side and even front to back of merchandiser.

-Attach each end of shroud assembly to top of merchandiser using provided (8) #8 self-drilling screws. (There are no screws along front panel to allow removal of top valance on merchandiser)

-Attach the support brackets to the top back side of each shroud side panel using provided (2) #8 self-drilling screws per side.

-Use a square to hold the shroud side panels square and attach the support brackets to the back side of the merchandiser using provided (3) #8 self-drilling screws per side.

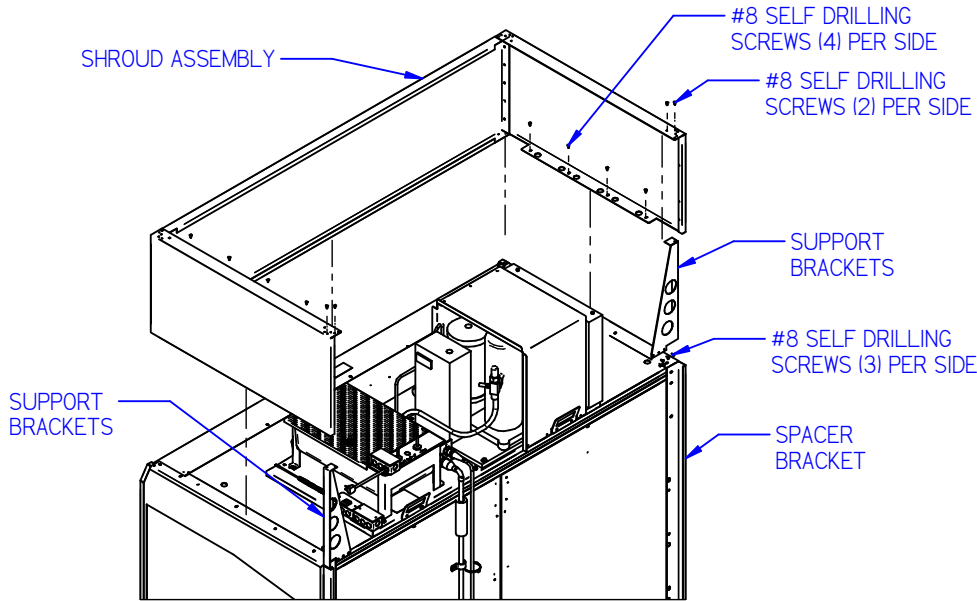

## Electrical Connection



**DANGER: Improper or faulty hookup of electrical components in the display case can result in severe injury or death**

-Only a licensed electrician must perform all case electrical connections.

-All electrical wiring hookups must be done in accordance with all applicable local, regional, or national electrical standards.

-A separate circuit for each display case is required to prevent other appliances on the same circuit from overloading the circuit and causing malfunction.

-The electrical service must be grounded upon installation.

-See the electrical data plate for display case and Condensing unit assembly for proper circuit size and wire ampacity.

There are two power sources required for this unit. The LMD merchandiser requires a 120/1/60 power supply and the condensing unit assembly requires 240/1/60 power supply. The Merchandiser unit and the condensing unit assembly do not share any wiring. The refrigeration system is operated by the use of a solenoid in the merchandiser and a pressure control located on condensing unit.

**LMD Merchandising Electrical Connection:** The electrical connection box is on the bottom left side of case behind the bottom Front Kick Panel. The box is accessible by removing

the Front Kick Panel. (See “Panel Removal Section” of the owner’s manual for panel removal instructions). Remove electrical box cover to access electrical connection. An optional power cord may be provided.

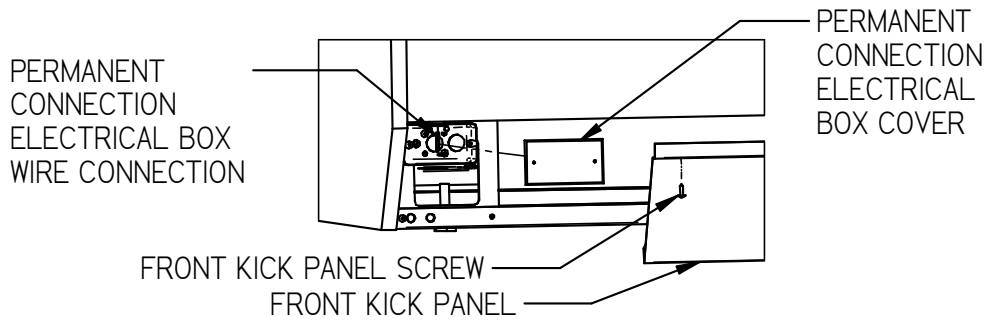

**LMD Condenser Unit Electrical Connection:** The electrical connection box is located on the rear corner of the condensing unit assembly. Remove electrical box cover to access electrical connection. An optional power cord may be provided.

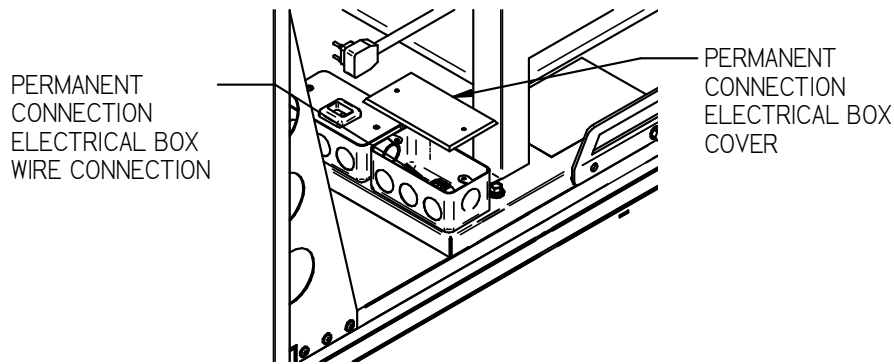

## **Refrigeration Line Connections.**

The remote merchandiser and the condensing unit are both pre-charged with refrigerant. Reusable quick connect couplings are provided for field installation. If top condensing unit assembly must be removed the quick connect couplings can be disconnected and reused. After the condensing unit assembly is securely attached to the merchandiser, remove the plastic caps from the fittings and make the refrigerant line connections as described below. Once connection is made, it is recommended to leak test the quick connect fittings using a soap solution to insure the joints are leak free. Both refrigeration service valves on the condensing unit are 'back seated' when shipped and do not require adjustments in the field.

### **Rigid Refrigeration Line Connection**

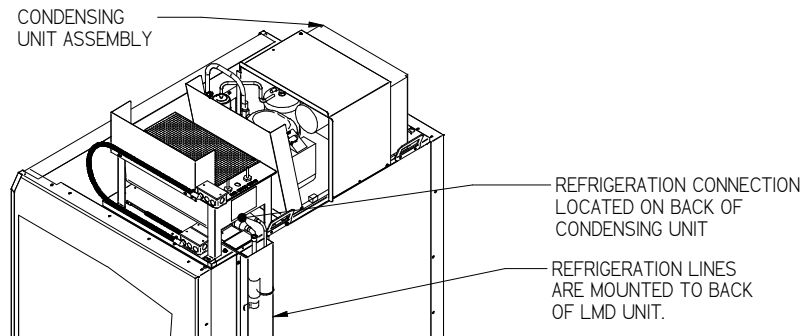

The Rigid refrigeration lines are factory mounted to back of LMD case. Once located in proper position the couplings between top condensing assembly and LMD unit can be made as described in in Line-Set Field Installation Instruction section below.

### **Flexible Refrigeration Line Connection**

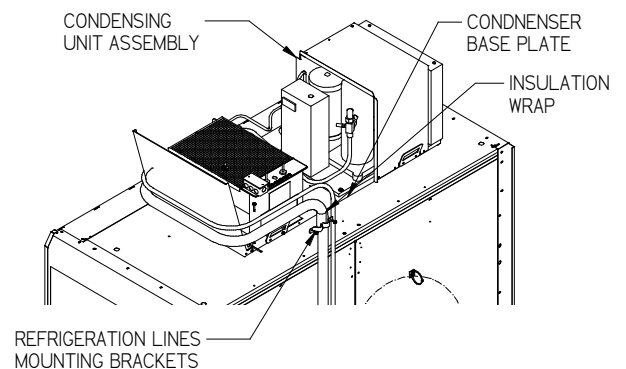
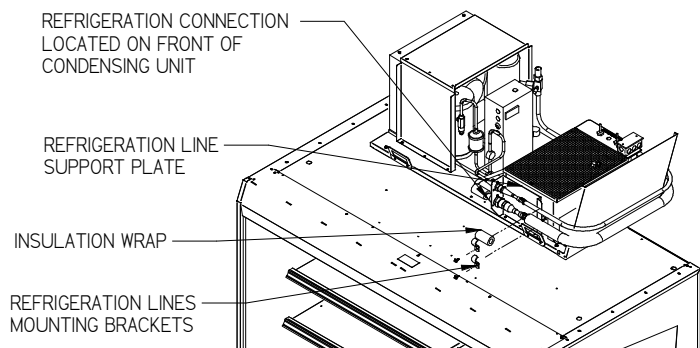

- Cut the wire ties holding the wrapped flexible refrigeration lines to the back of LMD display case.
- Rout the lines as needed over the top of the LMD case to the front of the condensing unit where the refrigeration connections are located. This routing will vary depending on application. Use caution to route lines so that they do not pinch or over bend.
- Connect couplings between top condensing assembly and LMD unit can be made as described in Line-Set Field Installation Instruction section below.
- IMPORTANT:** The refrigeration lines must be attached to the support plate using the mounting brackets. Insulation wrap must be in the location of mounting bracket to prevent damaging lines.
- There also mounting brackets located on back of condensing unit. These may or may not be used depending on the particular routing of the lines. It is just important that the lines are secured in such a manner to prevent damage to lines if the LMD unit is moved around. Any extra Refrigeration line should be left loose behind the LMD unit to allow LMD to be moved around without pulling on line set.

# Line-Set Field Installation Instructions

## Step 1

Apply refrigerant oil to the entire surface of diaphragm, o-ring, and threaded area of male coupling assembly. The amount of lubricant used must cover all designated surfaces sufficiently. Ideal application is a small applicator brush saturated with lubricant and applied liberally. An alternate lubricant for this application is a refrigerant compatible silicone grease product like Dow Corning DC200/60,000 cst.

## Step 2

Ensure that the coupling halves are held in proper alignment with each other prior to starting the threads of the female coupling nut onto the male half. The coupling end faces should be parallel with each other and visually in line with each other, this allows the female

coupling nut to be easily threaded on by hand for the initial 2-3 rotation of the union nut. These initial rotations will bring the diaphragm in contact and a sharp increase in torque will be felt when they come into contact.

**If the nut will not start by hand, adjust the position of the line set to ensure proper coupling alignment and eliminate/minimize all side-load force on the coupling during assembly.**

## Step 3

Using appropriate size wrenches, reference table below for the female coupling body and female union nut, tighten the female union nut while preventing rotation of the female body with respect to the male half. The nut should be tightened until a definite increase in resistance, metal to metal contact occurs, is felt (at

this point, the nut will have covered most of the threads on the male body). It is important to ensure the male and female coupling bodies **DO NOT ROTATE** during any portion of the wrench installation.

## Step 4

Using a permanent marker or scribe, mark a line lengthwise from the female coupling union nut to either the bulkhead or female coupling body. Then tighten an additional one (1) wrench flat (60°); refer to the marking on the union nut to confirm the rotation has occurred. This final rotation is necessary to ensure the formation of the leak-proof seal, between the male and female couplings.

## Step 5

Repeat step 1 through 4 for all connections.

Size Designation	Torque Values Union Nut Min-Max		Male Coupling Hex Size		Female Coupling Union Nut Hex Size		Female Coupling Body Hex Size	
	Ft. Lbs	N.m	Inches	mm	Inches	mm	Inches	mm
-Copper-06	10-12	13.5 - 16.2	3/4	19.05	11/16	17.46	5/8	15.87
-Copper-10	35-45	47.5 - 61.0	1-1/16	26.98	1-5/16	33.33	1	25.40
-Copper-11	35-45	47.5 - 61.0	1-1/8	28.57	1-5/6	46.55	1	25.40
-Copper-12	50-65	67.8 - 88.1	1-7/16	36.51	1-3/8	34.9	1-11/16	42.86

## Refrigeration Line Disconnections.

Reusable quick connect couplings are provided for field installation. If top condensing unit assembly must be removed the quick connect couplings can be disconnected and reused.

Before disconnecting refrigeration couplings:

- Disconnect power to merchandiser unit. This will allow refrigeration solenoid to close.
- Allow condensing unit to run until the condensing unit shuts off. This allows most of the refrigerant to be pumped into receiver tank.
- Disconnect power to top condensing unit.



## **Drain Line**

Connect the clear plastic drain line to the barbed fitting on the top of the condensate evaporator screen. Use the hose clamp provided to secure to fitting.

-Make an inspection on the condensate drain system at this time

-Check that the white PVC drain trap assembly is securely connected to the drain at the bottom of the case and has not come loose in shipment

-Check that the white PVC drain trap assembly is properly positioned in the inlet of the condensate pump.

-Check that the clear PVC tubing is connected to the pump and to the electric condensate evaporator barb fitting

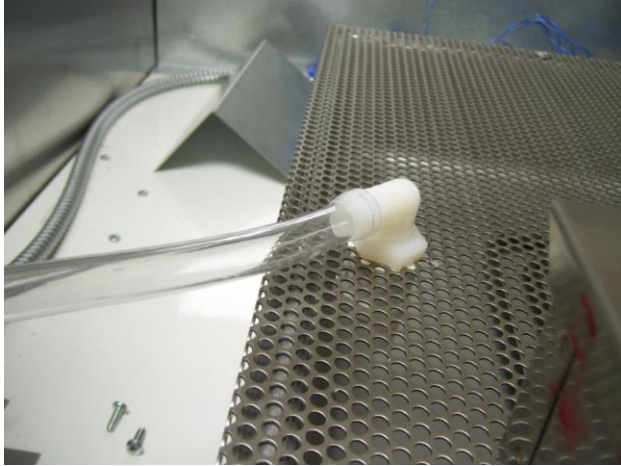

## **Replacement Parts**

DESCRIPTION	LMD4878 PART NUMBER	LMD7278 PART NUMBER	LMD9678 PART NUMBER
CONDENSING UNIT		30-20183	
CONDO PAN	40-19996	40-19996	40-19996
CONDO PAN HEATER	40-19996-1	40-19996-1	40-19996-1

# Top Condensing Unit Wiring

