



The Signature of Quality®

INSTALLATION & OPERATIONS INSTRUCTIONS
VRSS: Self-Contained & Remote Refrigerated Models
VNSS: Non-Refrigerated Displays





TABLE OF CONTENTS

Table of Contents.....	2
(1) Introduction	3
1.1 Serial Number.....	3
(2) Warning Labels & Safety Instructions	4
(3) Feature Identification.....	5
(4) Base Component Layout.....	7
(5) PRIOR TO UNPACKING EQUIPMENT!	8
(6) Installation instructions.....	9
6.1 Locating The Display Case	9
6.2 Removing Case From Shipping Skid	9
6.3 Single Case Installation (Stand alone units)	10
6.4 Installation for joined cases (Lineups).....	11
6.5 installation in an alcove.....	14
(7) Shelf installation and removal	15
7.1 Shelf brackets and supports	15
(8) Security Night Cover (Optional).....	17
(9) SLIDE-IN LEG & CASTER ADJUSTMENTS.....	19
(10) Electronic Temperature Control (Refrigerated units only)	21
(11) Initial Startup (Refrigerated units only)	24
(12) Cleaning Instructions.....	26
12.1 Daily Cleaning	26
12.2 Weekly Cleaning.....	26
12.3 Cleaning Condenser Coil (For non-reversing fan models only)	27
(13) Service	29
(14) Sale & Disposal.....	30
(15) Electrical and refrigeration specs	31
15.1 Cord Connected	31
(16) Wiring Diagram	33
16.1 VRSS Self Contained	33
16.2 VRSS Remote	33
16.3 VNSS.....	34
(17) VRSS Service Parts	35

(1) INTRODUCTION

Thank you for purchasing a Federal Industries display case. This manual contains important instructions for installing and servicing your new display case. A repair parts list and wiring diagram are also included in the manual. Read all of these documents carefully before installing or servicing your case.

	<p>NOTICE</p> <p>Read this manual before installing your case. Keep this manual and refer to it before doing any service on the equipment. Failure to do so could result in personal injury or damage to the case.</p>
	<p>NOTICE</p> <p>Installation and service of the electrical components in the case must be performed by a licensed electrician.</p> <p>The portions of this manual covering components contain technical instructions intended only for persons qualified to perform electrical work.</p>
	<p>DANGER</p> <p>Improper or faulty hookup of electrical components in the case can result in severe injury or death.</p> <p>All electrical wiring hookups must be done in accordance with all applicable local, regional, or national standards.</p>

1.1 SERIAL NUMBER

Record the model and serial numbers of the case for easy reference. Always refer to both model and serial numbers in your correspondence with Federal regarding the case.

Case Model _____ Serial Number _____

This manual cannot cover every installation, use, or service situation. If you need additional information, call or write us:

WARRANTY/TECHNICAL SERVICE DEPARTMENT

Parts Town
1200 Greenbriar Dr.
Addison, IL 60101
Toll Free: (833) 238-8168

Email: techservice@partstown.com



(2) WARNING LABELS & SAFETY INSTRUCTIONS

	<p>This is the safety-alert symbol. When you see this symbol on your case or in the manual, be alert to the potential for personal injury or damage to your equipment.</p>
---	---

Be sure you understand all safety messages and always follow recommended precautions and safe operating procedures.

	<p>NOTICE TO EMPLOYERS: You must make sure that everyone who installs, uses, or services your case is thoroughly familiar with all safety information and procedures.</p>
---	--

Important safety information is presented in this section and throughout the manual. The following signal words are used in the warning and safety messages:

DANGER:	Severe injury or death will occur if you ignore the message.
WARNING:	Severe injury or death can occur if you ignore the message.
CAUTION:	Minor injury or damage to your case can occur if you ignore the message.
NOTICE:	This is important installation, operation, or service information. If you ignore the message, you may damage your case.

 <p>CAUTION/ ATTENTION</p>	<p>RISK OF ELECTRIC SHOCK. DISCONNECT POWER BEFORE SERVICING UNIT</p> <p>RISQUE DE CHOC ÉLECTRIQUE COUPEZ LE COURANT AVANT L'UNITÉ D'ENTRETIEN</p>	<p>CAUTION/ATTENTION</p> <p>HAZARDOUS MOVING PARTS! DO NOT OPERATE UNIT WITH DISPLAY PANS REMOVED</p> <p>PIÈCES MOBILES DANGEREUSES! NE PAS UTILISER L'APPAREIL AVEC PLATEAUX ENLEVÉS</p>
---	--	--

The warning and safety labels shown throughout this manual are placed on your Federal Industries case at the factory. Follow all warning label instructions. If any warning or safety labels become lost or damaged, call our customer service department at (800) 356-4206 for replacements.

(3) FEATURE IDENTIFICATION

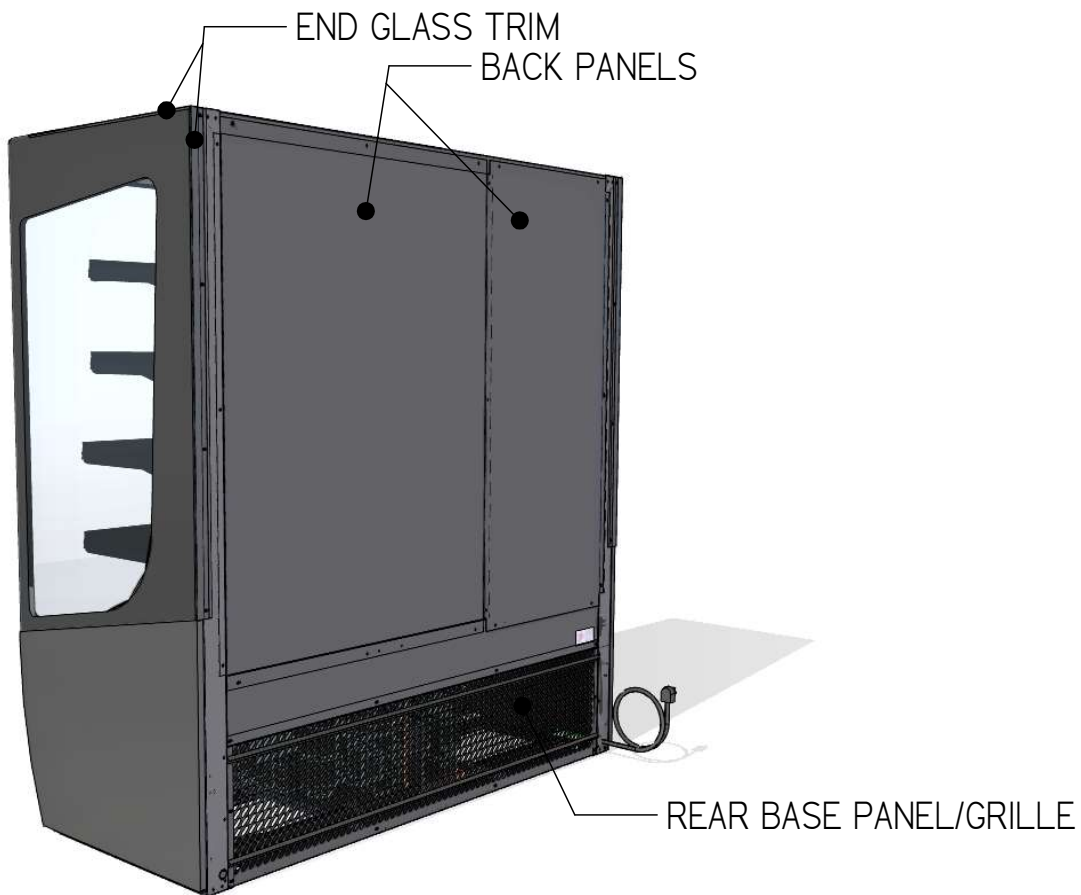
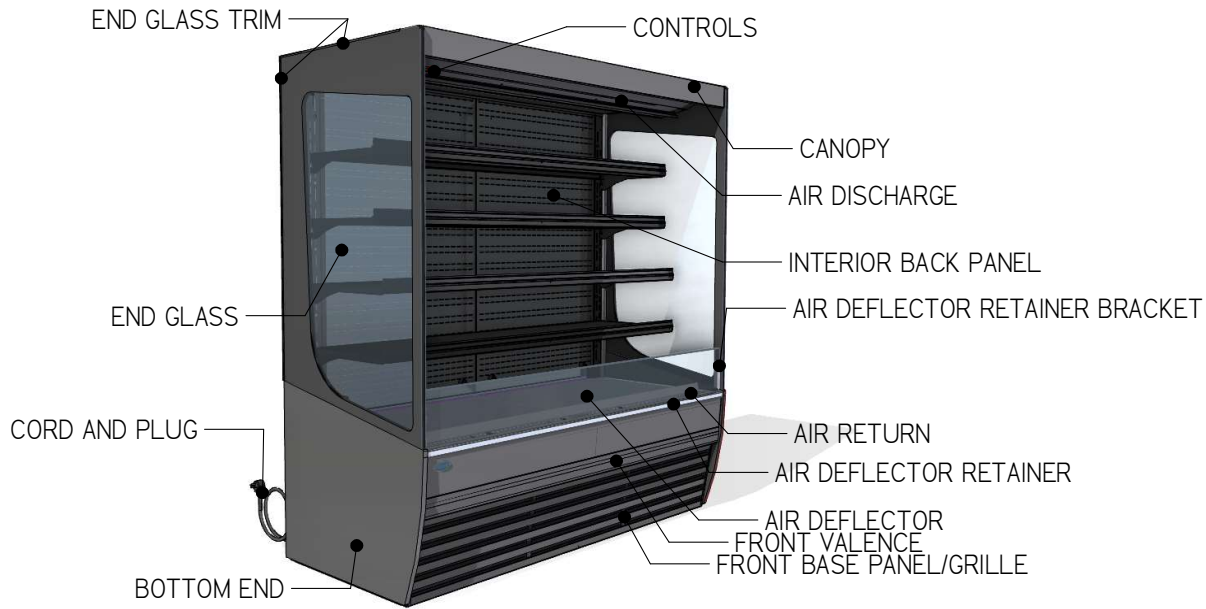

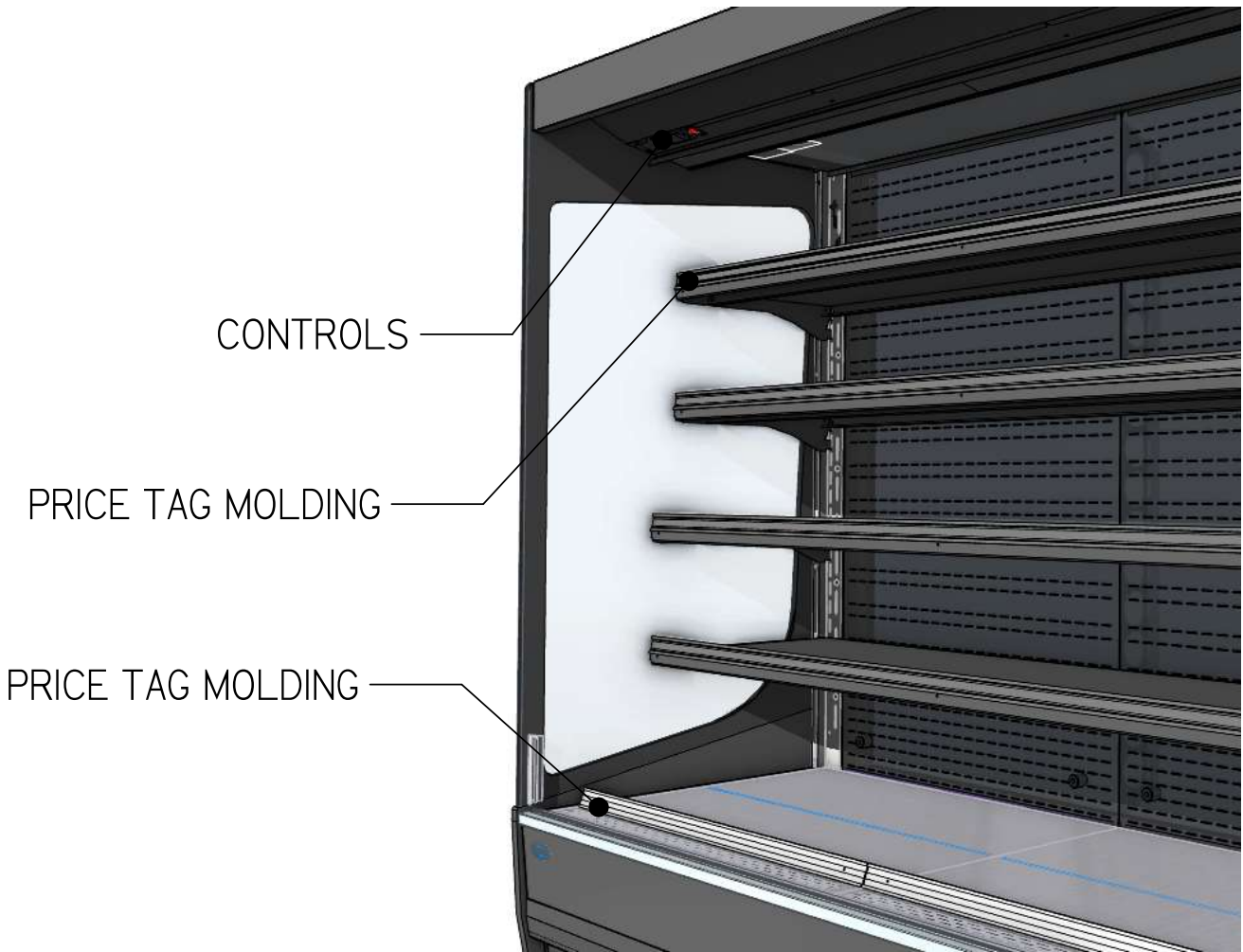

(4) BASE COMPONENT LAYOUT

VRSS3678 and VRSS3660 Self contained model shown. Other self-contained models are similar. Non-refrigerated units have no components in the base except power cord.

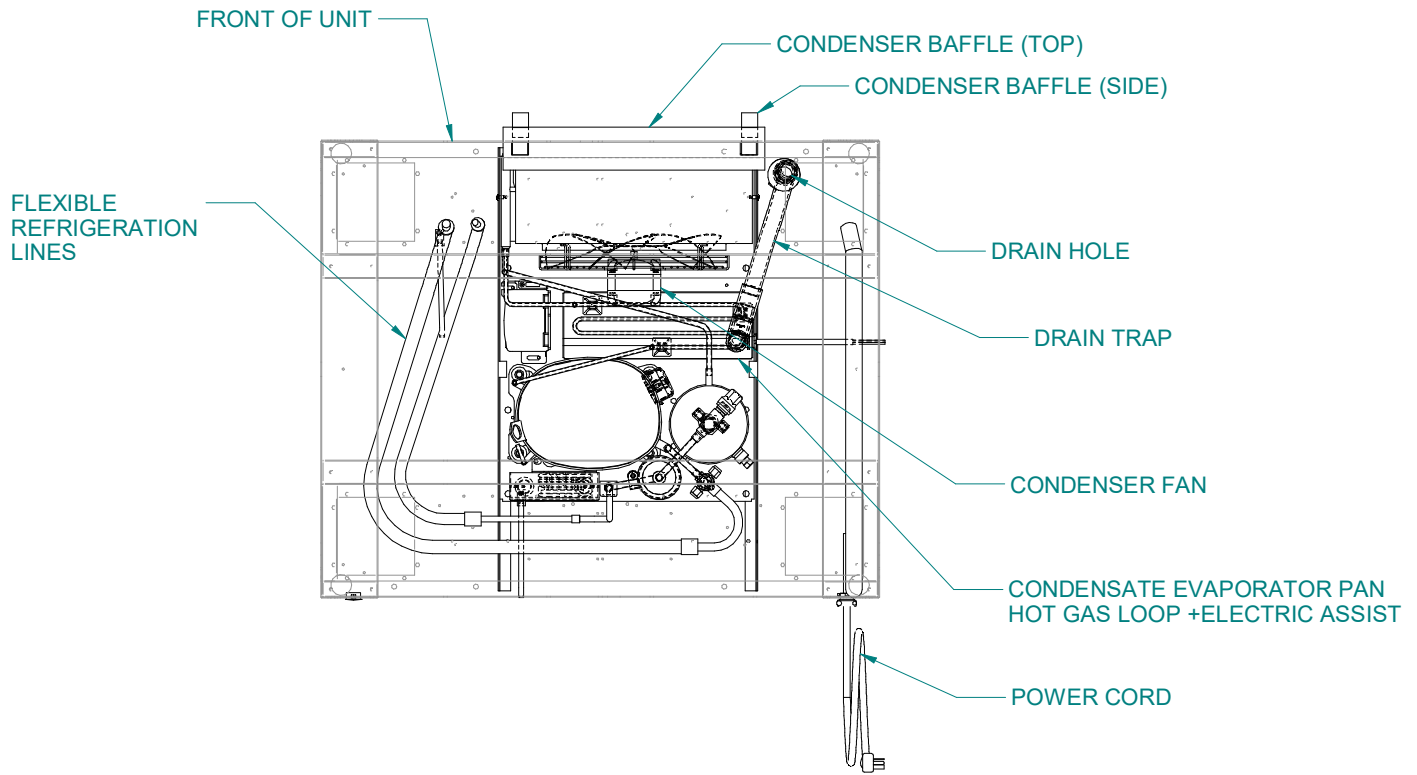

(5) PRIOR TO UNPACKING EQUIPMENT!

Inspect for shipping damage.

You are responsible for filing all freight claims with the delivering truck line. Inspect all cartons and crates for damage as soon as they arrive. If damage is noted to shipping crates, cartons, or if a shortage is found, note this on the bill of lading (all copies) prior to signing.

If damage is discovered when the case is uncrated, immediately call the delivering truck line and follow-up the call with a written report indicating concealed damage to your shipment. Ask for an immediate inspection of your concealed damaged item. Crating material must be retained to show the inspector from the truck line.

(6) INSTALLATION INSTRUCTIONS

6.1 LOCATING THE DISPLAY CASE



NOTICE

This refrigerated display case is designed to operate in a maximum environment of 80 DEG. F and 55% relative humidity. Exceeding these limits will cause poor case performance and sweating.

The case(s) should be located where it is not subjected to the direct rays of the sun, heating ducts, grills, radiator, or ceiling fans, nor should it be located near open doors or main door entrances. Also, avoid locations where there is excessive air movement or air disturbances and avoid high humidity locations such as near cases with water misting or fogging devices. Failure to locate this case as stated will reduce the performance of your display and will affect temperature of interior of case and product.

If this case or cases are to be located against a wall there should be at least 6" between the case and the wall to allow air circulation. Failure to give adequate space may cause exterior surfaces to sweat.

6.2 REMOVING CASE FROM SHIPPING SKID

Be sure to leave shelf packaging material intact for this step.

First remove the base front and rear panels

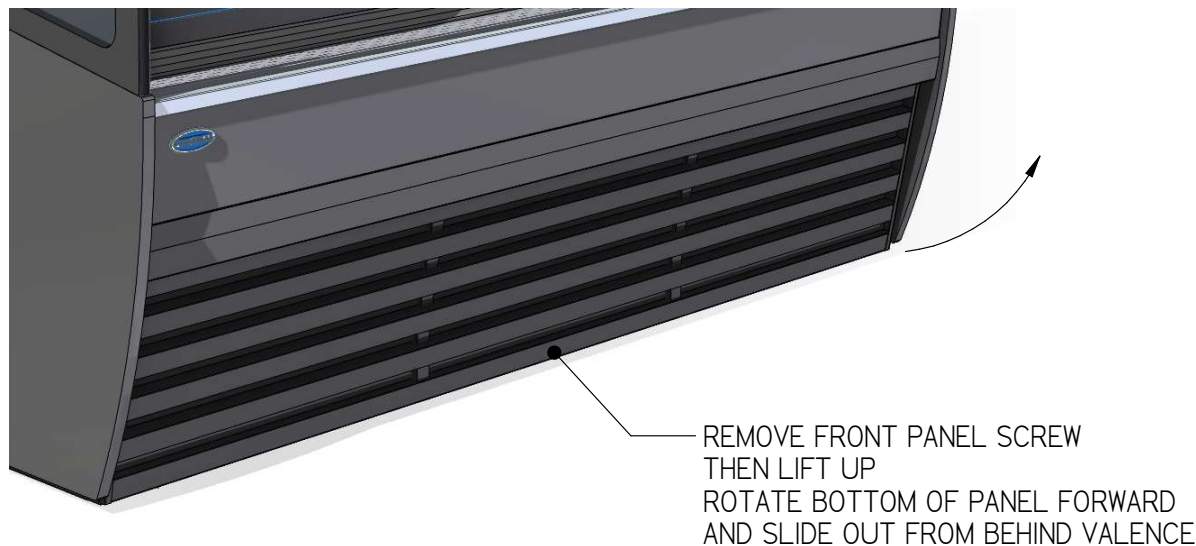

Two or more people should be involved in moving the unit from the pallet onto the ground.

Remove the (4) 1/4" screws that secure the case to the skid. These screws are located in the front and rear corners of the base rails. Base front and rear panels must be removed to access these bolts.

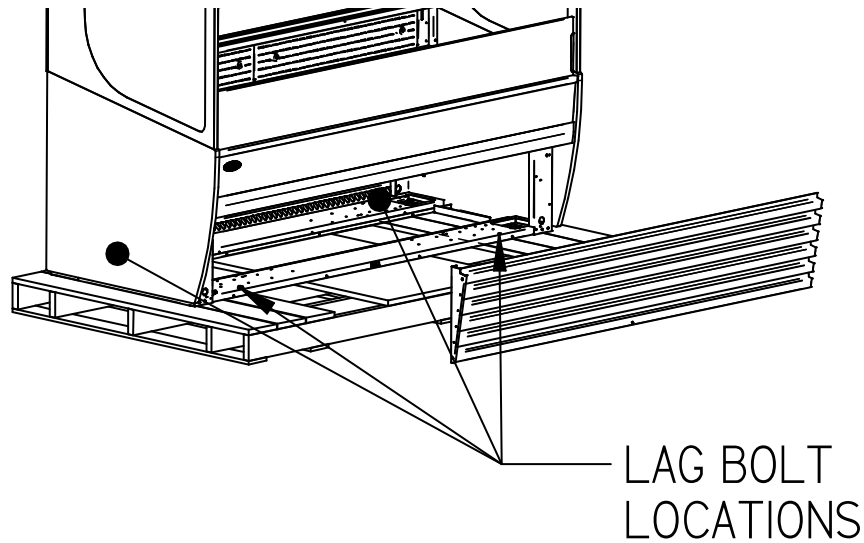

Once all the bolts are removed, slide the unit off the back of the shipping pallet, and tilt it so the rear corner touches the ground. Then have someone move pallet out from under the case and gently tilt the case forward until it touches the floor.

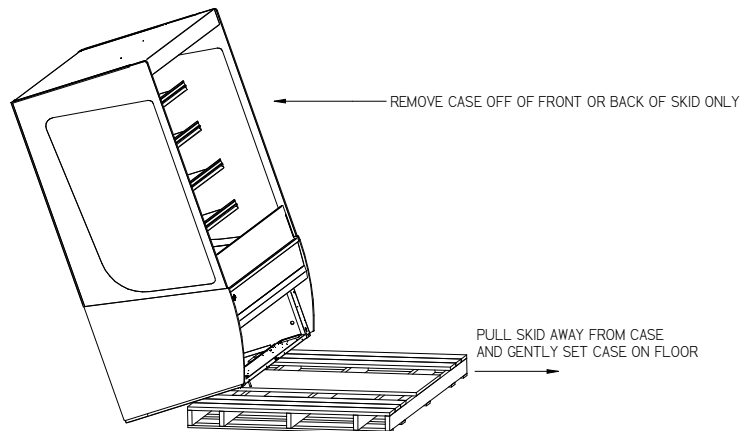

6.2.1 Removing Packaging Material

Remove bubble wrap and packing material for all shelves and panel, brackets, etc. If it is necessary to remove tape residue from plastic materials, use cleaning compounds recommended in the cleaning section of this manual.

Lifting and Moving the Case



Caution:

Do not push or pull against the glass air deflector on front of case. Doing so can cause the glass to break. Do not push or pull on side glass or pull on base panel. Doing so will break glass or pull out panel mounting screws. Care must be taken not to damage the case when removing it from the skid or moving the case.

6.3 SINGLE CASE INSTALLATION (STAND ALONE UNITS)

Leveling the Case

It is important that the case is level. This will allow for proper drainage of condensate water from evaporator coil. A wrench is included to aid in adjusting leg levelers.

Check the left-to-right level of the case along front of plastic air deflector retainer.

Check the front-to-rear level of the case along the interior ends of the case.

LEVEL CASE USING THESE SURFACES

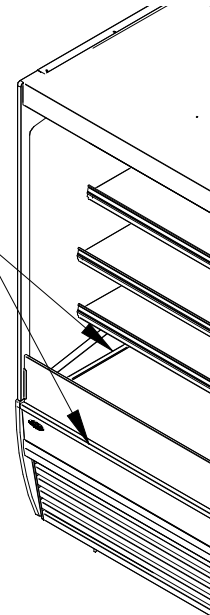

Adjust the (4) outside leg levelers as needed to level the case in each direction.

NOTE: If necessary, use a wood or plastic shim under each leg leveler to avoid scratching the tile floor.

Sealing Unit to The Floor

After the unit is positioned and the leg levelers are turned out, the unit needs to be sealed to the floor for NSF approved installation.

6.4 **INSTALLATION FOR JOINED CASES (LINEUPS)**

6.4.1 Join refrigerated to refrigerated

1. Remove all Shelves, display deck, interior back panel(s), exterior back(s), front and rear base panel, and loosen honeycomb (see cleaning section for honeycomb removal) material on the unfinished end to expose the holes used to bolt units together.
2. Position the right or left most unit in the desired position for the lineup to start, and level this case.
3. Push the 2nd case next to the 1st and line them up as closely as possible.
4. Adjust the leveling legs of the 2nd case until the units and joining holes align with each other.
5. Using (7) holes noted below, bolt units together with the supplied hardware, and attach joining trim to remove the gap between the decks in the joined units. Re-use the screws in the uprights, as well as the self-drilling screws provided with the kit.

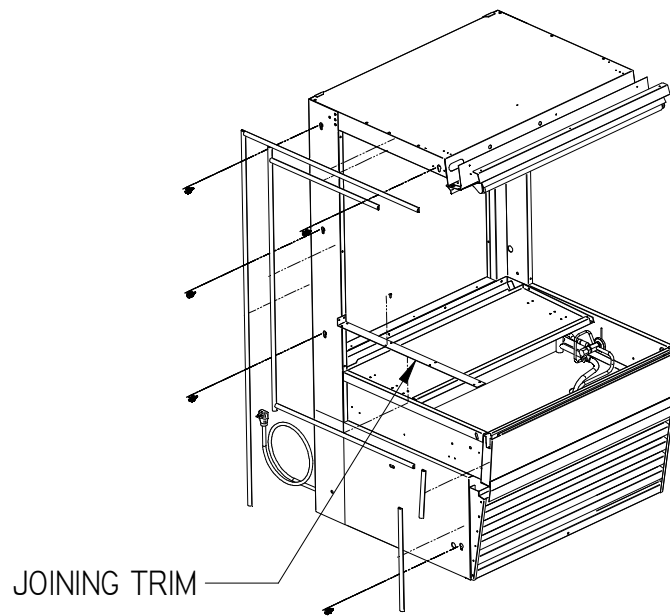
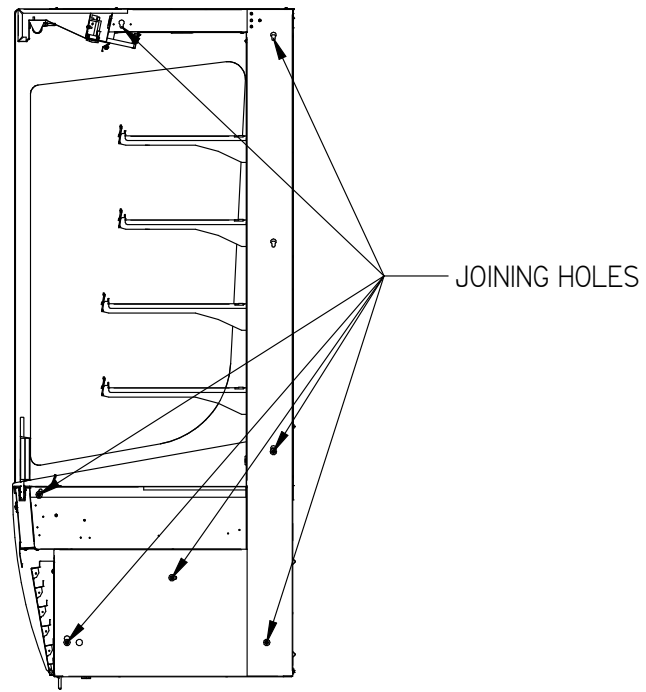

6. Replace all panels that were previously removed and re-insert honeycomb

6.4.2 Join units with glass divider, or join refrigerated to non-refrigerated

For this joining configuration, one unit will come with a lower end panel preinstalled with glass. Five bolt holes will be exposed on the outside of this panel and are the locations that will be used to join the units together. This kit also comes with top and rear exterior trim, but no interior trim.

1. Remove all Shelves, display deck, interior back panel(s), exterior back(s), front and rear base panel, and loosen honeycomb (see cleaning section for honeycomb removal) material on the unfinished end to expose the holes used to bolt units together.
2. Position the right or left most unit in the desired position for the lineup to start, and level this case.
3. Push the 2nd case next to the 1st and line them up as closely as possible.
4. Adjust the leveling legs of the 2nd case until the bolt holes align with the mating holes in the joining case.
5. Push the units together so that the through bolts go through the case to be joined.
6. Using the hardware provided (1/4-20 screw, washer, lock washer), screw the 2nd case with the unfinished end into the first case.

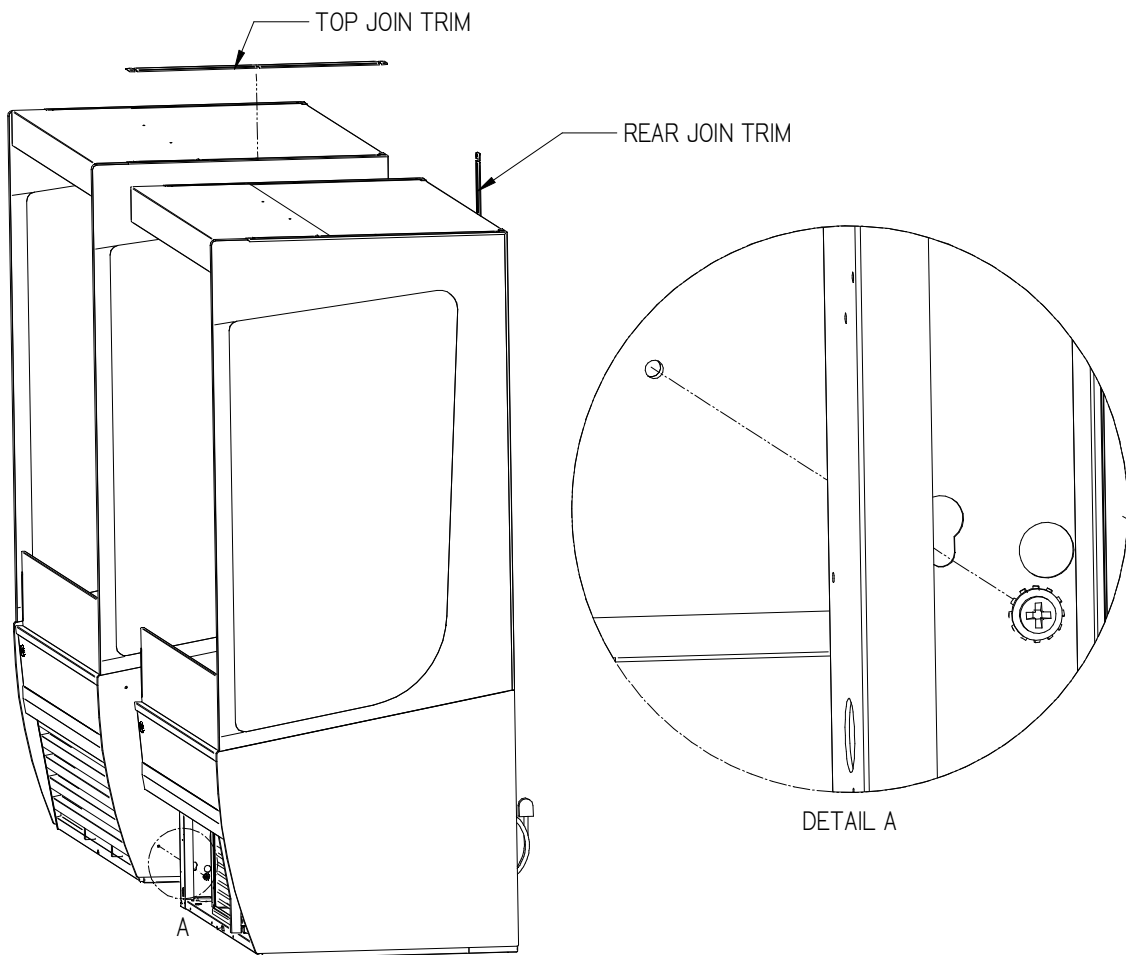

7. Finish the joining process loosening the glass trim on the case to slide the joining trim over the existing trim and the rear trim.

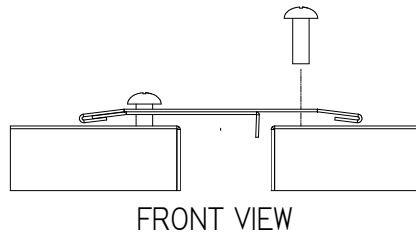

8. Replace any panels previously removed. Units are now joined.

6.5 INSTALLATION IN AN ALCOVE

When installing a case in an alcove make sure any signage above the case is sealed to prevent airflow from returning into the case.

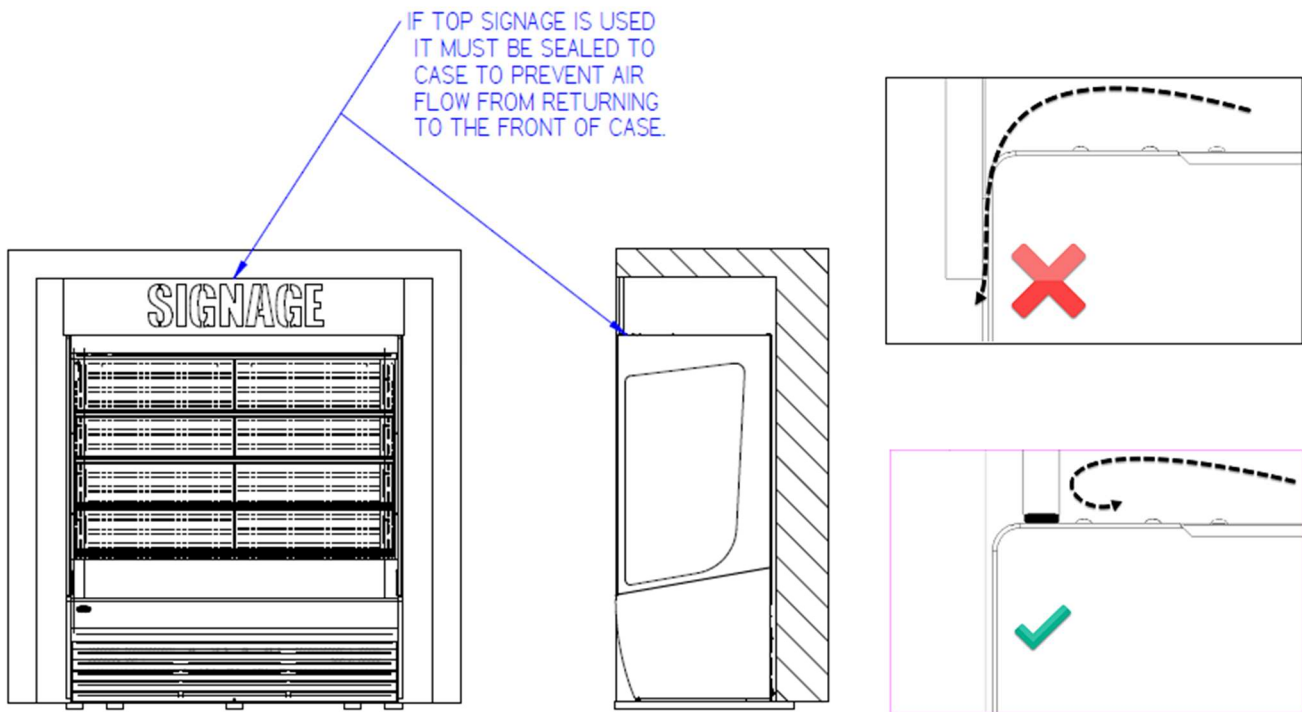

(7) SHELF INSTALLATION AND REMOVAL

7.1 SHELF BRACKETS AND SUPPORTS



NOTICE: Improper shelf configuration will cause performance issues

VRSS 78in tall units have two different shelf depths. The lower two shelves are longer, the upper two to three shelves are shorter. The longer shelves must be installed as the lowest shelves or the unit's air curtain will be disrupted and the unit will not maintain product temperature.

Shelves are pre-installed in the factory. To change shelf positions, remove the shelf, then shelf support, then brackets. Relocate the brackets to the desired shelf position. The left bracket and right bracket must be at the same height. This can be ensured by counting the position of the notch in the shelf standard. If you have shelf lights, the wire running to the light must be unplugged prior to moving the shelves. Note how the wire is run through the shelf support, and shelf.

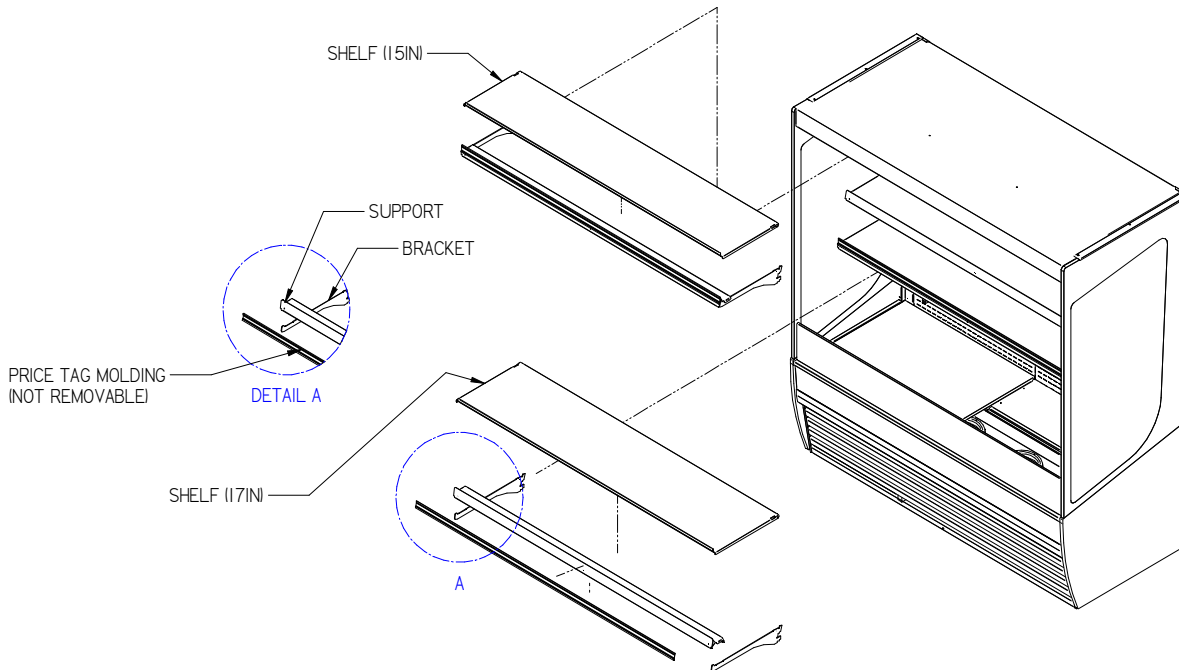

The diagram below illustrates how to straighten or angle the shelves. To angle the bracket, be sure to have the top hook of the bracket in its slot and to pull up while rotating down to the most extreme downward position. To angle the shelf, first angle both brackets, and install the shelf as normal.

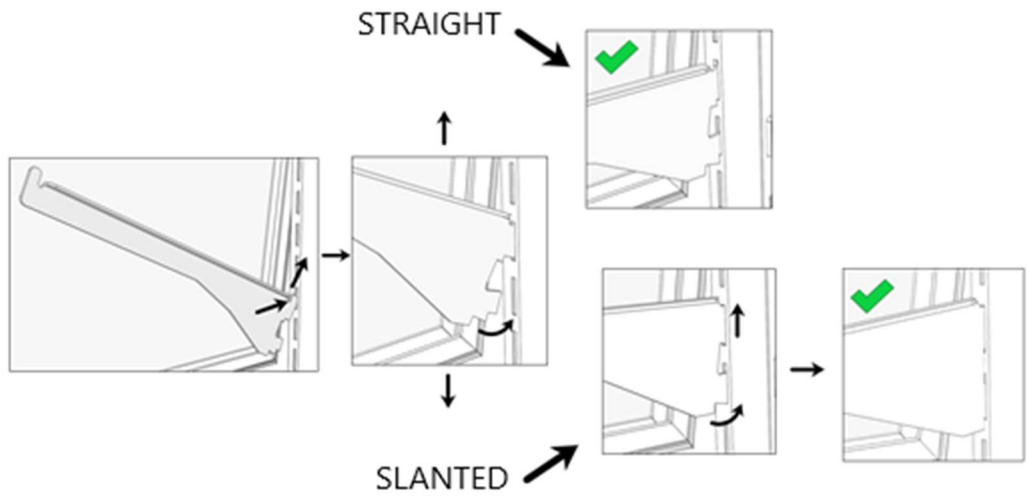

(8) SECURITY NIGHT COVER (OPTIONAL)

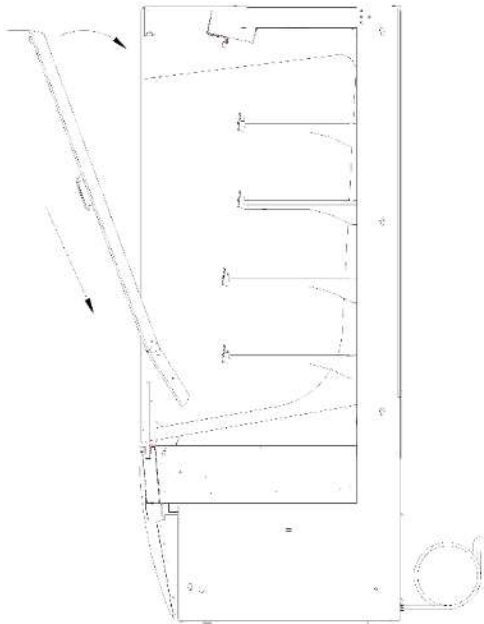

1. Install the security cover into the preinstalled retaining brackets by first inserting the bottom with the top of the cover tilted out.
2. Insert the bottom of the security cover into the lower u-clip retainer by rotating the top of the assembly in toward the case, and dropping the cover down into place.
3. The top of the cover will sit against the upper retainer bracket.
4. Once the cover is in position, lock the latches using the key in both sides of the security cover panel.

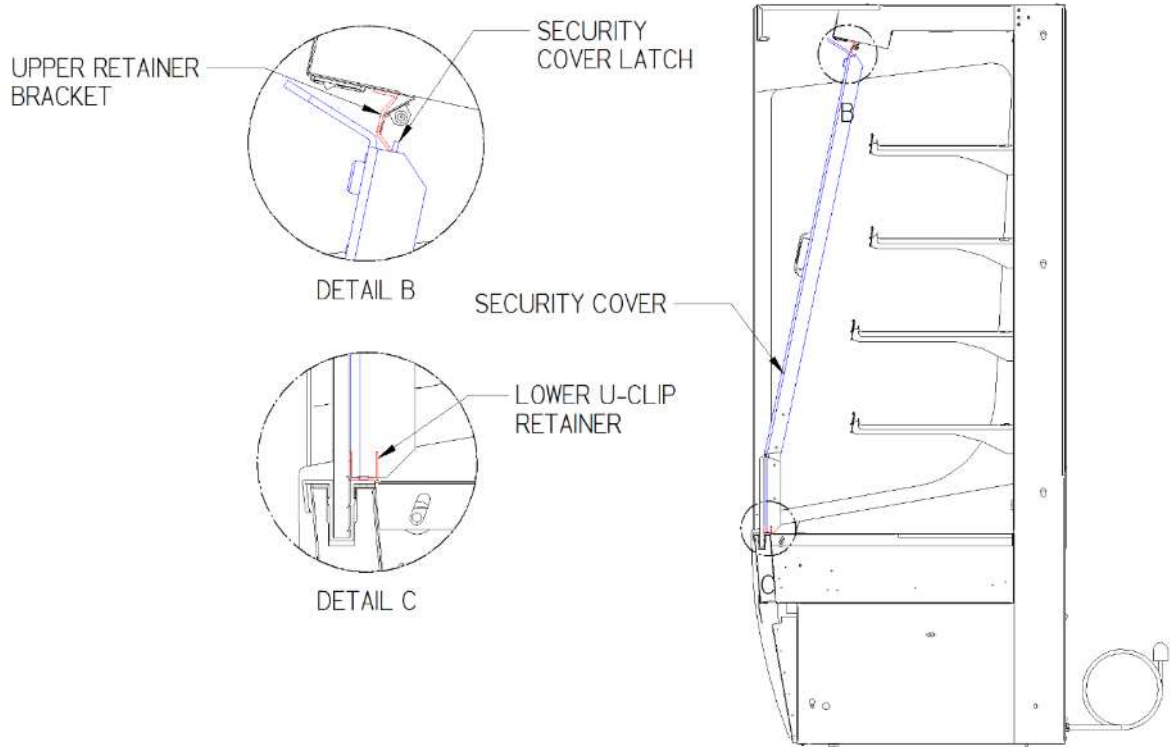

When installing the security cover panel, ensure that the bottom of the panel is seated in the lower u-clip, and that the latch fully engages behind the upper retaining bracket.

(9) SLIDE-IN LEG & CASTER ADJUSTMENTS

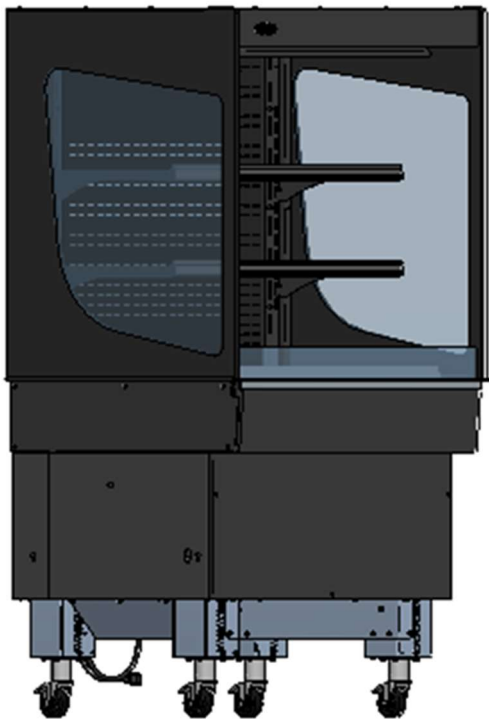
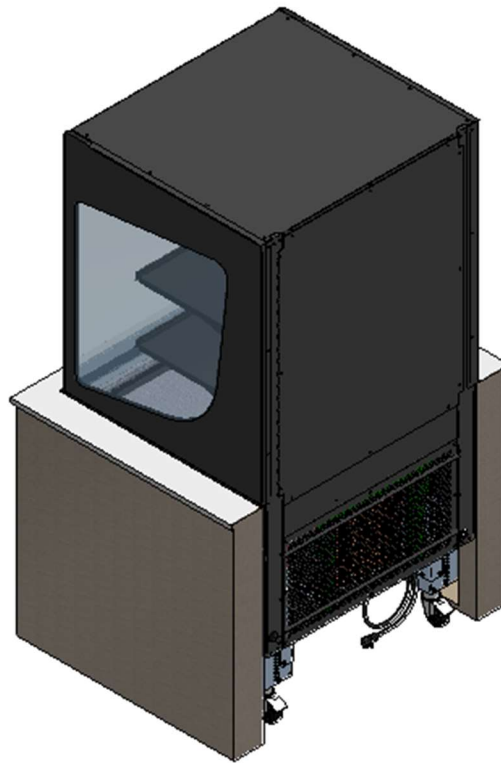
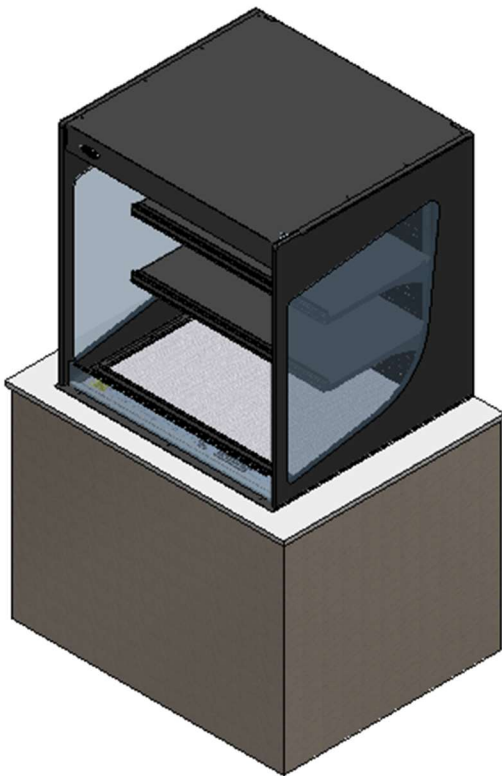

Slide In Models

Designed to slide/roll into a counter with an open back.

Refrigerated cases are available with rear condenser air intake and discharge only.

Case counter height is set at 34" from the factory.

Leg assemblies are adjustable in 1/4" increments.

Adjustable casters have 1" of upward adjustment to fine tune height to match counter surfaces.

Casters are double locking in swivel and roll directions.

The next page shows common counter height adjustments.

*****IMPORTANT*****

CASE MUST BE LIFTED AND SECURED TO ADJUST CASTER/LEG ASSEMBLIES.

*****WARNING*****

FAILURE TO DO SO CAN CAUSE SEVERE INJURY OR DEATH.

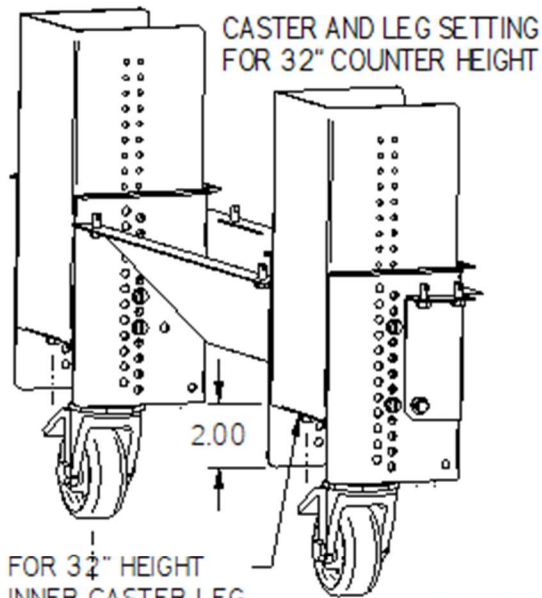

FOR 32" HEIGHT
INNER CASTER LEG
IS RECESSED INTO
OUTER SLEEVE 2"

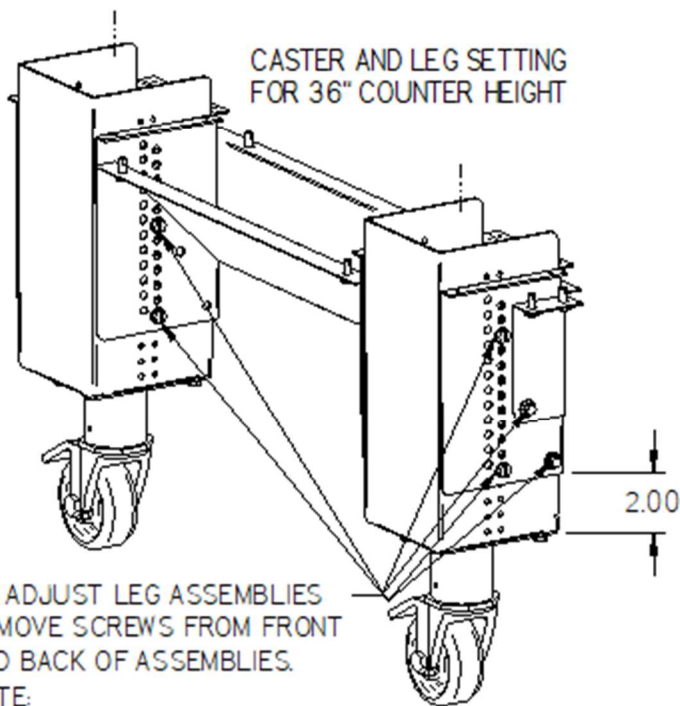
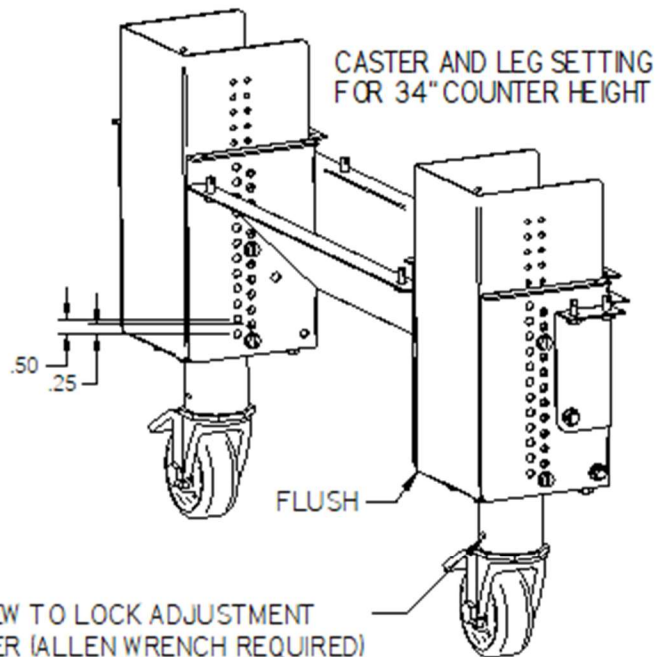

TO ADJUST LEG ASSEMBLIES
REMOVE SCREWS FROM FRONT
AND BACK OF ASSEMBLIES.

NOTE:

LEG ASSEMBLIES ARE ADJUSTABLE IN 1/4" INCREMENTS
CASTERS HAVE 1" OF UPWARD ADJUSTMENT.

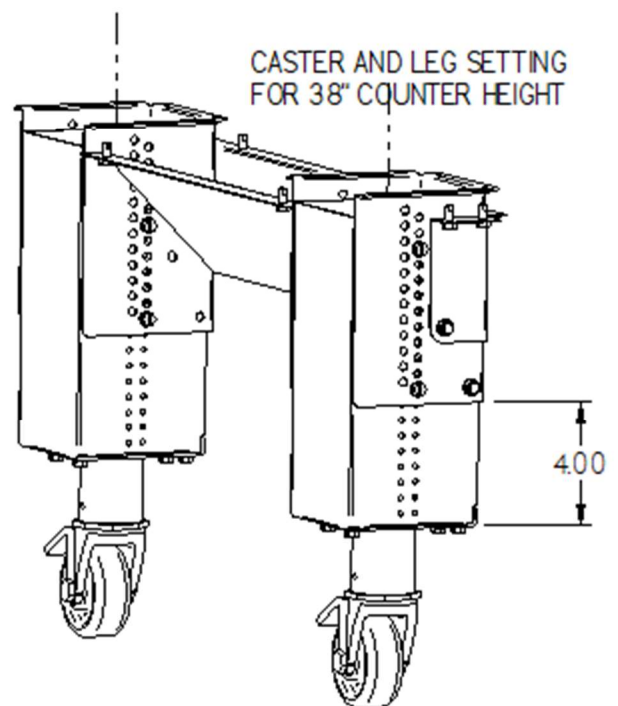





IMPORTANT

CASE MUST BE LIFTED AND SUPPORTED WHEN ADJUSTING
CASTER LEG ASSEMBLIES.

WARNING



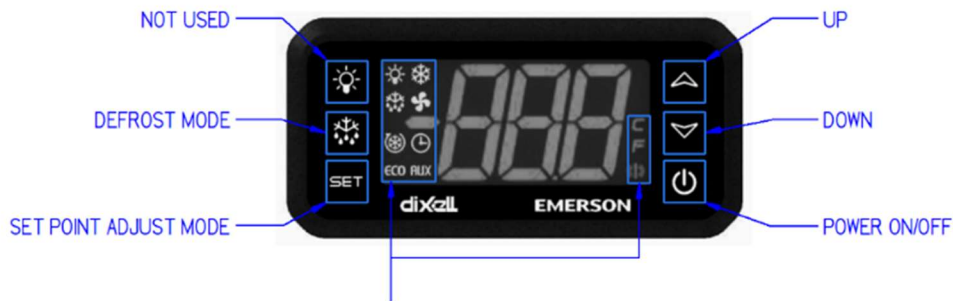

FAILURE TO DO SO CAN CAUSE INJURY OR DEATH

(10) ELECTRONIC TEMPERATURE CONTROL (REFRIGERATED UNITS ONLY)

	Power on/off: Press and hold to turn system on or off.
SET	Set: Press and hold to enter the set point adjustment menu.
	Defrost: Press and hold to initiate a manual defrost.
	Up: Change set points when in set point adjustment menu. When not in set point menu, shows maximum temperature of the display probe.
	Down: Change set points when in set point adjustment menu. When not in set point menu, shows minimum temperature of the display probe.



Display indication symbols

	On	Compressor on
	Flashing	Minimum compressor off time in progress
	On	Unit in defrost mode
	Flashing	Defrost delay
	On	Condenser fan running
	Flashing	Minimum condenser fan off time in progress
	On	Alarm occurring. See error code section below.
°C/°F	On	Indicates temperature unit of measure.

10.1.1 Powering on control

To turn refrigeration control power on, press and hold “⏻” for approx. three seconds. When the control powers on, the display will read the cabinet probe temperature. The compressor and condenser fan run indicators (* & ✨) will illuminate on the display, meaning that the compressor and condenser fan are running. (Note: the control may already be in the on mode when shipped from factory).

To turn refrigeration control power to off, press and hold “⏻” for approx. three seconds. When the control powers off the display will read “OFF”. When refrigeration control is in the off-mode cabinet lights and evaporator fans will still operate, but the compressor will not turn on causing the case to gradually reach room temperature.

10.1.2 Adjusting the set point

The set point is what determines how cold the display case will hold food and beverage. To adjust the set point press the “SET” button. Then press “▲” button to increase the set point number (colder) or press the “▼” button to decrease the set point number (warmer). There are nine (9) available set points numbers, the higher the number of the set point, the colder the display case will run, with setting “9” being the coldest and setting “1” being the warmest. Once you have chosen your desired setting press the “SET” button again to confirm your choice. The control cutout temperature for the selected setpoint will briefly be displayed if the setpoint was changed.

10.1.3 Entering manual defrost mode

The control is programmed to automatically initiate a defrost by two different methods, involving time and temperature, as outlined in the “Defrost Cycle” section (Pg.) of “ELECTRONIC CONTROL PARAMETERS AND EXPLANATION OF OPERATION.” While it is uncommon that the automatic defrost cycles would insufficiently defrost the case, a Manual Defrost mode is available if this situation arises.

Note: The control will not allow the initiation of a manual defrost within 30 minutes of completion of another defrost cycle, manual or automatic.

To initiate a manual defrost press and hold the “❄️” button approx. three seconds. The defrost is initiated when the defrost mode indicator ❄️ illuminates on the display. The control display will then return to reading the probe temperature. When the defrost mode indicator ❄️ turns off the defrost is complete and the compressor will turn back on automatically and the compressor and condenser fan indicator will be shown (* & ✨).

10.1.4 Error codes

It is possible for error codes to be displayed on the control screen. In the event of a malfunction an alarm will sound and the alarm indicator 📢 will be displayed. An error code or codes will flash intermittently on the display. If there are multiple codes, the display will continuously cycle through them.

Mute: You may mute the alarm by pressing any button. The red alarm symbol 📢 and all error codes will still be displayed. When the fault is remedied, the control will return to normal operation and will automatically clear the codes from the display.

Display	Description	Cause	Resolution
"P1"	Air discharge temperature probe failure	Probe signal is interrupted or short-circuited	<ul style="list-style-type: none"> • Check to ensure probe wires and quick disconnect are secure in control. • Check probe resistance to table below. If 0 resistance is present, check wiring insulation. If infinite resistance is present, check for breaks in wiring (meter will likely read overload or very high in the mega-ohm range). • Ensure that probes are wired per the wiring diagram provided. Replace probe if other remedies fail, or if probe resistance deviates from "Table 3" below.
"P2"	Defrost temperature probe failure		

TEMPERATURE PROBE COMMON RESISTANCE CHART			
Probe Temp	Maximum Resistance [kΩ]	Normal Resistance [kΩ]	Minimum Resistance [kΩ]
32°F(0°C)	27.83	27.28	26.74
77°F(25°C)	10.1	10	9.9
212°F(100°C)	1	0.97	0.94

(11) INITIAL STARTUP (REFRIGERATED UNITS ONLY)



NOTICE

This refrigerated display case is designed to operate in a maximum environment of 80 DEG. F and 55% relative humidity. Exceeding these limits will cause poor case performance and sweating.

1. Prior to initial startup be sure to clean the case as described in the “Weekly Cleaning” section of the manual.
2. Be sure that display deck(s) and shelves are in the desired locations.
3. Be sure front and rear base panels are in place and secured.
4. Plug in the unit to the appropriate wall outlet and turn unit’s power switch (marked “POWER”) to the on or “I” position.
5. If the control reads “OFF” then press and hold the control’s power button to turn it on.
6. In a few moments the refrigeration system will turn on.
7. Use the switch labeled “LIGHT” to turn on all top/shelf lights.

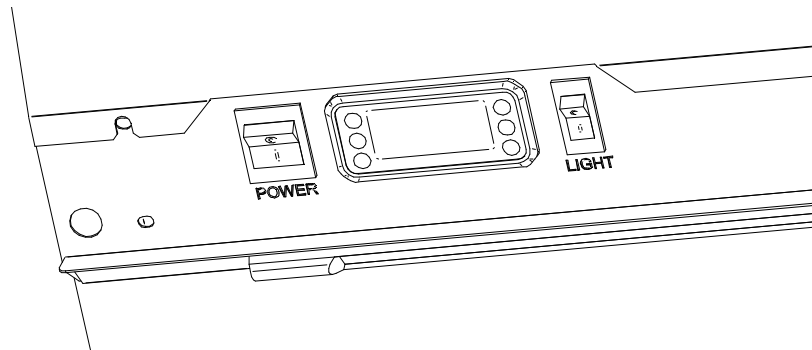

For more detailed information on control operation see the section “Electronic Temperature Control”

At start up from a warm unit, it is recommended that the temperature control is set to a mid-setting, such as 5. After the unit has gone through several cycles, adjust the control to a warmer or a colder setting if necessary, to maintain desired product temperature. Allow refrigerated models to run for at least two hours before placing pre-chilled product into display area.

11.1.1 Placing Product into Case



NOTICE





CASE MUST BE STOCKED WITH PRE-CHILLED PRODUCT 38° OR COLDER.

- Do not exceed 150 pounds of weight per shelf. Heavy product should be distributed evenly across the entire shelving area.
- Determine desired shelving location before placing product in case. Product must be removed to readjust shelf location.
- Allow a minimum of 2" between top of product and bottom of next shelf up.
- Do not overhang the front or rear of shelves with product. Improper clearance in front and rear of shelf will block the refrigerated airflow and will cause product loss.
- Do not block the slots along the front and rear air discharge slots. Covering these slots will block the refrigerated airflow and could cause product loss.
- Allow refrigerated models to run for at least two hours before placing pre-chilled (38°F or less) product into unit.

(12) CLEANING INSTRUCTIONS

12.1 DAILY CLEANING

The case should be cleaned thoroughly, as described in the weekly cleaning section before it is used for the first time.

	<p>NOTICE: Avoid splashing or soaking any electrical components with water to prevent electrical damage to the case.</p>
	<p>NOTICE: Shut off lights, disconnect power and remove all products from case. Allow sufficient time for the unit to reach room temperature before proceeding with cleaning.</p>
	<p>NOTICE: Remove all products from the case before proceeding with cleaning procedure.</p>
	<p>NOTICE: This case is not designed to be cleaned by flushing.</p>





Note: For major spills or foreign material buildup perform the weekly cleaning instructions.

Note: Detergents are not recommended and do not use abrasive cleaners or pads to prevent scratching of surfaces.

1. Clean all foreign materials from the door opening.
2. Wipe complete interior of both the upper & lower areas of case using a damp cloth.
3. The remaining exterior surface should be wiped down using any ammoniated cleaners or soapy warm water.

12.2 WEEKLY CLEANING

This procedure is recommended on a weekly basis. It may need to be performed more often if necessary to maintain a clean, sanitary case. The case should be cleaned to this procedure before using the first time.

	<p>NOTICE:</p> <p>Avoid splashing or soaking any electrical components with water to prevent electrical damage to the case.</p>
	<p>NOTICE:</p> <p>Shut off lights, disconnect power and remove all products from case. Allow sufficient time for the unit to reach room temperature before proceeding with cleaning.</p>
	<p>NOTICE:</p> <p>Remove all products from the case before proceeding with cleaning procedure.</p>
	<p>NOTICE:</p> <p>This case is not designed to be cleaned by flushing.</p>

1. Side, and rear door glass can be cleaned with common window cleaners.
2. Remove interior shelving and display deck from unit as described in the “Shelving Installation and Removal” section of this manual.
3. Clean all shelves, shelf supports, shelf light deflectors, shelf brackets, shelf standards using warm soapy water and a brush. Rinse thoroughly and allow to dry.
4. Remove the display deck and clean using warm soapy water and a brush. Rinse thoroughly and allow to dry.
5. Clean the entire interior of the case using warm soapy water. Wipe off all soapy water with a damp cloth and allow to dry. (DO NOT use solvents such as Acetone, Benzene, Carbon Tetrachloride, and Lacquer Thinners)
6. Reassemble all components in reverse order.
7. The exterior surfaces should be wiped down using any ammoniated cleansers or warm soapy water.

12.3 CLEANING CONDENSER COIL (FOR NON-REVERSING FAN MODELS ONLY)

Note that this section is only intended for those units without the reversing fan feature.

	<p>NOTICE:</p> <p>Condenser coil must be cleaned a minimum of twice per month to ensure proper refrigeration performance and prevent compressor failure. In some environments, it may be necessary to clean more frequently. FAILURE TO CLEAN CONDENSER COIL WILL VOID COMPRESSOR WARRANTY.</p>
---	---

It is very important that the Condenser coil is cleaned monthly to ensure proper refrigeration performance and to prevent compressor failure. Failure to clean condenser coil will void condenser warranty.

The condenser must be cleaned from the front of the case.

1. Disconnect power to the unit.
2. Remove the front panels located on the base or condenser compartment of unit.
3. Carefully vacuum the front surface of condenser coil. Take care not to bend coil fins with vacuum cleaner nozzle.
4. Reinstall all panel and retaining screws and reconnect power.

(13) SERVICE

Service Information

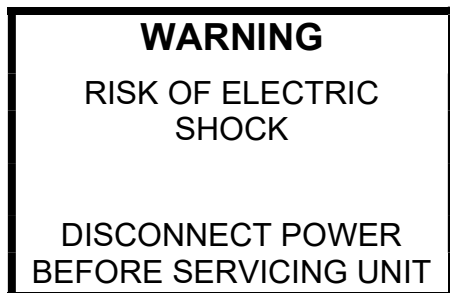

Before any service work is performed on the case, make sure all power is disconnected to the case.

To find a service company in your area, please visit our website at <https://federalind.com/support-service/service-rep-locator>. There you can also find self-service tools to help you get the answers you need faster!

For warranty service requests and all technical support, including compressors and other service parts please contact:

- Phone: (833) 238-8168
- Email: techservice@partstown.com



Federal Industries has partnered with Parts Town for ALL Non-Warranty Part Identification, Pricing, Lead Times, Orders & Freight Quotes. Please contact Parts Town directly if you need parts:

- Website: PartsTown.com
- Email: CustomerService@PartsTown.com
- Phone: 833-809-8188

(14) SALE & DISPOSAL

14.1 OWNER RESPONSIBILITY

If you sell or give away your Federal Industries case you must make sure that all safety labels and the Installation-Service Manual are included with it. If you need replacement labels or manuals, Federal Industries will provide them free of charge. Contact the customer service department at Federal Industries at (800) 356-4206.

The customer service department at Federal Industries should be contacted at the time of sale or disposal of your case so records may be kept of its new location. Electrical and refrigeration specs

(15) ELECTRICAL AND REFRIGERATION SPECS



WARNING:

Improper or faulty hookup of electrical components in the display case can result in severe injury or death.

15.1 CORD CONNECTED

All standard models are supplied with a power cord that is properly sized to the amperage requirements of the case. See the rating plate for specific unit requirements. This can be located as shown in the “FEATURE IDENTIFICATION” section of this manual. The cord is factory installed protruding from the bottom rear corner of the case. A separate circuit for each display case is required to prevent other appliances on the same circuit from overloading the circuit and causing malfunction.

MODEL	ELECTRICAL 2 WIRE + GROUND	SELF CONTAINED					REMOTE							
		STANDARD CONNECTION CORD & PLUG			REFRIGERANT	C.U. HP	CONDENSATE REMOVAL	SHIP WEIGHT	PERMANENT CONNECT		REFRIGERANT	BTU'S @ + 20°	CONDENSATE REMOVAL	SHIP WEIGHT
		AMPS	MAX FUSE SIZE	NEMA CORD &					AMPS	MAX FUSE SIZE				
VRSS3660S	120/60/1	12.7	20	NEMA 5-20P	R449A	3/4	INTEGRATED PAN	535	2.5	15	R449A	6,720	PUMP	490
								243						222
VRSS4860S	208-240/60/1	12.5	20	NEMA 6-20P	R449A	1	INTEGRATED PAN	620	3.0	15	R449A	9,580	PUMP	580
								281						263
VRSS6060S	208-240/60/1	13.5	20	NEMA 6-20P	R449A	1-1/4	INTEGRATED PAN	755	3.5	15	R449A	11,200	PUMP	710
								342						322
VRSS7260S	208-240/60/1	13.7	20	NEMA 6-20P	R449A	1-1/4	INTEGRATED PAN	845	3.5	15	R449A	12,300	PUMP	800
								383						363

VRSS 60in High

MODEL	ELECTRICAL 2 WIRE + GROUND	SELF CONTAINED					REMOTE							
		STANDARD CONNECTION CORD & PLUG			REFRIGERANT	C.U. HP	CONDENSATE REMOVAL	SHIP WEIGHT	PERMANENT CONNECT		REFRIGERANT	BTU'S @ + 20°	CONDENSATE REMOVAL	SHIP WEIGHT
		AMPS	MAX FUSE SIZE	NEMA CORD &					AMPS	MAX FUSE SIZE				
VRSS3678S	120/60/1	12.7	20	NEMA 5-20P	R449A	3/4	INTEGRATED PAN	740	2.5	15	R449A	6,720	PUMP	695
								336						315
VRSS4878S	208-240/60/1	12.5	20	NEMA 6-20P	R449A	1	INTEGRATED PAN	820	3.0	15	R449A	9,580	PUMP	775
								372						351
VRSS6078S	208-240/60/1	13.5	20	NEMA 6-20P	R449A	1-1/4	INTEGRATED PAN	1030	3.5	15	R449A	11,200	PUMP	985
								467						447
VRSS7278S	208-240/60/1	13.7	20	NEMA 6-20P	R449A	1-1/4	INTEGRATED PAN	1080	3.5	15	R449A	12,300	PUMP	1040
								490						472

VRSS 78in High

MODEL	STANDARD CONNECTION CORD & PLUG			SHIP WEIGHT
	2 WIRE + GROUND		NEMA CORD & PLUG	
	120/60/1	AMPS		
VNSS3660S	1.5	15	NEMA 5-15P	445
				202
VNSS4860S	1.5	15	NEMA 5-15P	535
				243
VNSS6060S	2.0	15	NEMA 5-15P	665
				302
VNSS7260S	2.0	15	NEMA 5-15P	755
				342

VNSS 60in High

MODEL	STANDARD CONNECTION CORD & PLUG			SHIP WEIGHT
	2 WIRE + GROUND		NEMA CORD & PLUG	
	120/60/1	AMPS		
VNSS3678S	1.5	15	NEMA 5-15P	655
				297
VNSS4878S	1.5	15	NEMA 5-15P	735
				333
VNSS6078S	2.0	15	NEMA 5-15P	940
				426
VNSS7278S	2.0	15	NEMA 5-15P	995
				451

VNSS 78in High



CAUTION

Risk of Electric Shock. If the cord or plug becomes damaged, replace only with a cord and plug of the same type.

Cord Connected (STANDARD)

- A factory installed power cord is properly sized to the amperage requirements of the case. See the electrical data plate located on the rear exterior of the case for the proper circuit size for each case.
- The cord is factory installed protruding from the rear corner of the case.
- A separate circuit for each display case is required to prevent other appliances on the same circuit from overloading the circuit and causing malfunction.

Refrigerated Permanent Connected (REMOTE REFRIGERATED MODELS ONLY)

- Only a licensed electrician must perform all case electrical connections.
- All electrical wiring hookups must be done in accordance with all applicable local, regional, or national electrical standards.
- A separate circuit for each display case is required to prevent other appliances on the same circuit from overloading the circuit and causing malfunction.
- The electrical service must be grounded upon installation.
- See the electrical data plate located at the rear of the case for proper circuit size and wire ampacity.
- The electrical connection box is accessible from the rear of the case with rear grill removed. See grill removal section of this manual for grill removal procedure.

(16) WIRING DIAGRAM

16.1 VRSS SELF CONTAINED

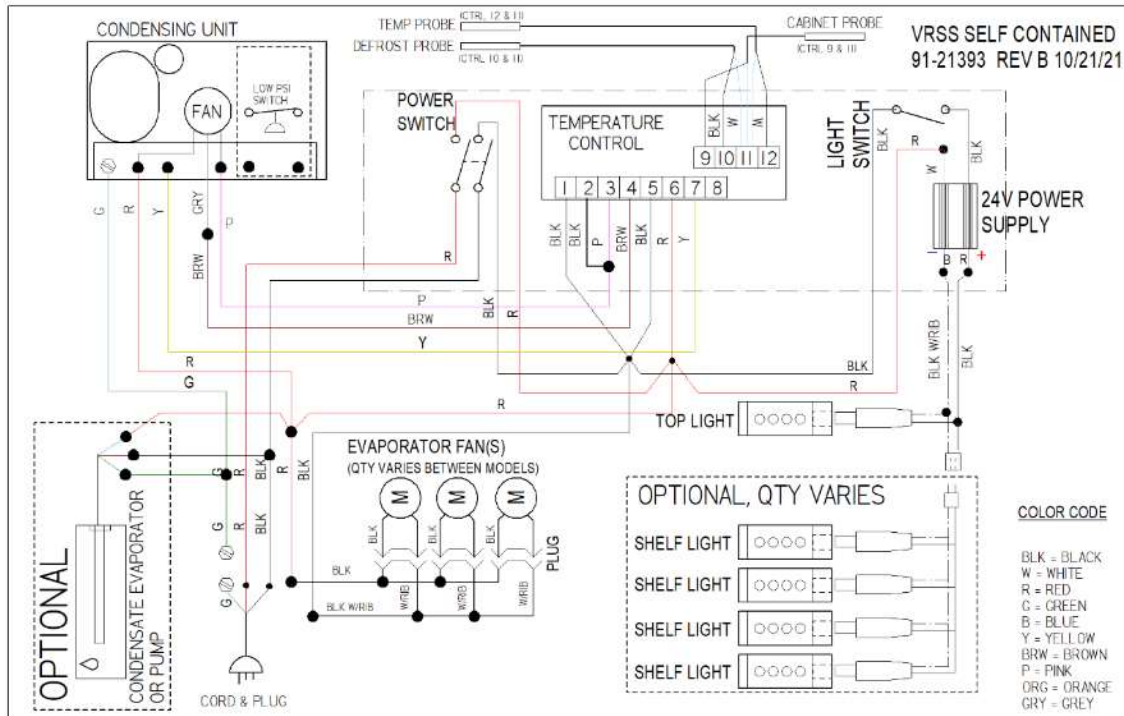

16.2 VRSS REMOTE

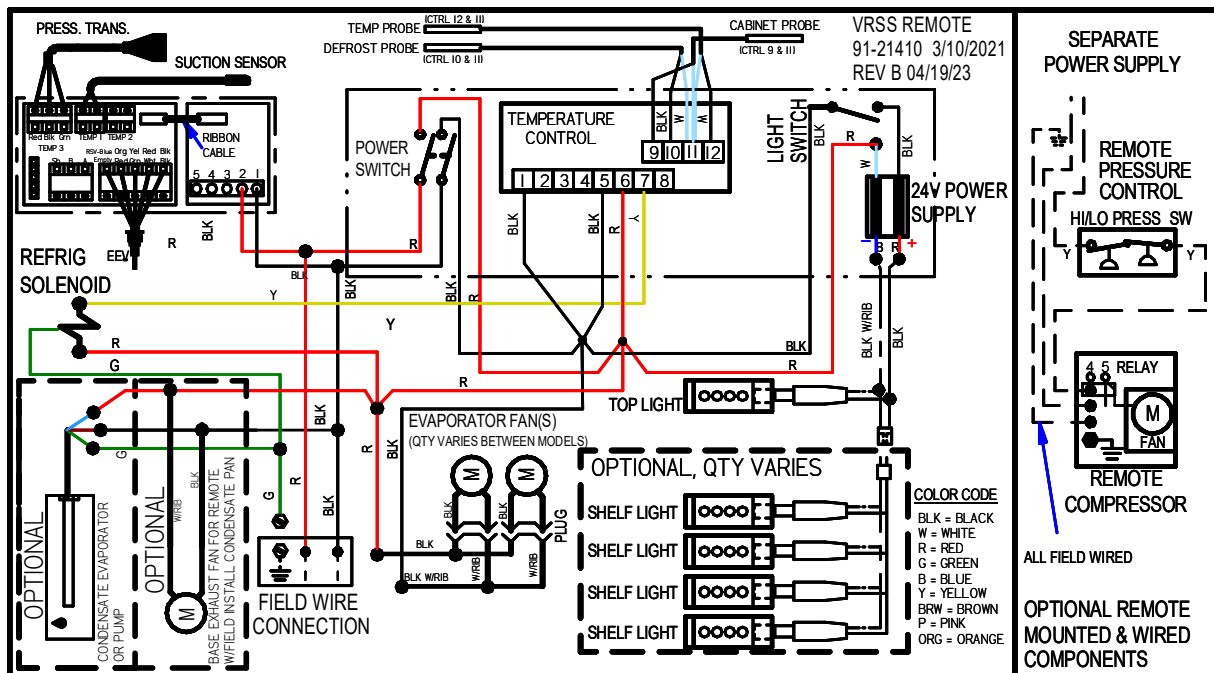

16.3 VNSS

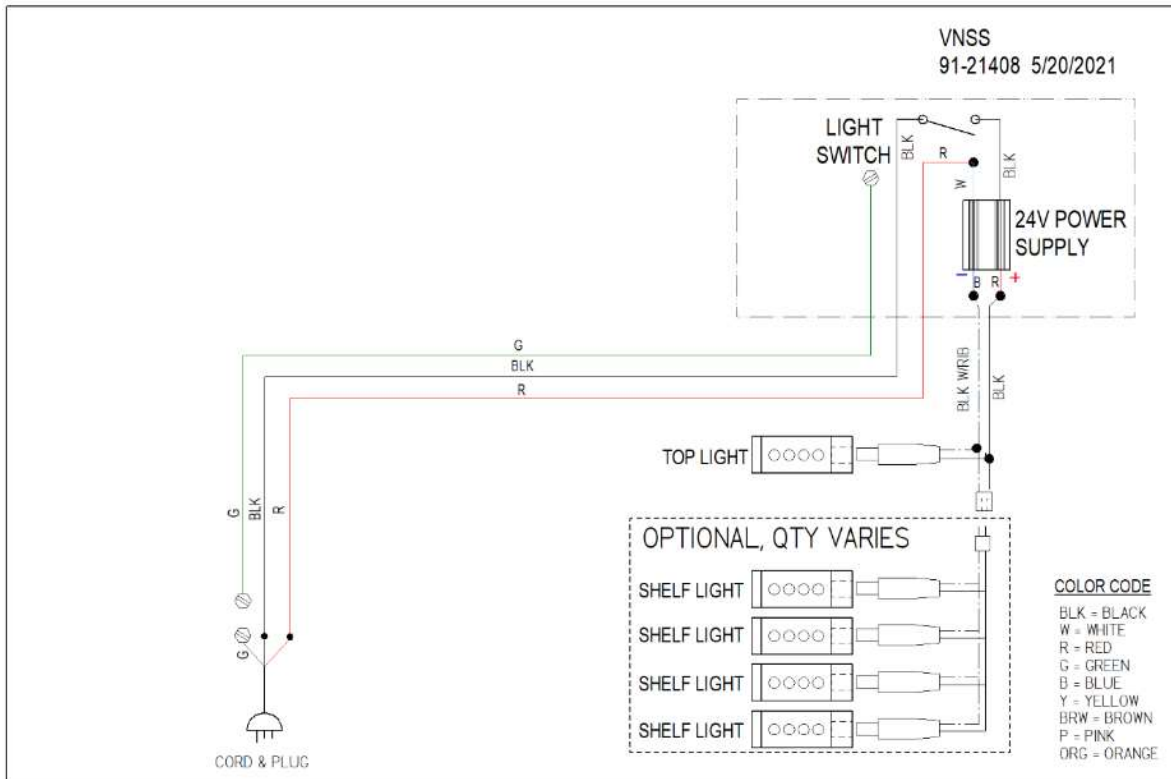

(17) VRSS SERVICE PARTS

ELECTRICAL COMPONENTS		QTY	QTY	QTY	QTY	QTY	QTY	QTY	QTY
	PART#	3678	4878	6078	7278	3660	4860	6060	7260
POWER CORD, 120V	43-20569	1	---	---	---	1	---	---	---
POWER CORD, 240V	43-19457	---	1	1	1	---	1	1	1
TEMP. CONT. (NON-REVERSING FAN)	32-21342-17	1	1	1	1	1	1	1	1
TEMP. CONT. (REVERSING FAN)	32-21342-18	1	1	1	1	1	1	1	1
TEMPERATURE PROBE	32-19094	2	2	2	3	3	2	2	3
TEMPERATURE PROBE (DEFROST IF USED)	32-19866	1	1	1	---	---	1	1	---
SWITCH,ROCKER POWER 22A	41-18186	1	1	1	1	1	1	1	1
SWITCH,ROCKER LIGHT22A	41-1066	1	1	1	1	1	1	1	1
HARNESS,SHELF LIGHTS	43-21333	1	1	1	1	1	1	1	1
POWER SUPPLY 24V 100W	39-20555	1	1	1	1	1	1	1	1
TOP LIGHT	42-20871-30C35	1	---	---	---	1	---	---	---
	42-20871-42C35	---	1	---	---	---	1	---	---
	42-20871-54C35	---	---	1	---	---	---	1	---
	42-20871-66C35	---	---	---	1	---	---	---	1
TAPE, TOP LIGHT LED, DOUBLE SIDED (QTY PER LED)	90-20985	60in (.047 ROL)	84in (.066 ROL)	102in (.079 ROL)	126in (0.098 ROL)	60in (.047 ROL)	84in (.066 ROL)	102in (.079 ROL)	126in (0.098 ROL)
SHELF LIGHTS	42-20871-25C35	4	---	---	---	2	---	---	---
	42-20871-38C35	---	4	---	---	---	2	---	---
	42-20871-54C35	---	---	4	---	---	---	2	---
	42-20871-66C35	---	---	---	4	---	---	---	2
TAPE, SHELF LIGHT LED, DOUBLE SIDED (QTY PER LED)	90-20985	49in (.038 ROL)	70in (.054 ROL)	102in (.079 ROL)	126in (0.098 ROL)	49in (.038 ROL)	70in (.054 ROL)	102in (.079 ROL)	126in (0.098 ROL)
REFRIGERATION		QTY	QTY	QTY	QTY	QTY	QTY	QTY	QTY
		3678	4878	6078	7278	3660	4860	6060	7260
FAN MOTOR, BLADE, CORD, AND VENTUR	41-21237-16	1	2	2	3	1	2	2	3
FAN HARNESS	43-21501	---	1	2	2	---	1	2	2
TXV FOR 60 AND 72IN (SELF CONTAINED)	32-21063	---	---	1	1	---	---	1	1
TXV FOR 36 AND 48IN (SELF CONTAINED)	32-20874	1	1	---	---	1	1	---	---
EEV (REMOTE)	32-21228	1	---	---	---	1	---	---	---
EEV (REMOTE)	32-21226	---	1	1	1	---	1	1	1
EEV PRESSURE TRANSDUCER (REMOTE)	32-21225	1	1	1	1	1	1	1	1
COIL, EVAPORATOR, 36IN	33-21288-1	1	---	---	---	1	---	---	---
COIL, EVAPORATOR, 48IN	33-21288-2	---	1	---	---	---	1	---	---
COIL, EVAPORATOR, 60IN	33-21288-3	---	---	1	---	---	---	1	---
COIL, EVAPORATOR, 72IN	33-21288-4	---	---	---	1	---	---	---	1
FILTER DRIER (REPLACEMENT)	32-12391	1	1	1	1	1	1	1	1
COMPRESSOR, 36IN	30-21479	1	---	---	---	1	---	---	---
COMPRESSOR, 48IN	30-21478	---	1	---	---	---	1	---	---
COMPRESSOR, 60IN AND 72IN	30-21454	---	---	1	1	---	---	1	1
CONDENSING UNIT, 36IN	30-21316	1	---	---	---	1	---	---	---
CONDENSING UNIT, 48IN	30-21317	---	1	---	---	---	1	---	---
CONDENSING UNIT, 60IN AND 72IN	30-21318	---	---	1	1	---	---	1	1
CONDENSATE HEATER 400W 120V	40-21439-1	1	---	---	---	1	---	---	---
CONDENSATE HEATER 600W 230V	40-19392	---	1	1	1	---	1	1	1
FLEX REFRIGERATION LINE - STANDARD	82-21384-1	---	1	---	---	---	1	---	---
	82-21384-2	---	---	1	1	1	---	1	1
	82-21385-1	1	---	---	---	1	---	---	---
	82-21386-1	1	---	---	---	1	---	---	---
	82-21386-2	---	1	1	1	---	1	1	1
FLEX REFRIGERATION LINE - RAID	82-21384-1	---	1	1	1	---	1	1	1
(REAR AIR INTAKE AND DISCHARGE)	82-21384-2	1	---	---	---	1	---	---	---
	82-21386-1	1	---	1	1	1	---	1	1
	82-21386-2	---	1	---	---	---	1	---	---

MISC COMPONENTS		QTY	QTY	QTY	QTY	QTY	QTY	QTY	QTY
		3678	4878	6078	7278	3660	4860	6060	7260
LEG LEVELER,1/2-13 X 2.5	65-21273	4	4	4	4	4	4	4	4
AIR DIFFUSER, 36IN	W11823-1	1	---	---	---	1	---	---	---
AIR DIFFUSER, 48IN	W11823-2	---	1	---	---	---	1	---	---
AIR DIFFUSER, 60IN	W11823-3	---	---	2	---	---	---	2	---
AIR DIFFUSER, 72IN	W11823-4	---	---	---	2	---	---	---	2
PVC TUB FITTING FOR COPPER AND	84-21557	2	2	2	2	2	2	2	2
FITTING NUT	84-21558	2	2	2	2	2	2	2	2
FITTING GASKET	84-21559	2	2	2	2	2	2	2	2
SPRAY FOAM SEALANT	22-21574	1	1	1	1	1	1	1	1
DRAIN ASSY,TUBE,STANDARD	SA-1513	1	---	---	---	1	---	---	---
	SA6092	---	1	---	---	---	1	---	---
	SA6092-2	---	---	---	2	---	---	---	2
	SA6092-3	---	---	---	---	---	---	---	---
DRAIN ASSY,TUBE,RAID REAR AIR IN	SA6092-1	---	---	2	---	---	---	2	---
DRAIN ASSY,TUBE,REMOTE W/PUM	SA6103	1	1	---	---	1	1	---	---
DRAIN ASSY,TUBE,REMOTE W/PUM	SA6103-	---	---	2	2	---	---	2	2
THERMOPLASTIC DRAIN	84-70225	1	1	2	2	1	1	2	2
DRAIN WASHER	M-6229	1	1	2	2	1	1	2	2
AIR DEFLECTOR	51-21305-1	1	---	---	---	---	---	---	---
	51-21305-2	---	1	---	---	---	---	---	---
	51-21305-3	---	---	1	---	---	---	---	---
	51-21305-4	---	---	---	1	---	---	---	---
	51-21305-11	---	---	---	---	1	---	---	---
	51-21305-12	---	---	---	---	---	1	---	---
	51-21305-13	---	---	---	---	---	---	1	---
	51-21305-14	---	---	---	---	---	---	---	1
AIR DEFLECTOR FOR CASES W/ROLL	51-21305-5	1	---	---	---	---	---	---	---
	51-21305-6	---	1	---	---	---	---	---	---
	51-21305-7	---	---	1	---	---	---	---	---
	51-21305-8	---	---	---	1	---	---	---	---
	51-21305-15	---	---	---	---	1	---	---	---
	51-21305-16	---	---	---	---	---	1	---	---
	51-21305-17	---	---	---	---	---	---	1	---
	51-21305-18	---	---	---	---	---	---	---	1
AIR DEFLECTOR SLIDE-IN 60" TALL CA	51-21305-21	---	---	---	---	1	---	---	---
	51-21305-22	---	---	---	---	---	1	---	---
	51-21305-23	---	---	---	---	---	---	1	---
	51-21305-24	---	---	---	---	---	---	---	1
AIR DEFLECTOR SLIDE-IN W/ROLL CO	51-21305-25	---	---	---	---	1	---	---	---
	51-21305-26	---	---	---	---	---	1	---	---
	51-21305-27	---	---	---	---	---	---	1	---
	51-21305-28	---	---	---	---	---	---	---	1
NIGHT CURTAIN	65-19300	1	---	---	2	1	---	---	2
	65-21374	---	1	---	---	---	1	---	---
	65-19458	---	---	2	---	---	---	2	---
SECURITY COVER (OPTIONAL) (COVE	SA6084-1B	1	---	---	---	---	---	---	---
	SA6084-2B	---	1	---	---	---	---	---	---
	SA6084-3B	---	---	2	---	---	---	---	---
	SA6084-4B	---	---	---	2	---	---	---	---
	SA6084-11B	---	---	---	---	1	---	---	---
	SA6084-12B	---	---	---	---	---	1	---	---
	SA6084-13B	---	---	---	---	---	---	2	---
	SA6084-14B	---	---	---	---	---	---	---	2
BASE FRONT GRILLE ASSEMBLY VISIC	SA6018-1B	1	---	---	---	1	---	---	---
	SA6018-2B	---	1	---	---	---	1	---	---
	SA6018-3B	---	---	1	---	---	---	1	---
	SA6018-4B	---	---	---	1	---	---	---	1
BASE FRONT PANEL SLIDE-IN	M21797-1B	---	---	---	---	1	---	---	---
	M21797-2B	---	---	---	---	---	1	---	---
	M21797-3B	---	---	---	---	---	---	1	---
	M21797-4B	---	---	---	---	---	---	---	1
DECAL, CAUTION ELECTRICAL SHOCK	91-12340	1	1	1	1	1	1	1	1
LOGO,FEDERAL	91-72523	1	1	1	1	1	1	1	1

<u>GLASS END PANELS VISION</u>		
	LEFT	RIGHT
END GLASS PANELS SQUARE CLEAR 60" TALL		
BLACK	50-21330-2B	50-21330-2B
END GLASS PANELS SQUARE REFLECTIVE 60" TALL		
BLACK	50-21330-12LB	50-21330-12RB
END GLASS PANELS SQUARE CLEAR 78" TALL		
BLACK	50-21330-1B	50-21330-1B
END GLASS PANELS SQUARE REFLECTIVE 78" TALL		
BLACK	50-21330-11LB	50-21330-11RB
END GLASS PANELS CURVED CLEAR 60" TALL		
BLACK	50-21299-2B	50-21299-2B
END GLASS PANELS CURVED REFLECTIVE 60" TALL		
BLACK	50-21299-12LB	50-21299-12RB
END GLASS PANELS CURVED CLEAR 78" TALL		
BLACK	50-21299-1B	50-21299-1B
END GLASS PANELS CURVED REFLECTIVE 78" TALL		
BLACK	50-21619-11LB	50-21619-11RB

<u>END PANELS SLIDE-IN</u>		
	LEFT	RIGHT
END GLASS PANELS SQUARE CLEAR		
BLACK	50-21605-2B	50-21605-2B
END GLASS PANELS SQUARE REFLECTIVE		
	50-21605-12LB	50-21605-12RB
END GLASS PANELS CURVED CLEAR		
BLACK	50-21619-2B	50-21619-2B
END GLASS PANELS CURVED REFLECTIVE		
	50-21619-12LB	50-21619-12RB
END PANELS FOR SOLID END STRAIGHT PROFILE LAMINATED, 60IN HEIGHT		
BLACK	68-21623-23L	68-21623-23R
WHITE	68-21623-26L	68-21623-26R
END PANELS FOR SOLID END CURVED PROFILE LAMINATED, 60IN HEIGHT		
BLACK	68-21622-23L	68-21622-23R
WHITE	68-21622-26L	68-21622-26R

END PANELS

END PANELS FOR UNITS WITH END GLASS AND NO LAMINATE

	LEFT	RIGHT
BLACK	68-21300-1LB	68-21300-1RB
WHITE	68-21300-1LW	68-21300-1RW
STAINLESS	68-21300-15L	68-21300-15R

END PANELS FOR UNITS WITH END GLASS AND WITH LAMINATE

	LEFT	RIGHT
BLACK	68-21300-2LB	68-21300-2RB
WHITE	68-21300-2LW	68-21300-2RW

END PANELS FOR SOLID END STRAIGHT PROFILE AND NO LAMINATE, 60IN HEIGHT

	LEFT	RIGHT
BLACK	68-21331-23L	68-21331-23R
WHITE	68-21331-26L	68-21331-26R

END PANELS FOR SOLID END STRAIGHT PROFILE AND NO LAMINATE, 78IN HEIGHT

	LEFT	RIGHT
BLACK	68-21331-13L	68-21331-13R
WHITE	68-21331-16L	68-21331-16R

END PANELS FOR SOLID END CURVED PROFILE AND NO LAMINATE, 60IN HEIGHT

	LEFT	RIGHT
BLACK	68-21301-23L	68-21301-23R
WHITE	68-21301-26L	68-21301-26R

END PANELS FOR SOLID END CURVED PROFILE AND NO LAMINATE, 78IN HEIGHT

	LEFT	RIGHT
BLACK	68-21301-13L	68-21301-13R
WHITE	68-21301-16L	68-21301-16R

SHELVING			
SHELF PARTS FOR 78IN, TOP 2-3 15IN DEEP SHELVES FOR 36IN LONG UNITS			
COLOR	BRACKET (NEED TWO)	SUPPORT	SHELF
BLACK	67-21387-1B	M21488-1B	M21487-11B
WHITE	67-21387-1W	M21488-1W	M21487-11W
STAINLESS	67-21387-1S	M21488-1S	M21487-11S
SHELF PARTS FOR 78IN, TOP 2-3 15IN DEEP SHELVES FOR 48IN LONG UNITS			
COLOR	BRACKET (NEED TWO)	SUPPORT	SHELF
BLACK	67-21387-1B	M21488-2B	M21487-12B
WHITE	67-21387-1W	M21488-2W	M21487-12W
STAINLESS	67-21387-1S	M21488-2S	M21487-12S
SHELF PARTS FOR 78IN, TOP 2-3 15IN DEEP SHELVES FOR 60IN LONG UNITS			
COLOR	BRACKET (NEED TWO)	SUPPORT	SHELF
BLACK	67-21387-1B	M21488-3B	M21487-13B
WHITE	67-21387-1W	M21488-3W	M21487-13W
STAINLESS	67-21387-1S	M21488-3S	M21487-13S
SHELF PARTS FOR 78IN, TOP 2-3 15IN DEEP SHELVES FOR 72IN LONG UNITS			
COLOR	BRACKET (NEED TWO)	SUPPORT	SHELF
BLACK	67-21387-1B	M21488-4B	M21487-14B
WHITE	67-21387-1W	M21488-4W	M21487-14W
STAINLESS	67-21387-1S	M21488-4S	M21487-14S
17IN DEEP SHELVES FOR BOTTOM TWO SHELVES OF 78IN TALL OR ANY 60IN TALL, 36IN LONG			
COLOR	BRACKET (NEED TWO)	SUPPORT	SHELF
BLACK	67-21387-B	M21488-1B	M21487-1B
WHITE	67-21387-W	M21488-1W	M21487-1W
STAINLESS	67-21387-S	M21488-1S	M21487-1S
17IN DEEP SHELVES FOR BOTTOM TWO SHELVES OF 78IN TALL OR ANY 60IN TALL, 48IN LONG			
COLOR	BRACKET (NEED TWO)	SUPPORT	SHELF
BLACK	67-21387-B	M21488-2B	M21487-2B
WHITE	67-21387-W	M21488-2W	M21487-2W
STAINLESS	67-21387-S	M21488-2S	M21487-2S
17IN DEEP SHELVES FOR BOTTOM TWO SHELVES OF 78IN TALL OR ANY 60IN TALL, 60IN LONG			
COLOR	BRACKET (NEED TWO)	SUPPORT	SHELF
BLACK	67-21387-B	M21488-3B	M21487-3B
WHITE	67-21387-W	M21488-3W	M21487-3W
STAINLESS	67-21387-S	M21488-3S	M21487-3S
17IN DEEP SHELVES FOR BOTTOM TWO SHELVES OF 78IN TALL OR ANY 60IN TALL, 72IN LONG			
COLOR	BRACKET (NEED TWO)	SUPPORT	SHELF
BLACK	67-21387-B	M21488-4B	M21487-4B
WHITE	67-21387-W	M21488-4W	M21487-4W
STAINLESS	67-21387-S	M21488-4S	M21487-4S

LEGS AND CASTERS		
Description	PART#	QTY/CASE
LEG LEVELER ASSEMBLY	SA4368-1	4
LEG LEVELER	65-21273	4
HOUSING	SA4295	4
6" LEG ASSEMBLY	SA4368-2	4
6" LEG	65-12886	4
SCREW, 1/4-20	75-10948	16
HOUSING	SA4295	4
4" CASTER ASSEMBLY	SA4368-3	4
4" CASTER	65-10675	4
SCREW, 1/4-20	75-10948	16
HOUSING	SA4295	4
RECESSED CASTER ASSEMBLY	SA4368-4	4
2.5" CASTER	65-17352	4
SCREW, 1/4-20	75-10948	16
HOUSING	M15895-2	4
6" SEISMIC LEG ASSEMBLY	SA4368-13	4
6" SEISMIC LEG	65-19069	4
SCREW, 1/4-20	75-10948	16
HOUSING	SA4295	4
SLIDE -IN ADJUSTABLE CASTER ASSEMBLIES		4
ADJUSTABLE CASTERS SLIDE-IN	65-21657	4
SCREW, 1/4-20	75-10948	64
INNER SLIDE HOUSING	M21799	4
OUTER SLIDE HOUSING	M21798	4
BRACE SLIDE HOUSING	M21814	2

Kits	
LED Shelf Lights	Kit#
VRSS 3660	800-9200-LEDK
VRSS3678	801-9200-LEDK
VRSS4860	802-9200-LEDK
VRSS4878	803-9200-LEDK
VRSS6060	804-9200-LEDK
VRSS6078	805-9200-LEDK
VRSS7260	806-9200-LEDK
VRSS7278	807-9200-LEDK
High Output Condensate Pan, Single Drain Units	Kit#
VRSS3660	800-9121-PANK
VRSS3678	800-9121-PANK
VRSS4860	802-9121-PANK
VRSS4878	802-9121-PANK
VRSS6060	802-9121-PANK
VRSS6078	802-9121-PANK
VRSS7260	802-9121-PANK
VRSS7278	802-9121-PANK
High Output Condensate Pan, Dual Drain Units	
VRSS6060	804-9122-PANK
VRSS6078	804-9122-PANK
VRSS7260	806-9122-PANK
VRSS7278	806-9122-PANK

REV	CHANGE RECORD	APP'D	DATE	ECN#
-	INITIAL RELEASE	JTR	11/12/21	
A	Added security cover, and additional wiring diagrams	JTR	11/23/21	
B	Added quick start guide	JTR	12/8/21	
C	Separated quick start guide from manual	JTR	12/21/21	
D	Updated service parts	JTR	6/1/22	3804
E	Updated service parts	JTR	7/5/22	3800
F	Added kits	JTR	8/4/2022	3807
G	Added Part #'s for air deflectors for roll covers	BJW	12/02/22	3839
H	Added high output condo pan kit to kit list for VRSS36	ADC	2/14/2023	3847
I	Updated Remote Wiring Diagram	BJW	4/19/23	
J	Added Refrigerated Slide-in Information	BJW	6/22/23	3855
K	Corrected Shelf Bracket Numbers For The 17" Shelves	BJW	7/10/23	
L	Added Alcove Installation Section	LPR	7/18/23	3869

California Residents Only.

⚠ WARNING

This product can expose you to chemicals including chromium which is known to the State of California to cause cancer and birth defects or other reproductive harm. For more information go to

www.P65Warnings.ca.gov