



Job: \_\_\_\_\_ Item# \_\_\_\_\_



EC-10,12TW-SD30

# EC-(10,12) TW WITH SD-30 STAND

- EC-10 TW with SD-30 Stand
- EC-12 TW with SD-30 Stand



### STANDARD CONSTRUCTION SPECIFICATIONS

Crown Model EC-(10,12)TW self generating electric kettle , with optional SD-30 stand, open type equipment stand with sliding drawer.

All stainless steel construction 1 ¼” square tubular frame with four (4) adjustable flanged feet for floor anchoring. , and a removable drain drawer with roller action slides, high front splash shield, removable splash diffusing drawer bottom for added splash control and stationary drain connection.



Approval Notes: \_\_\_\_\_  
\_\_\_\_\_  
\_\_\_\_\_

DIMENSIONS ARE IN INCHES [MM]

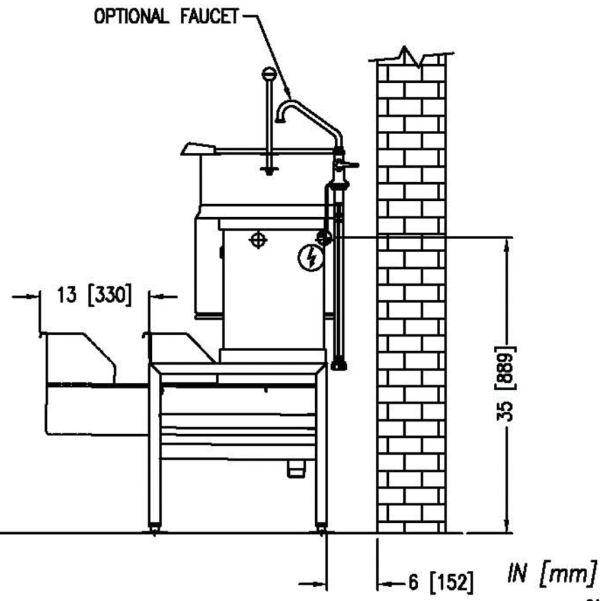
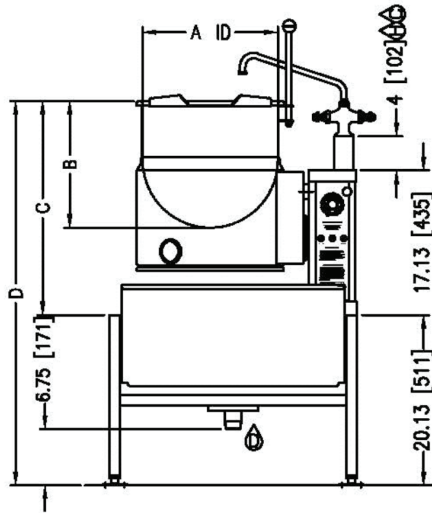
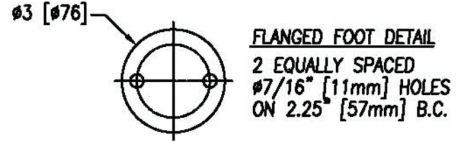
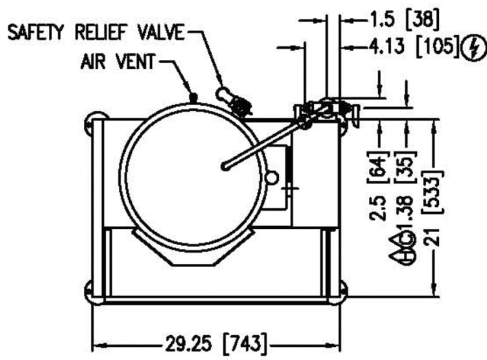

8481R1

**SERVICE CONNECTIONS**

- ⚡ – ELECTRICAL CONNECTION to be as specified on data plate
- Ⓒ – COLD WATER: Compression fittings for 5/8" O.D. copper tubing or 1/2 NPSM Male
- Ⓓ – HOT WATER: Compression fittings for 5/8" O.D. copper tubing or 1/2 NPSM Male
- Ⓔ – DRAIN: 1-1/2" -11-1/2" NPT

**DIMENSIONS**

MODEL	CAPACITY	UNITS	A	B	C	D	SHIPPING WEIGHT WITH STAND	MINIMUM CLEARANCE		
								R.H. SIDES	L.H. SIDES	BACK
EC-10TW	10 Gallons (38 liters)	INCHES (MM)	16" (406)	15" (381)	25.31" (643)	45.5" (1156)	225 lbs. (102 kg)	0	3 (76)	2 (51)
EC-12TW	12 Gallons (45 liters)	INCHES (MM)		17" (432)	27.31" (694)	47.5" (1207)				

**INTENDED FOR COMMERCIAL USE ONLY.  
NOT FOR HOUSEHOLD USE.**

