



<b>IMPORTANT FOR FUTURE REFERENCE</b> Please complete this information and retain this manual for the life of the equipment:
Model #: _____
Serial #: _____
Date Purchased: _____

## Installation & Operation Manual

# Electric Floor Model Braising Pan with Manual Gearbox Tilt ES-30 & ES-40



Model ES-40

### **WARNING**

Improper installation, adjustment, alteration, service or maintenance can cause property damage, injury or death. Read the installation, operating and maintenance instructions thoroughly before installing or servicing this equipment.

### **CROWN FOOD SERVICE EQUIPMENT**

 **MIDDLEBY** A Middleby Company

70 Oakdale Road, Downsview (Toronto) Ontario, Canada, M3N 1V9

Telephone: 919-762-1000

[www.crownsteamgroup.com](http://www.crownsteamgroup.com)

# SAFETY PRECAUTIONS

Before installing and operating this equipment, be sure everyone involved in its operation is fully trained and aware of precautions. Accidents and problems can be caused by failure to follow fundamental rules and precautions.

The following symbols, found throughout this manual, alert you to potentially dangerous conditions to the operator, service personnel, or to the equipment.



This symbol warns of immediate hazards that will result in severe injury or death.



This symbol refers to a potential hazard or unsafe practice that could result in injury or death.



This symbol refers to a potential hazard or unsafe practice that could result in injury, product damage, or property damage.



This symbol refers to information that needs special attention or must be fully understood, even though not dangerous.

## IMPORTANT NOTES FOR INSTALLATION AND OPERATION

### **WARNING**

This is the safety alert symbol. It is used to alert you to potential personal injury hazards. Obey all safety messages that follow this symbol to avoid possible injury or death.

### **WARNING**

**FOR YOUR SAFETY:**

Do not store or use gasoline or other flammable vapors or liquids in the vicinity of this or any other appliance.

### **WARNING**

Improper installation, operation, adjustment, alteration, service or maintenance can cause property damage, injury or death. Read the installation, operating and maintenance instructions thoroughly before installing, operating or servicing this equipment.

### **NOTICE**

This product is intended for commercial use only. NOT FOR HOUSEHOLD USE.

### **NOTICE**

This manual should be retained for future reference.

Keep the appliance area free and clear from combustibles.

Adequate clearances **MUST** be maintained for servicing and proper operation.

Contact the factory, the factory representative or a local service company to perform maintenance and repairs should the appliance malfunction. Refer to warranty terms.

RETAIN THIS MANUAL FOR FUTURE REFERENCE.

## Table of Contents

Important Notes For Installation and Operation .....	2
Service Connections .....	4
Installation Instructions .....	6
Operation .....	8
Maintenance .....	10
Cooking Guidelines.....	11
Troubleshooting .....	14

# SERVICE CONNECTIONS

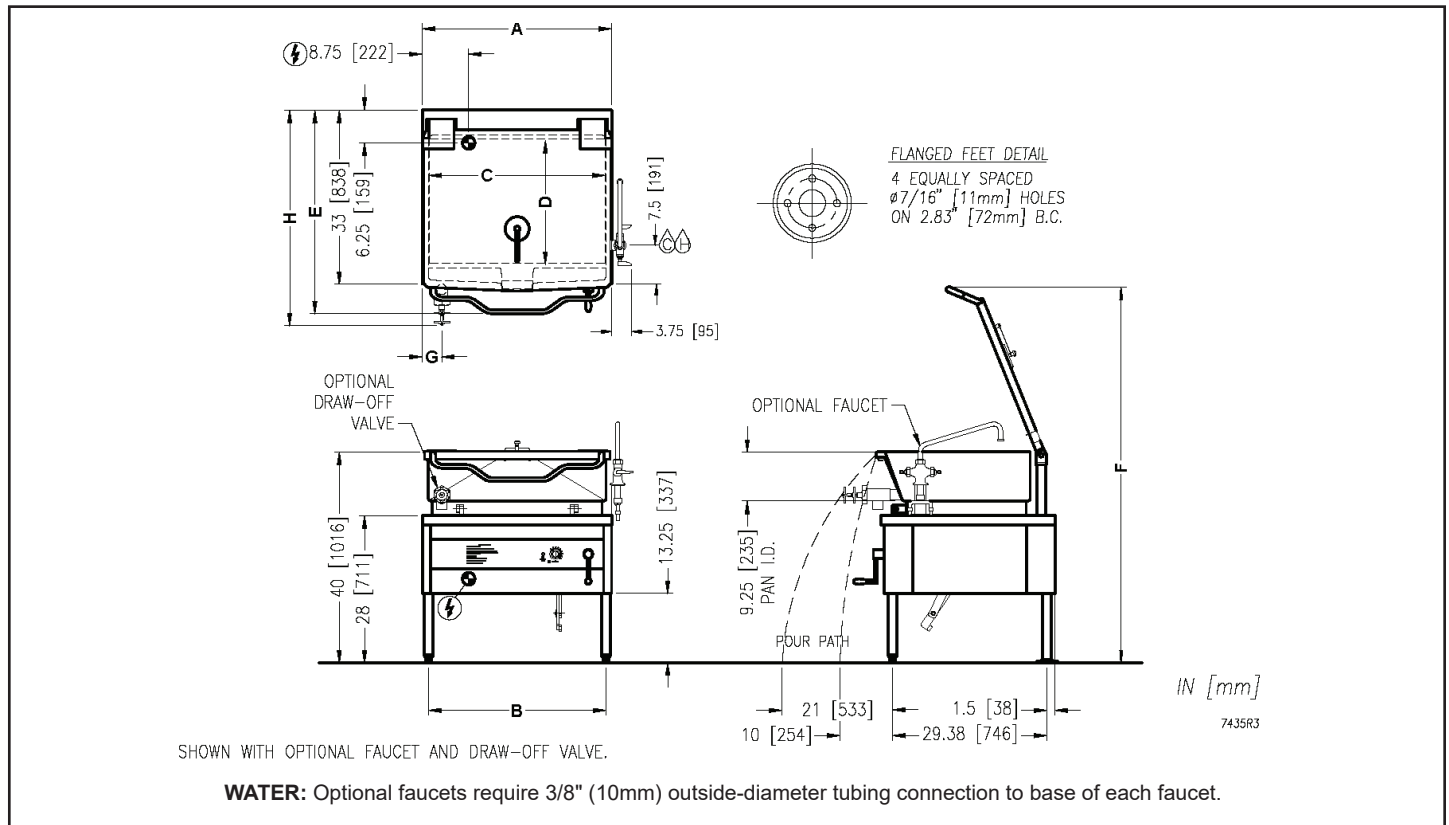

### SERVICE CONNECTIONS

⚡ – ELECTRICAL CONNECTION to be as specified on data plate.      ⚡ – HOT WATER: 3/8" O.D. tubing to optional faucet  
 Ⓢ – COLD WATER: 3/8" O.D. tubing to optional faucet

### DIMENSIONS

MODEL	SHIPPING WEIGHT	CAPACITY	A	B	C	D	E	F	G	H	
										Ø2	Ø3
ES-30	545 lbs. [247 kg]	30 Gallons (114 liters)	36" (914)	33.63" (854)	33.5" (851)	23.5" (597)	38.88" (987)	71.38" (1813)	3.75" (95)	41.13" (1045 mm)	46.75" (1187 mm)
ES-40	710 lbs. [322 kg]	40 Gallons (152 liters)	48" (1219)	45.63" (1159)	43.5" (1105)	23" (584)	39.38" (1000)	70.88" (1800)	4.75" (121)	41.63" (1057 mm)	46.13" (1172 mm)

### ELECTRICAL CHARACTERISTIC

MODEL	kW	PHASE	AMPS PER LINE							MINIMUM CLEARANCE	
			208V	220V	240V	380V	415V	480V	600V		
ES-30	12	1	57.7 A	54.5 A	50.0 A	N/A	N/A	N/A	N/A	Sides	0
		3	33.3 A	31.5 A	28.9 A	18.2 A	16.7 A	14.4 A	11.5 A		
ES-40	18	1	86.5 A	81.8 A	75.0 A	N/A	N/A	N/A	N/A	Back	0
		3	50.0 A	47.2 A	43.3 A	27.3 A	25.0 A	21.7 A	17.3 A		

As continued product improvement is a policy of Crown, specifications are subject to change without notice.

WITH OPTIONAL S-SDP-2 ASSEMBLY

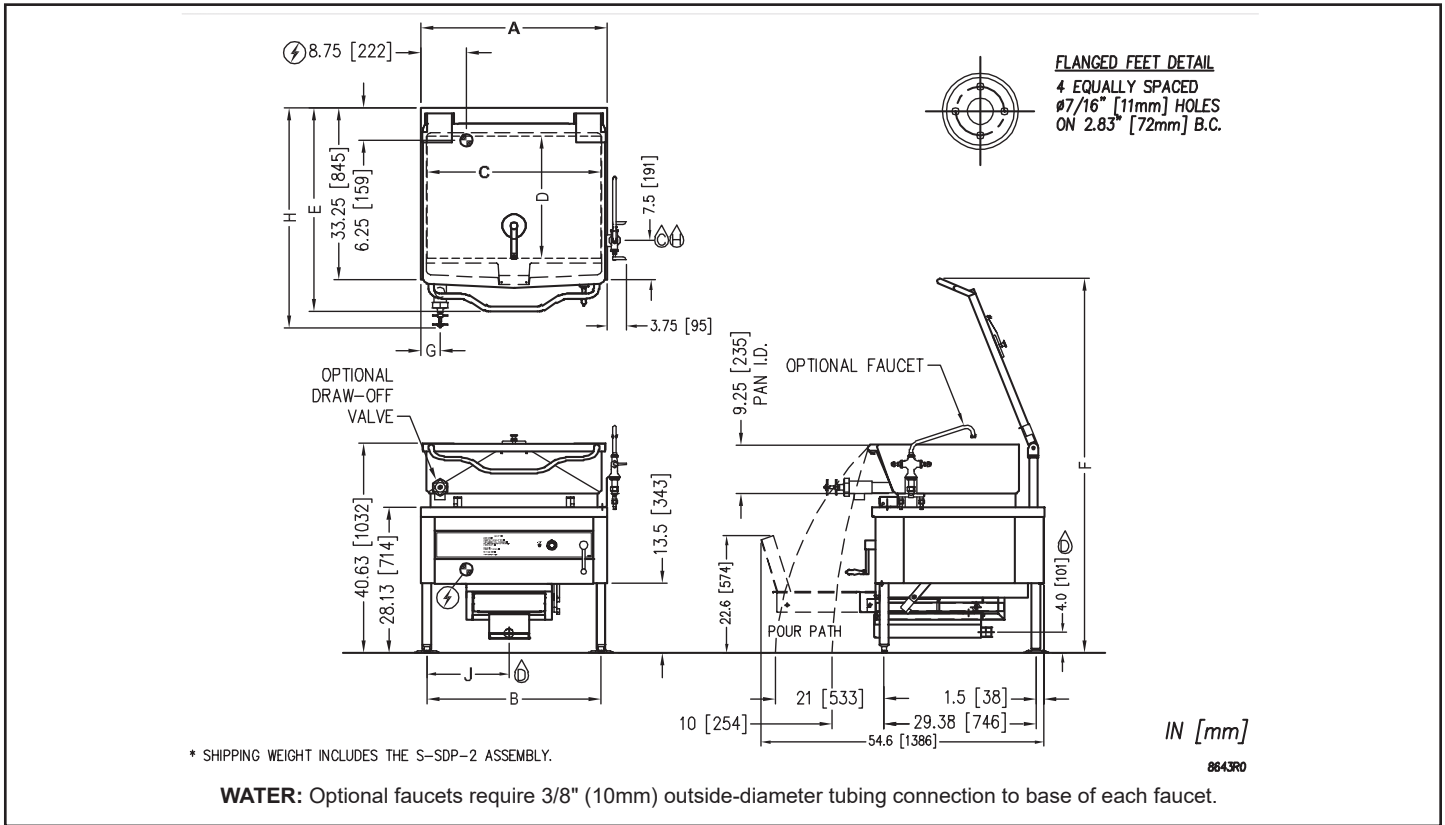

**SERVICE CONNECTIONS**

⚡ – ELECTRICAL CONNECTION to be as specified on data plate.

⦿ – HOT WATER: 3/8" O.D. tubing to optional faucet

Ⓢ – COLD WATER: 3/8" O.D. tubing to optional faucet

Ⓣ – DRAIN: 1 1/2 – 11 1/2" NPT (Optional)

**DIMENSIONS**

MODEL	SHIPPING WEIGHT	CAPACITY	A	B	C	D	E	F	G	H		J
										Ø2	Ø3	
ES-30	585 lbs. [247 kg]	30 Gallons (114 liters)	36" (914)	33.63" (854)	33.5" (851)	23.5" (597)	39.5" (1003)	72.38" (1838)	3.75" (95)	42.83" (1083 mm)	46.5" (1181 mm)	15.9" (404 mm)
ES-40	750 lbs. [322 kg]	40 Gallons (152 liters)	48" (1219)	45.63" (1159)	43.5" (1105)	23" (584)	39.88" (1013)	71.88" (1826)	4.75" (121)	42.63" (1083 mm)	46.5" (1181 mm)	22.8" (580 mm)

**ELECTRICAL CHARACTERISTIC**

MODEL	kW	PHASE	AMPS PER LINE							MINIMUM CLEARANCE	
			208V	220V	240V	380V	415V	480V	600V	Sides	Back
ES-30	12	1	57.7 A	54.5 A	50.0 A	N/A	N/A	N/A	N/A	Sides	0
		3	33.3 A	31.5 A	28.9 A	18.2 A	16.7 A	14.4 A	11.5 A		
ES-40	18	1	86.5 A	81.8 A	75.0 A	N/A	N/A	N/A	N/A	Back	0
		3	50.0 A	47.2 A	43.3 A	27.3 A	25.0 A	21.7 A	17.3 A		

# INSTALLATION INSTRUCTIONS

## UNPACKING

### IMMEDIATELY INSPECT FOR SHIPPING DAMAGE

Immediately after unpacking, check for possible shipping damage. If the tilting braising pan is found to be damaged, save the packaging material and contact the carrier within 15 days of delivery.

Before installing, verify that the electrical service agrees with the specifications on the rating plate located on the left side panel as you face the front of the braising pan. If the supply and equipment requirements do not agree, contact your dealer or Crown Food Service Equipment Ltd.

## LOCATION

The installation location must allow adequate clearances for servicing and proper operation. A minimum front clearance of 36", and rear clearance of 6" is required.

## INSTALLATION CODES AND STANDARDS

Your Crown Tilting Braising Pan must be installed in accordance with:

1. In the U.S.A. installation must comply with state and local codes, or in the absence of local codes, with the National Electrical Code ANSI/NFPA-70 (latest edition). In Canada installation must comply with Provincial and local codes, or in the absence of local codes, with: C.S.A. C22.1 Canadian Electrical Code, Part 1.
2. ANSI NFPA Standard #96, "Vapor Removal from Cooking Equipment," (latest edition), available from the National Fire Protection Association, Batterymarch Park, Quincy, MA, U.S.A. 02269.

## LEVELING AND ANCHORING TILTING BRAISING PAN

1. Place tilting braising pan in the installation position.
2. Place a carpenter's level on top of the braising pan and turn the adjustable feet to level braising pan side-to-side and front-to-back.
3. Mark hole locations on the floor through the anchoring holes provided in the rear flanged adjustable feet.
4. Remove tilting braising pan from installation position and drill holes in locations marked on the floor. (See Service Connections Section in this manual.) Insert proper anchoring devices (not supplied).
5. Place tilting braising pan back in the installation position.
6. Place carpenter's level on top of braising pan and re-level side-to-side and front-to-back.
7. Bolt and anchor tilting braising pan securely to the floor.
8. Seal bolts and flanged feet with silastic or equivalent compound.

## ELECTRICAL CONNECTIONS

 **WARNING**

**ELECTRICAL GROUNDING INSTRUCTIONS**

Electrical and grounding connections must comply with the applicable portions of the National Electrical Code and/or other local codes.

 **WARNING**

Before performing any maintenance disconnect the electrical power supply and place a tag at the disconnect switch to indicate that you are working on the circuit.

The wiring compartment is located behind the control panel. Refer to Page 4 Service Connections.

1. Remove the wiring compartment cover and make electrical connections per the wiring diagram located inside the control housing cover panel. (The braising pan must be grounded in accordance with requirements of the National Electrical Code or applicable local codes.) (See Electrical Grounding Warning above). Connection from incoming lines must be waterproof.
2. To access the wiring compartment: remove the tilt handle, loosen hinge screws (about 1/2") at the bottom of compartment and pull down the front control panel.
3. Ground skillet to terminal provided in control housing. A wiring diagram is provided and is located inside the control cover panel.
4. Replace wiring compartment cover.

## SERVICE CONNECTIONS

All internal wiring for the skillet is complete.

Make service connections as indicated. (See Service Connections and Installation Instructions Sections in this manual.)

If a faucet is provided, connect the water supplies and check for proper operation.

# OPERATION

## WARNING

The tilting braising pan and its parts are hot. Use care when operating, cleaning and servicing the tilting braising pan.

## BEFORE FIRST USE

Using a non-corrosive, grease-dissolving commercial cleaner, clean the protective metal oils from all surface parts and the interior of the tilting braising pan. Follow the cleaner manufacturer's directions. Rinse thoroughly and drain the pan. Wipe dry with a soft clean cloth.

## CONTROLS (FIGURE 1)

**Red Temperature Light** ..... Illuminates when heating elements are supplying heat to the tilting braising pan.

**Thermostat** ..... Turns tilting braising pan ON and maintains set temperature by controlling power supply. Temperature settings are marked on the control panel in either °C or °F.

**Tilt Handle** ..... Used to manually raise and lower braising pan.

Figure 1

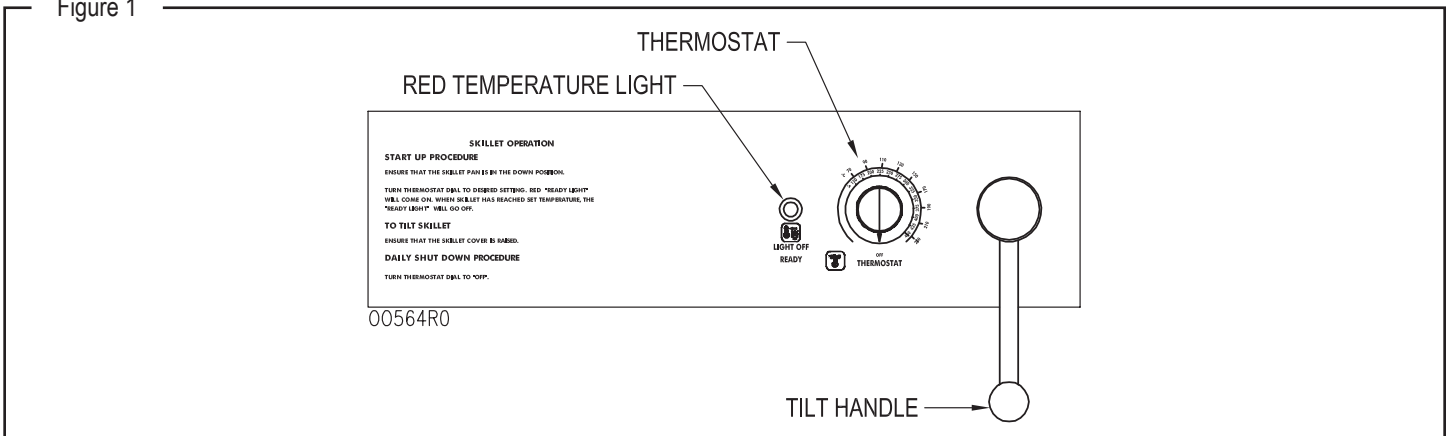

## START-UP PROCEDURE

1. Ensure that the braising pan is in the DOWN position.
2. Turn THERMOSTAT dial to desired temperature (reference Cooking Guidelines in this manual). The red TEMPERATURE light will come on.
3. When braising pan has reached set temperature, the red TEMPERATURE light will go off and the heating elements will shut off. The heating elements will cycle on and off thereafter to maintain set temperature. The red TEMPERATURE light will cycle on and off with the heating elements.
4. Preheat braising pan and allow it to cycle to equalize heat across the entire surface.
5. Water will boil faster with the lid down.
6. Turn THERMOSTAT to OFF when braising pan is not in use.

## DAILY SHUTDOWN PROCEDURE

Turn THERMOSTAT dial to OFF.



## TILTING THE BRAISING PAN

1. DO NOT try to tilt braising pan with lid down.
2. Make sure the receiving pan is in place.
3. Turn crank handle clockwise to lift the braising pan and counterclockwise to lower the braising pan. When the braising pan is raised 5° or more, the electrical supply will be turned off automatically. The braising pan will not operate once the pan has been tilted.
4. Food is poured through the removable strainer (Figure 2) into a food receiving pan positioned under the lip of the pouring spout.

Figure 2

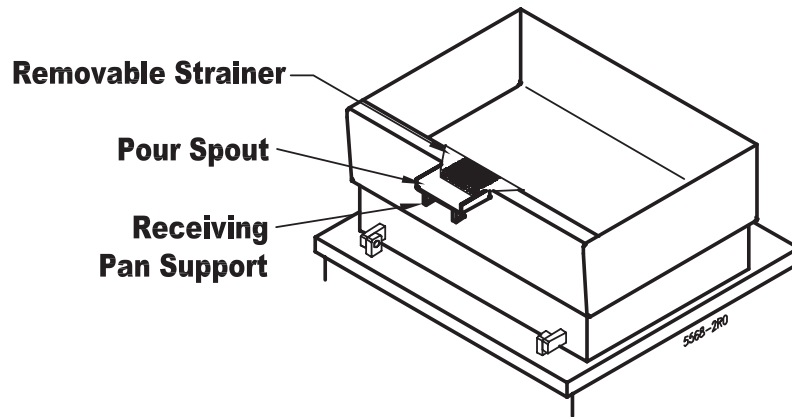

# MAINTENANCE

 **WARNING**

Disconnect the power supply to the appliance before cleaning or servicing.

## CLEANING INSTRUCTIONS

Before cleaning allow the tilting braising pan to cool and then clean it. Keep exposed cleanable areas of the tilting braising pan clean at all times. Do not get water in electrical box or any electrical component.

1. Thoroughly wash pan, pouring spout (see Figure 2), lid and exterior surfaces with detergent and warm water. If necessary, soak pan to remove food that is stuck to pan surface. Rinse thoroughly and wipe dry with a soft clean cloth.
2. Clean removable strainer and receiving pan support (Figure 2) with detergent and warm water. Rinse thoroughly and wipe dry with a soft clean cloth.

## ADJUSTMENTS

All tilting braising pans are adjusted at the factory.

At least twice a year, have an authorized service person clean and adjust the tilting braising pan for maximum performance.

# COOKING GUIDELINES

The guidelines given below are suggested quantities, temperature settings, and estimated numbers of orders per load and per hour. When two temperatures are given, the first is to start the product, and the second to finish the product.

The following temperatures should be used:

COOKING METHOD	TEMPERATURE (°F)
Simmering	200 Maximum
Sautéing	225 - 275
Searing	300 - 350
Frying	325 - 375
Grilling	350 - 450

ITEM	PORTION SIZE	TEMP.(EF)	BATCHES PER HOUR	ES-30 PER LOAD		ES-40 PER LOAD	
				QTY.	PORTIONS	QTY.	PORTIONS
<b>BREAKFAST FOODS</b>							
Bacon	3 slices	350	12	2 lb	10	3 lb	15
Eggs							
- Boiled - Hard	1 egg	225	5	50 eggs	50	75 eggs	75
- Boiled-Soft	1 egg	225	8	50 eggs	50	75 eggs	75
- Fried	1 egg	400	4	30 eggs	30	45 eggs	45
- Poached	1 egg	225	5	36 eggs	36	60 eggs	60
- Scrambled	1-1/2 eggs	300-200	1	18 gal.	720	28 gal.	1100
French Toast	3 slices	450	7	35 slices	12	50 slices	17
Regular Oatmeal	1/2 cup	250	2	20 lb (100 cups)	500	40 lb (200 cups)	1000
Pancakes	2 each	400	10	30 each	15	50 each	25
<b>FISH</b>							
Clams	1 pint	400	10	10 quarts	20	15 quarts	30
Fish Cakes	2 - 3 oz	400	5	70 - 3 oz	35	110 - 3 oz	55
Haddock Fillet	4 oz	400	4	60 - 4 oz	60	90 - 4 oz	90
Halibut Steak	5 oz	450	3	60 - 4 oz	60	90 - 4 oz	90
Lobster	1 - 1 lb	350	4	20 - 1 lb	20	30 - 1 lb	30
Swordfish	5 oz	450	3	50 - 5 oz	50	75 - 5 oz	75
<b>SAUCES, GRAVIES, SOUPS</b>							
Brown Gravy	1 oz	350 - 200	2	18 gal.	2300	35 gal.	4500
Cream Sauce	2 oz	250 - 175	1	18 gal.	1150	35 gal.	2250
Cream Soup	6 oz	200	1	18 gal.	375	35 gal.	725
French OnionSoup	6 oz	225	1	18 gal.	350	35 gal.	700
Meat Sauce	4 oz	350 - 200	1	18 gal.	575	35 gal.	1100
<b>VEGETABLES</b>							
<b>CANNED</b>	3 oz	400	6	30 lb	125	45 lb	200
<b>FRESH</b>							
Beans, Wax,Green	3 oz	400	3	25 lb	125	50 lb	250
Beets	3 oz	400	1	30 lb	125	60 lb	300

ITEM	PORTION SIZE	TEMP.(EF)	BATCHES PER HOUR	ES-30 PER LOAD		ES-40 PER LOAD	
				QTY.	PORTIONS	QTY.	PORTIONS
<b>VEGETABLES (continued)</b>							
<b>FRESH (continued)</b>							
Broccoli	3 oz	400	3	25 lb	125	40 lb	200
Cabbage	3 oz	400	5	20 lb	80	30 lb	125
Carrots	3 oz	400	2	35 lb	150	70 lb	300
Cauliflower	3 oz	250	5	15 lb	75	25 lb	125
Corn	1 ear	400	8	50 ears	50	75 ears	75
Potatoes	3 oz	400	2	40 lb	200	60 lb	300
Spinach	4 oz	250	10	40 lb	200	9 lb	35
Turnips	4 oz	400	2	20 lb	100	30 lb	150
<b>FROZEN</b>							
Beans, FrenchGreen	3 oz	400	6	15 lb	60	22-1/2 lb	90
Lima Beans	3 oz	250	4	15 lb	60	22-1/2 lb	90
Broccoli	3 oz	400	8	12 lb	50	18 lb	75
Sliced Carrots	3 oz	250	6	15 lb	60	22-1/2 lb	90
Small WholeCarrots	3 oz	250	3	15 lb	50	22-1/2 lb	90
Corn	3 oz	250	18	15 lb	50	22-1/2 lb	90
Small WholeOnions	3 oz	250	7	15 lb	50	22-1/2 lb	90
Peas	3 oz	400	10	15 lb	75	22-1/2 lb	110
Spinach	3 oz	400	3	15 lb	75	22-1/2 lb	110
<b>DESSERTS, PUDDINGS, SWEET SAUCES</b>							
ButterscotchSauce	1 oz	200	1	18 gal.	2300	35 gal.	4500
Cherry Cobbler	3 oz	200	1	18 gal.	750	35 gal.	1500
Chocolate Sauce	1 oz	200	1	18 gal.	2300	35 gal.	4500
CornstarchPudding	4 oz	200	1	18 gal.	575	35 gal.	1100
Fruit Gelatin	3 oz	250	2	18 gal.	750	35 gal.	1500
<b>MEAT-POULTRY</b>							
<b>BEEF</b>							
American ChopSuey	6 oz	400 - 225	2	18 gal.	350	35 gal.	700
Beef Stew	8 oz	300	-	18 gal.	280	35 gal.	560
Comed BeefHash	5 oz	400	5	16 lb	50	25 lb	75
Cheeseburger	3 oz	300	12	7 lb	35	10 lb	50
Hamburger	3 oz	300	15	7 lb	35	10 lb	50
Meatballs	1 oz	400 - 225	3	12-1/2 lb	65	18 lb	100
Pot Roast	2 oz	350 - 200		120 lb	500	180 lb	750
Salisbury Steak	5 oz	400	3	16 lb	50	24 lb	75
Sirloin Steak	6 oz	400	5	15 lb	40	22-1/2 lb	60
Swiss Steak	4 oz	300 - 200	1	25 lb	110	40 lb	160
<b>CHICKEN</b>							
Pan Fried	2-1/4's	350	3	50 pieces	25	80 pieces	40
Whole	2 oz	350 - 200		16 - 5 lb	200	24-5 lb	265

ITEM	PORTION SIZE	TEMP.(EF)	BATCHES PER HOUR	ES-30 PER LOAD		ES-40 PER LOAD	
				QTY.	PORTIONS	QTY.	PORTIONS
<b>MEAT-POULTRY (continued)</b>							
<b>FRANKFURTERS</b>							
Grilled	2 oz	300	8	22 lb	176	33 lb	264
Boiled	2 oz	250	12	16 lb	128	25 lb	200
<b>PORK</b>							
Bacon	3 slices	350	12	2 lb	10	3 lb	15
Ham Steak	3 oz	400	8	10 lb	50	15 lb	75
Pork Chops	5 oz	350	4	15 lb	50	25 lb	75
Sausage Links	3 links	350	7	30 lb	120	45 lb	180
<b>TURKEY</b>							
Off Carcass	2 oz	400 - 200	–	3 - 26-30 lb	200	4 - 26-30 lb	275
On Carcass	2 oz	400 - 200	–	4 - 16-20 lb	175	6 - 16-20 lb	265
<b>MISCELLANEOUS</b>							
Grilled Cheese Sandwich	1 sandwich	400	8	35 sandwiches	35	50 sandwiches	50
Macaroni & Cheese	8 oz	200	2	18 gal.	300	35 gal.	525
Rice	4 oz	350 - 225	1	20 lb raw	320	40 lb raw	650
Spaghetti	4 oz	350 - 225	2	8 lb raw	200	12 lb raw	300

# TROUBLESHOOTING

## HEATING ELEMENTS NO NOT COME ON

1. Power supply not "ON".
2. Pan not in down position.
3. Defective thermostat or elements.
4. Defective limit switch or activator mechanism.
5. Defective contactors.

NOTES

# ES-30 & ES-40

## Electric Floor Model Braising Pan with Manual Gearbox Tilt



A product with the Crown name incorporates the best in durability and low maintenance. We all recognize, however, that replacement parts and occasional professional service may be necessary to extend the useful life of this appliance. When service is needed, contact a Crown Authorized Service Agency, or your dealer. To avoid confusion, always refer to the model number, serial number, and type of your appliance.



### CROWN FOOD SERVICE EQUIPMENT

 **MIDDLEBY** A Middleby Company

70 Oakdale Road, Downsview (Toronto) Ontario, Canada, M3N 1V9  
Telephone: 919-762-1000      [www.crownsteamgroup.com](http://www.crownsteamgroup.com)