



THE TIME & TEMPERATURE COMPANY®

Model: TCT572

## ProAccurate® Folding Thermocouple Thermometer

-58 to +572°F/-50 to +300°C

### Perfect For

- Thin cuts of meat, fish or poultry

### Easy To Use

- 3-6 second response
- Backlit in blue
- Extra big digit
- Temperature guide

### Features

- NSF® Certified
- 1.5 mm thin tip
- 4.25"/10.8 cm stainless steel probe
- Water resistant
- Shatterproof
- Maximum & minimum
- Food-safe ABS plastic with BioCote®
- Field calibration
- On/off button
- Auto-off after 10 minutes
- Mounting: loop
- Batteries & instructions included

### Get Professional Results Every Time!

Perfect for thin cuts of meat, fish or poultry. Simply flip down the rapid-response thermocouple probe and insert it into food as thin as 1/8-inch. BioCote® technology gives the water resistant housing constant, built-in antimicrobial protection, providing a finish that helps prevent microbes from growing on the surface. The display features extra big digits and can be backlit for low light conditions.

The TCT572 offers Minimum and Maximum modes. Minimum mode displays the lowest temperature among multiple readings. Maximum mode displays the highest temperature among multiple readings.

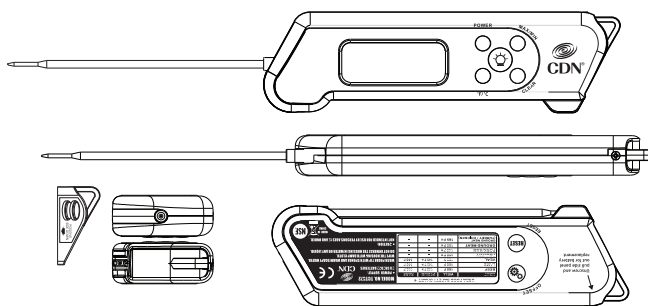

**Note:** Remove sticker from display before use.

Pro  
Accurate® NSF BioCote  
Quick-Read®

**Note:** In the following instructions, names of the control buttons are shown in CAPS. Function information that appears on the display is shown in **BOLD CAPS**.

## Battery Installation

The thermometer beeps when the battery needs to be replaced.

1. Power off the unit before installing the battery.  
A malfunction may occur if the power is on when the battery is installed. If a malfunction occurs, press the RESET button on the back or restart the device.
2. Using a small Phillips screwdriver, remove the screw on the top by turning it counter clockwise.
3. Pull side panel completely out.
4. Install two CR2032 batteries observing polarity shown in compartment.
5. Replace the battery cover.  
**Important: THE WATER RESISTANT FEATURE REQUIRES MAINTAINING THE RUBBER GASKET EVENLY WITHIN THE GROOVE.**
6. Fasten the screw on the top by turning it clockwise, being careful not to over-turn.

## Operating Instructions

### A. On/Off

1. Press the POWER button to turn the thermometer on.
2. The TCT572 will automatically turn off after 10 minutes of inactivity.
3. Press the POWER button again to turn the thermometer off and conserve battery life.

### B. Temperature Scale

To select temperature reading in Fahrenheit or Celsius:

1. Press the °F/°C button to change the scale. The °F or °C symbol changes on the display and a beep sounds.

### C. LCD Backlight Thermometer

1. Press the LIGHT button to turn the backlight on
2. The backlight will stay on for 5 seconds.

### D. Temperature Measurement

**Important: THE PROBE MAY BE DAMAGED IF MEASUREMENT TEMPERATURE IS LOWER THAN -58°F/-50°C OR HIGHER THAN +572°F/+300°C.**

**Note:** The TCT572 is intended for food service use — do not use for safety related applications.

1. Flip down the probe until fully extended.
2. Insert the probe at least 0.25"/6.3 mm into the food.
3. The current cooking temperature appears on the display.

4. Wearing a heat resistant glove, flip the probe back into the case when finished.

**Important: DO NOT TWIST THE PROBE OR ROTATE IT IN WRONG DIRECTION. EXCEPTIONAL STRESS ON PROBE MAY CAUSE IT TO BREAK.**

**CAUTION:** Probe may be **HOT** after use. Always wear a heat resistant glove to touch the stainless steel probe or sensor cable during or just after cooking. **Do not touch with bare hands.**

### E. Maximum Mode

1. Press the MAX/MIN button once. **MAX** appears on the display along with the last highest/maximum temperature.
2. To clear the MAX/MIN reading, Press the MAX/MIN button once, then press the CLEAR button. “---” appears on the display.

### F. Minimum Mode

1. Press the MAX/MIN button twice. **MIN** appears on the display along with the last lowest/minimum temperature.
2. To clear the MAX/MIN reading, Press the MAX/MIN button twice, then press the CLEAR button. “---” appears on the display.

### G. Recalibration

1. Place the stem into a mixture of 3 parts ice and 1 part water.
2. Press the OFFSET button for 2 seconds and until the beep sounds. The display will animate and display **0.0°F/°C**.
3. Press the OFFSET button repeatedly as needed to offset the factory calibration from -3.2 °F/-2.0 °C to +3.2 °F/+2.0 °C.

### H. Battery Status

1. When the voltage on the battery is low, **LO** flashes on the display along with the battery status icon.
2. The thermometer beeps when the battery needs to be replaced.

### I. Reset

1. Press the RESET button to reset the thermometer to factory defaults.

**Note:** Clean the thermometer probe before each use.

**Note for Induction Cooktops:** Sometimes, the induction cooktop magnetic field may interfere with digital thermometers. If there is interference, briefly turn off the induction cooktop to get a digital thermometer reading or use a dial thermometer.

**Important: DO NOT LEAVE THERMOMETER CASE IN HOT OVEN. CASE IS NOT HEAT RESISTANT. HAND WASH AND DRY. DO NOT IMMERSE HOUSING IN LIQUID.**

**Tip:** Meat should be allowed to “rest” for 10 to 15 minutes after it is removed from oven. This allows time for the meat’s internal temperature to stabilize and the juices to redistribute. This will result in a roast that is both juicier and easier to carve.

---

## Care of Your Product

---

- Do not submerge any part of the thermometer in water.
- Wipe clean with a damp cloth.
- Store the thermometer at room temperature between -4 to +149°F/-20 to +65°C..

## Specifications

---

<b>Operating Range:</b>	-58 to +572°F/-50 to +300°C
<b>Display Range:</b>	-58 to +572°F/-50 to +300°C
<b>Power:</b>	2 CR2032

## Precautions

---

- Dispose of used battery promptly and keep away from children.
  - Always wear a heat resistant glove to touch the stainless steel probe during or just after cooking.  
**Do not touch with bare hands.**
  - Keep the batteries, stainless steel probe and sensor cable away from children.
  - Clean the probe and dry thoroughly after use.
  - Do not clean the case with abrasive or corrosive compound, which may scratch the plastic and corrode the electronic circuits.
  - Do not subject the unit to excessive force shock, dust, temperature or humidity, which may result in malfunction, shorter electronic life span, damaged battery and distorted parts.
  - Do not tamper with the unit's internal components. Doing so will invalidate the warranty on the unit and may cause unnecessary battery damage and distorted parts.
  - Do not subject the unit to excessive exposure to direct sunlight. **The unit is not waterproof** – do not immerse it into water or expose to heavy rain.
  - To avoid deformation, do not place the unit in extreme temperatures. Never burn the probe directly over the fire. Do not use the probe when the temperature is above 572°F/300°C. Doing so will deteriorate the probe.
  - Do not use the thermometer in a microwave oven.
  - Always read the users manual thoroughly before operating.
-



**It's Safe to Bite When the Temperature's Right!™**

### USDA SAFE FOOD TEMPERATURES

- \* Beef, Veal, Lamb – well . . . . 160°F . . . 71°C
- \* Beef, Veal, Lamb – medium. 145°F . . 63°C
- \* Beef, Veal, Lamb – rare . . . . 140°F . . 60°C
- Poultry . . . . . 165°F . . . 74°C
- \* Pork/Ham – pre-cooked . . . 145°F . . 63°C
- Ground Meat. . . . . 160°F . . . 71°C
- \* 3 minutes rest time

### CANDY TEMPERATURE GUIDE

- Jelly . . . . . 220°F . . . . . 104°C
- Thread. . . . . 230–234°F . . . 110–112°C
- Soft Ball . . . . . 234–240°F . . . 112–115°C
- Firm Ball . . . . . 244–248°F . . . 118–120°C
- Hard Ball. . . . . 250–266°F . . . 121–130°C
- Soft Crack. . . . . 270–290°F . . . 132–143°C
- Hard Crack. . . . . 300–310°F . . . 149–154°C
- Caramelize . . . . . 316–338°F . . . 158–170°C

### HIGH ALTITUDE ADJUSTMENT FOR CANDY-MAKING

STAGE	2,000 feet	5,000 feet	7,500 feet
Soft Ball	230–236°F	224–230°F	219–225°F
Firm Ball	238–244°F	232–238°F	227–233°F
Hard Ball	246–264°F	240–258°F	235–253°F
Soft Crack	266–286°F	260–286°F	255–275°F
Hard Crack	296–306°F	290–300°F	285–295°F



Antimicrobial properties are built-in to inhibit the growth of bacteria that may affect this product. According to EPA guidelines we cannot claim that the antimicrobial properties in this product protect users or others against bacteria, viruses, germs, or other disease organisms. This product does not protect users or

others against food-borne bacteria. Always clean and wash this product thoroughly before and after each use.

The information in this document has been reviewed and is believed to be accurate. However, neither the manufacturer nor its affiliates assume any responsibility for inaccuracies, errors or omissions that may be contained herein. In no event will the manufacturer or its affiliates be liable for direct, indirect, special, incidental or consequential damages arisen by using this product or resulting from any defect/omission in this document, even if advised of the possibility of such damages. The manufacturer and its affiliates reserve the right to make improvements or changes to this document and the products and services described at any time, without notice or obligation.



**5-Year Limited Warranty:** Any instrument that proves to be defective in material or workmanship within five years of original purchase will be repaired or replaced without charge upon receipt of the unit prepaid at: CDN, PO Box 10947, Portland, OR 97296-0947. This warranty does not cover damage in shipment or failure caused by tampering, obvious carelessness or abuse.



For more detailed information on our products, please visit [cdn-timeandtemp.com](http://cdn-timeandtemp.com).



#### Component Design Northwest, Inc.

PO Box 10947  
Portland, OR 97296-0947

Tel 800 338-5594  
Fax 800 879-2364

[info@cdn-timeandtemp.com](mailto:info@cdn-timeandtemp.com)  
[www.cdn-timeandtemp.com](http://www.cdn-timeandtemp.com)

**CAUTION:** Avoid keeping the thermometer too close to objects that continuously generate high heat for long periods (i.e., hot plate). This can cause the thermometer to overheat.

**CE Note:** This device could be sensitive to electrostatic discharge. If electrostatic discharge or malfunctioning occurs, please re-install the battery to reset this unit.



\*USDA does not endorse any product, service or organization.