

WILBUR CURTIS COMPANY, INC.

Service Manual – Single and Dual Hopper Grinders

**FIND OUT MORE
ON THE WEB.**
WILBURCURTIS.COM

Models Included

- SHG
- DHG



CAUTION: Please use this setup procedure before attempting to use this grinder. Failure to follow the instructions can result in injury or the voiding of the warranty.



WARNING TO AVOID SCALDING, Do not remove brewcone while brew light is flashing.

Important Safeguards/Conventions

This appliance is designed for commercial use. Any servicing other than cleaning and maintenance should be performed by an authorized Wilbur Curtis service center.

- Do NOT immerse the unit in water or any other liquid
- To reduce the risk of fire or electric shock, do NOT open top panel. No user serviceable parts inside. Repair should be done only by authorized service personnel.
- Keep hands and other items away from hot parts of unit during operation.
- Never clean with scouring powders or harsh implements.

Conventions



WARNINGS – To help avoid personal injury



Important Notes/Cautions – from the factory

QUICK START & SETUP

SETUP

1. Install the grinder on a firm, level base in a location where it can be connected to a grounded electrical outlet of 120VAC, rated at 15 amps minimum.
2. Test the unit by running some whole bean coffee through the grinder. If any problems are encountered, refer to the troubleshooting section complete at www.wilburcurtis.com or call Technical Support at 800-995-0417.

OPERATING INSTRUCTIONS

1. Lift open the top cover of the grinder and fill with fresh whole bean coffee. Close the cover.
2. Place a new paper filter into the brewcone.

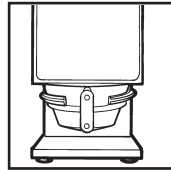

3. Insert the brewcone into the basket holder arms on the grinder.
4. Press the grind switch. The grinder will start to grind coffee. Allow the motor to come to a complete stop before removing the brewcone.
5. Transfer the filled brewcone to the brewer and press the desired brew button. The brew cycle is complete when the brew light stops flashing.

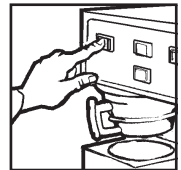
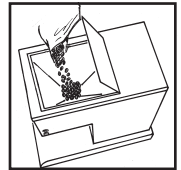

ADJUSTING THE GRINDS

1. Empty hopper of coffee beans. Run grinder to clear grinding burrs of coffee.
2. Open housing cover to locate adjustment screw (8) and lock nut (7). Loosen lock nut.
3. Run motor during adjustment. Turning adjustment screw clockwise will result in a finer grind (if, while turning, you hear the grinding burrs starting to touch, immediately, back off 1/8th turn). Turning counter clockwise will produce a coarser grind.
4. With a screwdriver holding the adjustment screw in place, tighten the locknut.
5. Run some coffee beans through the machine to check the grind adjustment.
6. Replace front cover on machine.

*This adjustment may change the amount of ground coffee dispensed.

CHANGING A BROKEN SHEAR DISK

1. Unplug the power cord.
2. Empty the hopper of beans.
3. Take out the thumb screws (10) to remove the grind cap (6).
4. Pull out the grinding burr/feed worm assembly (2). The inner half of the grinding burr set will remain in the housing.
5. Separate the shear cap (5) and shear drive (3). The snapped shear disk (4) should fall out of its slot on the shear drive.
6. Inspect and clean housing (1) of any coffee or debris. Especially look for anything that may have broken the shear disk.
7. Re-insert the feed worm and grinding burr on to the motor shaft.
8. Push shear drive through burr/feed worm assembly and align large slot with tongue on the motor shaft.
9. Rotate burr/feed worm assembly to align slot with narrow slot on shear drive.
10. Insert a new shear disk into slot. Cover with the shear cap.
11. Replace grind cap and thumb screws.

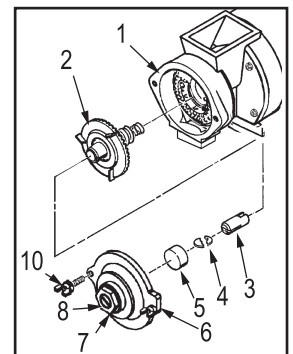

ISO 9001 REGISTERED

WILBUR CURTIS COMPANY
Montebello, CA 90640

TIMER SETTING – DHG

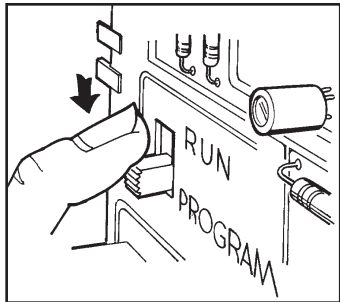

1. To set the timer, place an empty filter paper below the chute. Pour whole bean coffee into the hopper.
2. Open the lower cover to reveal the timer.
3. On the timer control board, locate the programming switch. Switch from RUN to PROG (see illustration, left).
4. On the front cover, select the desired switch to program, REGULAR or DECAF. Press and hold this switch.
5. The grinder motor and auger motor will start grinding coffee. When the desired ground coffee output is reached, release the grind switch. The auger motor will shut off, stopping the flow of coffee from the hopper. The grind motor will continue to run until the delay has elapsed.
6. Press the other grind button or move the program switch to RUN. This will save the time setting.
7. Repeat steps 1 to 7 for the other grind switch.



NOTE: Time settings in this table are only approximate. Amounts will vary with grind texture and specific coffee bean. Weigh your output, then make adjustments as necessary.

Seconds	Ounces	Seconds	Ounces
4	1.3	15	4.5
5	1.5	20	6.2
6	1.8	25	7.6
7	2.0	30	8.8
8	2.5	35	10.0
10	3.0	40	11.8
12	3.7	45	13.5

PARTS DIAGRAM MOTOR ASSY

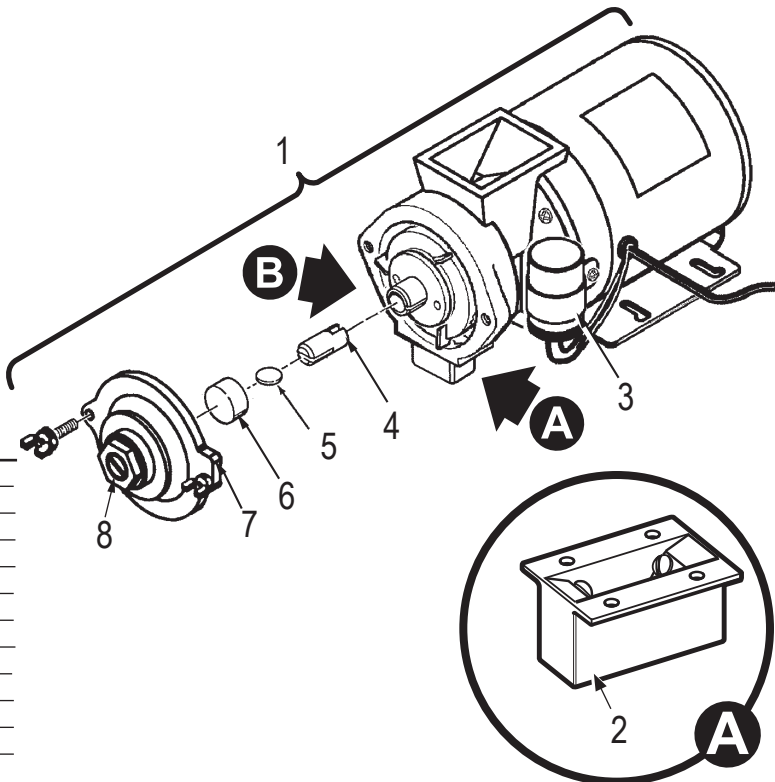
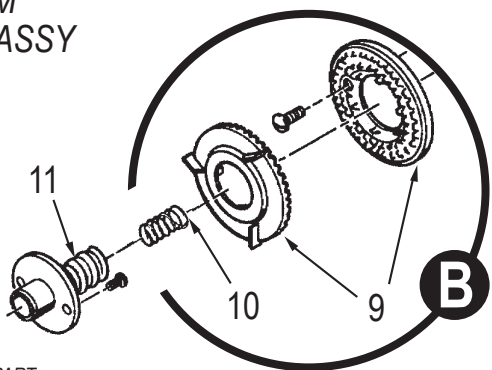

INDEX NUMBER	PART NUMBER	DESCRIPTION
1	WC-9135	MOTOR CRUSHING GRINDER ASSY 120VAC
2	WC-37283	KIT, GRINDER CHUTE NEW STYLE
3	WC-91026	CAPACITOR, COFFEE GRINDER ASSY
4	WC-91024	SHEAR DRIVE COFFEE GRINDER
5	WC-9107-6	DISC, SHEAR COFFEE GRINDER 6PCS
6	WC-91016	CAP, SHEAR DISK GRINDERS
7	WC-91017	COVER, GRINDER HOUSING W/LABEL
8	WC-91015	SCREW & THRUST PIN ADJUSTING ASSY
9	WC-91045	BURRS, SET CRUSH HIGH FLOW
10	WC-91021	SPRING, TENSION COFFEE GRINDER
11	WC-91020	WORM FEEDING ASSY CCG

PARTS DIAGRAMS

SHG Hopper & Covers

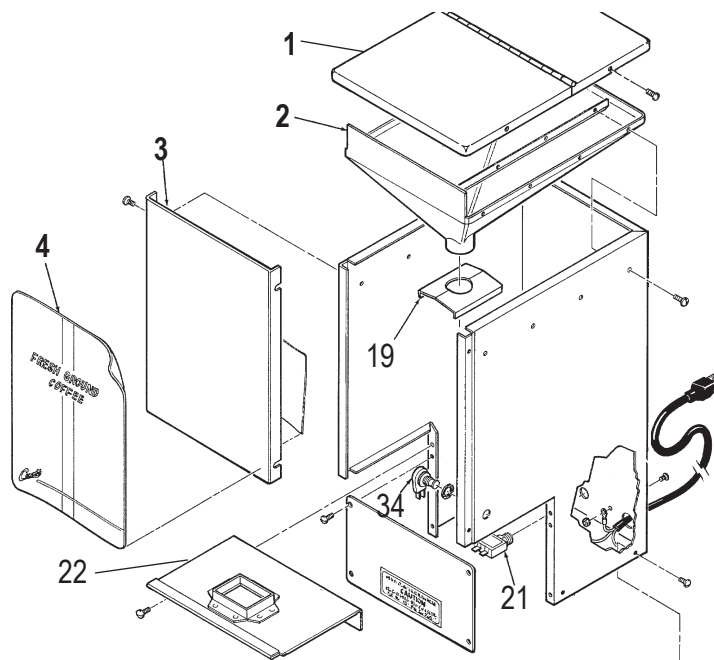
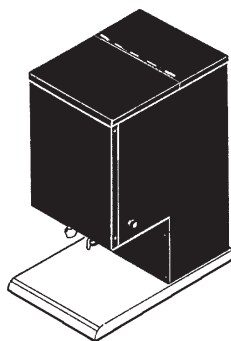

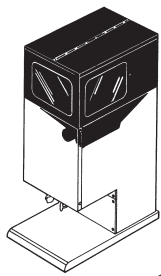

Hopper & Top Cover
DHG Only

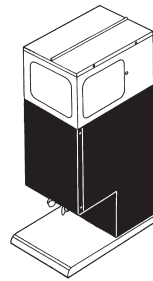
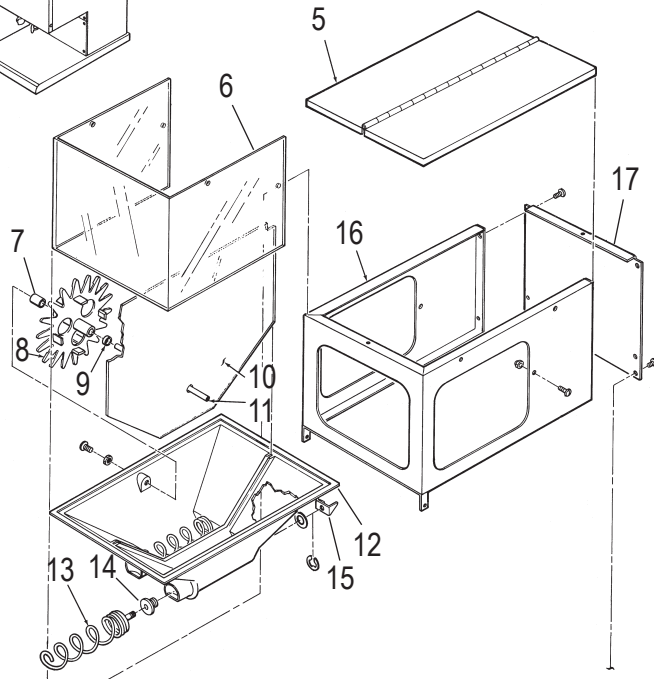

Center Cover & Gear Motor
DHG Only

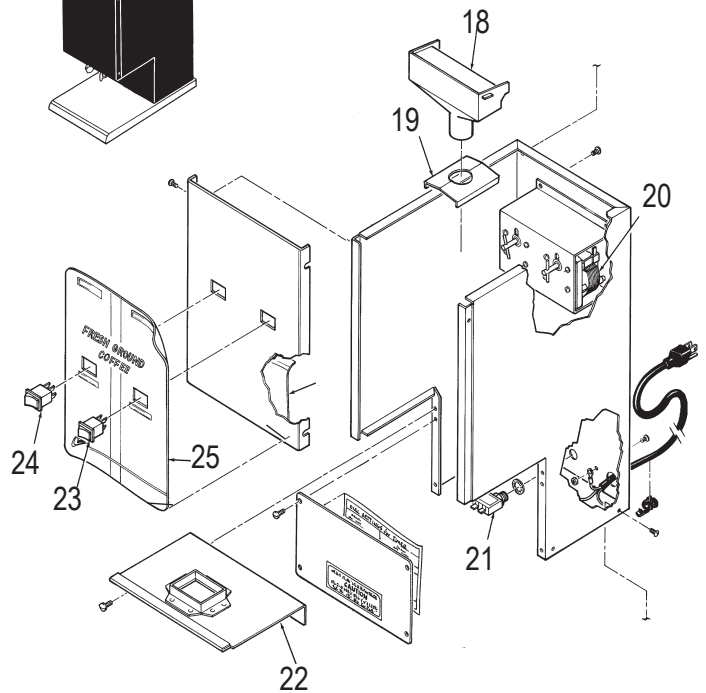

Item	Part No.	Description
1	WC-9129	COVER, TOP ASSEMBLY SHG
2	WC-9117	HOPPER, COFFEE BEAN SHG
3	WC-9165	COVER, FRONT SHG
4	WC-3891	LABEL, SHG
5	WC-9118	TOP COVER, DUAL HOPPER DHG
6	WC-9131	ACRYLIC GLASS WINDOW
7	WC-9143	SPACER, 5/16 x 1/2 x 5/8 (OPTIONAL)
8	WC-9160	STAR WHEEL (OPTIONAL)
9	WC-9144	SPACER, 5/16 x 1/2 x 9/32 (OPTIONAL)
10	WC-9132	DIVIDER, DUAL HOPPER SS DHG, ILGD (OPTIONAL)
10A	WC-9188	DIVIDER, W/HOLE ILG-11/DHG-11
11	WC-9142	SHAFT FOR STAR WHEEL (OPTIONAL)
12	WC-9116	HOPPER, DUAL
13	WC-9158	AUGER ANCHOR
14	WC-9183	BEARING, AUGER
15	WC-9157	DRIVE FOR AUGER
16	WC-9161	WRAP, HOPPER ASSY DHG, ILG
17	WC-9146	PANEL, TOP BACK
18	WC-9130	FUNNEL, DUAL HOPPER
19	WC-9134	CAP SEAL, S/S
20	WC-9151	GEAR MOTOR
21	WC-1504	CIRCUIT BREAKER, 10A
22	WC-9164	COVER ASSEMBLY, SPOUT & ARM
23	WC- 124	SWITCH, DECAF, 115V (H/W)
24	WC- 122	SWITCH, REGULAR COFFEE (BRW)
25	WC-3892	LABEL, SWITCH PANEL DHG
26	WC-9135	MOTOR, 1/2 HP, 120V, 1725 RPM
27	WC- 644	TIMER, GRINDER 120V 50SEC. MAX
27A	WC- 628	TIMER, 120V .5-60 SEC SHG
28	WC-3503	LEG, 3/8"-16 STUD SCREW BUMPER
28A	WC-3518	LEG, GLIDE 3/8"-16 STUD SCREW
29	WC-3502	BUMPER LEG, 8-32 THREAD (OLDER UNITS)
30	WC-9141	BASKET HOLDER
31	WC-9155	SPRING, BASKET HOLDER
32	WC-9123	NUT, HEX, 5/8 X 11/16 LONG
33	WC-4813	SCREW, 5/16 x 5/8 LONG SHOULDER
34	WC-37283	KIT, GRINDER CHUTE NEW STYLE
35	WC-9107-6	SHEAR DISK

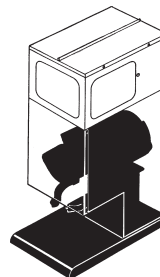

Motor & Base
DHG & SHG

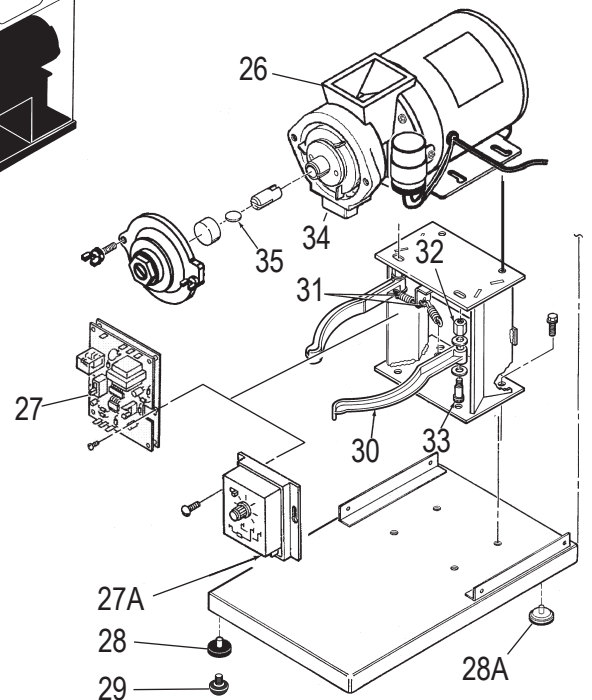

ELECTRICAL SCHEMATIC

DHG

DIAGRAM NO.: WD-DHG-10	PART NO.: DHG-10 GRINDER	WIRES: 2+GND	CYCLE: 60	WATTAGE: 1/2 HP	DRAWN BY: YT	CHECKED:	APPROVED:	EDR/ECN NO.: 10375	REV: E
		PHASE: 1	VOLTAGE: 120	AMPERAGE: 8	DATE: 4/16/09	DATE:	DATE:		

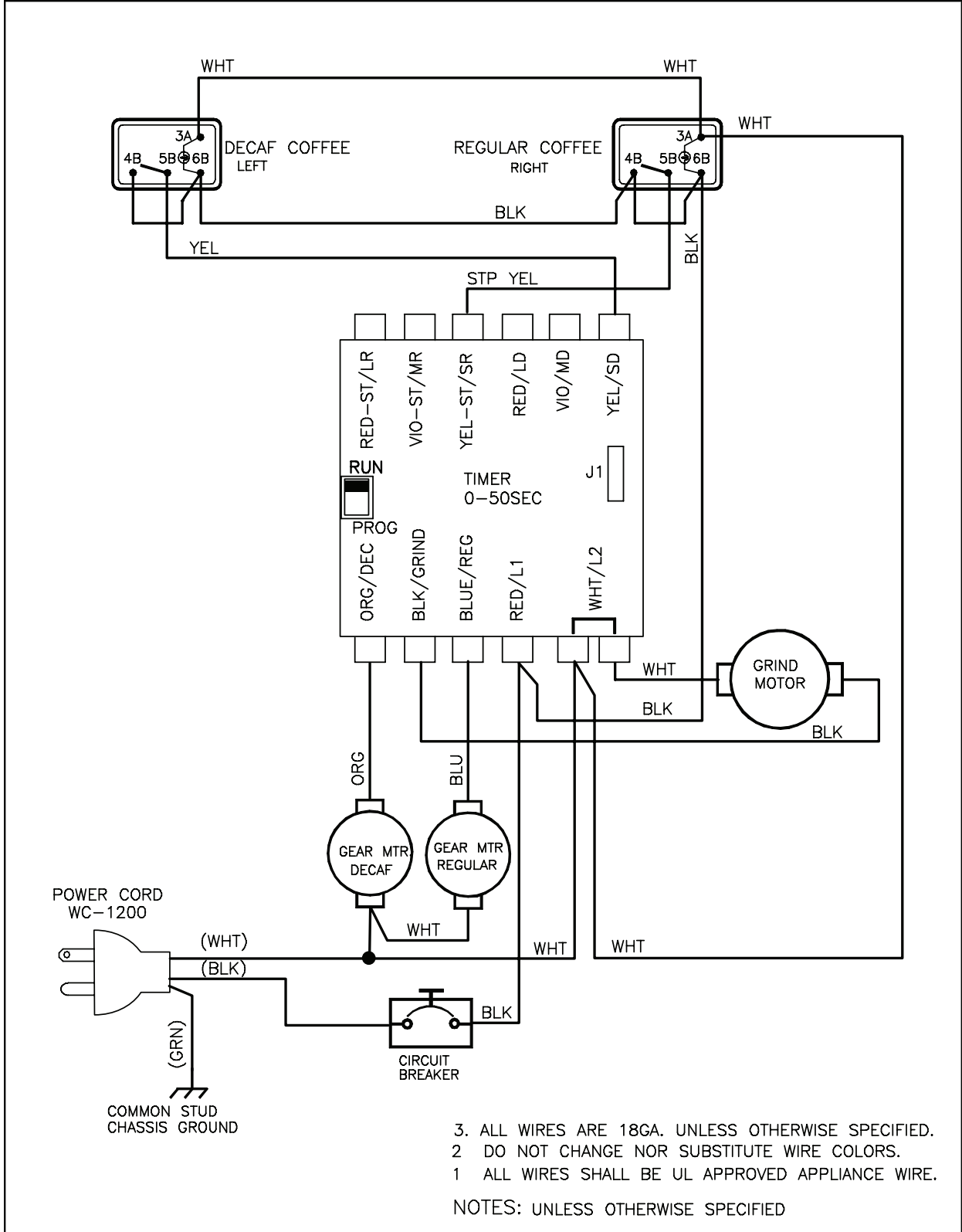

- 3. ALL WIRES ARE 18GA. UNLESS OTHERWISE SPECIFIED.
- 2. DO NOT CHANGE NOR SUBSTITUTE WIRE COLORS.
- 1. ALL WIRES SHALL BE UL APPROVED APPLIANCE WIRE.

NOTES: UNLESS OTHERWISE SPECIFIED

ELECTRICAL SCHEMATIC

SHG

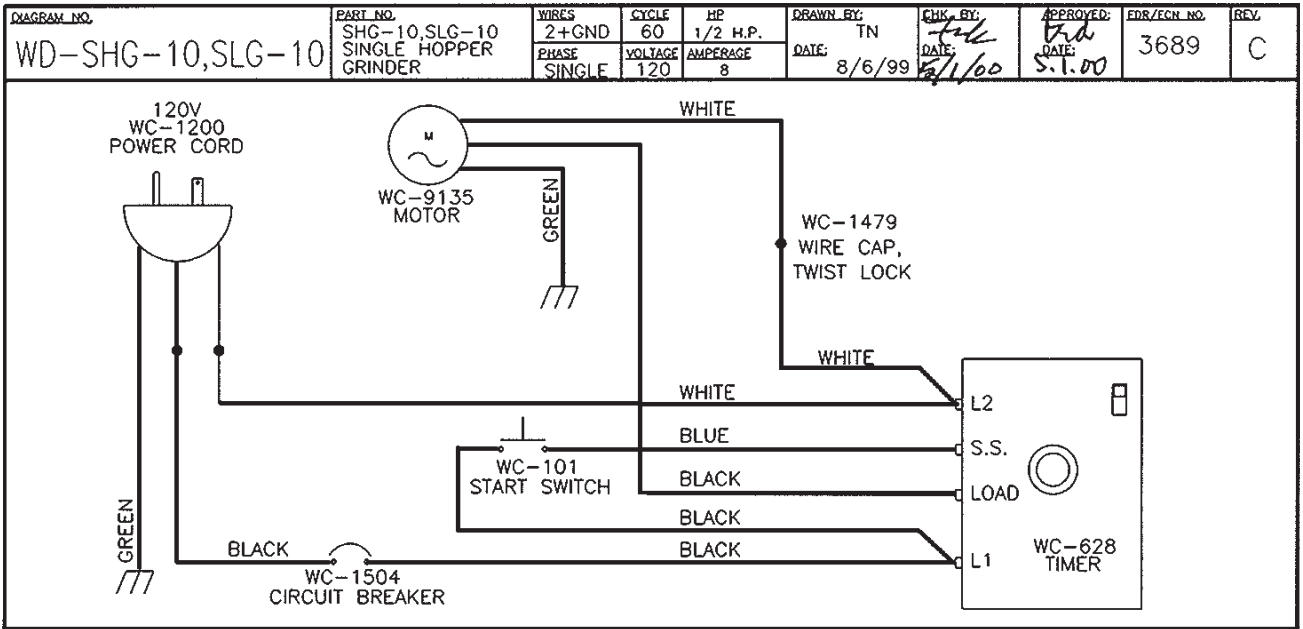

ROUGH-IN DRAWINGS

DHG

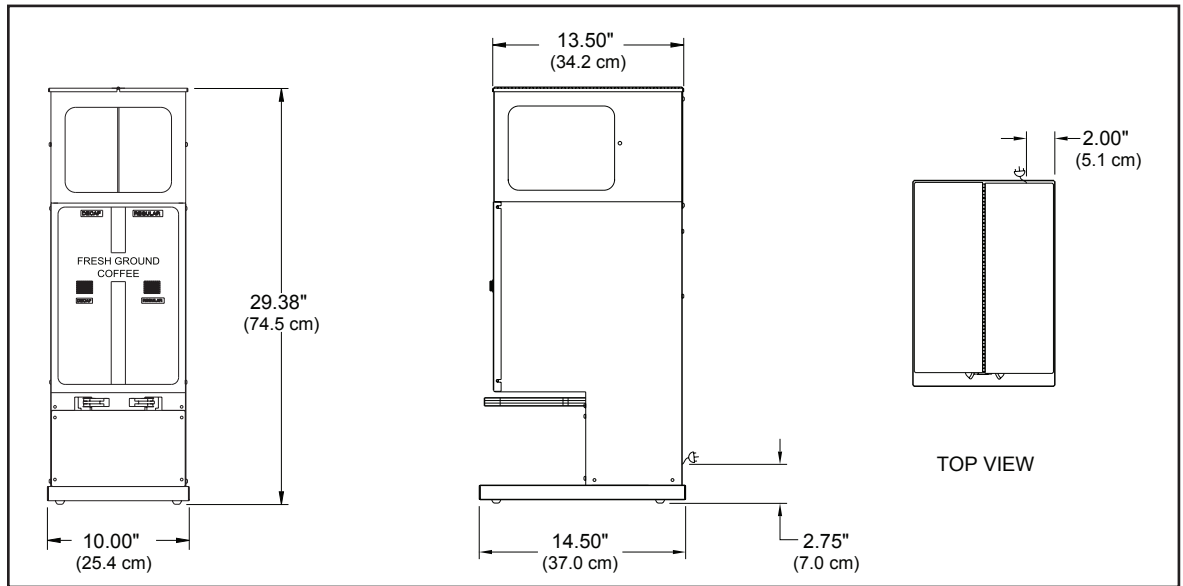

SHG

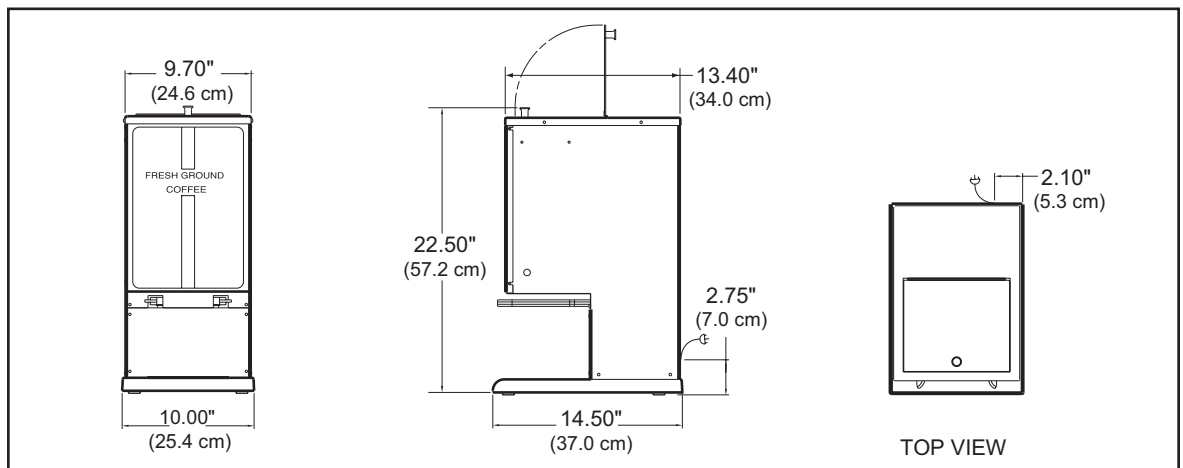

Product Warranty Information

The Wilbur Curtis Company certifies that its products are free from defects in material and workmanship under normal use. The following limited warranties and conditions apply:

3 Years, Parts and Labor, from Original Date of Purchase on digital control boards.

2 Years, Parts, from Original Date of Purchase on all other electrical components, fittings and tubing.

1 Year, Labor, from Original Date of Purchase on all electrical components, fittings and tubing.

Additionally, the Wilbur Curtis Company warrants its Grinding Burrs for Forty (40) months from date of purchase or 40,000 pounds of coffee, whichever comes first. Stainless Steel components are warranted for two (2) years from date of purchase against leaking or pitting and replacement parts are warranted for ninety (90) days from date of purchase or for the remainder of the limited warranty period of the equipment in which the component is installed.

All in-warranty service calls must have prior authorization. For Authorization, call the Technical Support Department at 1-800-995-0417. Effective date of this policy is April 1, 2003.

Additional conditions may apply. Go to www.wilburcurtis.com to view the full product warranty information.

CONDITIONS & EXCEPTIONS

The warranty covers original equipment at time of purchase only. The Wilbur Curtis Company, Inc., assumes no responsibility for substitute replacement parts installed on Curtis equipment that have not been purchased from the Wilbur Curtis Company, Inc. The Wilbur Curtis Company will not accept any responsibility if the following conditions are not met. The warranty does not cover and is void under the following circumstances:

- 1) Improper operation of equipment: The equipment must be used for its designed and intended purpose and function.
- 2) Improper installation of equipment: This equipment must be installed by a professional technician and must comply with all local electrical, mechanical and plumbing codes.
- 3) Improper voltage: Equipment must be installed at the voltage stated on the serial plate supplied with this equipment.
- 4) Improper water supply: This includes, but is not limited to, excessive or low water pressure, and inadequate or fluctuating water flow rate.
- 5) Adjustments and cleaning: The resetting of safety thermostats and circuit breakers, programming and temperature adjustments are the responsibility of the equipment owner. The owner is responsible for proper cleaning and regular maintenance of this equipment.
- 6) Damaged in transit: Equipment damaged in transit is the responsibility of the freight company and a claim should be made with the carrier.
- 7) Abuse or neglect (including failure to periodically clean or remove lime accumulations): Manufacturer is not responsible for variation in equipment operation due to excessive lime or local water conditions. The equipment must be maintained according to the manufacturer's recommendations.
- 8) Replacement of items subject to normal use and wear: This shall include, but is not limited to, light bulbs, shear disks, "O" rings, gaskets, silicone tube, canister assemblies, whipper chambers and plates, mixing bowls, agitation assemblies and whipper propellers.
- 9) Repairs and/or Replacements are subject to our decision that the workmanship or parts were faulty and the defects showed up under normal use. All labor shall be performed during regular working hours. Overtime charges are the responsibility of the owner. Charges incurred by delays, waiting time, or operating restrictions that hinder the service technician's ability to perform service is the responsibility of the owner of the equipment. This includes institutional and correctional facilities. The Wilbur Curtis Company will allow up to 100 miles, round trip, per in-warranty service call.

RETURN MERCHANDISE AUTHORIZATION: All claims under this warranty must be submitted to the Wilbur Curtis Company Technical Support Department prior to performing any repair work or return of this equipment to the factory. All returned equipment must be repackaged properly in the original carton. No units will be accepted if they are damaged in transit due to improper packaging. **NO UNITS OR PARTS WILL BE ACCEPTED WITHOUT A RETURN MERCHANDISE AUTHORIZATION (RMA). RMA NUMBER MUST BE MARKED ON THE CARTON OR SHIPPING LABEL.** All in-warranty service calls must be performed by an authorized service agent. Call the Wilbur Curtis Technical Support Department to find an agent near you.



WILBUR CURTIS CO., INC.

6913 Acco St., Montebello, CA 90640-5403 USA

Phone: 800/421-6150 ♦ Fax: 323-837-2410

♦ Technical Support Phone: 800/995-0417 (M-F 5:30A - 4:00P PST) E-Mail: techsupport@wilburcurtis.com

♦ Web Site: www.wilburcurtis.com

FOR THE LATEST SPECIFICATION INFORMATION GO TO WWW.WILBURCURTIS.COM

Printed in U.S.A. 6/09 F-3209-S Rev B