



# CATALOG OF

## REPLACEMENT PARTS

### ROLLTOP TABLE

#### HRT 1-6

HRT 1	ML-44090
HRT 2	ML-44091
HRT 3	ML-44092
HRT 4	ML-44098
HRT 5	ML-44188
HRT 6	ML-44190

### GRAVITY ROLLER CONVEYOR

UWS GRVCON ML-44191

### LABEL RACK ACCESSORY

HRT LD 136  
HRT LD 236  
HRT LD 248

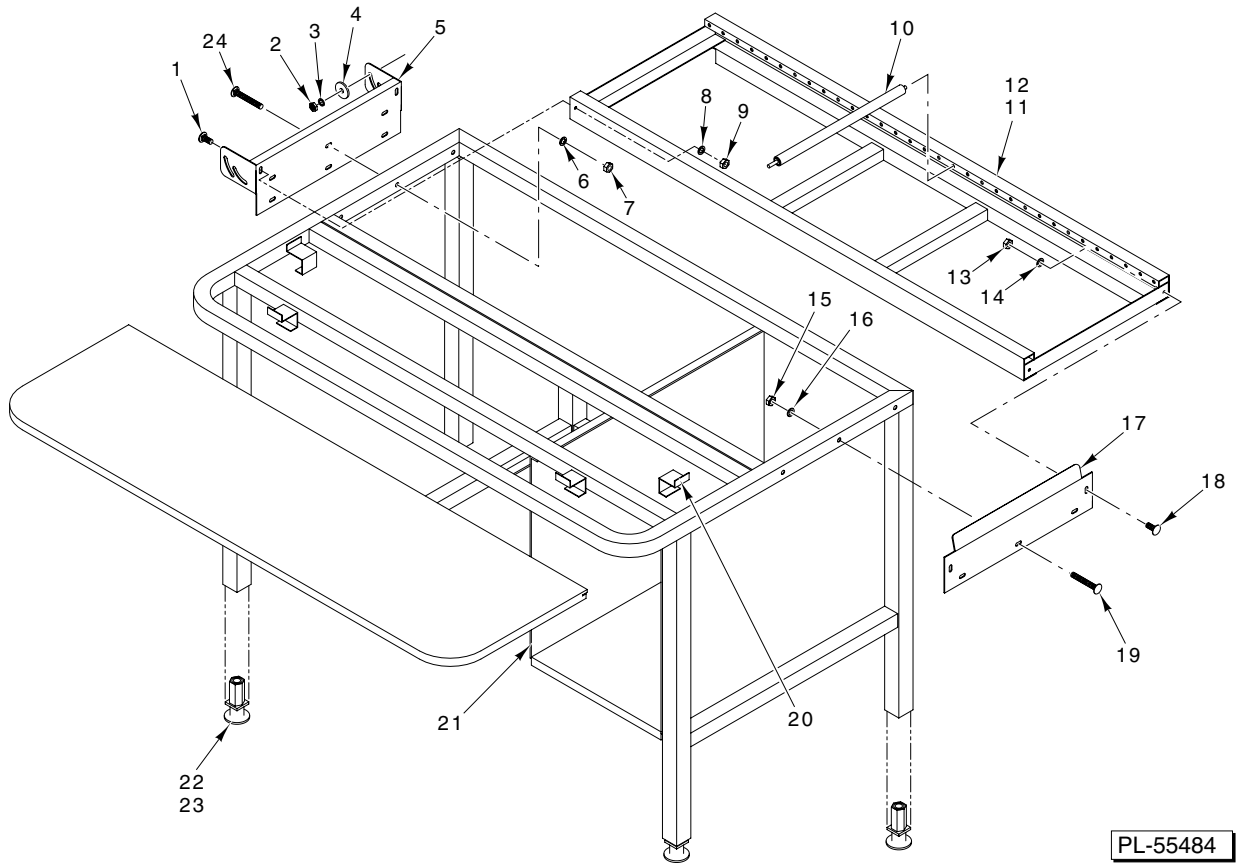

PLATTER RECEIVING TABLE

**PLATTER RECEIVING TABLE**

ILLUS. PL-55484	PART NO.	NAME OF PART	HRT	HRT	HRT	HRT	HRT	HRT
			1	2	3	4	5	6
1	SC-094-26	Bolt – Carriage 1/4-20 x 1/2 .....	2	2	2	2	2	2
2	NS-015-01	Nut 1/4-20 Hex .....	4	4	4	4	4	4
3	WL-006-17	Lockwasher 1/4 .....	4	4	4	4	4	4
4	WS-030-84	Washer .....	4	4	4	4	4	4
5	00-044960	Bracket – Conveyor Mounting .....	1	1	1	1	1	1
6	WL-006-17	Lockwasher 1/4 .....	3	3	3	3	3	3
7	NS-015-01	Nut 1/4-20 Hex .....	3	3	3	3	3	3
8	WL-006-17	Lockwasher 1/4 .....	2	2	2	2	2	2
9	NS-015-01	Nut 1/4-20 Hex .....	2	2	2	2	2	2
10	00-049999	Roller Assy. (Spring Loaded) .....	24	24	32	24	24	32
11	00-440658	Rail Assy. – Conveyor .....	-	-	1	-	-	1
12	00-046339	Rail Assy. – Conveyor .....	1	1	-	1	1	-
13	NS-015-01	Nut 1/4-20 Hex .....	2	2	2	2	2	2
14	WL-006-17	Lockwasher 1/4 .....	2	2	2	2	2	2
15	NS-015-01	Nut 1/4-20 Hex .....	3	3	3	3	3	3
16	WL-006-17	Lockwasher 1/4 .....	3	3	3	3	3	3
17	00-044957	Plate – Stop .....	1	1	1	1	1	1
18	SC-094-26	Bolt – Carriage 1/4-20 x 1/2 .....	2	2	2	2	2	2
19	SC-118-60	Bolt – Sq. Neck 1/4-20 x 1 3/4 .....	3	3	3	3	3	3
20	00-440035	Bracket – Table Clip .....	-	-	-	-	4	4
21	00-046341	Strip – Protection .....	1	1	1	1	-	-
22	00-048393	Foot – Insert .....	-	-	-	-	6	6
23	00-046342	Leg (Adjustable) .....	4	4	4	4	-	-
24	SC-118-60	Bolt – Sq. Neck 1/4-20 x 1 3/4 .....	3	3	3	3	3	3
	00-252217-00001	Hobart Logo (Not Shown) .....	1	1	1	1	-	-

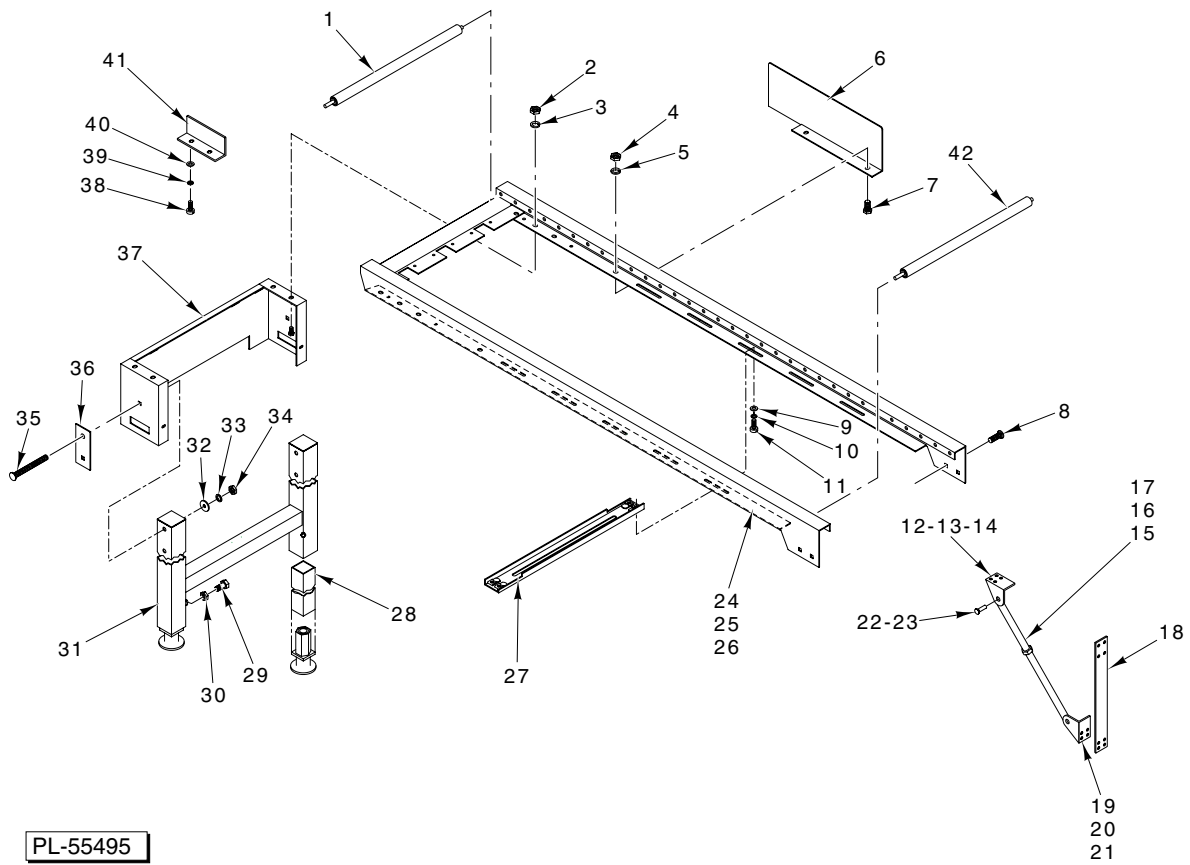

CONVEYOR ROLLER TABLE

CONVEYOR ROLLER TABLE

ILLUS. PL-55495	PART NO.	NAME OF PART	HRT	HRT	HRT	HRT	HRT	HRT
			1	2	3	4	5	6
1	00-440003	Roller Assy. (Teflon Coated) .....	-	-	-	-	8	8
2	NS-015-01	Nut 1/4-20 Hex .....	-	-	-	-	4	4
3	WL-006-17	Lockwasher 1/4 .....	-	-	-	-	4	4
4	NS-015-01	Nut 1/4-20 Hex .....	-	-	-	-	2	2
5	WL-006-17	Lockwasher 1/4 .....	-	-	-	-	2	2
6	00-440033	Plate – Stop Conveyor .....	-	-	-	-	1	1
7	SC-041-50	Cap Screw 1/4-20 x 1/2 Hex .....	-	-	-	-	2	2
8	SC-082-13	Bolt – Sq. Neck 1/4-20 x 5/8 .....	6	8	8	8	4	4
9	WL-004-40	Lockwasher #10 Helical .....	-	-	-	-	4	4
10	WS-019-06	Washer .....	-	-	-	-	4	4
11	SC-093-07	Mach. Screw 10-32 x 5/8 Pan Hd. ....	-	-	-	-	4	4
12	00-044955	Bracket – Pivot .....	2	1	1	-	-	-
13	SC-093-07	Mach. Screw 10-32 x 1/2 .....	4	2	2	-	-	-
14	NS-031-49	Stop Nut 10-32 Special .....	4	2	2	-	-	-
15	00-032977	Tube – Lower Support .....	2	1	1	-	-	-
16	00-032976	Tube – Upper Support .....	2	1	1	-	-	-
17	NS-015-13	Nut 3/8-16 Hex (SST) .....	1	1	1	-	-	-
18	00-044956	Bracket – Mounting Support Tube .....	1	-	-	-	-	-
19	00-044955	Bracket – Pivot .....	2	1	1	-	-	-
20	SC-041-05	Cap Screw 1/4-20 x 5/8 .....	4	2	2	-	-	-
21	WL-006-17	Lockwasher 1/4 .....	4	2	2	-	-	-
22	00-044868	Pin – Clevis .....	4	2	2	-	-	-
23	PC-003-78	Pin – Cotter .....	4	2	2	-	-	-
24	00-032979	Rail Assy. (Conveyor Infeed) .....	1	1	1	-	-	-
25	00-046340	Rail Assy. (Conveyor Infeed) .....	-	-	-	1	-	-
26	00-440032	Rail Assy. (Conveyor Infeed) .....	-	-	-	-	1	1
27	00-048359	Cross Member – Dispenser .....	-	-	-	-	2	2
28	00-440042	Tube – Inner Leg .....	-	-	-	-	2	2
29	SC-041-05	Cap Screw 1/4-20 x 5/8 .....	-	-	-	-	2	2
30	NS-015-01	Nut 1/4-20 Hex .....	-	-	-	-	2	2
31	00-048332	Leg Assy. ....	-	-	-	-	1	1
32	WS-030-84	Washer .....	-	-	-	-	4	4
33	WL-006-17	Lockwasher 1/4 .....	-	-	-	-	4	4
34	NS-015-01	Nut 1/4-20 Hex .....	-	-	-	-	4	4
35	SC-124-19	Bolt – Sq. Neck 1/4-20 x 2 1/4 .....	-	-	-	-	4	4
36	00-048340	Plate – Flat .....	-	-	-	-	2	2
37	00-048356	Bracket – Leg Mounting .....	-	-	-	-	1	1
38	SC-093-07	Mach. Screw 10-32 x 1/2 .....	2	2	2	-	-	-
39	WL-019-20	Washer .....	2	2	2	-	-	-
40	NS-031-49	Stop Nut 10-32 Special .....	2	2	2	-	-	-
41	00-044958	Guide – Product .....	1	1	1	-	-	-
42	00-049999	Roller Assy. (Spring Loaded) .....	16	16	16	6	24	24

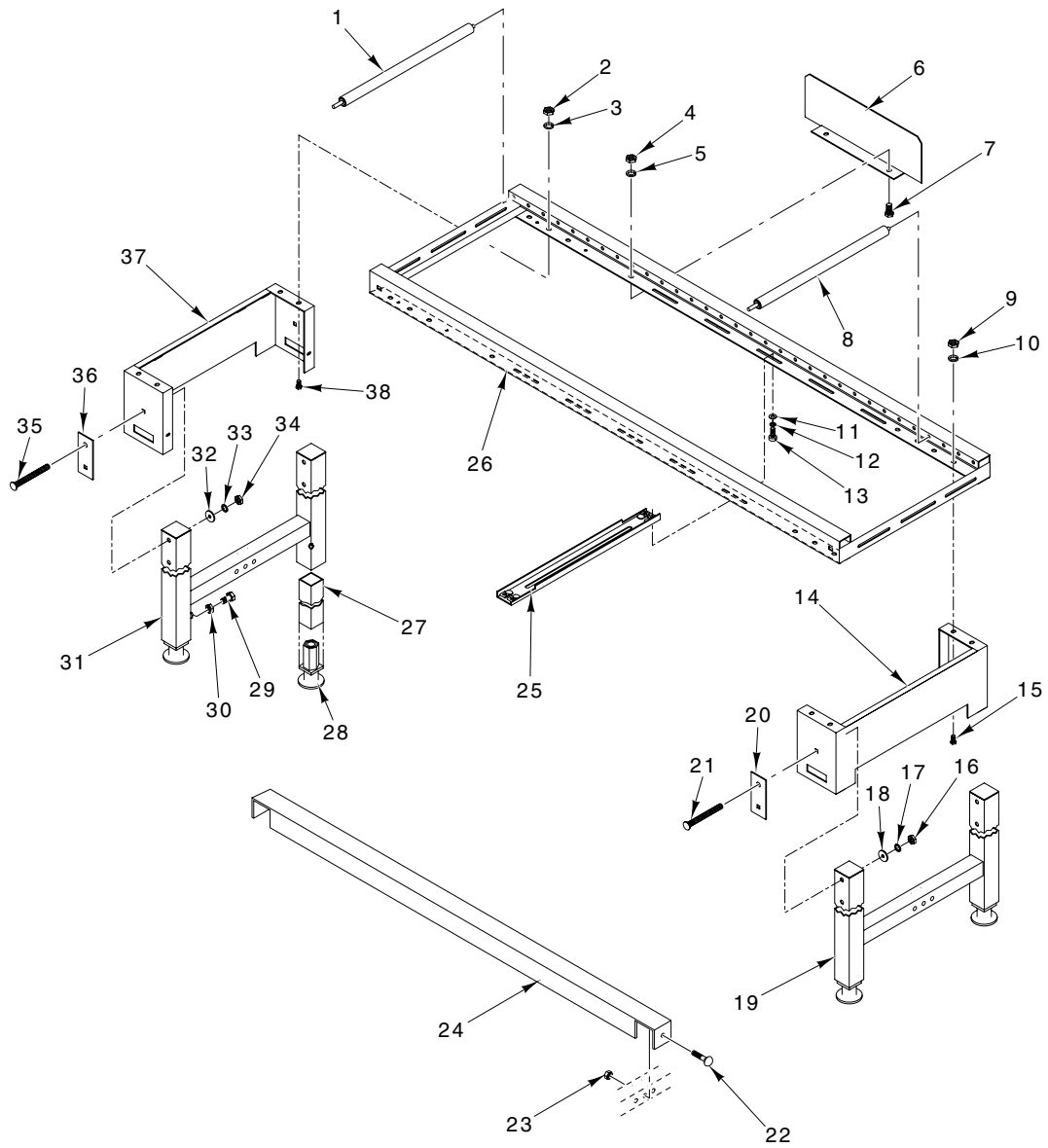

PL-55508

**GRAVITY ROLLER CONVEYOR**

**GRAVITY ROLLER CONVEYOR**

ILLUS. PL-55508	PART NO.	NAME OF PART	AMT.
1	00-440003	Roller Assy. (Teflon Coated) .....	8
2	NS-015-01	Nut 1/4-20 Hex .....	4
3	WL-006-17	Lockwasher 1/4 .....	4
4	NS-015-01	Nut 1/4-20 Hex .....	2
5	WL-006-17	Lockwasher 1/4 .....	2
6	00-441647	Plate – Conveyor Stop .....	1
7	SC-041-50	Cap Screw 1/4-20 x 1/2 Hex Hd. ....	2
8	00-049999	Roller Assy. (Spring Loaded) .....	22
9	NS-015-01	Nut 1/4-20 Hex .....	4
10	WL-006-17	Lockwasher 1/4 .....	4
11	WS-019-06	Washer .....	8
12	WL-004-40	Lockwasher #10 Helical .....	8
13	SC-093-07	Mach. Screw 10-32 x 1/2 Pan Hd. ....	8
14	00-048356	Bracket – Leg Mounting .....	1
15	SC-041-50	Cap Screw 1/4-20 x 1/2 Hex Hd. ....	4
16	NS-015-01	Nut 1/4-20 Hex .....	4
17	WL-006-17	Lockwasher 1/4 .....	4
18	WS-030-84	Washer .....	4
19	00-440001	Leg Assy. ....	1
20	00-048340	Plate – Flat .....	2
21	SC-124-19	Bolt – Carriage 1/4-20 x 2 1/4 .....	4
22	SC-094-26	Bolt – Carriage 1/4-20 x 1/2 .....	2
23	NS-015-01	Nut 1/4-20 Hex .....	2
24	00-441646	Cross Member – Center (Leg) .....	1
25	00-048359	Cross Member – Label Dispenser .....	2
26	00-441645	Frame Assy. ....	1
27	00-048357	Tube – Inner Leg .....	4
28	00-048393	Foot – Insert .....	4
29	SC-041-05	Cap Screw 1/4-20 x 5/8 .....	4
30	NS-015-01	Nut 1/4-20 Hex .....	4
31	00-048332	Leg Assy. ....	1
32	WS-030-84	Washer .....	4
33	WL-006-17	Lockwasher 1/4 .....	4
34	NS-015-01	Nut 1/4-20 Hex .....	4
35	SC-124-19	Bolt – Carriage 1/4-20 x 2 1/4 .....	4
36	00-048340	Plate – Flat .....	2
37	00-048356	Bracket – Leg Mounting .....	1
38	SC-041-50	Cap Screw 1/4-20 x 1/2 Hex Hd. ....	4

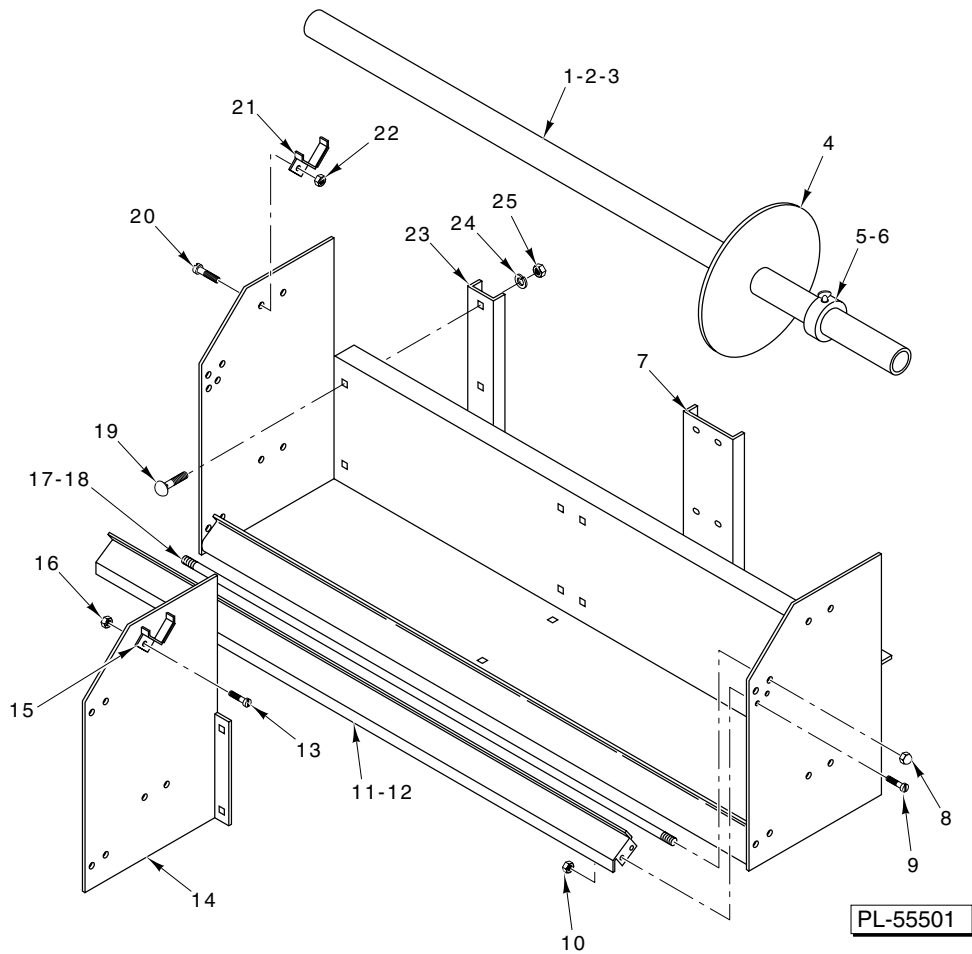

**LABEL DISPENSER**

ILLUS.	PART NO.	NAME OF PART	SINGLE 36 IN	DUAL 36 IN	DUAL 48 IN
1	00-032988	Tube – Label Dispenser .....	-	-	4
2	00-032995	Tube – Label Dispenser .....	-	4	-
3	00-044867	Tube – Label Dispenser .....	1	-	-
4	00-184854	Disc – Label Separator (Kit of 40) .....	1	1	1
5	00-032992	Collar – Film Dispenser .....	2	8	8
6	00-046390	Screw – Thumb 10-32 .....	2	8	8
7	00-032985	Bracket – Support .....	-	-	1
8	NS-025-04	Nut – Acorn .....	4	8	8
9	SC-093-03	Mach. Screw 8-32 x 3/8 Pan Hd. ....	-	4	4
10	NS-031-08	Stop Nut 8-32 Special .....	-	4	4
11	00-032991	Bracket – Label .....	-	-	1
12	00-032996	Bracket – Label .....	-	1	-
13	SC-093-07	Mach. Screw 10-32 x 1/2 Pan Hd. ....	-	4	4
14	00-032984	Divider .....	-	1	1
15	00-032987	Bracket – Tube Support .....	-	4	4
16	NS-031-49	Stop Nut 10-32 Special .....	-	4	4
17	00-032990	Shaft – Label Dispenser .....	-	-	4
18	00-032994	Shaft – Label Dispenser .....	2	4	-
19	SC-082-13	Bolt – Sq. Neck 1/4-20 x 5/8 .....	4	8	10
20	SC-093-21	Mach. Screw 10-32 x 3/8 Pan Hd. ....	4	8	8
21	00-032987	Bracket – Tube Support .....	2	4	4
22	NS-031-49	Stop Nut 10-32 Special .....	4	10	10
23	00-032986	Bracket – Mounting .....	2	2	2
24	WL-006-17	Lockwasher 1/4 .....	4	12	16
25	NS-015-01	Nut 1/4-20 Hex .....	4	8	10
	SC-041-05	Cap Screw 1/4-20 x 3/8 .....	4	4	6