



FORK KNEADING MACHINE | FC - US SERIES

USE AND MAINTENANCE MANUAL



SUMMARY

CHAPTER 1 | INTRODUCTION

1.1 Introduction	4
1.2 Warnings	4
1.3 Installation and transportation	5
1.4 Electrical Connections	6
1.5 Warranty	6

CHAPTER 2 | EQUIPMENT DESCRIPTION

2.1 Technical and Identification Data	7
2.2 Machine description and main elements	8
2.3 Control Panel	9
2.4 Accident Prevention Protections	9
2.4.1 Mechanical Protections	10
2.4.2 Electrical Protections	10

CHAPTER 3 | CLEANING AND MAINTENANCE

3.1 General Guidelines	12
3.2 Cleaning the Machine	12
3.3 Standard Maintenance	12
3.4 Extraordinary Maintenance	13
3.5 Spare Parts	13

Preface

This manual is specifically for the installation, use and maintenance of the machines. So you are able to use the product in the best way. It is important that the manual is kept in good condition and should stay with the machine at all times, including sale to another person, for security in the use of the machine.

The manufacturer is not under any obligation to notify of any further modification of the product. All rights of this document are reserved and no alternation or reproductions can be made without permission of the manufacturer.

CHAPTER 1 | INTRODUCTION

1.1 Introduction

Dear Customer, Thank you for choosing a Mecnosud S.r.l. fork kneading machine. By using it properly, in compliance with safety regulations and with all the guidelines mentioned in this manual, your Mecnosud kneading machine will be a safe and reliable tool. Before installing, using, maintaining and performing any operation on the machine, read carefully this manual and comply with all the safety requirements contained herein.

1.2 Warnings

This Use and Maintenance Manual must be attached to the machine and made available to all operators (users and technicians) who may be involved with it. The manual must be transferred along with the machine in case of assignment for sale, maintenance, repair, etc. Operators using the fork kneading machine for their daily work must be professionally prepared for its use.

Before using the machine, make sure that all the mechanical and electromechanical safety devices are operating according to what has been listed in the various sections of this manual. In case of failure or malfunction of such devices, contact immediately the manufacturer or your authorized dealer. The safety devices must not be removed for any reason.

Prior to performing any handling, cleaning, maintenance, and similar activity, it is necessary to disconnect the machine from the electrical line. These activities must be performed exclusively by qualified personnel and in accordance with applicable safety regulations. The manufacturer disclaims any liability for damages arising from failure to comply with these regulations. Personnel using the machine or performing any other work-related activity with it must be dressed in accordance with health and safety standards in force, and in any case must be certain to wear clothing that does not leave limbs or edges exposed in any such way to allow contact with the rotating parts of the kneading machine.

Mecnosud fork kneading machine has been designed solely for flour and water based dough, in order to produce pizza, bread and other baked products. Any other use of the machine is deemed an unintended use and voids all warranty. The Company declines any responsibility for damages that may arise from the unintended use of the machine.

1.3 Installation and transportation

The machine must be installed in premises that comply with current regulations in force. It must be placed on a flat and solid floor, easy to be cleaned and suitable to support the load. It must be positioned so as to allow immediate access to every of its points. The floor, walls and any other element of the premises must be constructed in accordance with reference regulations for health and safety. The electrical installation must also be performed in compliance with reference standards and as indicated in the manual for use.

The machine is shipped assembled and packed in a cardboard box or other suitable material, or laid on a pallet and properly anchored. The machine can be loaded and unloaded using a forklift or crane. All means used must have suitable capacity and characteristics to handle the weight of the load. For the weight of the machine, see the paragraph related to technical and identification data. Handling must be performed with utmost care, considering the loads and the weight distribution of the machine.

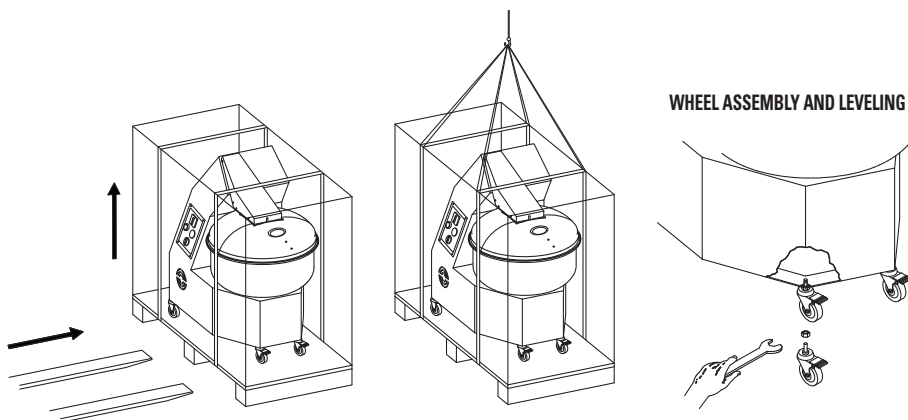

All the operations referred to in this paragraph must be performed exclusively by trained personnel, equipped with all the tools adequate to the related activities.

During transportation, all necessary precautions must be taken to avoid damage of the machine. Transportation and placement at the point of use must be carried out without removing the packaging of the machine. After reaching the workstation, remove the packaging from the machine, verify its integrity and place it in the most appropriate location. Assemble the wheels (the front ones with brake), and verify that the machine is steady and well leveled before proceeding with the other operations.

It is not recommended to operate the machine without the wheels installed.

1.4 Electrical Connections

The electrical connections must be carried out only by qualified personnel pursuant to the requirements of the law in force. Each operation described in this section must be carried out after disconnecting the machine from the line. All electrical components used for the connection and not provided by the manufacturer (switches, plugs, etc.), must have adequate capacity to meet the electrical requirements of the machine shown in the identification nameplate located on the back of the machine.

Verify that the voltage of the electrical system at the premises matches the one required by the machine. The machine must be connected to a manually controlled electrical device that allows separating the electrical system of the machine from the line, whenever necessary (maintenance or handling). The machine is equipped with an electrical cable located on its side. Make sure that it is free from defects and that it has not received any damage during transportation and handling. After connecting the electrical cable to the plug, make sure that the direction of rotation of the bowl is the one indicated by the arrow found the edge of the machine. If this is not the case, reverse wire A and wire B. After having checked the rotation direction of the bowl, the machine is ready for use.

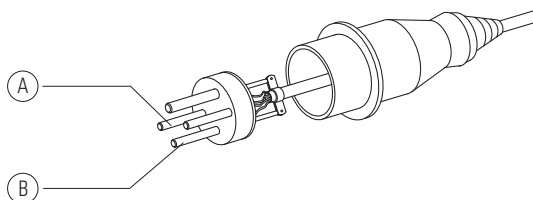

1.5 Warranty

Mecnosud offers a warranty on all components of this machine, with the exception of electrical parts, for a period of TWO YEARS from the date of purchase to be proven through a purchase receipt or invoice. Mecnosud agrees to replace or repair any defective parts. All failures resulting from improper installation, maintenance, misuse, tampering or activities different from what is stated in this manual are excluded from the warranty.

Any machine to be repaired must shipped at the expense and risk of the buyer. Every maintenance activity must be carried out only by authorized Mecnosud service centers.

CHAPTER 2 | EQUIPMENT DESCRIPTION

2.1 Technical and Identification Data

Mecnosud's fork kneading machine is manufactured in painted sheet-steel carpentry that houses and protects all the mechanical and transmission elements. It is equipped with a motor and two reduction gears placed in an oil bath and independent for the bowl and fork. Transmission occurs by means of trapezoidal belts and pulleys in cast iron.

It is painted with approved non-toxic epoxy paint for food use in compliance with the regulations in force. The fork, shaft holding the tool, bowl, and protection grille (for the 60Kg and 80 Kg versions) are in stainless steel. Mecnosud fork kneading machine is available in models with a dough capacity ranging from 25kg to 80 Kg and the various versions are as shown in the following table:

Model	Dough capacity Kg	Flour capacity Kg	Bowl volume L	Motor power Kw	Volt	Dimensions			Weight Kg
						A	C	B	
FC25US	25	16	30	1,5	220-240/60/1	850	500	755	140
FC25DUS	25	16	30	1,1	208-220/60/3	850	500	755	140
FC35MUS	35	23	40	1,5	220-240/60/1	850	550	755	145
FC35DUS	35	23	40	1,1	208-220/60/3	850	550	755	145
FC60DUS	60	40	70	1,5	208-220/60/3	1068	660	1025	240
FC80DUS	80	53	93	2,2	208-220/60/3	1110	744	1025	290

DIMENSIONS

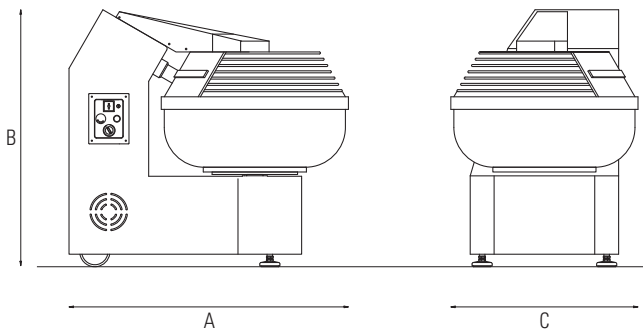

The identification data of your fork kneading machine are included in the tag attached to the back of the machine.



MODELLO MODEL	FC60DUS	IP	X1	MANUALE D'USO USER MANUAL
MATRICOLA SERIAL NUMBER	2402290	kW	1,50	
ANNO YEAR	2024	AMP.	7,10	
VOLT/ Hz./ Ph.	V.208-220/60/3	PESO Kg WEIGHT KG.	301,00	

2.2 Machine description and main elements

The table in the next page reports all the main elements of the fork kneading machine, with related description.

Please see the Parts Diagram document for this equipment.

2.3 Control Panel

The control panel is located on the side of the machine and it includes all the push button needed to its management (operation, kneading time programming, etc).

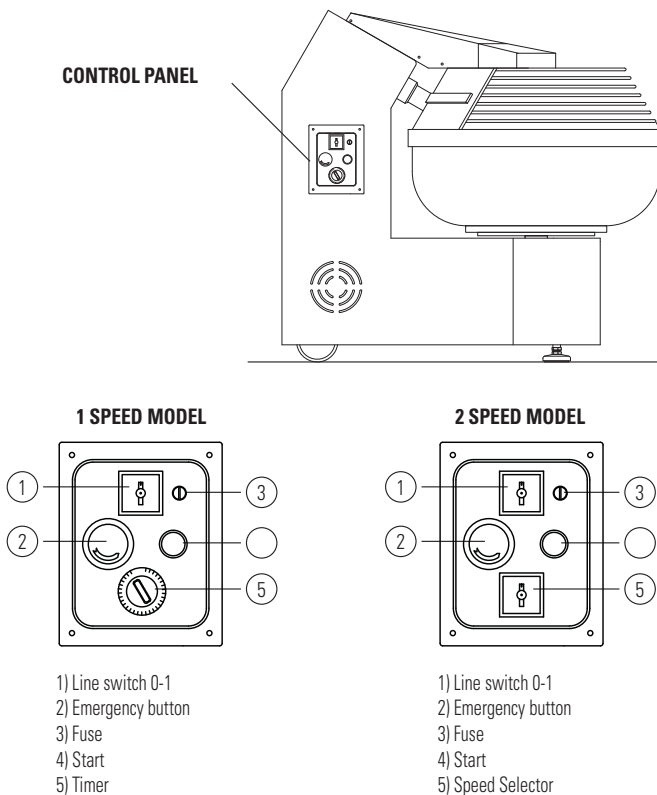

2.4 Accident Prevention Protections

Mecnosud's fork kneading machine is equipped with a series of safety devices. Under no circumstance these devices must be removed or tampered with. The manufacturer is not liable for damages for failure to comply with safety standards at work, or for tampering with or removing the safety devices from the machine. Before using the machine, make sure that the safety devices listed below are all present and fully operating. In the event of detected anomalies of operation or in absence of the safety devices, DO NOT USE the machine, and notify the manufacturer.

2.4.1. Mechanical Protections

Bowl Protection Guard

It prevents the operator from entering in contact with the fork. Lifting the fork triggers the interruption of the fork motion through the activation of the micro-switch located on the arm of the machine. In order to restart the machine it is necessary to close the cover and to press the START button.

The perforated grille under the machine and back panel protection

They prevent access to the electrical and transmission elements of the machine.

2.4.2. Electrical Protections

All the electrical components are enclosed in a box featuring an IP54 protection degree. The machine has been designed for ground connection against indirect contact hazard. The components of the control panel operate at low voltage, 24 Volts, and they are encased in housings with an IP54 protection degree. The electrical circuit is equipped with short circuits and overload protection devices. For maintenance on the electrical elements, see the wiring diagrams below. These operations must be performed by trained personnel, equipped with the necessary authorizations and only after disconnecting the machine from the line.

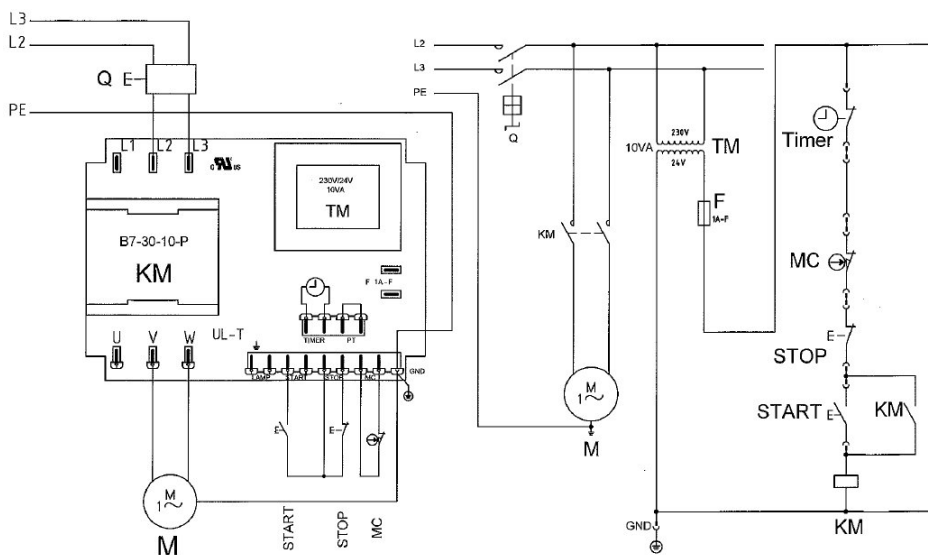

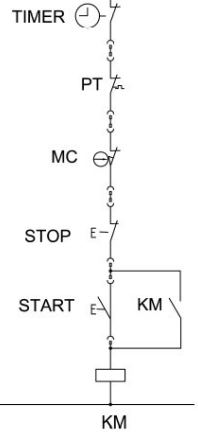
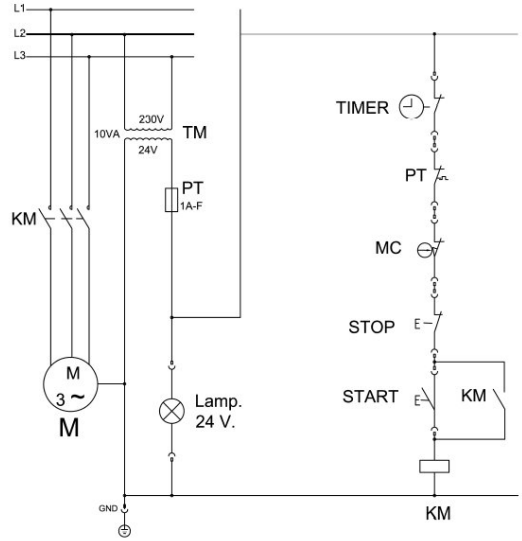
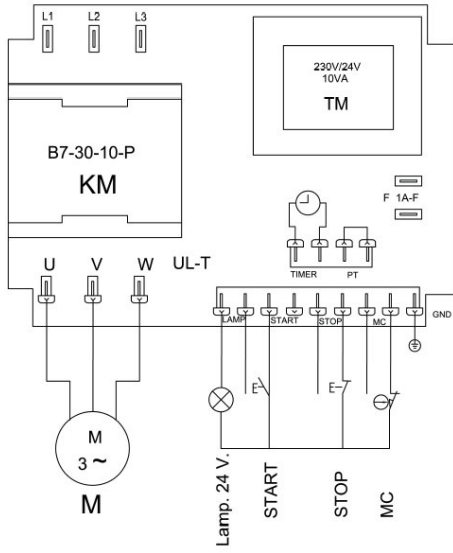

CHAPTER 3 | CLEANING AND MAINTENANCE

3.1 General Guidelines

Mecnosud fork kneading machine, due to its structural characteristics, does not require specific and frequent maintenance. However, all cleaning activities whether part of standard or extraordinary maintenance must be performed by qualified personnel and only after having disconnecting the machine from the line. For standard and extraordinary maintenance, contact your dealer or authorized service center. For maintenance and repairs, use only original spare parts.

3.2 Cleaning the Machine

Mecnosud fork kneading machine, being destined to food processing, must be kept clean to prevent growth of bacteria. It is recommended to perform a daily cleaning of all the elements that are in direct contact with the dough (fork, bowl, protection grille) and at least a weekly cleaning of the whole machine, in order to avoid accumulation of dust on the frame and all other finishing elements.

Cleaning must be performed only while the machine is stopped using only mild detergents, specific for food machines. The machine must be cleaned without removing any component. After having completed the cleaning and maintenance activities, check the proper operation of all the protection devices.

3.3. Standard Maintenance

Standard maintenance must be performed only by trained technicians. Standard maintenance consists primarily in adjusting the drive belts tension.

WARNING

The first adjustment to the machine must be carried out after the first twenty hours of operation and then at least monthly.

To adjust the belt tension, proceed as described in the following table.

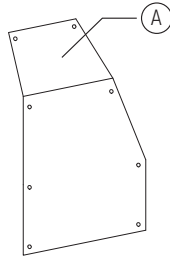
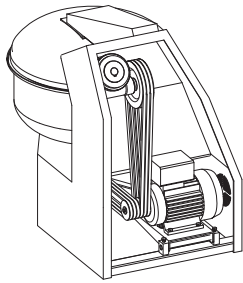

BELT ADJUSTMENT

- 1) Remove the rear cover 'A'
- 2) Loosen up the four screws 'B'
- 3) The bowl belt must be tensioned by acting on the screw 'C'
- 4) The fork belts must be tensioned by acting on the nut 'D'
- 5) Tighten up the screws 'B'
- 6) Re-assemble the rear cover

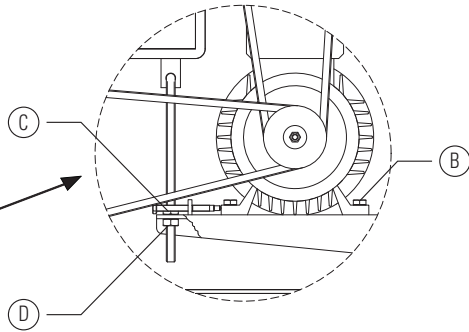
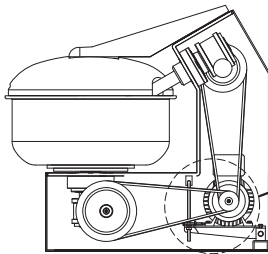

Check at least once a month that the power cord is in good conditions.

3.4 Extraordinary Maintenance

Extraordinary maintenance must be performed only by trained personnel. For these operations consult your dealer or the machine manufacturer.

3.5 Spare Parts

For repairs or replacement of worn parts on the Mecnosud fork kneading machine, use only original parts. It is possible to purchase these components from Mecnosud dealers or by contacting the manufacturer. To order spare parts, refer to the serial number of the machine and all the data on the nameplate. For the identification of the component, mention the number shown in the drawing attached to section 2.2 of this manual.

Warranty of the spare parts is one-year and only if the repair has been carried out by a technician authorized by the manufacturer.