



OPERATOR'S M A N U A L

OIL DISPOSAL SHUTTLE

MODEL ODS-300



03180002



HENNY PENNY
Engineered to Last

REGISTER WARRANTY ONLINE AT WWW.HENNYPENNY.COM

TABLE OF CONTENTS

Section	Page
Section 1. INTRODUCTION	1-1
1-1. Introduction.....	1-1
1-2. Features.....	1-1
1-3. Proper Care	1-1
1-4. Assistance	1-1
1-5. Safety	1-2
 Section 2. ASSEMBLY	 2-1
 Section 3. OPERATION.....	 3-1
 Section 4. PART INFORMATION	 4-1
4-1. Introduction.....	4-1
4-2. Genuine Parts.....	4-1
4-3. How to Order	4-1
4-4. Prices.....	4-1
4-5. Delivery.....	4-1
4-6. Warranty	4-1
4-7. Recommended Spare Parts for Distributors.....	4-1

SECTION 1. SAFETY

Where information is of particular importance or is safety related, the words NOTICE, CAUTION, or WARNING are used. Their usage is described below:



SAFETY ALERT SYMBOL is used with DANGER, WARNING, or CAUTION which indicates a personal injury type hazard.



NOTICE is used to highlight especially important information.



CAUTION used without the safety alert symbol indicates a potentially hazardous situation which, if not avoided, may result in property damage.



CAUTION used with the safety alert symbol indicates a potentially hazardous situation which, if not avoided, may result in minor or moderate injury.



WARNING indicates a potentially hazardous situation which, if not avoided, could result in death or serious injury.



DANGER INDICATES AN IMMINENTLY HAZARDOUS SITUATION WHICH, IF NOT AVOIDED, WILL RESULT IN DEATH OR SERIOUS INJURY.

SECTION 2. ASSEMBLY

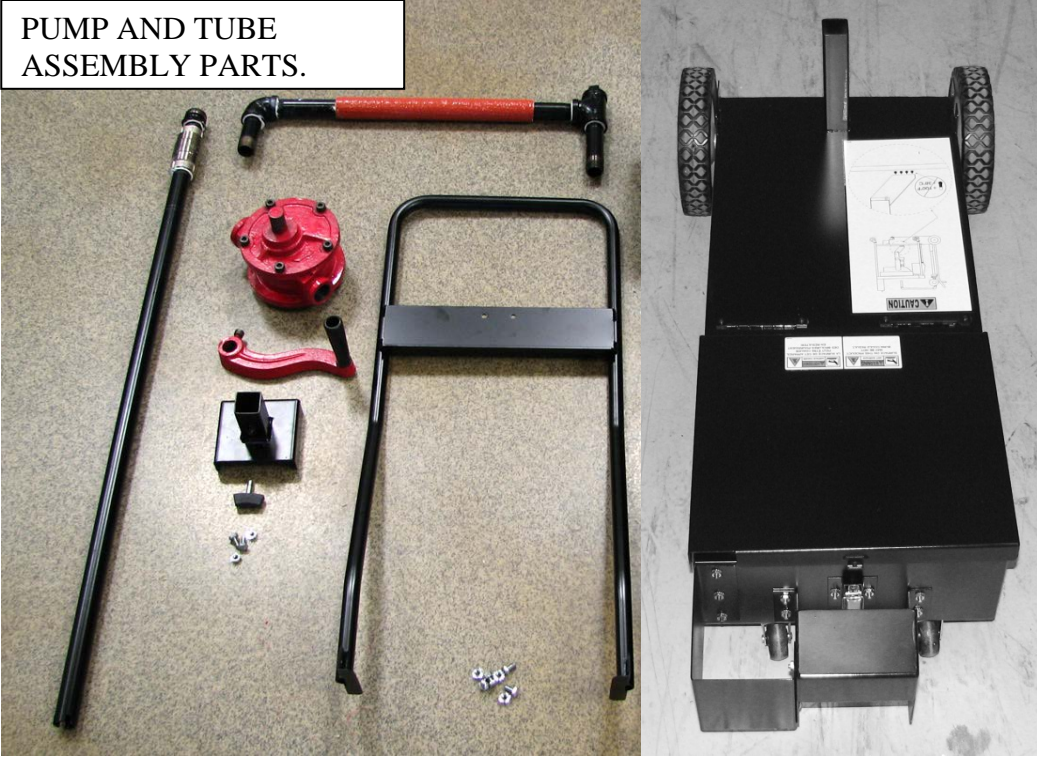

REMOVE THESE PARTS AND DISCARD, THEY ARE NOT USED.

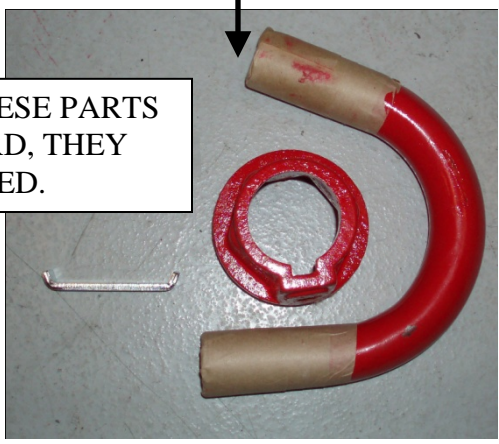

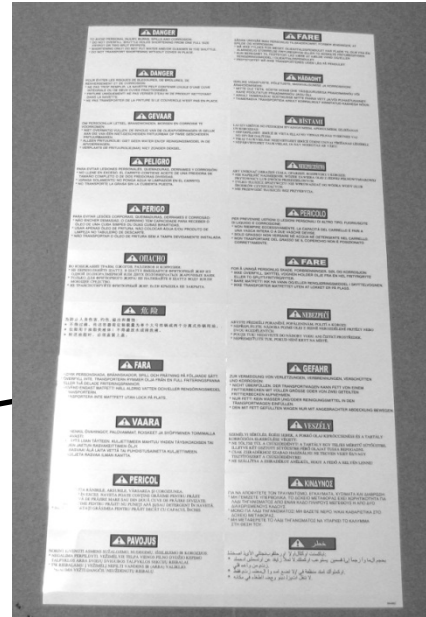
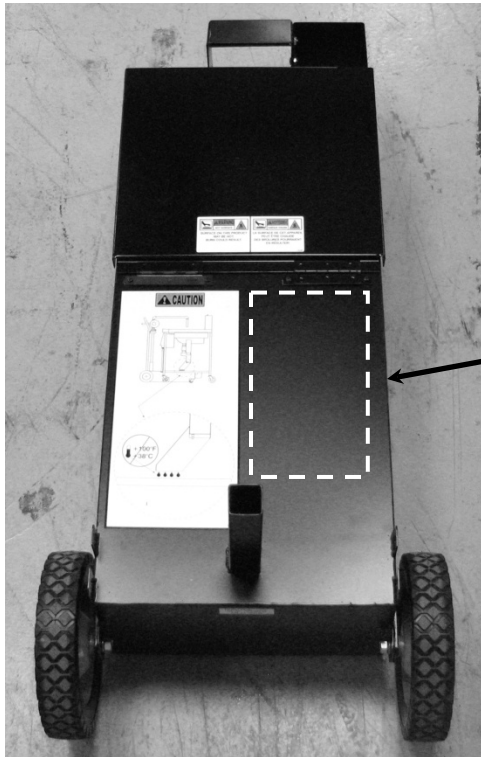

LOCATE THE SHEET OF HAZARDOUS LABELS INSIDE THE UNIT AND CHOOSE YOUR PREFERRED LANGUAGE. PLACE THAT LABEL ON THE ODS-300 COVER IN THE AREA MARKED WITH DOTTED LINES IN THE PICTURE.

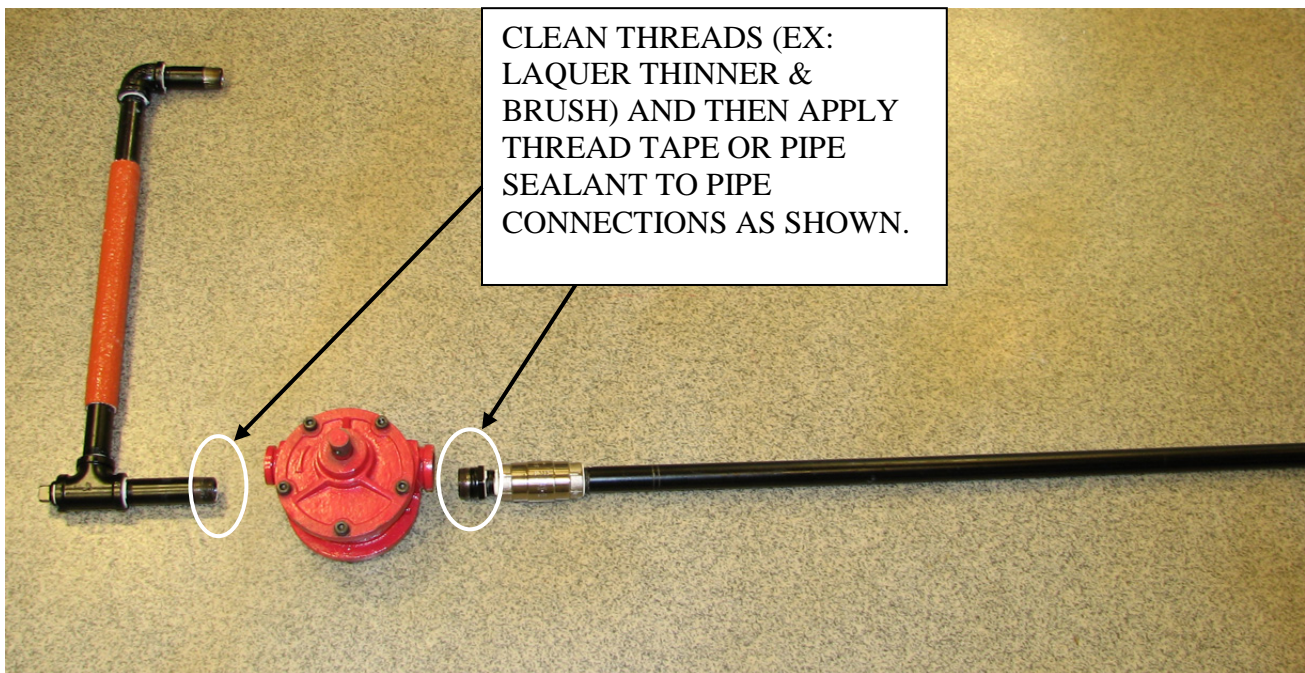

CLEAN THREADS (EX: LAQUER THINNER & BRUSH) AND THEN APPLY THREAD TAPE OR PIPE SEALANT TO PIPE CONNECTIONS AS SHOWN.



ATTACH HANDLE TO PUMP.



BOLT BRACKET TO HANDLE WITH BOLTS PROVIDED AND SLIDE PUMP AND TUBE ASSEMBLY THROUGH SQUARE TUBE AND INTO ROUND TUBE.



INSERT THUMB SCREW INTO BRACKET AND TIGHTEN TUBE IN BRACKET.

TAKE BLACK PIPE ASSEMBLY AND ATTACH TO TOP OF PUMP AS SHOWN USING THREAD TAPE. TURN UNTIL TIGHT AND LINED UP AS SHOWN BELOW.



SECTION 3. OPERATION

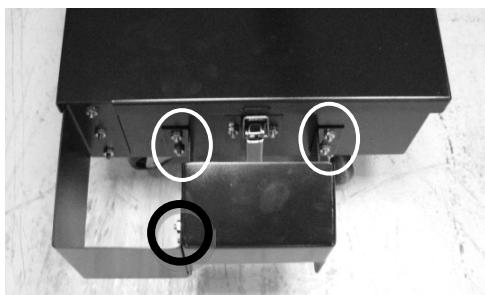





1. Release cover latch and hinge cover back on oil disposal shuttle. Make sure crumb catcher is in place.
2. Remove filter drain pan assembly from under fryer and roll oil disposal shuttle under fryer until it stops. Make sure drain aligns with opening in shuttle.



TO AVOID PERSONAL INJURY, BURNS, SPILLS, AND CORROSION:

- **DO NOT OVERFILL. SHUTTLE HOLDS OIL FROM ONE FULLSIZE FRYPOT OR TWO SPLIT FRYPOTS**
- **SHORTENING ONLY! DO NOT PUT WATER AND/OR CLEANER IN THE SHUTTLE**
- **DO NOT TRANSPORT OIL WITHOUT COVER IN PLACE**

3. Press and hold  (on either side) until display shows *FILTER MENU*, along with “1.AUTO FILTER?”.
4. Press and release  twice until display shows “3.DISPOSE”. Press  button and display shows “DISPOSE?” along with “YES NO”.
5. With oil disposal shuttle rolled into place, press & hold  button and displays shows “DISPOSING”. Oil now drains from the vat into the shuttle.



On LVE/LVG-10X fryers, if oil disposal shuttle is not properly in place, “IS DISPOSAL UNIT IN PLACE?” shows in display. Adjust center bracket on the front of shuttle as needed by loosening 6 nuts holding bracket and moving bracket up or down. Once properly adjusted, the display shows “DISPOSING”.

6. Display shows VAT EMTY, along with “YES NO”. Verify that vat is empty, and press √ button.
7. Display shows “CLN VAT COMPLETE”, along with “YES NO”. Once vat is clean, press √ button.



8. Display shows “MANUAL FILL POT”, followed by “VAT FULL”, along with “YES NO”. Fill the vat to the lower indicator line on the rear of the vat and then press √ button. Controls return to normal operation.
9. Remove the oil disposal shuttle from under fryer and replace with the filter pan assembly.



10. Replace and latch the cover and roll oil disposal shuttle to disposal container.



To avoid burns and personal injury, allow oil to cool to 100°F (38 °C) or below before transporting shuttle to the disposal area.

11. Turn thumb screw on bracket to loosen pump assembly.
12. Swivel pump assembly over disposal container and tighten thumb screw on bracket.

13. Turn pump handle rapidly (fast) in order to prime the pump and to get oil to flow through pump.

CAUTION

To avoid damage to pump,

- *only pump oil at 100°F (38°C) or below*
- *do not pump water or water-based liquids*



14. Once shuttle is empty, loosen thumb screw on bracket and swivel pump assembly back over lower unit and tighten handle.

CLEANING

15. Daily, remove the crumb catcher and take it to a sink and clean with soap and water. Clean the exterior of the shuttle with a soft cloth and soap and water. It's not necessary to clean the interior of the unit, but if desired it can be wiped down with paper towels.

CAUTION

To avoid damage to pump, do not use water or water-based liquids to clean the interior of the shuttle.

SECTION 4. PARTS INFORMATION

4-1. INTRODUCTION

This section identifies and lists the replaceable parts of the Henny Penny ODS-300, Oil Disposal Shuttle.

4-2. GENUINE PARTS

Use only genuine Henny Penny parts in your unit. Using a part of lesser quality or substitute design may result in unit damage or personal injury.

4-3. HOW TO FIND PARTS

To find items you want to order from the Parts List, proceed as follows:

1. Refer to the exploded drawing in this section to identify the part needed.
2. Use the item number from the exploded drawing to locate the corresponding part in the parts list in this section. In this list will be the Henny Penny part number and description of the part.

4-4. HOW TO ORDER PARTS

Once the part you want to order has been found in the Part List, write down the following information:

1. From the exploded drawing and Parts List (Sample)
Item Number 7
Part Number 77237
Description ASSY -COVER LVE DRAIN PAN DOLLY
2. From the data plate (Sample)
Serial Number 00100

4-5. PRICES

Your distributor has a price parts list and will be glad to inform you of the cost of your parts order.

4-6. DELIVERY

Commonly replaced items are stocked by your independent Henny Penny distributor and will be sent out when your order is received. Other parts will be ordered by the distributor from Henny Penny Corporation. Normally, these will be sent to your distributor within three working days.

4-7. WARRANTY

All replacement parts (except lamps and fuses) are covered under warranty for 90 days against manufacturing defects and workmanship. If damage occurs during shipping, notify the carrier at once so that a claim may be properly filed. Refer to the warranty in this manual for other rights and limitations.

4-8. RECOMMENDED SPARE PARTS FOR DISTRIBUTORS

Recommended replacement parts, stocked by your distributor, are indicated with √ in the parts lists. Please use care when ordering recommended parts, because all voltages and variations are marked. Distributors should order parts based upon common voltages and equipment sold in their territory.

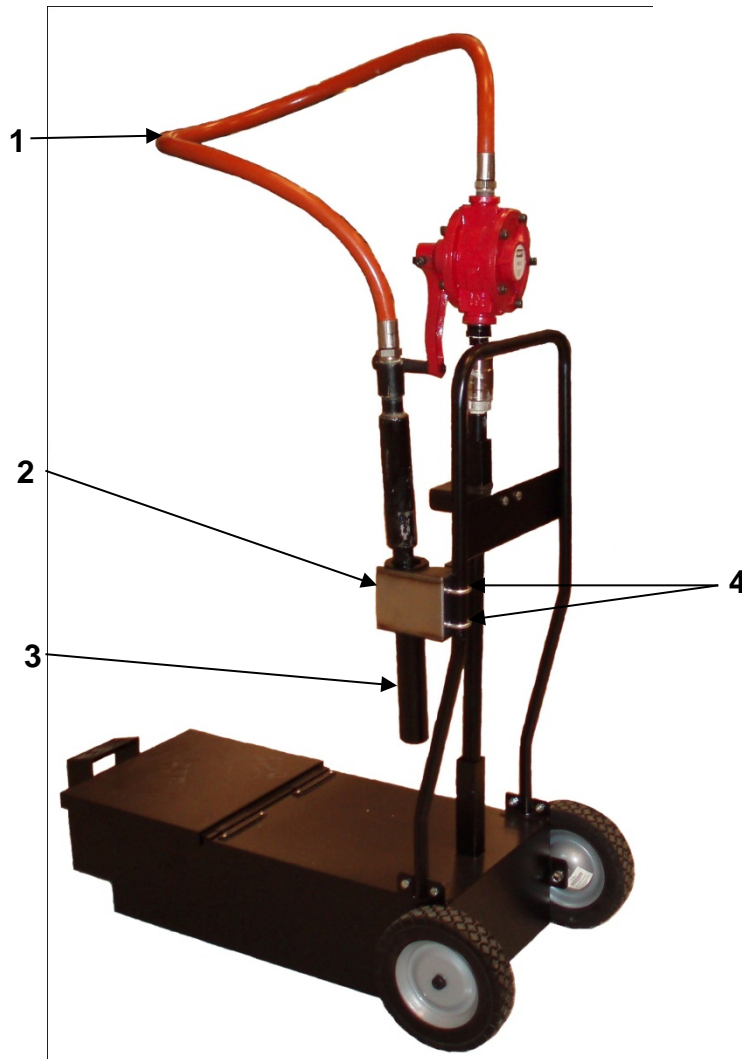

Item Number	Part Number	Description	Qty
--	03616	FILTER HOSE ACCESSORY	--
1	81066	FILTER HOSE ASSY	1
2	85135	HOLDER BRACKET	1
3	80995	FILTER HOSE HOLDER	1
4	SC06-013	U-BOLTS	2
5*	NS02-002	NUTS	4

* not shown

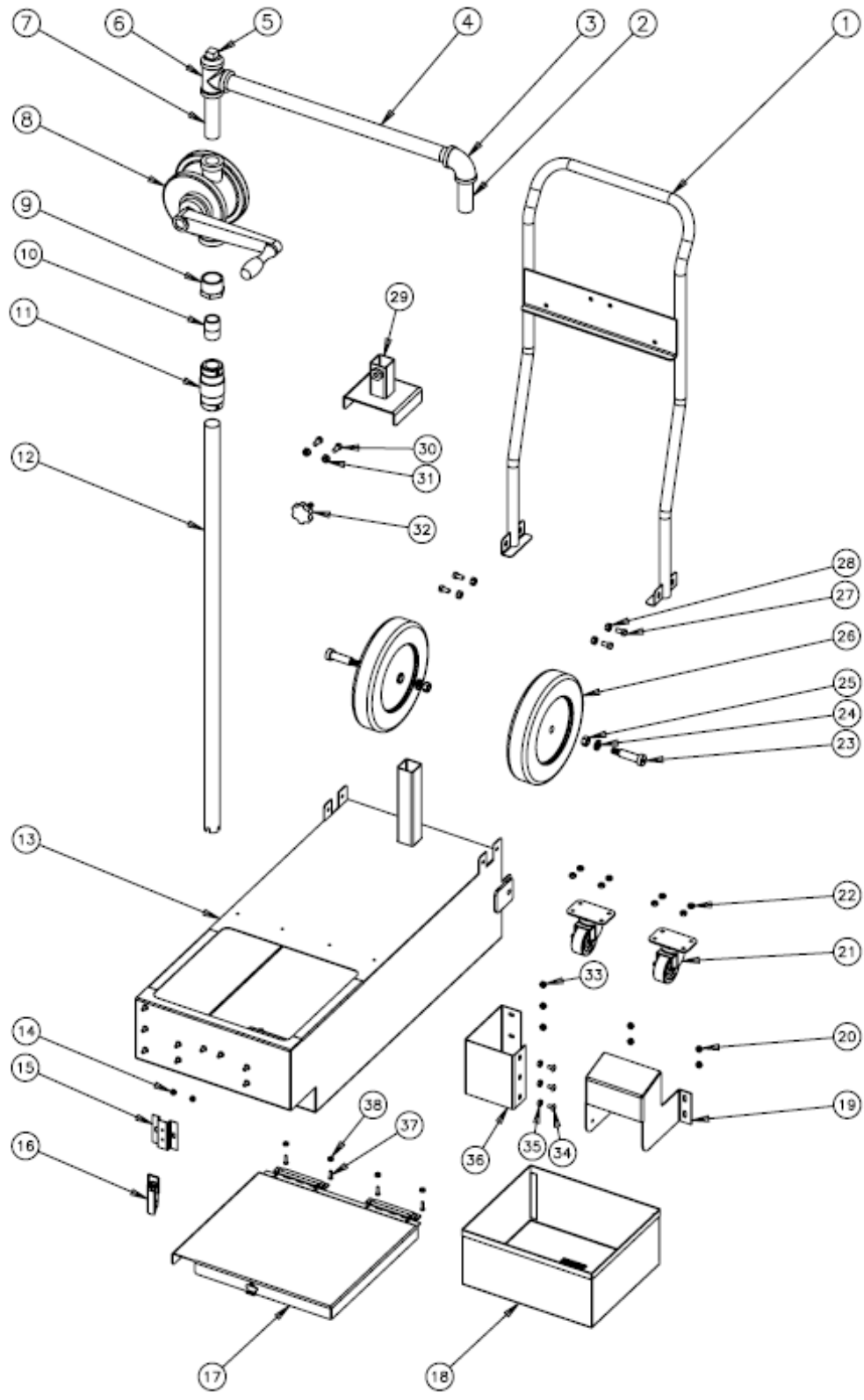

Item Number	Part Number	Description	Qty	
	1	84368	WELD ASSY-DRAIN PAN DOLLY HAND	1
	2	FP02-021	NIPPLE – ¾ NPT X 3 IN LG-BI	1
	3	FP01-098	ELBOW-3/4NPT X 90 FEMALE BI	1
	4	FP02-056	NIPPLE-3/4NPT X 18.25 INCH BI	1
	5	FP01-140	PLUG – ¾ PIPE BI	1
	6	FP01-097	TEE-3/4 NPT FEMALE PIPE BI	1
	7	FP02-033	NIPPLE-3/4NPT X 4 IN LONG BI	1
A	8	72490	PUMP-MANUAL OIL DISCARD	1
	9	FP01-227	REDUCER 1" MALE TO 3/4" FEMALE	1
	10	16282	NIPPLE 3/4 X CLOSE	1
A	11	21800	VALVE-3/4 CHECK	1
	12	84376	PIPE-BLACK 3/4	1
	13	N/A	Not orderable	N/A
	14	NS02-005	NUT HEX KEPS #6-32 C	2
	15	83994	BRKT-HINGE MOUNTING	1
A	16	MS01-532	LATCH-BREADING MACHINE DRUM	1
B	17	84001	ASSY-COVER LVE DRAIN PAN DOLLY	1
B	18	84453	WELD ASSY-CRUMB BASKET	1
B	19	84519	BRACKET-DRAIN SW ENGAGEMENT	1
	20	NS02-006	NUT – HEX – KEPS #10-24 C	4
B	21	19004	CASTER 2" SWIVEL PLATE	1
	22	NS02-006	NUT – HEX – KEPS #10-24 C	8
B	23	SC06-074	SCREW-1/2X1-1/2 SHOULDER 3/8-16	2
	24	LW01-010	LOCKWASHER – SPLIT-RING 3/8 S	2
	25	NS01-001	NUT – HEX 3/8-16	2
B	26	77815	WHEEL-8 INCH LVE	2
B	27	SC01-057	SCREW – ¼-20 x ½ HEX HD C	4
	28	NS02-002	NUT KEPS 1/4-20 C	4
	29	84481	WELD ASSY-LOCKNUT & PUMP	1
	30	SC01-057	SCREW – ¼-20 x ½ HEX HD C	2
	31	NS02-002	NUT KEPS 1/4-20 C	2
	32	SC06-076	SCREW – THUMB M8 X 25MM BLK KNOB	1
	33	NS02-006	NUT – HEX – KEPS #10-24 C	3
	34	SC01-038	SCREW #10-24 X 3/8 PH THD S	3
	35	NS02-006	NUT – HEX – KEPS #10-24 C	3
	36	88527	BRACKET-ODS DRAIN SWITCH	1
B	37	SC01-113	SCREW #6-32 X 9/16 PH PHD BLAK	4
B	38	NS02-005	NUT HEX KEPS #6-32 C	4



Henny Penny Corporation
P.O.Box 60
Eaton, OH 45320

1-937-456-8400
1-937-456-8402 Fax

Toll free in USA
1-800-417-8417
1-800-417-8434 Fax

www.hennypenny.com