



Project \_\_\_\_\_  
 AIA # \_\_\_\_\_ SIS # \_\_\_\_\_  
 Item # \_\_\_\_\_ Quantity \_\_\_\_\_ C.S.I. Section 114000



# FT1000e BASE STEAM WITH BLOWER DRYER

## Flight-Type Dishwashing Machine

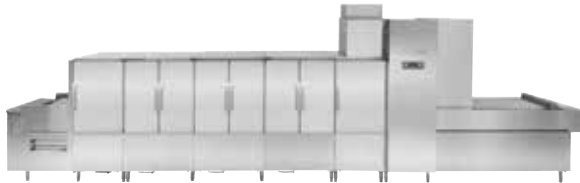

Advansys model shown



Complies with EPA Reduction of Lead in Drinking Water Act 2014

Meets requirements of ASSE Standard No. 1004

### SPECIFIER STATEMENT

The specified machine shall be a Hobart base flight type dish machine with blower dryer, 58 gallons of final rinse consumption per hour, with dual rinse, hinged & insulated doors, 30" wide conveyor belt, capless wash arms, microprocessor controls and blower dryer.

### STANDARD FEATURES

- + Pumped rinse system (pressure gauge not required)
- + Water usage 58 gph
- + Digital controls with machine diagnostics
- + Low temperature alert
- + Hinged insulated cabinet-style doors
- + 31" access on prewash, power wash and power rinse chambers; 20" access on dual rinse and ASR chambers
- + Start and stop switches at both ends
- + Doors open indicator
- + Drains open indicator
- + Door interlocks
- + 3½ H.P. prewash, power wash, and power rinse pump motors, all TEFC
- + Capless wash arms
- + Easy to remove stainless steel scrap pans and baskets
- + 30" wide conveyor belt
- + Dual rinse
- + Front and rear panels
- + Variable speed conveyor
- + Steam booster heater
- + Configurable drain to load or unload
- + Steam blower dryer

### OPTIONS & ACCESSORIES (Available at extra cost)

- Multiple conveyor options
- Factory mounted circuit breakers
- 6" higher than standard chamber
- Flanged feet (field installed)
- Water hammer arrestor/PRV (field installed)
- Drain water tempering kit (field installed)
- WS-80 water softener (field installed)
- Insulated split, vertical slide-up doors
- Correctional packages available – contact Hobart for more information
- Casino packages

FT SERIES – FT1000e BASE STEAM WITH BLOWER DRYER

Approved by \_\_\_\_\_ Date \_\_\_\_\_ Approved by \_\_\_\_\_ Date \_\_\_\_\_



# FT1000e BASE STEAM WITH BLOWER DRYER

## Flight-Type Dishwashing Machine

(Left to Right)

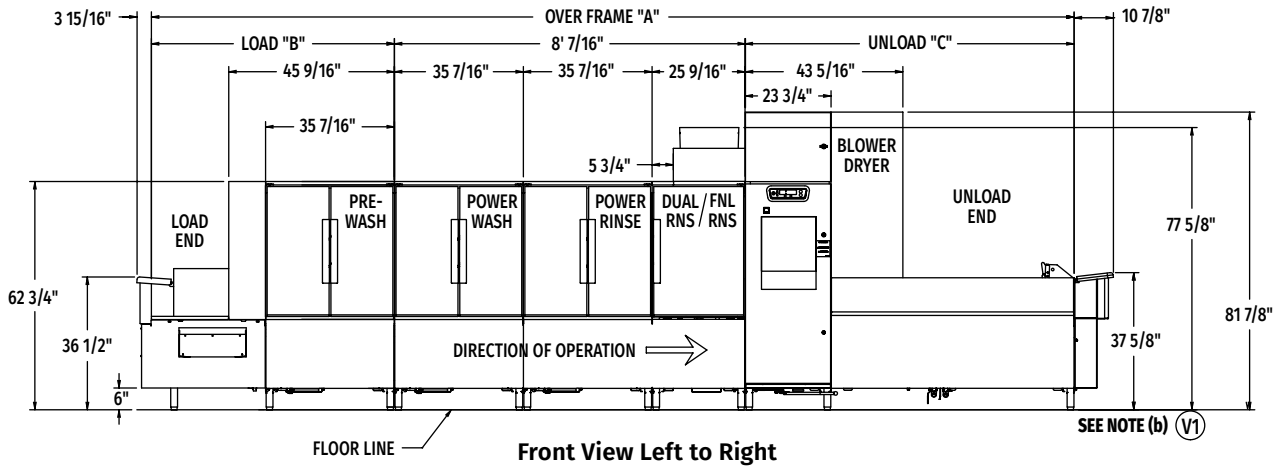
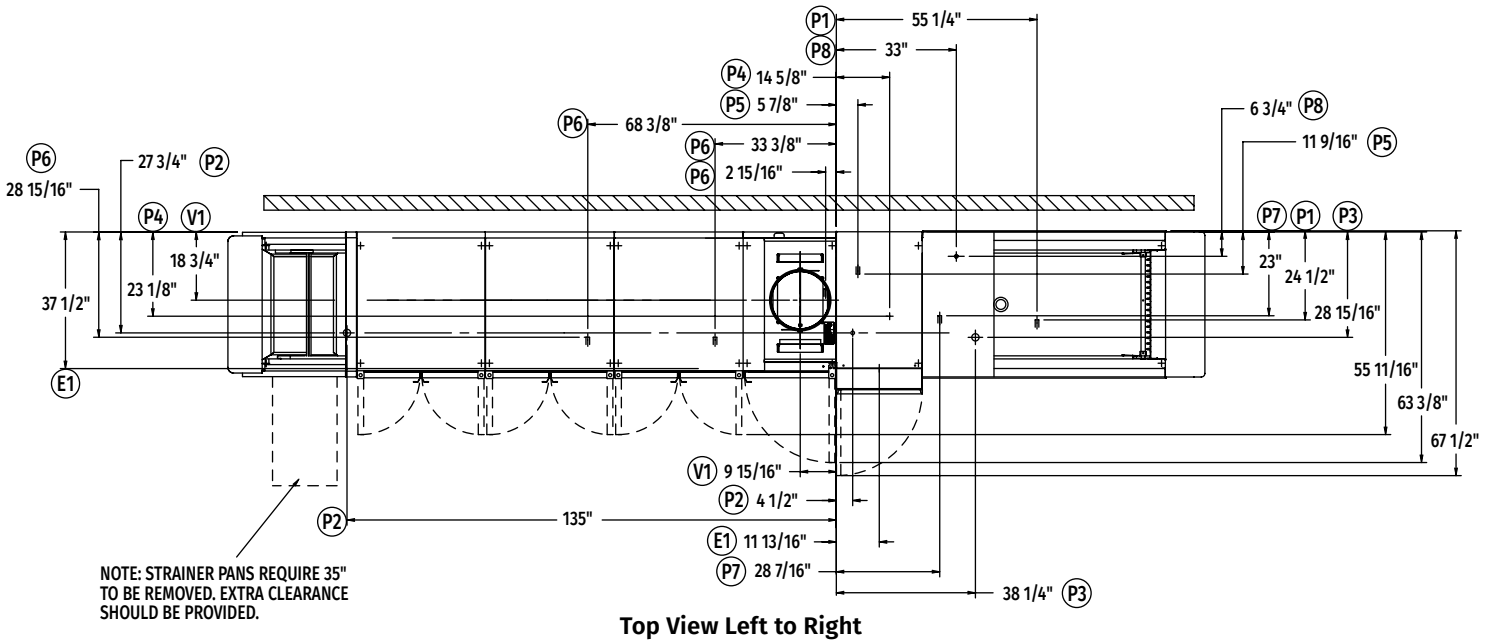

**Note:** Control box electrical connections – see page 5.

MODEL NO.	"A"	"B"	"C"
FT1021e (5.5'-8'-7.5')	21' 1-7/8"	5' 6-15/16"	7' 6-1/2"
FT1022e (6.5'-8'-7.5')	22' 1-5/8"	6' 6-11/16"	7' 6-1/2"
FT1023e (7.5'-8'-7.5')	23' 1-15/32"	7' 6-17/32"	7' 6-1/2"
FT1023e (5.5'-8'-9')	22' 9-5/8"	5' 6-15/16"	9' 2-1/4"
FT1024e (6.5'-8'-9')	23' 9-3/8"	6' 6-11/16"	9' 2-1/4"
FT1025e (7.5'-8'-9')	24' 9-7/32"	7' 6-17/32"	9' 2-1/4"
FT1025e (5.5'-8'-11')	24' 9-1/4"	5' 6-15/16"	11' 1-7/8"
FT1026e (6.5'-8'-11')	25' 9"	6' 6-11/16"	11' 1-7/8"
FT1027e (7.5'-8'-11')	26' 8-27/32"	7' 6-17/32"	11' 1-7/8"
FT1028e (5.5'-8'-15')	28' 4-9/16"	5' 6-15/16"	14' 9-3/16"
FT1029e (6.5'-8'-15')	29' 4-5/16"	6' 6-11/16"	14' 9-3/16"
FT1030e (7.5'-8'-15')	30' 4-5/32"	7' 6-17/32"	14' 9-3/16"
FT1030e (5.5'-8'-17')	30' 4-1/8"	5' 6-15/16"	16' 8-3/4"
FT1031e (6.5'-8'-17')	31' 3-7/8"	6' 6-11/16"	16' 8-3/4"
FT1032e (7.5'-8'-17')	32' 3-23/32"	7' 6-17/32"	16' 8-3/4"

**Note:** Overall length of machine is Dimension "A" + 14'-13/16"

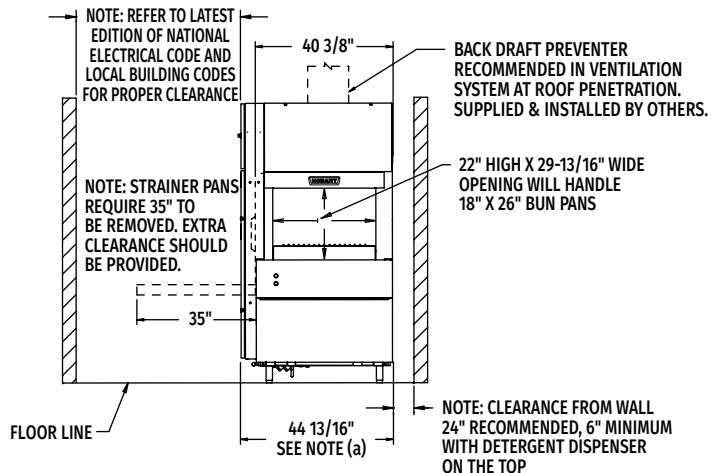

MODEL:  
FT1000e BASE  
W/BLOWER DRYER  
STEAM  
L-R OPERATION  
00-562365  
REV B



# FT1000e BASE STEAM WITH BLOWER DRYER

## Flight-Type Dishwashing Machine

(Right to Left)

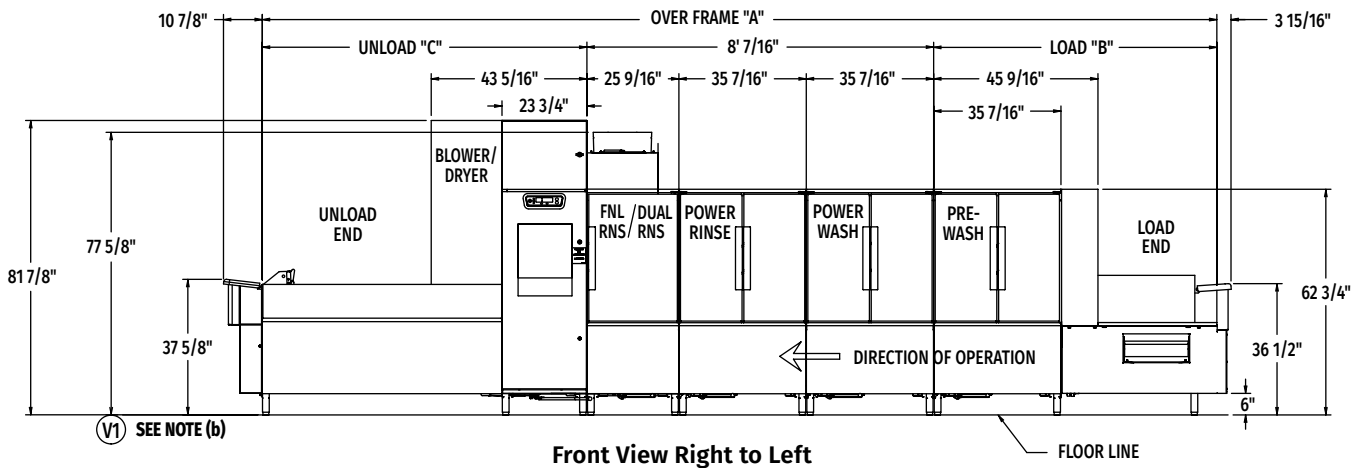
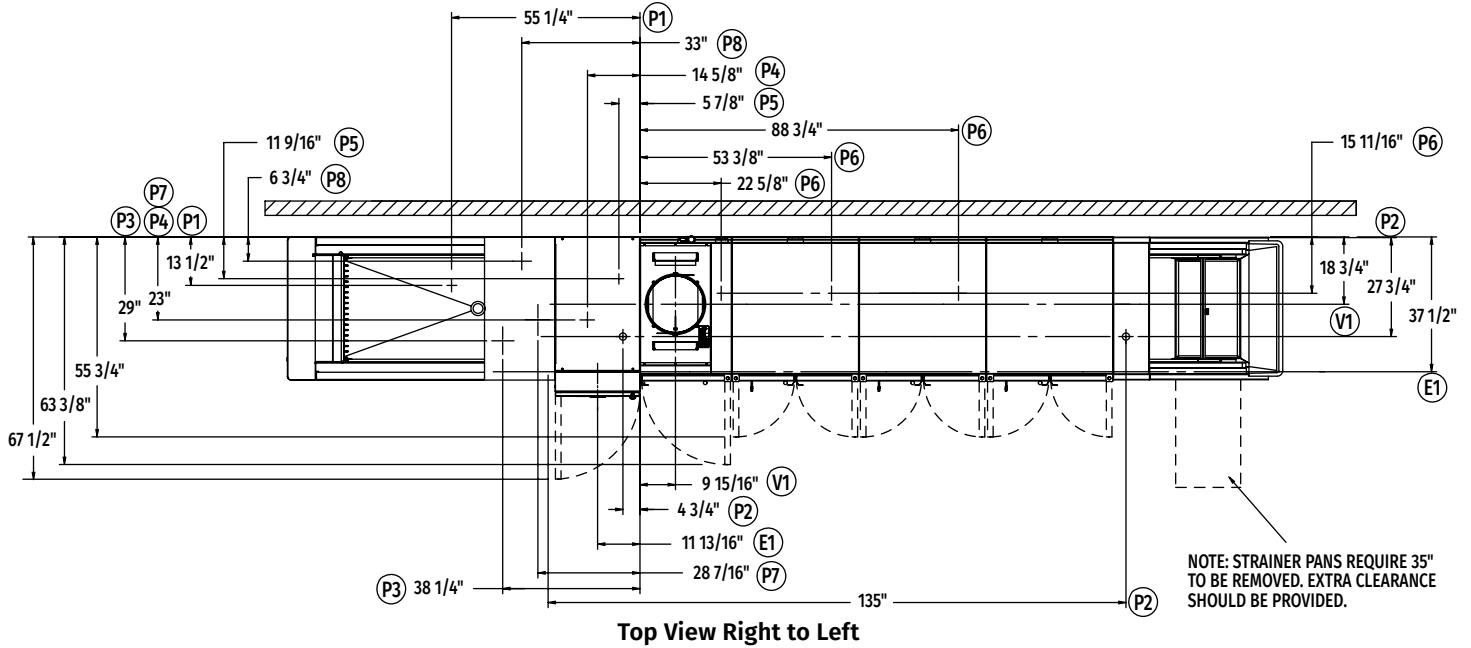

Note: Control box electrical connections – see page 5.

MODEL NO.	"A"	"B"	"C"
FT1021e (5.5'-8'-7.5')	21' 1-7/8"	5' 6-15/16"	7' 6-1/2"
FT1022e (6.5'-8'-7.5')	22' 1-5/8"	6' 6-11/16"	7' 6-1/2"
FT1023e (7.5'-8'-7.5')	23' 1-15/32"	7' 6-17/32"	7' 6-1/2"
FT1023e (5.5'-8'-9')	22' 9-5/8"	5' 6-15/16"	9' 2-1/4"
FT1024e (6.5'-8'-9')	23' 9-3/8"	6' 6-11/16"	9' 2-1/4"
FT1025e (7.5'-8'-9')	24' 9-7/32"	7' 6-17/32"	9' 2-1/4"
FT1025e (5.5'-8'-11')	24' 9-1/4"	5' 6-15/16"	11' 1-7/8"
FT1026e (6.5'-8'-11')	25' 9"	6' 6-11/16"	11' 1-7/8"
FT1027e (7.5'-8'-11')	26' 8-27/32"	7' 6-17/32"	11' 1-7/8"
FT1028e (5.5'-8'-15')	28' 4-9/16"	5' 6-15/16"	14' 9-3/16"
FT1029e (6.5'-8'-15')	29' 4-5/16"	6' 6-11/16"	14' 9-3/16"
FT1030e (7.5'-8'-15')	30' 4-5/32"	7' 6-17/32"	14' 9-3/16"
FT1030e (5.5'-8'-17')	30' 4-1/8"	5' 6-15/16"	16' 8-3/4"
FT1031e (6.5'-8'-17')	31' 3-7/8"	6' 6-11/16"	16' 8-3/4"
FT1032e (7.5'-8'-17')	32' 3-23/32"	7' 6-17/32"	16' 8-3/4"

Note: Overall length of machine is Dimension "A" + 14'-13/16"

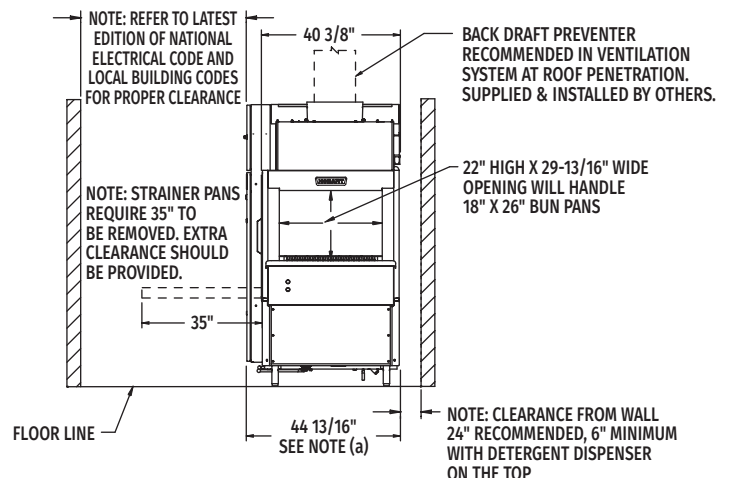

**Back/Unload End**

MODEL:  
FT1000e BASE  
W/ BLOWER DRYER  
STEAM  
R-L OPERATION  
00-562364  
REV B



# FT1000e BASE STEAM WITH BLOWER DRYER

## Flight-Type Dishwashing Machine

(Left to Right)

### LEGEND

Electrical Connections	
E1	Electric connection for 1TB with or without circuit breakers. 79-1/8" AFF.
Plumbing Connections	
P1	Common hot water connection (automatic fill) 110° F water minimum, 1" FPT, 5-1/2" AFF.
P2	Drain connection: Default location is drain to unload. May be drained to either end of unit. 2" FPT, 7" AFF.
P3	Common steam connection (tank heat, steam booster & blower dryer). 1-1/2" FPT, 7" AFF (12-45 PSI flowing pressure).
P4	Steam relief valve (when steam booster option is specified) 1" FPT, must be piped to open drain receiver in the floor. 16-15/16" AFF.
P5	Hot water relief valve (when steam booster option is specified) 3/4" FPT, must be piped to open drain receiver in the floor. 15-9/16" AFF.
P6	Condensate return, gravity connection (tank heat), bucket type traps furnished, 3 connections. 3/4" FPT, 11" AFF.
P7	Condensate return, gravity connection (when steam booster option is specified), bucket type trap furnished. 3/4" FPT, 4-3/4" AFF.
P8	Condensate return, gravity connection (steam blower dryer) bucket type trap furnished. 3/4" FPT, 13" AFF.
Ventilation Connections	
V1	Customers' vent connection. Must fit inside 16" diameter vent stack providing 750 CFM exhaust at machine connection @ .75" water column (standard air conditions). Backdraft damper is RECOMMENDED ON ALL BAS models. Supplied and installed by others. 77-5/8" AFF.

**WARNING:** Plumbing and electrical connections should be made by qualified personnel who will observe all the applicable plumbing, sanitary, safety codes and National Electrical Code.

#### General Notes:

(a) The control box is attached to the center section and is rotated 90 degrees for shipping.

AFF = Above Finished Floor

All dimensions taken from the floor line may increase 3-1/4" with leg adjustment.

For convenience when cleaning, customer should install water tap near machine with 30 ft. of heavy duty hose with squeeze valve.

This drawing is supplied as a reference for connection information only. It will not be utilized for manufacturing of unit.

#### Electrical Notes:

Service wire temperature rating: 90°C minimum.

Detergent and rinse aid feeder service connections standard on all FT1000e models at machine line voltage.

Dishmachine not provided with internal GFCI protection.

#### Plumbing Notes:

Recommended building flowing hot water pressure to the dishwasher is 30-35 PSI.

Water hammer arrestor (meeting ASSE-1010 standard or equivalent) to be supplied (by others) in hot and cold supply lines at service connection.

If steam pressure is less than 12 psi flowing pressure at the dishwasher, contact sales engineering.

#### Ventilation Notes:

(b) The vent stack and its enclosure can be temporarily removed from the energy recovery unit to yield 81-7/8" clearance for doorways.

Room ventilation is required to handle machine's latent & sensible heat.

Vent fan control standard on all FT1000e models.

#### Water Quality Required:

Total water hardness < 3 grains per gallon.

Total suspended solids (TSS) < 10 microns.

Heat Gain to Space (BTU/Hr.)	
Latent	Sensible
93,700	40,200



# FT1000e BASE STEAM WITH BLOWER DRYER

## Flight-Type Dishwashing Machine

(Right to Left)

### SERVICE CONNECTIONS WITH AND WITHOUT CIRCUIT BREAKERS (SINGLE POINT ELECTRICAL CONNECTION)

Motors & Controls (1TB) (1) Service Connection as Shown Below				
E1	Voltage	Rated Amps	Minimum Supply Circuit Ampacity	Maximum Protective Device
	208-240/60/3	41.4	60	60
	480/60/3	25.2	35	35
	600/60/3	19.6	25	25

FT1000 Advansys Water Treatment System	
Model	Description
WS-80	Water Softener
<b>Available through Hobart Service only</b>	
PF-10-EHT	Hi-Temp Filter Housing
SD-510HT	Sediment Filter Cartridge

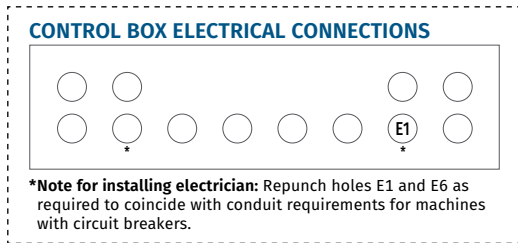

**Detail "A-A"**  
(not to scale)

### SPECIFICATIONS

#### Capacities

Conveyor Speed (feet per minute)	4.0 - 8.5
Dishes per Hour	14,316
Pre-Wash Tank (U.S. gallons)	40
Wash Tank (U.S. gallons)	40
Rinse Tank (U.S. gallons)	40
Dual Rinse Tank (U.S. gallons)	7.2

#### Motor Horsepower

Pre-Wash Tank	3½
Wash Tank	3½
Rinse Tank	3½
Dual Rinse Tank	¾
Final Rinse	½
Conveyor	¾
Blower Dryer	2

#### Water Consumption

U.S. Gallons per Hour (maximum use)	58
U.S. Gallons per Minute	0.97

#### Steam Consumption – Tank Heat

Pounds per Hour (maximum)	215
Regulated – based on 12 to 45 PSI steam at the machine. (150°F wash minimum – 160°F rinse minimum – 160°F dual rinse minimum)	

#### Steam Consumption – Blower Dryer

Pounds per Hour (maximum)	52
---------------------------	----

#### Steam Consumption – Booster Heater

Pounds per Hour (maximum)	47
If used on 20 PSI steam, 110°F incoming water raised to 185°F (75°F rise) (180°F final rinse minimum)	

**Shipping Weight (approximate)** . . . Varies by individual model  
(Consult your Hobart representative)

**Crated Dimensions** . . . . . Varies by individual model  
(Consult your Hobart representative)

## CONVEYOR TYPE OPTIONS

All conveyors provided with standard polypropylene material. Optional stainless steel conveyors available by request. Please contact your sales representative for stainless steel conveyor options.

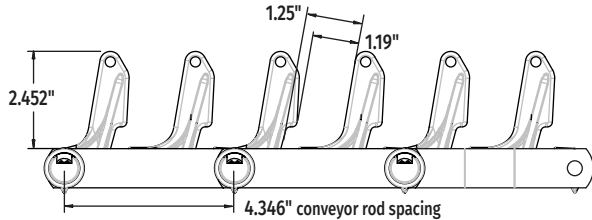

### STANDARD

Standard Conveyor designed for General Ware including tableware (Plates/Bowls), most serving trays (lip height less than 1 $\frac{1}{2}$ "") as well as prep-ware (Hotel & Sheet Pans).

- Optional cross-rods every 4th row available for additional support of heavier ware (oversized ware/mixing bowls) as well as to promote warewashing drainage at optimal angle (hotel pans).

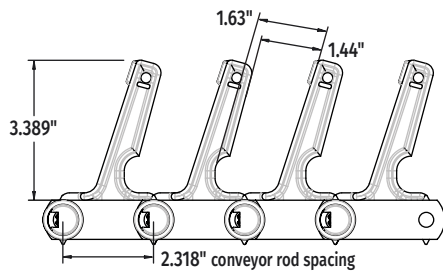

### TYPE A

Optional Conveyor designed exclusively with our Healthcare segments in mind. In addition to accommodating General Ware, the Type A conveyor has a tighter conveyor rod spacing which provides increased conveyor density for added strength, as well as additional finger height and spacing to support most insulated dome bases and lids.

- Optional cross-rods every 4th row available for additional support of heavier ware (oversized ware/mixing bowls) as well as to promote warewashing drainage at optimal angle (hotel pans).

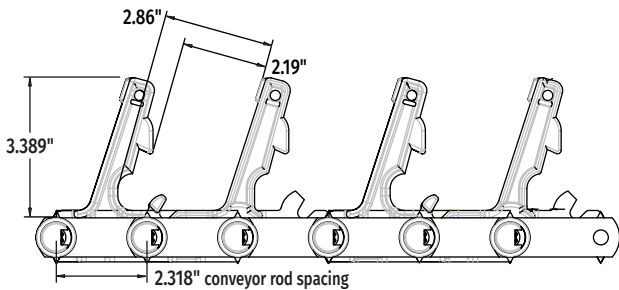

### POSITION 1

Optional Conveyor designed for customers using insulated compartmentalized trays, as well as thicker insulated dome bases and lids. In addition to accommodating General Ware, the Position 1 conveyor provides even greater spacing between fingers, as well as a pronounced  $\frac{3}{8}$ " "nose" to secure compartmentalized trays in place.

- Optional cross-rods every 4th row available for additional support of heavier ware (oversized ware/mixing bowls) as well as to promote warewashing drainage at optimal angle (hotel pans). Cross-rods can also be used to create stable support for some compartmentalized trays to orient upright through dishmachine.

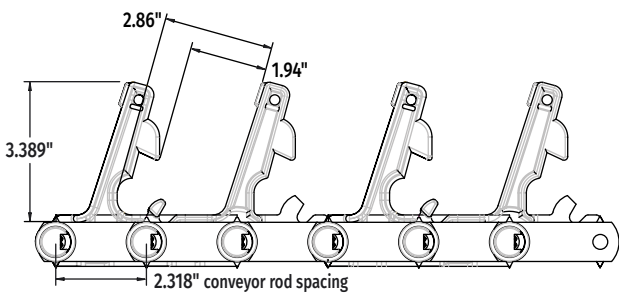

### POSITION 2

Optional Conveyor designed for customers using insulated compartmentalized trays, as well as thicker insulated dome bases and lids. In addition to accommodating General Ware, the Position 2 conveyor provides additional spacing between fingers, as well as a pronounced  $\frac{5}{8}$ " "nose" to secure compartment trays in place.

- Optional cross-rods every 4th row available for additional support of heavier ware (oversized ware/mixing bowls) as well as to promote warewashing drainage at optimal angle (hotel pans). Cross-rods also create stable support for compartmentalized trays to orient upright through dishmachine.

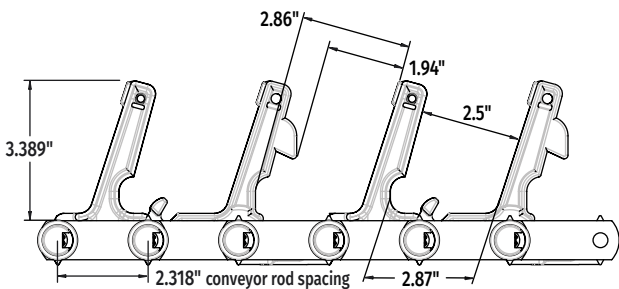

### TIVOLI

Optional Conveyor designed exclusively with our Correctional segments in mind. In addition to accommodating General Ware, the Tivoli conveyor provides our widest spacing between fingers as well as a  $\frac{3}{8}$ " "nose" to support the largest insulated compartmentalized trays, commonly used in correctional settings. The Tivoli conveyor comes standard with cross-rods every 3rd row for additional support of heavier ware (oversized ware/mixing bowls) as well as to promote warewashing drainage at optimal angle (hotel pans). Cross-rods also create stable support for compartmentalized trays to orient upright through dishmachine.

As continued product improvement is a policy of Hobart, specifications are subject to change without notice.