

ELECTRICAL

MODELS	VOLTS	WATTS	AMPS	PHASE	FIELD WIRING GAUGE	TEMP. RATING
HFW-43S, DS	208	1240	6.0	SINGLE	12 AWG CU	75°C
HFW-43S, DS	240	1650	6.0	SINGLE	12 AWG CU	75°C

CUTOUT DETAILS

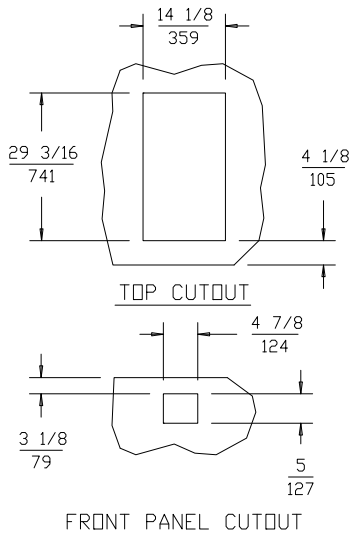

PRODUCT DIMENSIONS

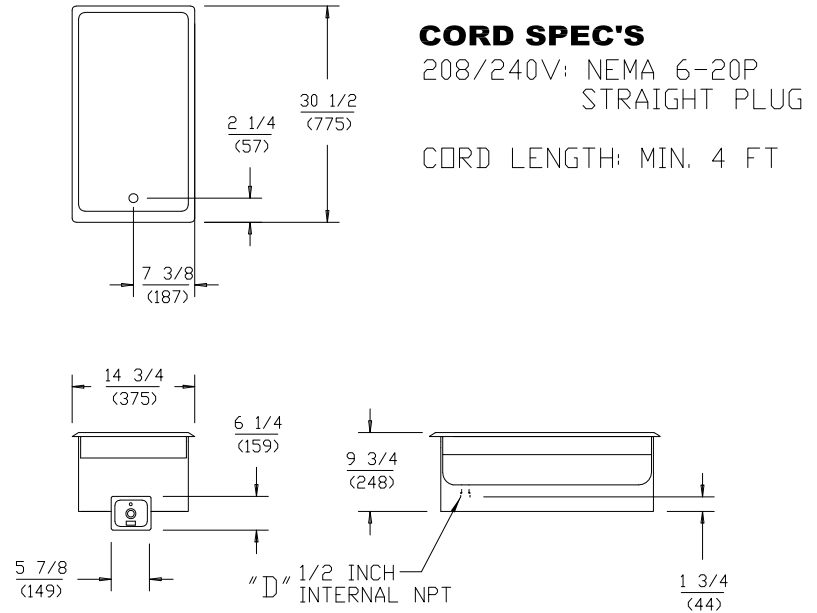

CLEARANCES

MINIMUM CLEARANCE REQUIRED UNIT TO THE NEAREST SURFACE			
BACK	SIDE	BOTTOM	FRONT
1 (25)	1 (25)	6 3/4 (171)	4 1/8 (105)

INSTALLATION INSTRUCTIONS

INSTALLER MUST MEET CONDITIONS OF ACCEPTABILITY OUTLINED BELOW UPON INSTALLATION:

1. Required Installation Clearances:
 Wooden and Metal Installation: DO NOT install closer than 4 1/8 inches to front wall, 1 inch to back and side walls, and 6 3/4 inches to a surface below the unit. If the control box is located below the unit, the front clearance may be 1 inch.

2. Unit shall be accessible for servicing from the bottom.

3. If storage is to be used underneath the unit, it is recommended that a baffle be placed 8 1/2 inches below the unit to avoid contact with elevated temperatures.

TO FABRICATE:

- Layout "cutout" dimensions on countertop and front apron.
- Layout and fabricate control panel holes in counter apron using the control box as a template.
- Cut out holes. (note: "stiffening" around perimeter of "countertop cutout" not normally required).
- Unit shall be accessible for servicing from the bottom.

TO INSTALL:

IMPORTANT - DO NOT disconnect "lead wires" from the Master Control Panel when making installation.

- Tilt and pass Control Panel and electrical box through the countertop cutout, then through the apron cutout. Lower modular section into countertop cutout and position. RECOMMENDATION: Before final seating of modular section to countertop, apply a bead of silicone adhesive/sealant to underside of gray gasket material supplied on the mounting flange.
- From underneath, insert screwdriver into "slots" in E-Z LOCK frame and twist "ears" outward (clockwise) as required to secure flange tightly to countertop.
- Mount Control Box to apron cutout as shown in drawing.

4. Mount Control Panel onto electrical box using the screws supplied.

TO PLUMB:

- Warmers with a 'D' suffix are supplied with individual 1/2" female N.P.T. drains.
- Connect to suitable drain line.

TO WIRE:

- Final connection is accomplished by bringing proper power supply leads (see 'wiring requirements' label) through conduit knockout to wire leads supplied within the Master Control Panel. Check nameplates for voltage and phase.
- Do not connect to a circuit operating at more than 150 volts to ground. (240 volt models only).

NOTE: INSTALLATION MUST MEET LOCAL PLUMBING AND ELECTRICAL CODES.

