

# ELECTRICAL

# INSTALLATION INSTRUCTIONS BUILT-IN MODULAR WARMERS

HFW-4S

MODELS	VOLTS	WATTS	AMPS PER LINE 3 PHASE			FIELD WIRING GAUGE	TEMP. RATING
			L1	L2	L3	3 PHASE	
HFW-4S	208	3600	11.2	11.2	7.5	12	75°C
HFW-4S	240	4800	13.0	13.0	8.7	12	75°C
HFW-4DS	208	3600	11.2	11.2	7.5	12	75°C
HFW-4DS	240	4800	13.0	13.0	8.7	12	75°C
HFW-4DTS	208	4960	14.5	14.5	9.8	12	75°C
HFW-4DTS	240	6600	17.8	17.8	11.3	12	75°C

## CUTOUT DETAILS

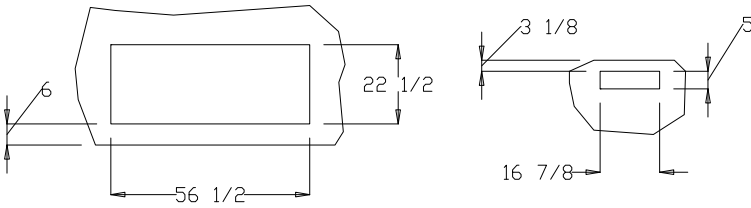

TOP CUTOUT

FRONT PANEL CUTOUT

## CLEARANCES

MINIMUM CLEARANCE REQUIRED FROM UNITS TO THE NEAREST SURFACE

BACK	SIDE	BOTTOM	FRONT
$\frac{1}{(25)}$	$\frac{1}{(25)}$	$\frac{6 \ 3/4}{(171)}$	$\frac{6}{(152)}$

## INSTALLATION INSTRUCTIONS

INSTALLER MUST MEET CONDITIONS OF ACCEPTABILITY OUTLINED BELOW UPON INSTALLATION:

- Required Installation Clearances:  
Wooden and Metal Installation: DO NOT install closer than 6 inches to front wall, 1 inch to back and side walls, and 6 3/4 inches to a surface below the unit.
- Unit shall be accessible for servicing from the bottom.
- If storage is to be used underneath the unit, it is recommended that a baffle be placed 8 1/2 inches below the unit to avoid contact with elevated temperatures.

### TO FABRICATE:

- Layout "cutout" dimensions on countertop and front apron.
- Layout and fabricate control panel holes in counter apron using the control box as a template.
- Cut out holes. (note: "stiffening" around perimeter of "countertop cutout" is not normally required).
- Unit shall be accessible for servicing from the bottom.

### TO INSTALL:

- IMPORTANT - DO NOT disconnect "lead wires" from the Master Control Panel when making installation.
- Tilt and pass Control Panel and electrical box through countertop cutout, then through apron cutout. Lower modular section into countertop cutout and position.  
RECOMMENDATION: Before final seating of modular section to countertop, apply a bead of silicone adhesive/sealant to underside of gray gasket material supplied on mounting flange.
  - From underneath, insert screwdriver into "slots" in E-Z LOCK frame and twist "ears" outward (clockwise) as required to secure flange tightly to countertop.
  - Mount Control Box to apron cutout as shown in drawing.

## PRODUCT DIMENSIONS

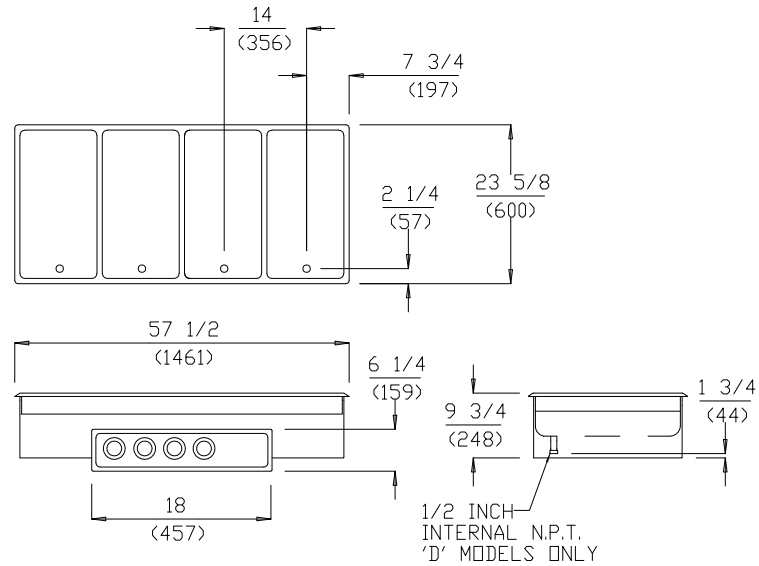

- Mount Control Panel onto electrical box using screws supplied.

### TO PLUMB:

- A drain manifold complete with valve is supplied on all Model "D" units. Location of valve handle is at the discretion of the fabricator. Install and tighten pipe plug in one end of the manifold.
- Warmers with 'D' suffix are supplied with individual 1/2" female N.P.T. drains.
- Connect 1" drain connection to suitable drain line.

### TO WIRE:

- Final connection is accomplished by bringing proper power supply leads (see 'wiring requirements' label) through conduit knockout to terminal block supplied within the Master Control Panel. Check nameplates for voltage and phase.
- Do not connect to a circuit operating at more than 150 volts to ground.

NOTE: INSTALLATION MUST MEET LOCAL PLUMBING AND ELECTRICAL CODES.

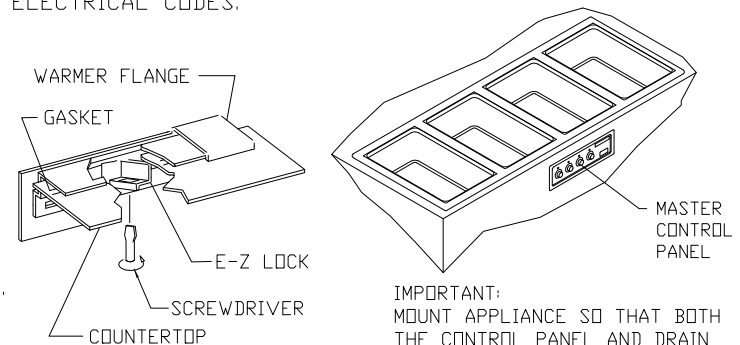

IMPORTANT:  
MOUNT APPLIANCE SO THAT BOTH THE CONTROL PANEL AND DRAIN MANIFOLD ARE LOCATED TO THE FRONT OF THE FIXTURE.