

IM-1700-AC/AH
IM-2000-AC/AH
PARTS LIST(220V/60Hz)
(Ver1.2)

2023. 05. 03

IM-1700-AC/AH, IM-2000-AC/AH

[OUT CASE ASSY]

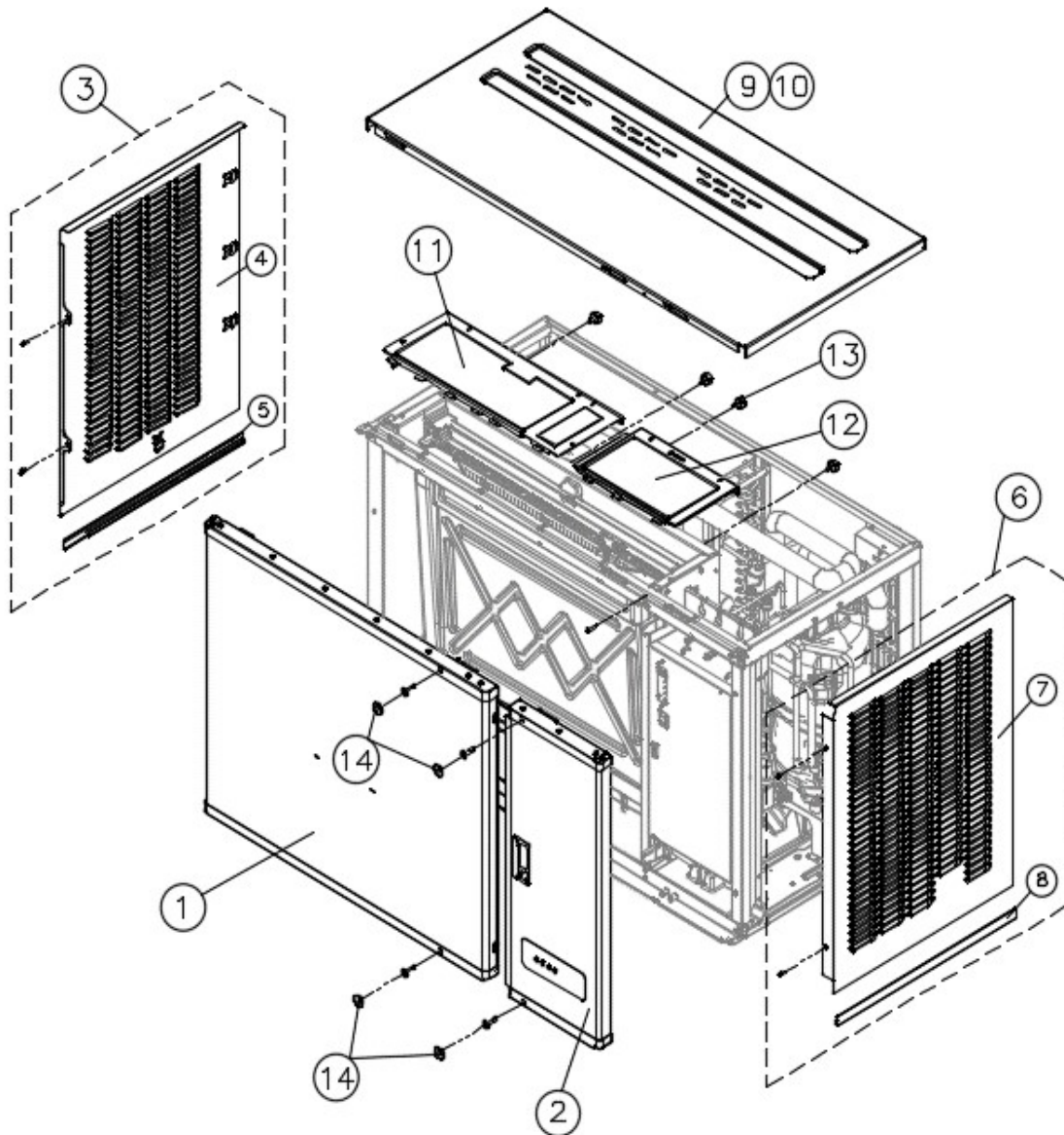

NO	ITEMS	CODE	Q'TY
1	FRONT PANEL(L) T-ASS'Y(48")	422003800	1
2	FRONT PANEL(R) T-ASS'Y(48")	422003900	1
3	LEFT SIDE PANEL ASS'Y	420049300	1
4	LEFT SIDE W-PANEL	349098900	1
5	SIDE PANEL B-ENDCAP(L)	348010200	1
6	RIGHT SIDE PANEL ASS'Y(48")	420053100	1
7	RIGHT SIDE W-PANEL	349109600	1
8	SIDE PANEL B-ENDCAP(R)	348010310	1
9	TOP COVER(48")	317224100	1
10	FOAM PE(TOP SPACE)	306049600	1
11	EVAP TOP COVER ASSY	427059100	1
12	EVAP TOP COVER ASSY®	427059110	1
13	HAND SCREW	210804502	4
14			
15			
16			
17			
18			
19			
20			
21			
22			
23			
24			
25			
26			
27			
28			
29			
30			
31			
32			
33			
34			
35			

IM-1700~, IM-2000~

[FRONT PANEL ASSY(L)]

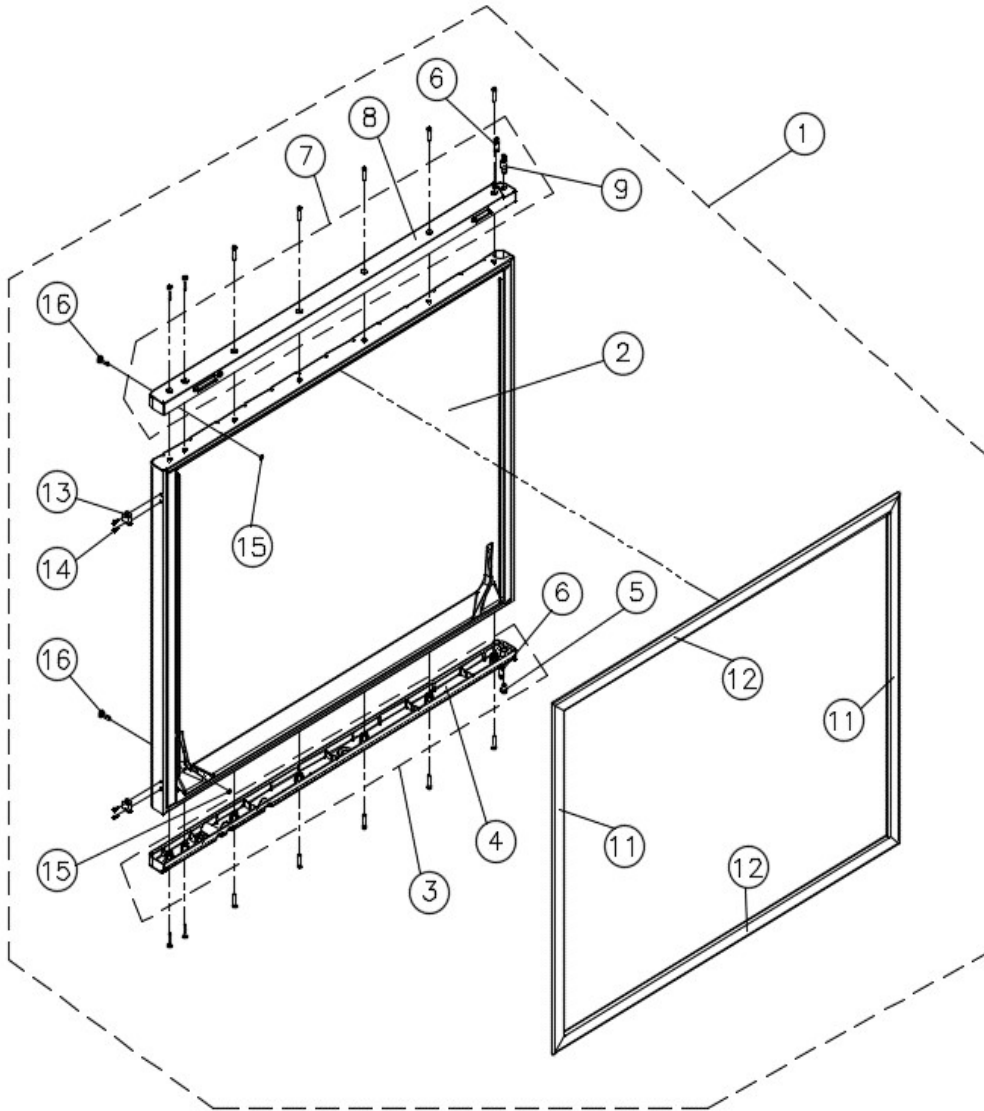

NO	ITEMS	CODE	Q'TY
	FRONT PANEL(L) T-ASS'Y(48")	422003800	1
1	FRONT PANEL FOAM ASS'Y	422004200	1
2	F-BOTTOM CAP(L) ASSY(48")	432052500	1
3	BOTTOM END CAP-L(48")	341016300	1
4	SHAFT HINGE	321005000	1
5	PIN-PUSH ASS'Y	314045500	2
6	F-TOP CAP(L) ASSY(48")	432052600	1
7	TOP END CAP-L(48")	341016200	1
8	PIN-PUSH ASS'Y(LONG)	314045510	1
9	CAP SILICON	319011120	2
10	F-PANEL GASKET(TOP/LOW)	656004500	2
11	F-PANEL GASKET(TOP/LOW)	656004530	2
12	KEEPER	631000600	2
13	MACHINE SCREW(FLAT HEAD M3x10)	MFCX0620R	4
14	O-RING(AN105-Φ2.62x IDΦ3.63)	303036600	2
15	COVER SCREW(M5xL20)	210818600	2
16			
17			
18			
19			
20			
21			
22			
23			
24			
25			
26			
27			
28			
29			
30			
31			
32			
33			
34			

IM-1700~, IM-2000~

[FRONT PANEL ASSY(R)]

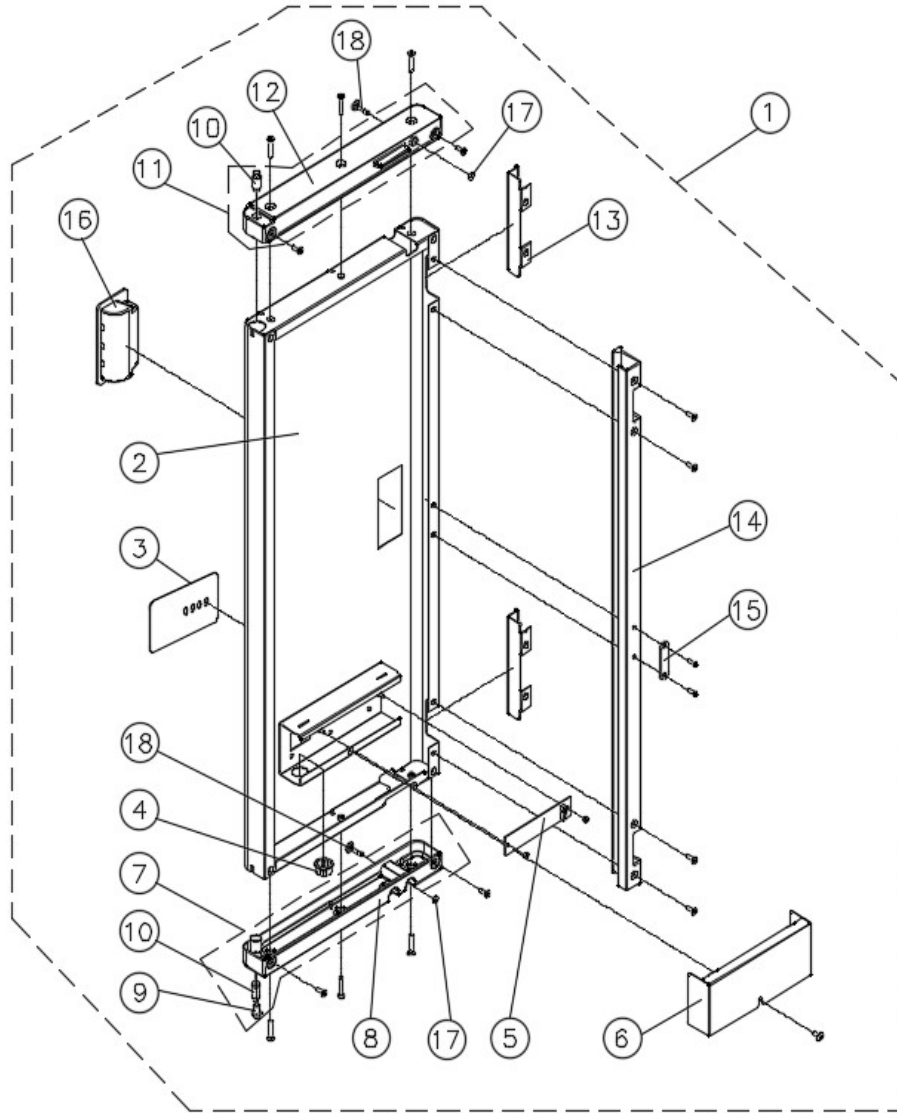

NO	ITEMS	CODE	Q'TY
	FRONT PANEL(R) T-ASS'Y(48")	422003900	1
1	FRONT PANEL(R) W-ASS'Y(48")	420052800	1
2	FRONT DISPLAY	440033820	1
3	GROMMET BUSHING	232003600	1
4	DISPLAY PCB	367013000	1
5	COVER DISPLAY-PCB	317224300	1
6	F-BOTTOM CAP(R) ASSY(48")	432052700	1
7	BOTTOM END CAP-R(48")	341016500	1
8	SHAFT HINGE	321005000	1
9	PIN-PUSH ASS'Y	314045500	2
10	F-TOP CAP(R) ASSY(48")	432052800	1
11	TOP END CAP-R(48")	341016400	1
12	F-DOOR REINFORCE	301218800	2
13	GAP FRAME(DOOR) (후가공)	339018510	1
14	LOCKING MAGNET PLATE	322006010	1
15	EMBEDDED PULL	319010800	1
16	O-RING(AN105-Φ2.62x IDΦ3.63)	303036600	2
17	COVER SCREW(M5xL20)	210818600	2
18			
19			
20			
21			
22			
23			
24			
25			
26			
27			
28			
29			
30			
31			
32			
33			
34			

IM-1700~, IM-2000~

[EVA S-PANEL ASSY(R)]

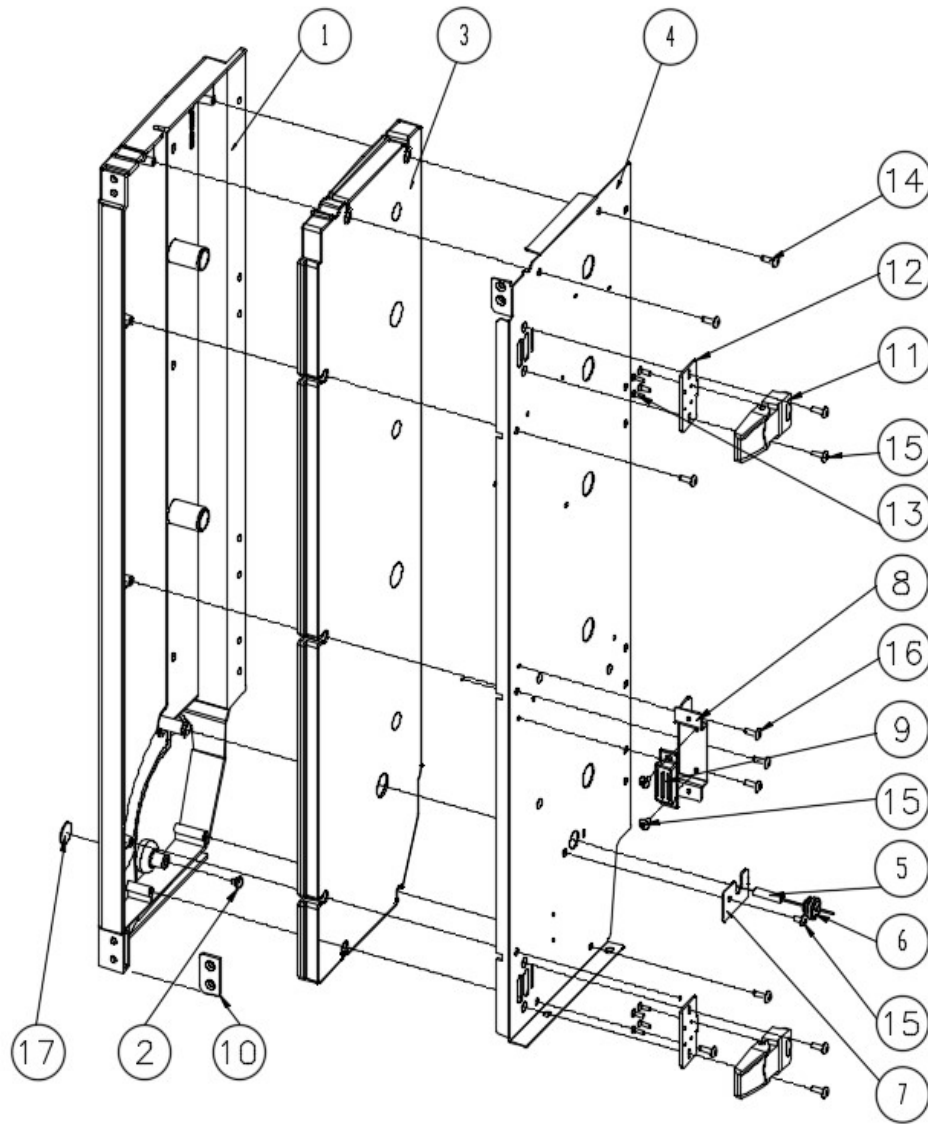

NO	ITEMS	CODE	Q'TY
	EVA S-PANEL ASSY-R	420053000	1
1	EVA S-PANEL(R)	339015901	1
2	HOLE-CAP	303041600	1
3	EPS SIDE INSULATION(R)	329037501	1
4	EVA S-PANEL COVER(R,48")	317224500	1
5	ASSY SENSOR MAGNET	701002000	1
6	SENSOR CAP	319009300	1
7	COVER BRACKET (M-SENSOR)	301169400	1
8	BASE BRACKET(MAGNET)	301219600	1
9	LOCKING MAGNET	322006000	1
10	PANEL INSERT-BRACKET(R)	301170201	1
11	DRAW LATCH	631000210	2
12	LATCH BASE BRACKET	301219200	2
13	MACHINE SCREW(FLAT M3x10)	MFCX0620R	8
14	TAPPING SCREW(TRUSS M4x10)	TTCQ0820R	7
15	MACHINE SCREW(TRUSS M4x10)	MTCX0820R	7
16	TAP TIGHT SCREW(TRUSS M4x8)	HTCX0820T	2
17	CIRCLE ADHESIVE STICKER	226003710	1
18			
19			
20			
21			
22			
23			
24			
25			
26			
27			
28			
29			
30			
31			
32			
33			
34			

IM-1700~, IM-2000~

[WATER IN/OUT ASSY]

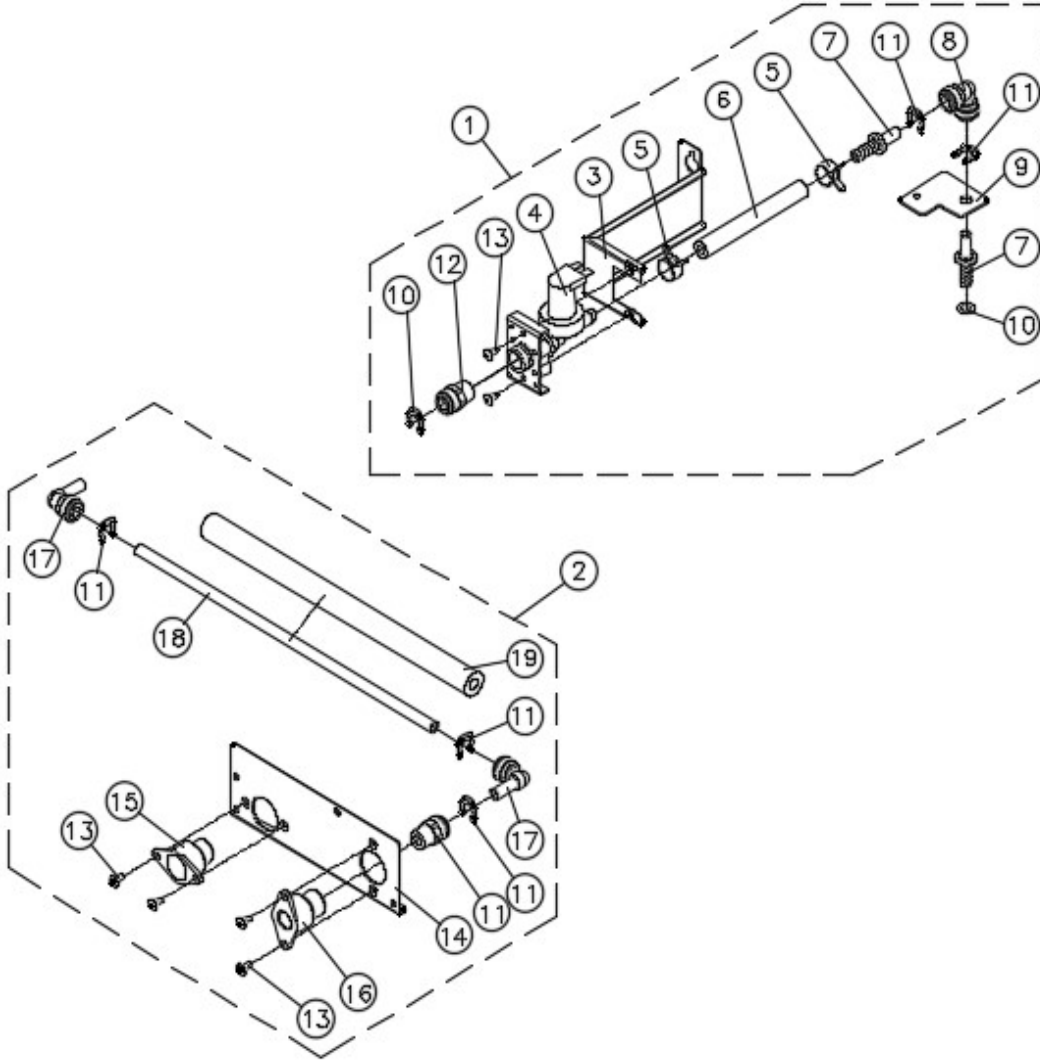

NO	ITEMS	CODE	Q'TY
1	WATER INLET VALVE ASSY(48")	469003900	1
2	WATER INLET HOSE ASSY(48")	469002810	1
3	WATER IN-VALVE BRACKET(48")	301219700	1
4	WATER INLET VALVE(220V 50/60Hz)	340027520	1
5	BAND SPRING 17	203003200	2
6	BRAIDED SILICONE HOSE	229027800	0.12
7	TUBE TO HOSE STEM	398014200	2
8	EQUAL ELBOW	398012000	1
9	WATER INLET FIX BRACKET	301219800	1
10	O-RING(AN110)	303036400	1
11	LOCKING CLIP(3/8)	224002000	3
12	STRAIGHT ADAPTOR(3/8)	398016500	2
13	MACHINE SCREW(M4x8)	MTCX0816R	6
14	WATER IN-OUT BRACKET	301171010	1
15	SOCKET(3/4" NPT, OD Φ20)	215013400	1
16	SOCKET(3/8" NPT-3/8" NPT)	215018700	1
17	STEM ELBOW	398013801	2
18	PE TUBE (OD 3/8)	229013500	0.35
19	PIPE INSULATION(ID 10, t5)	306009000	0.35
20			
21			
22			
23			
24			
25			
26			
27			
28			
29			
30			
31			
32			
33			
34			
35			

IM-1700~, IM-2000~

[WATER THROUGH & PUMP ASSY]

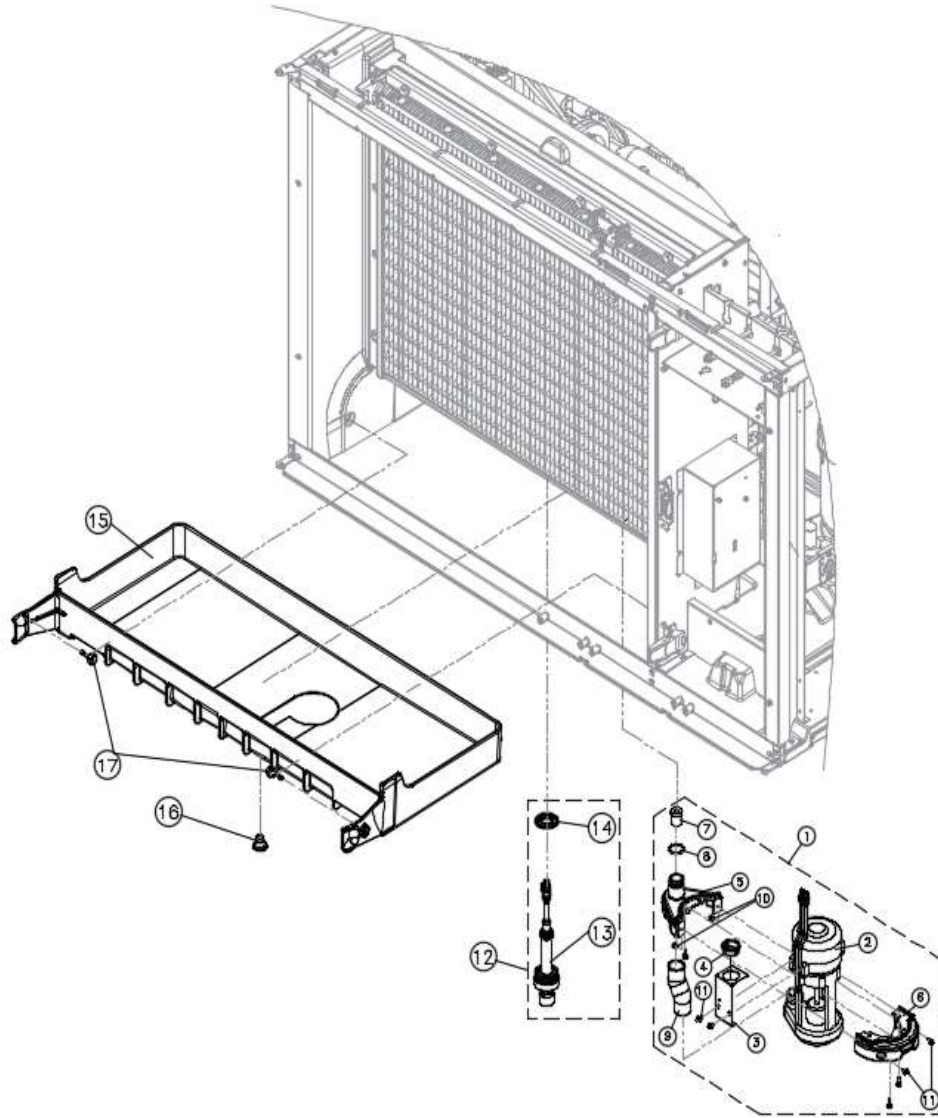

NO	ITEMS	CODE	Q'TY
1	WATER PUMP T-ASSY(H-DICE)	406023060	1
	WATER PUMP T-ASSY(DICE)	406023050	
2	PUMP MOTOR/SP-B6HLEJ26	353020401	1
3	HARNESS BRACKET(W-PUMP)	301170901	1
4	GROMMET BUSHING	232003500	1
5	WATER PUMP HOLDER(L)	339013600	1
6	WATER PUMP HOLDER(R)	339013700	1
7	PACKING ORIFICE(Φ15.5,H-DICE)	319010510	1
	PACKING ORIFICE(Φ11,DICE)	319010500	
8	O-RING(AN118)	303036200	1
9	CONNECTING HOSE(PUMP)	229031700	1
10	CAP NUT(M4, 전해연마)	210806000P	2
11	MACHINE SCREW(TRUSS M4x10)	MTCX0816R	4
12	WATER LEVEL PROBE ASS'Y	701004000	1
13	WATER LEVEL PROBE CAP ASS'Y	701003800	1
14	W. LEVLE RUBBER-HOLDER	303036100	1
15	WATER TROUGH(48")	339018600	1
16	PACKING DOWN	303022000	1
17	KNOB SCREW(M5)	210823210	2
20			
21			
22			
23			
24			
25			
26			
27			
28			
29			
30			
31			
32			
33			
34			
35			

IM-1700-AC/AH, IM-2000-AC/AH

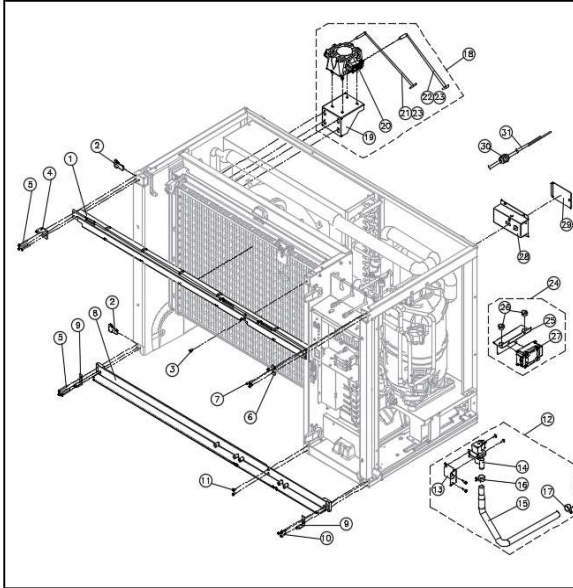

NO	ITEMS	CODE	QTY
1	FRONT TOP SUPPORT(48")	341016700	1
2	HINGE SUPPORT	341012300	2
3	MACHINE SCREW(FLAT M5x12)	MFCX1022R	1
4	TOP HINGE BRACKET-L(Electro Polishing)	32100861D	1
5	TAPPING SCREW(FLAT M4x40)	TFCQ0841R	6
6	HINGE BRACKET(Electro Polishing)	32100512D	1
7	MACHINE SCREW(FLAT M4x10)	MFCX0820R	3
8	FRONT BOTTOM-FRAME(48")	341016600	1
9	Polishing)	32100522D	2
10	MACHINE SCREW(FLAT M4x25)	MFCX0832R	3
11	MACHINE SCREW(FLAT M5x15)	MFCX1025R	2
12	WATER DRAIN VALVE ASS'Y(48" , 220V)	469004000	1
13	BRACKET DRAIN VALVE (DELTROL)	301169600	1
14	WATER VALVE (DELTROL AC220V)	340025800	1
15	DRAIN VALVE TO DRAIN-DELTROL (PVC)	229032100	1
16	BAND SPRING Z0	203004200	1
17	BAND SPRING Z1	203003300	1
18	AIR PUMP CIRCUIT ASS'Y	469004100	1
19	SUPPORT AIR-PUMP	318042300	1
20	AIR PUMP MOTOR	353036300	1
21	AIR HOSE ASS'Y(PUMP-L)	468020800	1
22	AIR HOSE ASS'Y(PUMP-R)	46802081D	1
23	CABLE TIE(100mm)	202000500	4
24	NOISE FILTER SUB ASS'Y	722018200	1
25	NOISE FILTER BRACKET	301171111	1
26	GROMMET BUSHING	232003600	2
27	NOISE FILTER	500002000	1
	POWER CORD & J-BOX ASS'Y	72201831D	
28	JUNCTION BOX(REMOTE)	37414811D	1
29	JUNCTION BOX COVER	317197900	1
30	BUSHING(HOLEΦ25 IDΦ18*ODΦ30	232000400	1
31			
32			
33			
34			

IM-1700-AC/AH, IM-2000-AC/AH

[COMP & CONDENSER PARTS]

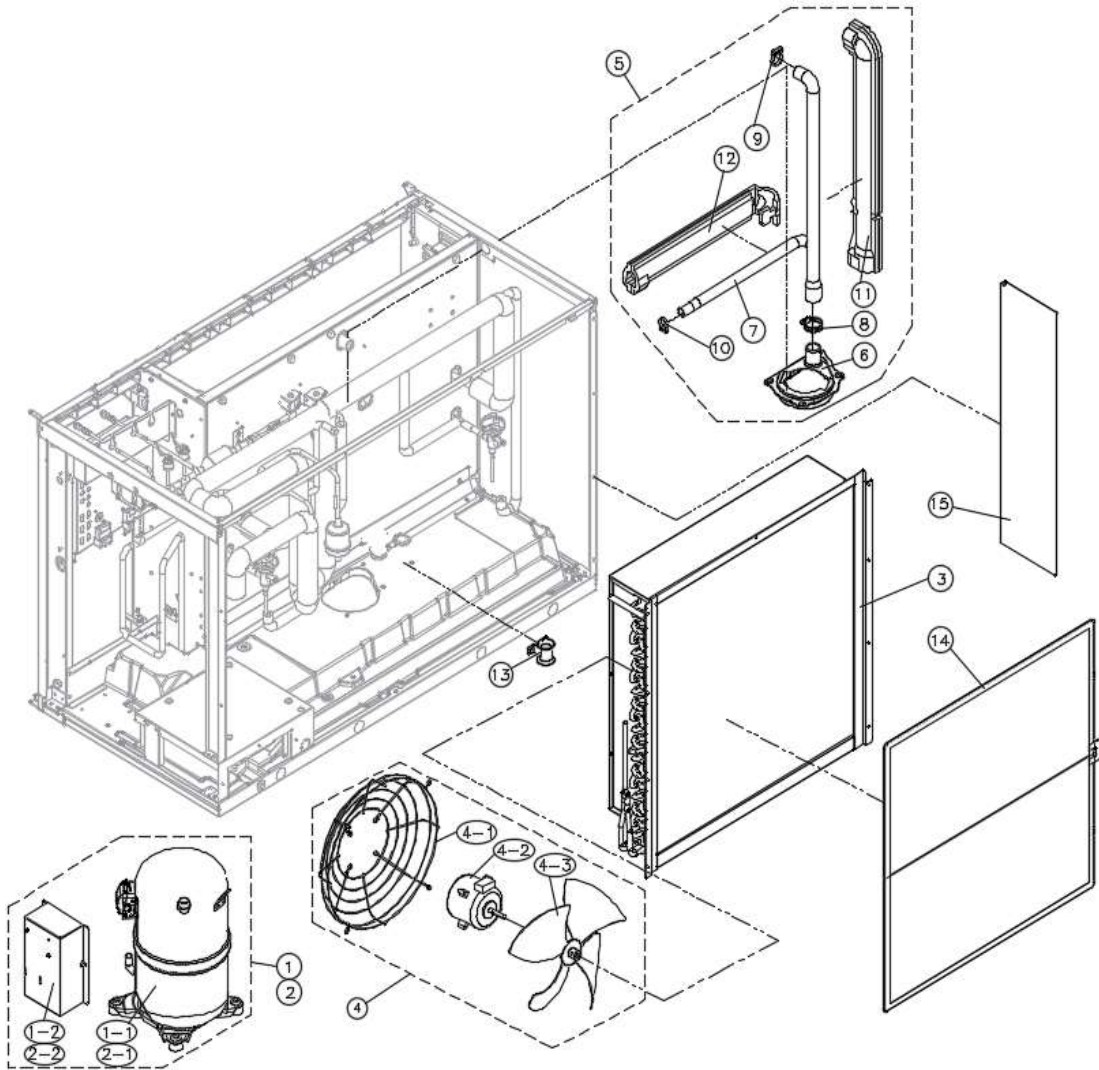

NO	ITEMS	CODE	Q'TY
1	COMP. ASS'Y(for IM-2000~)	-	-
1-1	COMP/H82J443ABCA	394024400	1
1-2	CSR BOX ASS'Y(H82J443ABCA)	426074600	1
2	COMP. ASS'Y(for IM-1700~)	-	-
2-1	COMP/H82J353ABCA	394024500	1
2-2	CSR BOX ASS'Y(H82J353ABCA)	426074610	1
3	CONDENSER ASSY	411036100	1
4	FAN MOTOR ASSY	353036200	1
5	WATER PUMP MOUNT ASSY (48")	463000710	1
6	WATER PUMP MOUNT	339013500	1
7	WATER CIRCU. & DRAIN TUBE(48")	229036700	1
8	BAND HOSE 40	203001400	1
9	CLAMP HOSE(SNP28 28"φ33,PA66GF13 흑색)	229026600	1
10	BAND SPRING 17	203003200	1
11	FOAM PUMP TO DISTRIBUTOR(500)	306042500	1
12	FOAM PUMP TO DRAIN(48")	306042110	1
13	WATER LEVEL PROBE-HOLDER	339014100	1
14	FILTER CONDENSER(W673 x H710)	640008810	1
15	AIR PROTECTOR	339016000	1
16			
17			
18			
19			
20			
21			
22			
23			
24			
25			
26			
27			
28			
29			
30			

IM-1700-AC/AH, IM-2000-AC/AH

[REFRIGERATION PARTS]

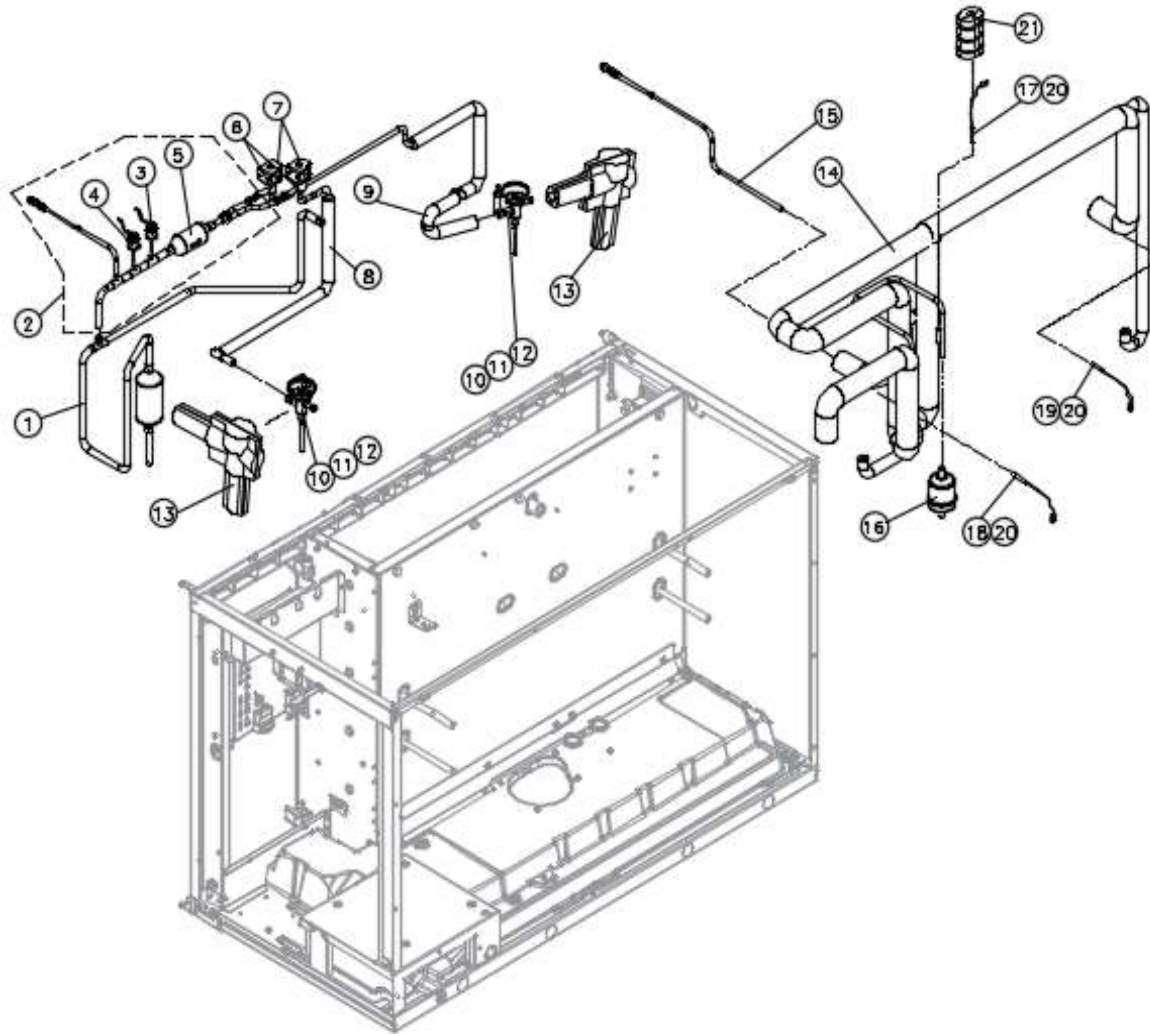

NO	ITEMS	CODE	Q'TY
1	DISCHARGE PIPE ASS'Y(48",AIR)	433047900	1
2	HOT GAS PIPE ASS'Y(48",AIE)	433047120	1
3	HIGH PRESSURE S/W ASS'Y	429010600	1
4	HIGH PRESSURE S/W ASS'Y(FAN)	429010700	1
5	STRAINER	605002200	1
6	SOLENOID VALVE BODY	340028200	2
7	ASSY SOLENOID VALVE COIL (220V)	429007000	2
8	HOT SOL TO TXV(R) PIPE	325163600	1
9	HOT SOL TO TXV(L) PIPE(AIR)	325166200	1
10	EXPANSION VALVE-(Inlet Flare TYPE)	340033000	2
11	ORIFICE(#2)	340033200	2
12	EXPANSION IN NUT ASSY	325161300	2
13	FOAM PE (EXPANSION)	306016700	2
14	HEAT EXCHANGE PIPE ASS'Y(48",AIR)	433048000	1
15	SUCTION CHARGE NIPPLE(48")	325164600	1
16	FILTER DRYER	372002900	1
17	EVA SENSOR SB(BLACK)	655008200	1
18	EVA SENSOR SB(BLUE)	655008210	1
19	EVA SENSOR SB(YELLOW)	655008220	1
20	SENSOR CLIP	224002400	1
21	FOAM SENSOR INSULATION	306043300	1
22			
23			
24			
25			
26			
27			
28			
29			
30			
31			
32			
33			
34			

IM-1700-AC/AH, IM-2000-AC/AH

[BASE & FRAME ASSY]

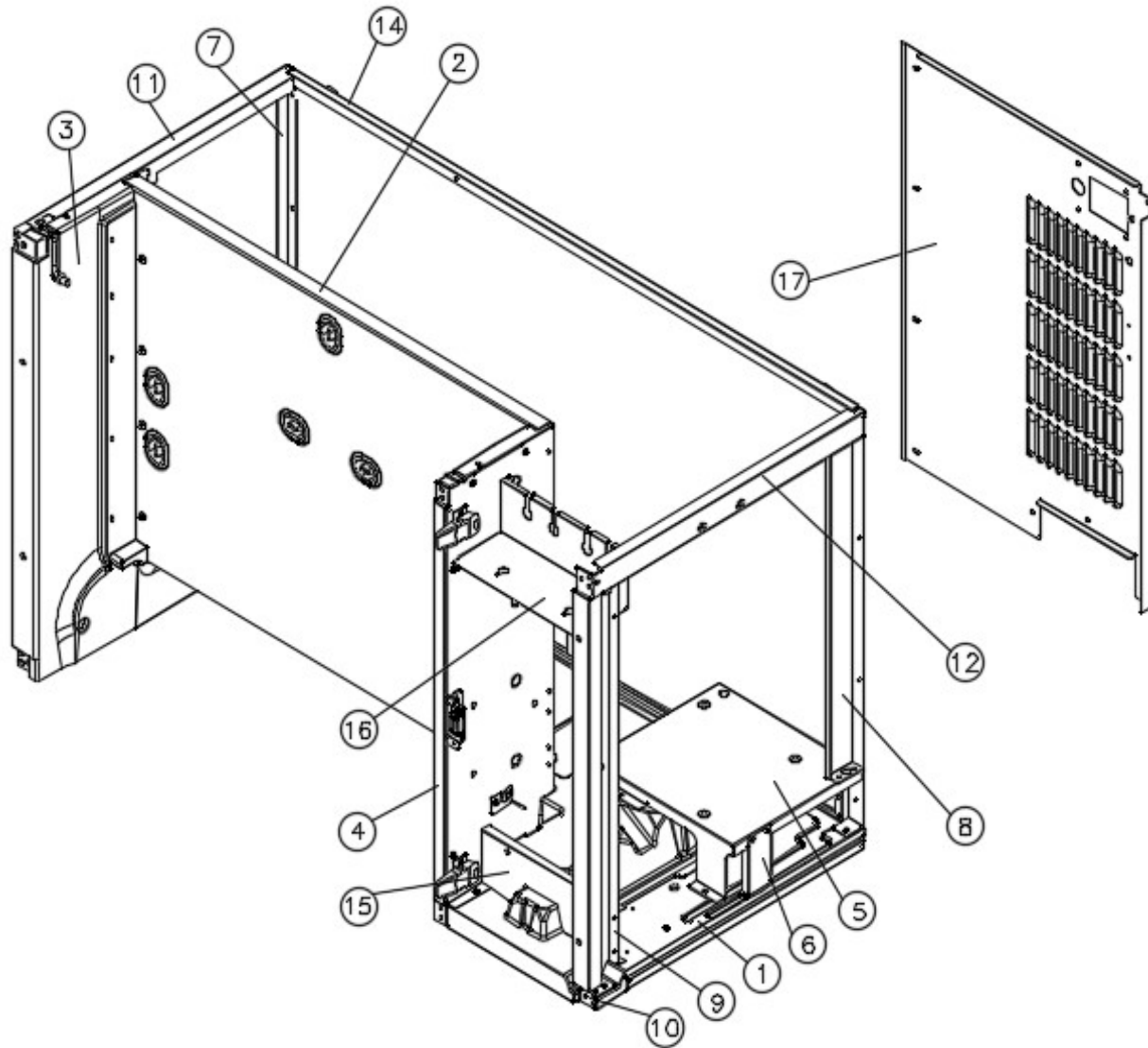

NO	ITEMS	CODE	Q'TY
1	BASE PLATE FOAM ASSY(48")	483032800	1
2	EVA. BACK PANEL ASS'Y(48")	422004000	1
3	EVA S-PANEL ASS'Y(L)	420049700	1
4	EVA S-PANEL ASS'Y(R)	420053000	1
5	SUPPORT COMP(48")	320594200	1
6	SUPPORT COMP. BRACKET	320593800	1
7	SIDE REAR FRAME(L)	348011300	1
8	SIDE REAR FRAME-R(48")	348021700	1
9	FRONT SIDE FRAME-R(48")	348021000	1
10	HINGE BASE BRACKET	301218900	1
11	SIDE TOP FRAME(L)	348010700	1
12	SIDE TOP FRAME-R(48")	348021100	1
13	-	-	-
14	REAR TOP FRAME(48")	348021500	1
15	CONTROL BOTTOM-REINFORCE	348021600	1
16	CONTROL TOP-REINFORCE	348021400	1
17	BACK PANEL(48",AIR)	349110200	1
18			
19			
20			
21			
22			
23			
24			
25			
26			
27			
28			
29			
30			
31			
32			
33			
34			
35			