

Ice / Water Dispenser User's Manual

MODEL : ID-0160-AN

- ※ This machine cannot be used in any other country where the electric voltage for its power supply is not available.
- ※ This product is designed for indoor installation. Please be sure to install it indoors.
- ※ The external appearance, design, color, and/or components of this machine may be changed without prior notice for the sake of the Company's product manufacture.
- ※ Please read the preparations for safety.
- ※ For maximum hygiene, be sure to clean and sterilize the product on a daily basis.

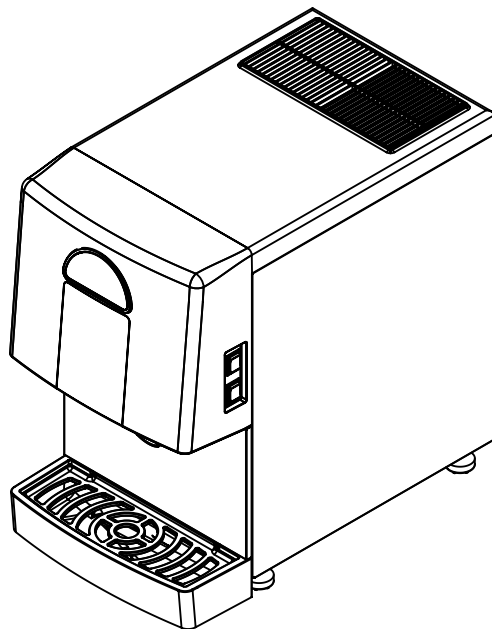

INDEX

| | |
|---|-------|
| 1. Safety Precautions | 3~7 |
| 2. Product Specification | 8 |
| 3. Appearance and Size | 9~10 |
| 4. How to install | 11~15 |
| – The installation place | 11~12 |
| – How to Disassemble the Panel | 13 |
| – Connection method for water supply and drainage | 14 |
| – About grounding | 15 |
| 5. How to start the product | 16~19 |
| – Button operation | 17 |
| – Function button description (FND display window) | 18 |
| – Three drainage functions | 19 |
| (forced drainage, automatic draining, water drainage) | |
| – Stop switch | 19 |
| 6. Required precautions to prevent frost | 20 |
| – Water removal in water tank and evaporator | 20 |
| 7. Maintenance, repair and disinfection | 21~24 |
| – Maintenance schedule | 21 |
| – Cautions for cleaning the external panel(stainless steel) | 22 |
| – How to clean and disinfect | 23~24 |
| 8. Circuit diagram | 25 |
| 9. Error type | 26 |
| 10. Before Requesting Service | 27 |
| 11. Product Warranty | 28 |

1. Safety Precautions

Warning

When there is a risk of causing physical problems such as death or serious injury in the event of improper use.

Caution

When injury or damage to property such as house or furniture may occur in the event of improper use.



SHOULD BE DONE



PROHIBITION



DO NOT
DISASSEMBLE



DO NOT
TOUCH



DISCONNECT
POWER PLUG



GROUNDED

Warning

Use a single receptacle for the ice machine.

- ◆ An electrical fire may be caused by a receptacle holding more than one item.
- ◆ Do not use an adapter or an extension cord.

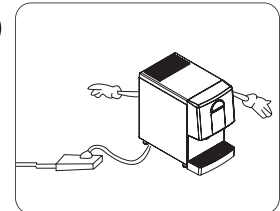

Clean the plug

Clean the plug if covered in foreign material or dust etc. with a clean, dry towel.

- ◆ A fire may occur if plug is not cleaned.

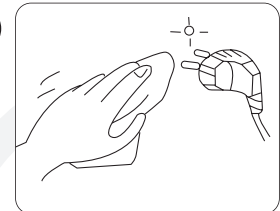



Warning

Do not place heavy objects or containers containing water on the ice maker.

- ◆ The objects or containers may fall and cause water to leak and the insulation may be weakened, resulting in a fire due to a short circuit.

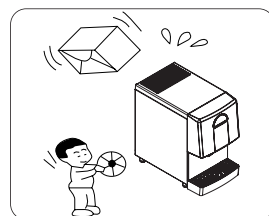

Do not install the product in a humid place or where there is a risk of water splashing.

- ◆ Insulation may be weakened, resulting in short circuit, electric shock, or fire.

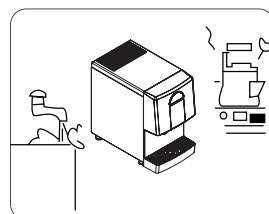

Do not use

If the product malfunctions, such as smoke or burning smell, unplug the power cord to stop operation.

- ◆ If you continue operating in abnormal conditions, there is a risk of fire or electric shock.

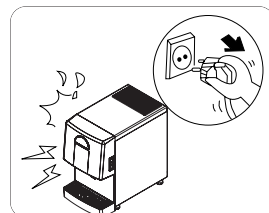

Do not use

Do not use flammable spray around the ice maker.

- ◆ Risk of explosion or fire.

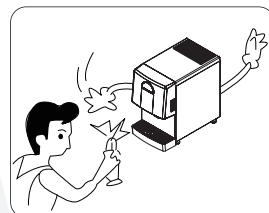

Do not use

Do not use if the outlet is loose or has a problem.

- ◆ There is a risk of fire due to electric shock or short circuit.

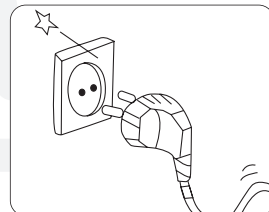



Warning

Disassembly forbidden

Do not modify or repair the product yourself.

- ◆ Ignition or abnormal operation is dangerous and may cause more trouble.

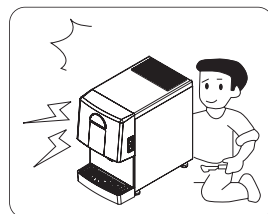

Prohibition

Do not allow electrical cords or plugs to be pinched or twisted.

- ◆ The cord or plug may be peeled and there is a risk of fire or electric shock.
- ◆ If the cord or plug is peeled or damaged, be sure to ask the service to replace it.

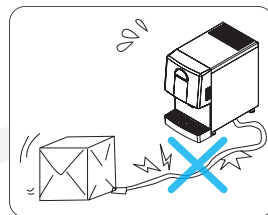

Prohibition

Do not let children hang on the product.

- ◆ There is a danger of the ice maker twitching or falling, resulting in injury.
- ◆ In particular, please do not let children hang on the reservoir not fixed to the product.

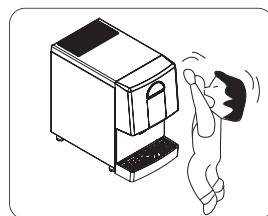

Do not touch

Do not touch or pull on the power plug with wet hands.

- ◆ There is a danger of electric shock.

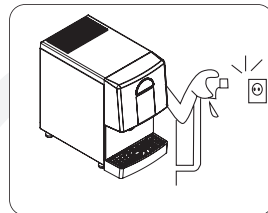

Do not touch

Do not damage the inside of the ice maker with a sharp tool.

- ◆ The ice reservoir may break or become damaged.

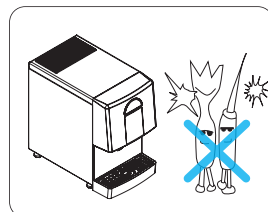



Warning

Disconnect power plug

When not in use for a long time, remove ice and water (to prevent winter frost), and unplug the power cord from the outlet.

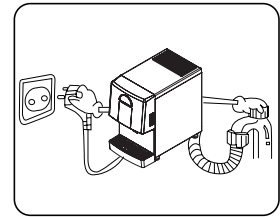

Disconnect power plug

When cleaning dust or replacing parts, unplug the power plug first.

- ◆ It may cause electric shock or fire.

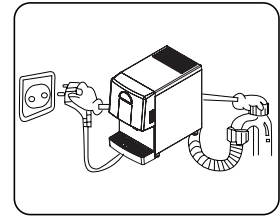

Disconnect power plug

When unplugging, grasp the plug body and remove it

- ◆ It may cause fire or spark when unplugged by plug wire or driver.

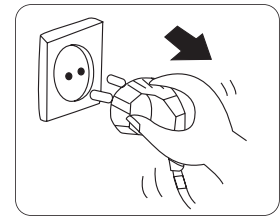

Grounded

Please be sure to ground.

- ◆ There is a risk of machine failure or electric shock due to short circuit.

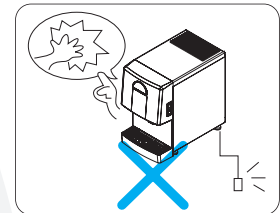

About the power strip

When using multi-tap, please use 250V, 16A or more.

- ◆ Do not plug in multiple plugs at the same time. Connecting multiple plugs to a power strip will cause a fire.

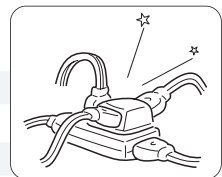



Caution

Caution

If there is a risk of slippery water or oil on the floor near the ice maker, please wipe it.

- ◆ There is a risk of injury if you slip on the ice maker or get hands or feet in the bottom of the side.

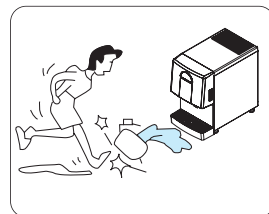

Hand over

When transferring this ice maker to another person, please hand it along with the instruction manual

- ◆ New users need a manual for safe use.

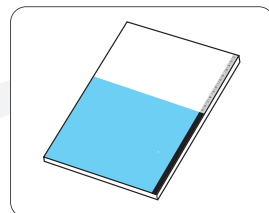

Do not put your hands or feet on the bottom of the ice maker.

- ◆ The bottom of the ice maker have iron plates and various parts which may cause injury.

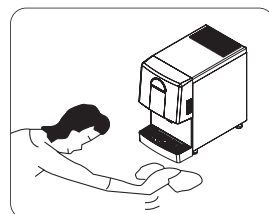

If you unplug the power plug from the wall outlet and plug it back in again, wait at least 5 minutes before reinserting.

- ◆ If it is plugged in immediately, it may cause a trouble in operation of the freezer and it may cause malfunction of the ice maker.

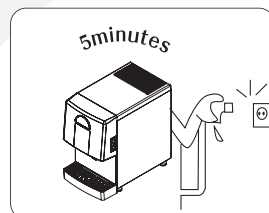

For areas where water contains much calcareous sediments, be sure to install a calcium filter at the water inlet port (calcium may reduce the lifecycle of the product).

2. Product Specification

| Category | | Specification |
|---|-----------------------|--|
| Model | | ID-0160-AN |
| Ice shape | | Nugget |
| ※ Maximum capacity Ambient temperature 50°F, Water temperature 50°F | | 160 lb/day (73kg/day) |
| Storage capacity | | 6.2lb (2.8kg) |
| ※ Size (W X D X H) – Foot excluded | | 13.8" X 23.8" X 22.8" (350X605X580mm) |
| Power Supply | | AC 115 V 60 Hz, 1PH |
| Current consumption | | 2.75 A |
| Weight | Before packaging | 101 lb (46kg) |
| | After packaging | 117 lb (53kg) |
| Compressor | | 1/6 HP |
| Condensation method | | Air-cooled |
| Refrigerant | | R-134A |
| Deceleration motor | Power Supply | AC 115 V 60 Hz, 1PH |
| | Rated output | 40 W |
| Discharging method | | Solenoid |
| Installation environment standard | Specification | 50~100 °F (10 ~ 38 °C) |
| | Water temperature | 50~90 °F (10 ~ 32 °C) |
| | Supply water pressure | 20~80psi |

※ Maximum production is based on ambient temperature and water temperature 50 °F. However, the deviation may occur depending on the conditions of the installation environment, and the deviation may increase at high temperature conditions such as the summer season.

※ ※ Depending on the specifications of the reservoir, the size may be different, please check before purchase.

3. Appearance and Size

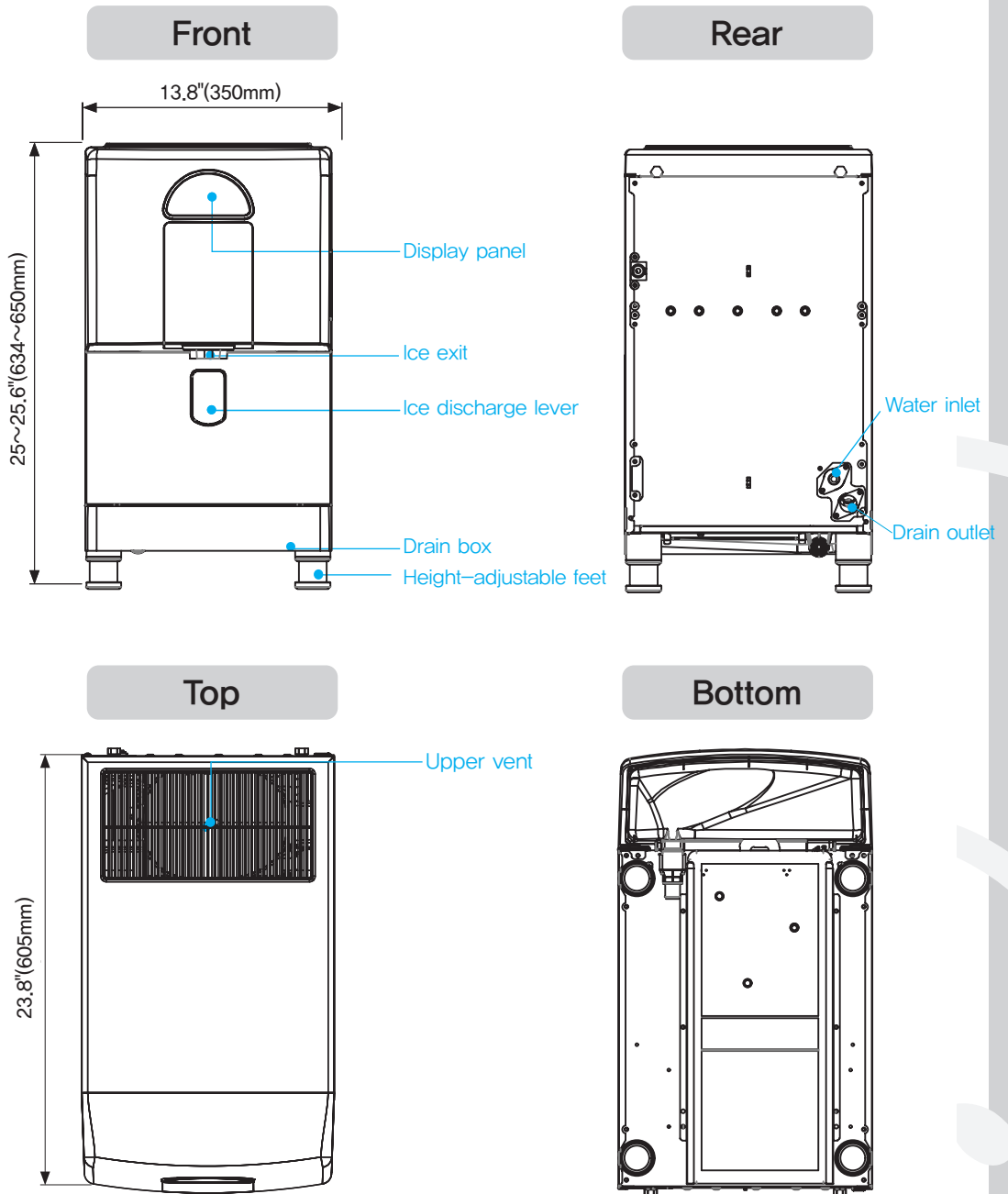

Left

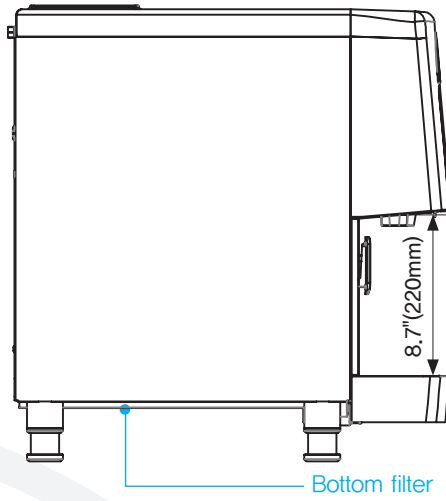

Right

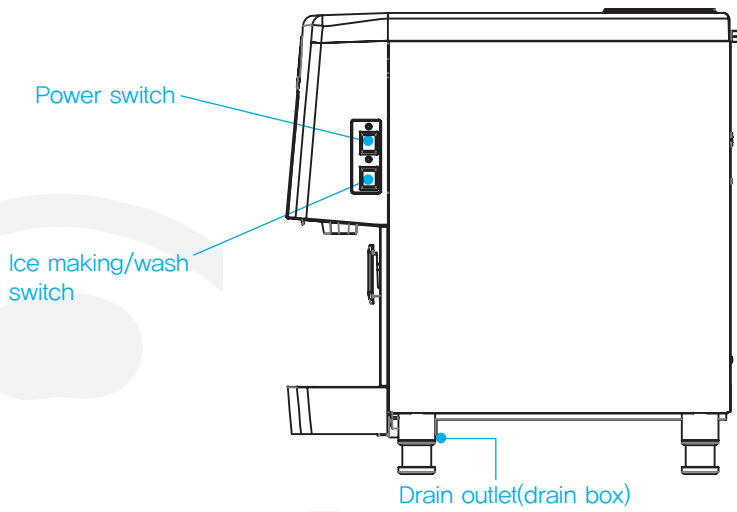

4. How to install

The installation place is like this ...

○ Where there is no heat source ...

- ◆ Install in a place where there is no heating device such as a fireplace or a gas range, and do not install in an area outside the range of 50~100°F.

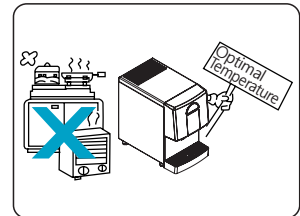

○ Where the space with the wall is reserved ...

- ◆ For normal operation, install the ice maker at least 7.8" away from the wall.
- ◆ For cleaning and maintenance of the auger, 39.4" space should be reserved above the top of the ice maker.

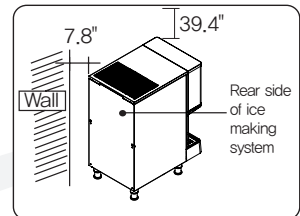

※ Never block the upper vents and do not place any load on it.

[Please follow the procedures when moving the machine]

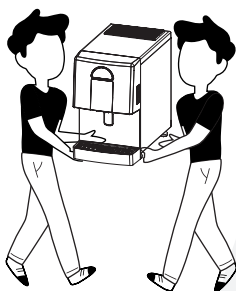

(O)

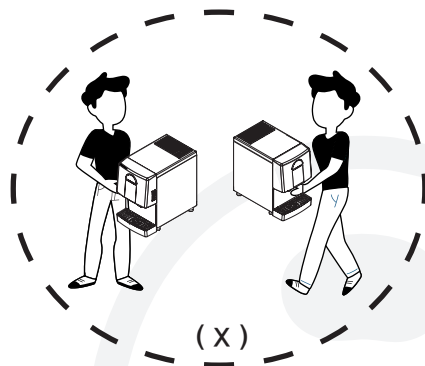
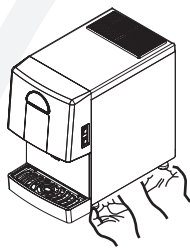

(X)

※ Two people should hold the bottom of the machine together to move it.

※ Do not hold onto the door of the machine. It might damage the door.

⦿ Where good ventilation is secured...

- ◆ If the ventilation is poor, the ICE MAKING ability will decrease.

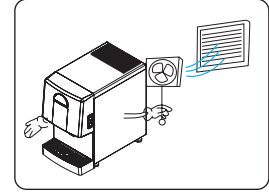

⦿ Installation is on a flat ...

- ◆ Unstable installation may cause vibration and noise. (Installed within 1 °)
- ◆ It is recommended to install it on a flat surface because there is a possibility that the product will fall and cause injury when the installation is made in a sloping place.

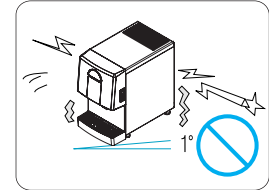

⦿ Please install in hygienic place.

- ◆ Ice is used for edible purposes, so please always install the product in a sanitary and clean place.

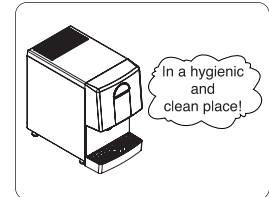

⦿ Installation should be indoors.

- ◆ Install the drain hose at an angle so that drainage is good.
- ◆ Do not install outdoors.

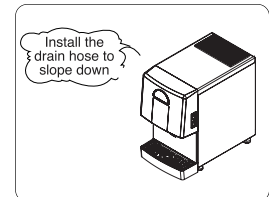

⦿ Install in a child-restricted area.

- ◆ Please be careful about the safety accident of a child and do not let dangerous jokes such as picking up the ice in particular.

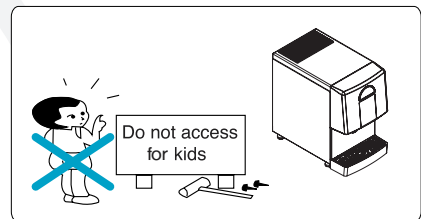

◆ Make sure to observe the following.

- Since the product makes use of water, proper water supply and draining facility are required.
- Water may leak during installation or operation for diverse reasons. Thus, proper draining must be prepared. Since there is danger of electric shock due to moisture from leak, be sure to observe the following:
 1. When installing the product indoors, be sure to have a natural drainage facility and make the floor waterproof, especially if the floor may get damaged due to leak.
 2. A draining outlet must be available at the installation site; be sure to connect the drain hose.
 3. Make sure that the floor is sloped so that any leaked water gets drained away even if the drain hose gets dislodged or damaged. Install a water overflow prevention wall to prevent damage.
- ※ Adjust the height by turning the footing if the floor is sloped to set it stably.
- ※ The manufacturer will not be liable for any problem arising from failure to comply with the warnings above, dislodged / damaged water supply hose, or inappropriate drain facility.



Warning

How to Disassemble the Panel

1. Top Panel: Loosen the 2 rear screws, push the top panel back, and lift it up to disassemble.
2. Side Panels: Remove the front drain box and the top panel, loosen the front and rear lower screws, and then spread the bottom left and right, then lift up to separate.
3. Front Panel: Loosen the two lower left and right screws, pull the lower part toward the front, and lower it to disassemble.
4. Front Cover: After removing the top panel, remove the fixing screws and disassemble by tilting it forward.

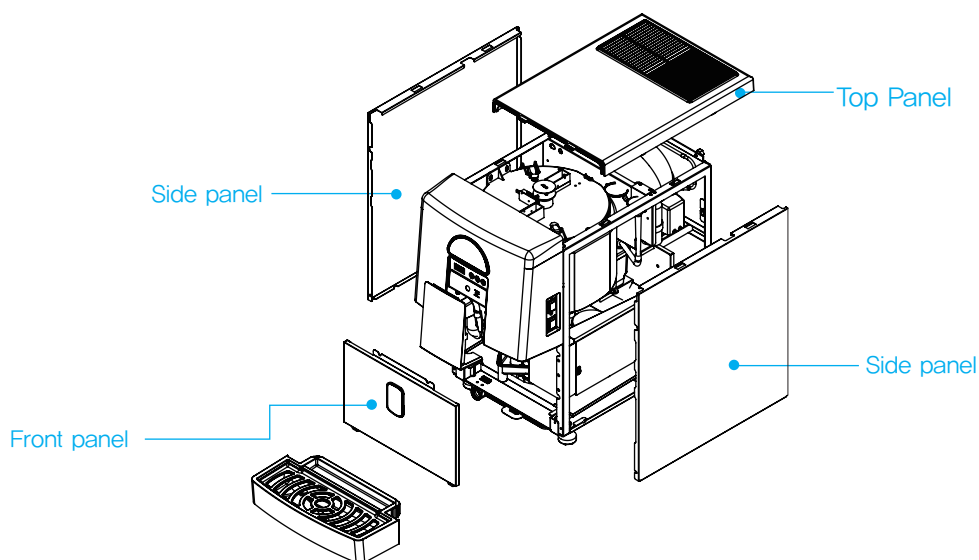

※ Please assemble in the reverse order of disassembly.

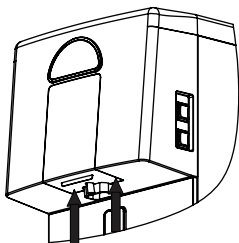

※ Ice Chute Cover: It is disassembled by pulling the lower part toward the front. When assembling, align it with the upper groove and push the lower part upward to fix the hook.
(If the ice outlet cover is removed, the dispensing operation does not work)

Connection method of water supply and drainage

[Connection of water and drainage hoses]

| Division | Proper water temperature | Water pressure | Hose to be used |
|-------------------------|--------------------------|----------------|-----------------|
| ICE MAKING water supply | 50~90°F | 20~80psi | NPT 3/8" |
| ICE MAKING drainage | — | — | NPTF 3/4" |

If the temperature of the ICE MAKING water supply is too high, the amount of ICE MAKING may be reduced, If the water pressure is too low, it may not be possible to freeze. In this case, an auxiliary hydraulic pump should be installed.

Connect the $\phi 6.35$ PE TUBE to the bottom right of the product as shown in the picture and secure the clip to prevent hose detachment.

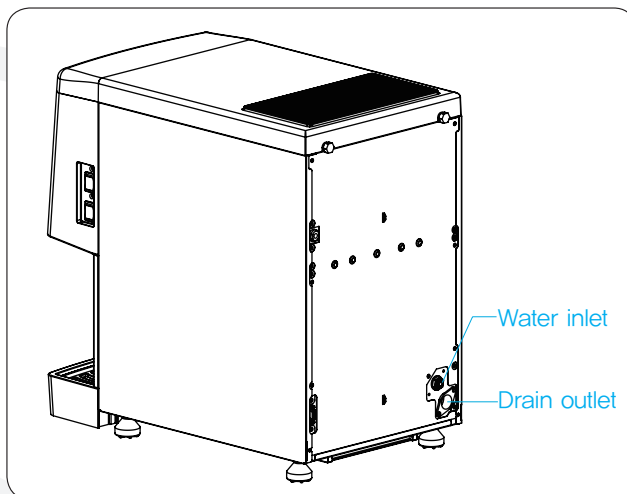

※ After the installation is complete, please operate the product and check whether there is leakage in the water supply and drainage parts.



Please connect a hose with an inner diameter of $\phi 20\text{mm}$ ($\phi 0.78''$) or more for the ice making drain hose and the drain outlet should be 5cm (1.97'') above the drain floor level. (If the drain outlet dip in the drainage, the drainage may flow back into the ice maker and damage the product and the floor.)

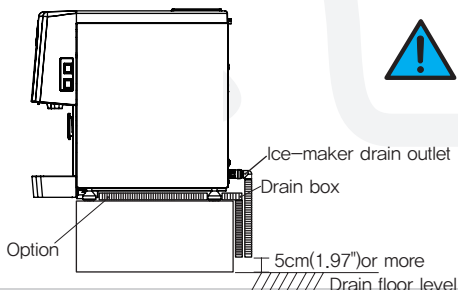

Be careful not to bend the drainage hose during the installation and also confirm that the hose is not exposed to fire or sharpness which may result in the hose burst.

(This will become the cause of the PL accident and the manufacturer shall not be held responsible.)

About grounding

※ Please be sure to ground to prevent electric shock.

⦿ Grounding method – When there is a grounding terminal

In case of plugging the icemaker into a power outlet equipped with a grounding terminal, extra grounding is unnecessary.

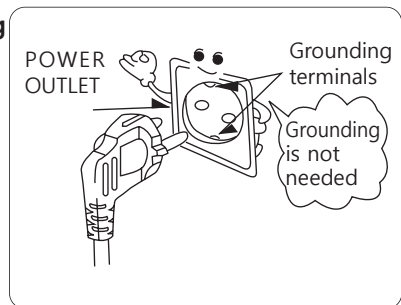

⦿ Grounding method – When there is a grounding terminal

In case of plugging the icemaker into a power outlet without a grounding terminal, connect the ground wire to the copper plate and then bury it under the ground.

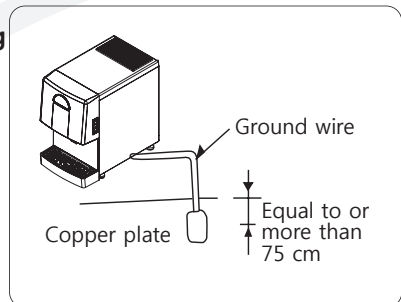

Do not ground in these places.

Never connect to a gas pipe, water pipe, pipe, lightning rod, telephone line, or connection.

※ Plastic water pipes and non-insulated materials do not have a grounding effect.

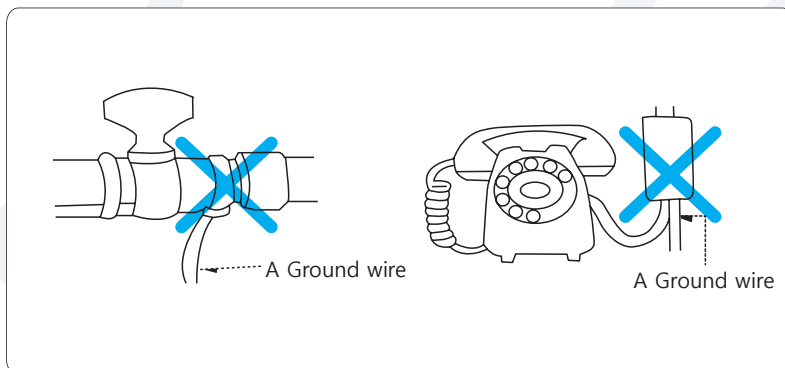

5. How to start the product

⦿ Water supply hose protection

Do not place heavy objects on the water supply hose leading to the water supply, or keep the hose from treading.

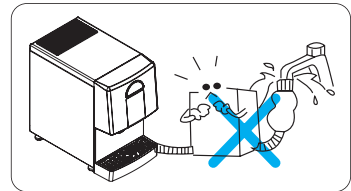

⦿ Proper water pressure, water temperature, ambient temperature

Please use this ice maker only in the area where water pressure is 20~80psi, water temperature is 50~90°F and ambient temperature is 50~100°F.

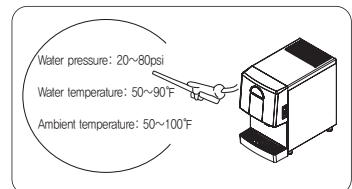

Please connect only the water you can drink.

1. Power connection

- ◆ This icemaker operates only on rating volts. Plug it into a rating outlet only.

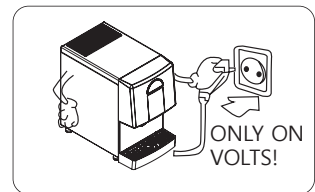

2. Water supply

- ◆ Please open the faucet and let the water supply.

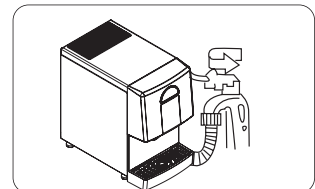

3. ICE MAKING operation

- ◆ Open the front door and turn on the power switch to start the ice making operation.
- ◆ Turn the ICE MAKING—OFF—WASH switch to ICE MAKING

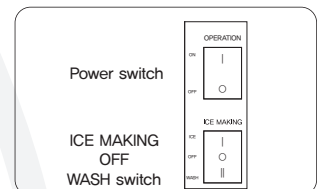

4. Start ice production

- ◆ There is a slight difference depending on the ambient temperature and water temperature, ice starts to be generated from about 3 minutes after starting the ice making operation, After about 70 minutes, the reservoir will be full of ice. (You can use ice after about 10 minutes.)

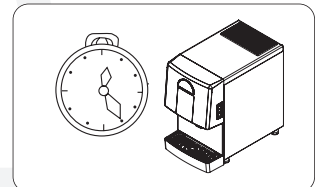

Button Operation

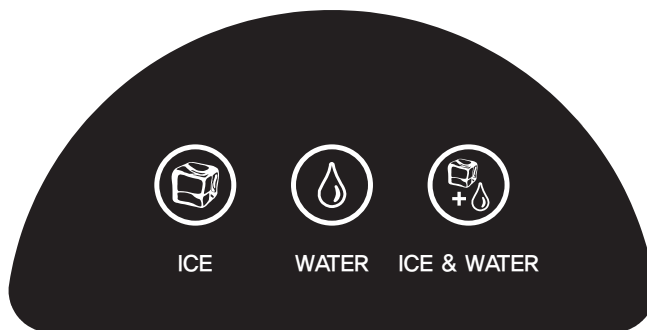

ICE button lamp

- If you turn on the power, this will always come in first. The initial water subtraction is done three times and then the ICE MAKING operation is proceeded. If you put the cup in the ice exit, you can discharge the ice for the time set in F1.

WATER button lamp

- Press the button to light up. If you put the cup on the ice exit, you can discharge the water for the time set in F1.

ICE + WATER button lamp

- Press the button to light up. If you put the cup on the ice exit, you can simultaneously discharge ice and water for the time set in F1.

When ERROR occurs

- ICE–WATER–ICE & WATER button will flicker in order and will disappear when restarting after the action against the ERROR.

Service cycle setting notification (parts check / replacement cycle notification)

- If the motor is running for more than 10,000 hours, the corresponding lamp blinks for 5 seconds in the initial stage of the ice maker.
- If the motor is operated for more than 11,000 hours, all the buttons will blink for 5 seconds in 1 hour cycle.

※ If all the buttons are flashing, it is a signal to check / replace regular replacement parts and you should contact the customer service center (paid service).
Failure to check / replace parts may result in higher repair costs.

Function Button Description (FND Display Window)

F. 1 (Maximum Discharge Time)

- ① SOLENOID Maximum operating time adjustment function.
- ② 3rd, 4th digits: 20 seconds (5 seconds ~ 30 seconds, Set Unit of one second).

F. 2 (Complete removal of ice in the reservoir)

- ① This function can be entered in "OFF" state of ICE MAKING–OFF–WASH switch.
- ② Press two buttons (WATER, ICE) simultaneously for 3 seconds and Button part LED lights up.
- ③ Press the discharge lever for continuous operation of SOLENOID and the motor. **Keep 'ON' state.**

F. 3 (Automatic ice discharge function)

- ① When ICE, WATER & ICE button is selected, ice is automatically emitted for the set time.
- ② Automatic operation is not possible when OFF is set. (Manual operation)
- ③ Automatic discharge is performed for the set time of At01 ~ 99.

F. 4 (Initial water subtraction function)

- ① It operates first when "ICE MAKING" switch is operated.
- ② FND 1st, 2nd digits (drain time) 30 seconds (oF ~ 99 seconds, Set Unit of one second)
- ③ Water supply operation after drainage to high water level.
- ④ FND 3rd, 4th digits (number of repetitions) Standard: 3 times (1 ~ 9 times)

F. 5 (Automatic drain function)

- ① It operates when "ICE MAKING" switch is operated.
- ② FND 1st, 2nd digits (drain time): 2 seconds (oF ~ 9 seconds, Set Unit of one second)
- ③ FND 3rd, 4th digits (drain interval): 1.0 hour (0.5 ~ 9.5 hours, every 30 minutes)

F. 6 (ICE + WATER volume control)

- ① 1st, 2nd digits Ice time Default 5 seconds (up to 99 seconds)
- ② 3rd, 4th digits Water time Default 5 seconds (up to 99 seconds)

※ Setting value reset function
– Pressing three buttons of UP, DOWN, and SET for 3 seconds at the same time will set all setting values to default values

F. 7 (UV LAMP time adjustment)

- ① 1st, 2nd digit lighting time Default 3 minutes (99 minutes possible)
- ② 3rd, 4th digits off time Default 1 hour (9 hours available)

F. 8 (Notify service period setting)

- ① A.1.0 After using 10,000 hours, the corresponding mode LED blinks for 5 seconds (for the first 5 seconds during ice making)
- ② A.1.1 After using 11,000 hours, all LEDs blink for 5 seconds (1 hour cycle)

F. 9 (Cumulative uptime)

- ① The FND display is displayed in year, month, day, and hour, and is displayed in order from right to left.
- ② Cumulative operation time of product is expressed in hour unit.
- ③ Calculation example: 12 months for 1 year, 30 days for 1 month, 24 hours for 1 day.

F. 10 (Change temperature unit)

Function of setting the unit of temperature in degrees Celsius or Fahrenheit

F. 11

Evaporation inlet temperature display

F. 12

Evaporation outlet temperature display

F. 13

Choose ice and water discharge method
ordE : Discharge ice first and then discharge water
join : Simultaneous discharge of ice and water

Three Draining Functions(Forced Draining, Automatic Draining, Water Draining)

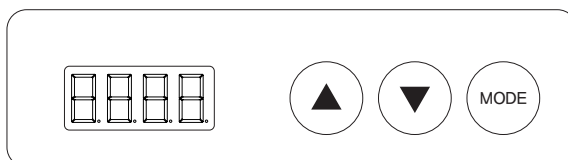

- 1) Forced drainage function (Must be implemented to prevent freezing in winter storage. Please also use this function for cleaning the inside.)
 - Turn on the power switch and press the "DOWN + SET" button simultaneously for 3 seconds with any signal on the FND display. (30 seconds)
- 2) Automatic drain function (F. 5)
 - Turn on the power switch and turn the ice making switch to "ICE MAKING" to start the operation.
 - ① FND 1st, 2nd digits (drain time): 2 seconds (oF ~ 99 seconds, Set Unit of one second).
 - ② FND 3rd, 4th digits (drain interval): 1.0 hour. (0.5 to 9.5 hours, every 30 minutes)
- 3) Initial water draining function (F. 4)
 - Turn the power switch off and then on again (the ICE MAKING–OFF–WASH switch at "ICE MAKING" position) to operate the function.
 - ① Clean the water line and ice making cylinder thoroughly.
 - ② FND 1st, 2nd (drain time) 30 seconds (oF ~ 99 seconds, Set Unit of one second).
 - ③ Water supply operation to high water level after drainage.
 - ④ FND 3rd, 4th digits (number of repetition) Reference: 3 times (1 ~ 9 times).

Stop switch

With the power switch turned on, turn the "ICE MAKING–OFF–WASH" switch to center OFF, then the ice making stops and the motor runs for another 60 seconds.
 This function protects the motor by removing the ice remaining in the product.
 If you sell the remaining ice even when it is OFF, ice discharging will be done.
 (At this time, water, water + ice will not work.)

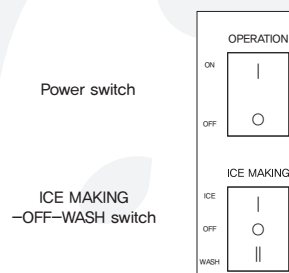

6. Required Actions to prevent frost

Water Removal in Water Tank and Evaporator



Caution

If the ambient temperature falls below 32°F, water will freeze inside the machine and machine operation will be impossible.

If you do not use for a long period of time in winter, be sure to completely remove the ice making water inside the body by following the instructions below. If you do not remove the ice making water or if it is insufficient, it will cause serious damage to the product.

This shall not be guaranteed by the manufacturer and may result in a lot of repair costs. Please observe the following points.

1. Turn on the power switch and press the DOWN + SET button at the same time for 3 seconds with any signal on the FND window. Forced drainage will be done for 30 seconds.
2. Turn off the power switch and disconnect the power plug from the outlet.
3. Remove the left panel → the front panel.
4. Remove the evaporator cylinder drain hose clamp and remove the hose, and wait until the ice in the evaporator cylinder completely melts down. (It is possible to remove internal water quickly by using compressed air gun etc.)
5. Reassemble the evaporator cylinder drain hose and tighten the clamp.
6. Assemble in the order of left panel → upper panel → front panel

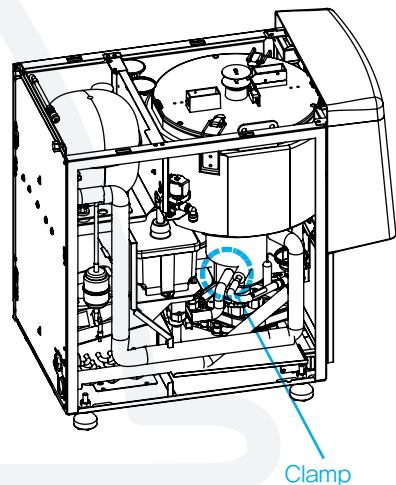
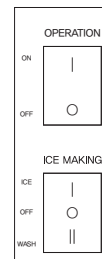

7. Maintenance, repair and disinfection

※ Please keep the product according to the instruction manual and label provided.



- Be sure to have a qualified service technician service the product.
- To reduce the risk of electric shock, do not touch or disassemble the parts of the ice maker.
- Before service
 - Turn off the power switch of the ice maker and the earth leakage breaker, and disconnect the power plug from the outlet.
- Choking hazard
 - After performing maintenance and repair, make sure that all components (such as fixtures, screws, bolts, etc.) are completely assembled.
 - Be careful not to let any components fall into the ice making compartment and ice reservoir.

Maintenance schedule

※ The following maintenance schedule is guideline.

※ Maintenance and repair should be done more frequently according to water quality, equipment usage environment and local hygiene regulations.

| Inspection Schedule | Area | Contents |
|---------------------|--|---|
| Daily | Chute | 1. Clean the ice chute with a neutral detergent. 2. Rinse thoroughly after cleaning. |
| Weekly | Air Filters (air-cooled) | 1. Inspect for dust and wash dirt with warm water and neutral detergent. |
| Monthly | External water filter | 1. Make sure that the pressure is adequate and make changes if needed. |
| | Outside of the ice maker | 1. Wipe it with a clean, soft cloth, and use a cloth dampened with a neutral detergent to wipe away any accumulated dust or grease. 2. Clean the chlorine dye (green spots) with non-abrasive detergent. |
| | The bottom of the ice maker | 1. Wipe clean with clean cloth and warm water. |
| Every six months | Ice maker and reservoir | 1. Clean and disinfect according to the disinfection instructions given in the instruction manual. |
| | Evaporator condensate drain pan and Geared motor drain pan | 1. Wipe clean with clean cloths and warm water, and slowly pour a cup of disinfectant solution (prepared as described in the instructions for disinfection in the manual) into the evaporator condensate drain pan. 2. Take care not to overflow the drain pan. 3. This disinfectant solution will flow out through the geared motor drain pan and drain passage. 4. Rinse repeatedly with a glass of clean water. |
| | Ice maker and reservoir | 1. Always check that it is kept clean. |
| | Ice exit fixing seal bolt | 1. Check for leaks around the seal bolt. Tighten if necessary and replace O-rings. 2. Always replace the O-ring when loosening the seal bolt and tighten it again. If there is no O-ring, apply Loctite 243 or equivalent fixing agent so that it does not leak. |
| Every year | Water supply valve and Drain valve | 1. Close the shutoff valve to shut off the water supply line and drain the water. 2. Close the shutoff valve to shut off the water supply line and drain the water. |
| | Water hose | 1. Check the water hose and clean it if necessary. |
| | Condenser (air-cooled) | 1. Inspect for cleaning, if necessary, clean with a brush or vacuum cleaner 2. If the dust adhesion is severe, spray the pin cleaning agent, clean the dust, spray it with clean water, rinse and dry with air gun. |
| | Ice maker | 1. Inspect for oil marks, loose components, tightening parts and wires. |
| | Upper bearing (ice exit head) | 1. Check that 0.02" round bar or pin gauge (or clearance gauge) is inserted into auger and bearing clearance, and replace all upper and lower bearings (ice exit head and lower housing) (Paid service) |
| | Mechanical seal | 1. Check for leaks in the bottom housing, and if there is a leak, disassemble the auger to replace the mechanical seal. (Paid service) (Water with a lot of calcium will shorten the life of replacement parts.) |
| Every three years | Upper and lower bearings, Housing O-ring, Mechanical seals, Evaporator cylinder, Auger | 1. Please check. If the auger and bearing clearance exceeds the factory recommended value (0.02" or less), replace both the upper and lower bearings. If the contact surface of the mechanical seal is worn, cracked, or scratched, replace it. |

Cautions for cleaning the external panel(stainless steel)

※ How to remove rust

How to clean rusted parts

1. Rust spots in early stage

- Rust spots in early stage mean that the stainless steel itself is not severely affected, thus mild detergent or any commercially available cleaning agent will restore original state. Rust will be removed with ease and at low cost if regular cleaning is done at appropriate intervals.

2. Red rust

- Rust spots that are not removed after a short period of time will turn into thick reddish–brown rust and will damage the surface of the stainless steel. These are much harder to remove and the surface will not be fully restored; thus, it is important to remove rust spots early on.

If commercially available cleaning agents do not work, use sandpaper or a stainless steel brush to remove the rust before applying the agent for easier removal.

This process requires treatment, such as refurbishment after cleaning.

3. Rust from iron

- Rust from coming into contact with welding spatter, rust from the metal bar above the stainless steel part, or contact between the stainless steel parts and general metal parts are caused galvanic corrosion. This causes the metal to rust first, and it will eventually cause the stainless steel to rust too if it is not removed. As such, make sure to clean and remove rust immediately with a mild detergent. However, when the rust has gotten really bad, it must be removed with 15% nitric acid solution or commercially available stainless steel cleaner.

4. Rust from exhaust gas or acid rain

- In environments, such as a factory complex or heavy transport sites, the product will become contaminated in a short amount of time due to exhaust fumes or acid rain and rust spots will quickly form. Light rust can be washed off with a mild detergent or soapy water, but heavy rust will require 15% nitric acid solution or commercially available stainless steel cleaner.

5. Rust from salt deposit

- In environments, such as windowsills or pipes on the porches of an apartment complex, that are close to the seashore where the product may be directly exposed to the sea winds, STS304 or STS316 will get rusted in no time, and this will occur much faster than in other types of environments. These cases require special treatment, such as using painted stainless steel or regular cleaning.

6. Rusts from disinfectants or cleaning agents

- Sites, such as pools or public baths, that use chlorine–based agents to sterilize the water, especially those for cleaning bathrooms, contain chlorine content that attaches to and rusts the stainless steel surface. Thus, it is important to thoroughly wash off such agents after using them, and a 15% nitric acid solution or commercially available stainless steel cleaner are required for removing this type of rust.

How to clean and disinfect

※ The ice maker should be cleaned and disinfected at least twice a year.
More frequent cleaning and disinfection may be required.



◆ Make sure to comply with the following.

- Do not use ammonia-based detergent to prevent damage to the personnel or the ice maker itself.
- Cleaning and sterilizing must be conducted in accordance with the instructions on the user manual.
- Always wear protective gloves and goggles to prevent skin or eye from coming into contact with the sterilizing solution.
- Do not use the ice made with the cleaning or sterilizing solution after cleaning and sterilizing.
Make sure that no sterilizing solution is left on any part of the ice maker and the ice storage bin.

1. Washing solution

Use a scale remover that is not harmful to human body by diluting with water, and use more amount if necessary.

It is important to use the diluted cleaning solution immediately for safety and maximum effect.

2. Washing procedure

- 1) Shut off the water supply by locking the valve of the water line of the ice maker.
- 2) Switch the ICE MAKING-OFF-WASH switch to the "WASH" position.
- 3) The water in the water tank is drained through the evaporator cylinder and washing is done by this (max. 5 minutes).
- 4) Turn the ICE MAKING-OFF-WASH switch to "OFF" position.
- 5) Remove all ice from the ice maker and reservoir.
- 6) Pour the wash solution into the wash solution inlet until the evaporator assembly and the water tank are full.
(Until the wash solution overflows to the drain box)
- 7) Leave the ice maker for 10 minutes before starting operation. If the water supply hose is clogged in step 7, remove it before operation.
- 8) As described below, please disassemble and clean the water level sensor (high and low) if it is in bad water condition.
If not, proceed to step 9.
 - Ⓐ Remove the water level sensor from the water tank cover.
 - Ⓑ Clean the level sensor with washing solution.
 - Ⓒ Wash the water level sensor thoroughly with clean water.
 - Ⓓ Fix the level sensor to the correct position.
- 9) Switch the ICE MAKING-OFF-WASH switch to the "ICE MAKING" position to start the ice maker. Keep it running until ice making stops. (※ Water supply valve should be locked so that water is not supplied.)
- 10) Switch the front ICE MAKING-OFF-WASH switch to the "WASH" position, and drain the remaining water in the water tank and evaporator cylinders for 5 minutes.
- 11) Switch the ICE MAKING-OFF-WASH switch to the "OFF" position.
- 12) Open the water supply valve of the ice maker, and switch the ICE MAKING-OFF-WASH switch to the "ICE MAKING" position so that water can be supplied to the water tank.
- 13) When the geared motor is activated, switch the ICE MAKING-OFF-WASH switch to the "WASH" position and drain the water (drain is possible for 5 minutes).
- 14) Turn OFF the power switch and disconnect the power cord from the outlet.

3. Disinfection wash

Dilute 10 L of warm water and 400 mL of 5.25% sodium hypochlorite solution (bleach).

(※ Dilution ratio may vary depending on the solution manufacturer, please refer to the solution manual).

If this is the minimum amount to be used, use more washing solution.

※ To ensure safety and maximum effect, please use the washing solution immediately after dilution.

4. Disinfection procedure – initial

- 1) Shut off the water supply by closing the valve of the water supply line and make sure that the power switch is turned to “OFF” position and the power plug is disconnected from the outlet, and then remove the front panel and the upper panel.
- 2) Pour the disinfectant solution over the water inlet until the evaporator assembly and the water tank are full.
(Until the disinfecting solution overflows to the drain box)
- 3) Open the top cover and disassemble the ice reservoir lid.
- 4) Disassemble packing, bush, etc. inside the lid.
- 5) Turn the Agitator to the left to disassemble it.
- 6) Remove the Ice Base Plate.
- 7) Disinfect the inside of the reservoir and the removed parts for 10 minutes and wipe them.
- 8) Remove Spout, clean for 10 minutes and wipe.
- 9) Please thoroughly rinse all parts with clean water. (※ If there is residual washing solution, it will cause corrosion.)
- 10) Assemble all parts in the correct position.
- 11) Connect the power plug to the outlet, turn the power switch to “ON” , turn the ICE MAKING–OFF–WASH switch to “ICE MAKING” and keep the operation until the disinfectant solution is exhausted and the ice production stops.
- 12) Switch the ICE MAKING–OFF–WASH switch to the "WASH" position and let the remaining water drain out for 5 minutes.
- 13) Turn the power switch to “OFF” and disconnect the power plug from the outlet.

5. Disinfection procedure – final

- 1) Mix the disinfection solution in a new bowl.
- 2) Check that the water valve is closed, the power switch is turned off and the power plug is disconnected from the outlet, and then remove the front panel and the upper panel.
- 3) Pour the disinfectant solution over the water inlet until the evaporator assembly and the water tank are full.
(Until the disinfecting solution overflows to the drain box)
- 4) Leave the ice maker for 10 minutes before operating the ice maker.
- 5) Connect the power plug to the outlet, turn on the power switch, and turn the ICE MAKING–OFF–WASH switch to 'ICE MAKING' until the disinfectant solution is exhausted and the ice stops generating.
- 6) Switch the ICE MAKING–OFF–WASH switch to 'WASH' and drain the remaining water for 5 minutes.
- 7) Switch the ICE MAKING–OFF–WASH switch to 'ICE MAKING' and open the valve of the ice–maker water supply line so that water can be supplied to the water tank.
- 8) When the geared motor starts to operate, switch the ICE MAKING–OFF–WASH switch to the 'OFF' position.
- 9) Switch the ICE MAKING–OFF–WASH switch to 'WASH' and discharge the remaining water for 5 minutes.
- 10) Turn the ICE MAKING–OFF–WASH switch to 'ICE MAKING' position to generate ice for 30 minutes, then turn off the power switch.
- 11) Pour warm water into the ice reservoir to dissolve the ice and drain it. Use a neutral detergent to wash the reservoir. After washing, rinse thoroughly with clean water.

8. Circuit Diagram

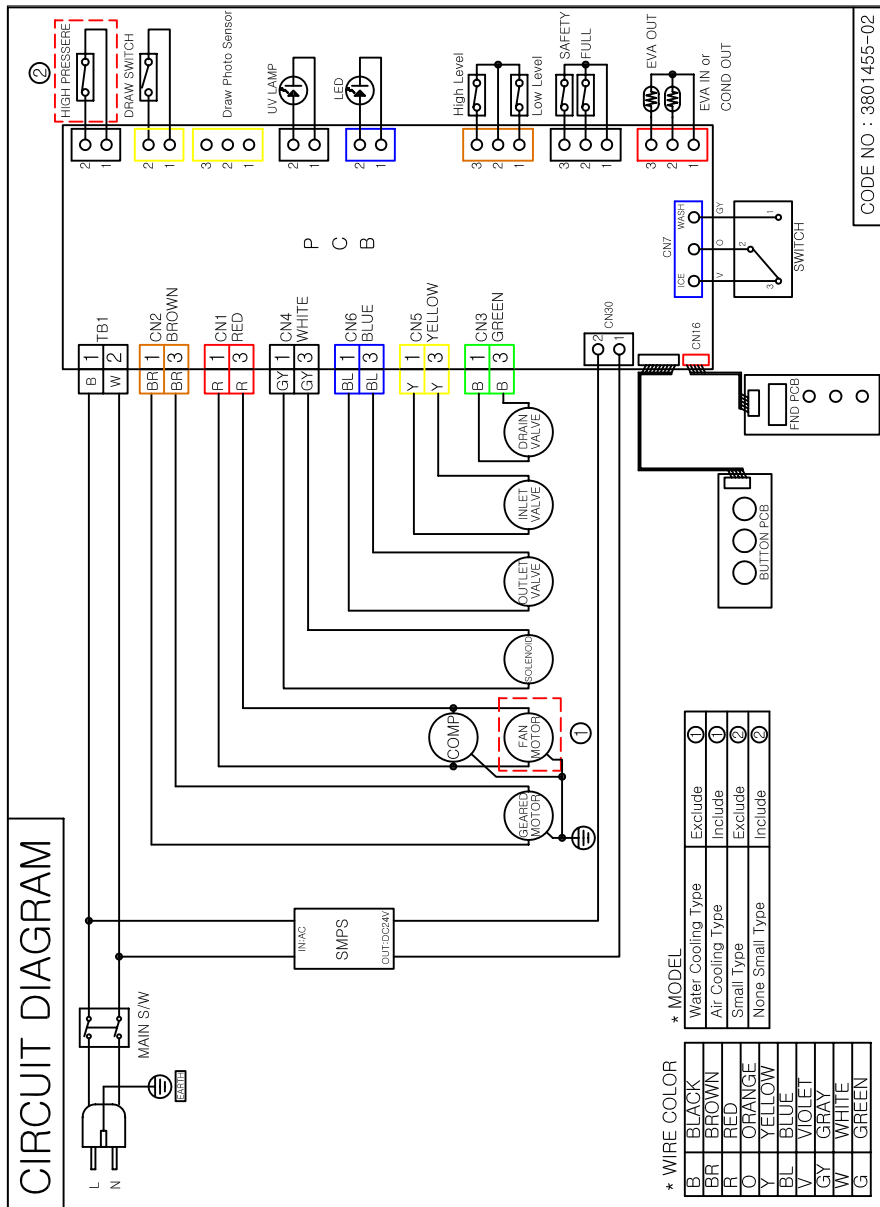

9. Error Type

- ① When Error occurs, the front use button (ICE–WATER–ICE & WATER) of the door lights alternately to the left and right. Restart after action.
- ② When the button is lit alternately to the left and right, open the door and press the bottom setting button of the control buttons, Error display will appear.

| Display | Error type | Causes | Action | Release | Operation |
|---------|------------------------------|--|---|--|--|
| Er01 | Evaporator temperature error | When the Evaporator temperature is 32°F or more after 30 minutes passed during the ice making | Check refrigerant leakage Check sensor and attachment abnormality | Resupply power after resolving cooling problem | Stop ice making |
| Er03 | Evaporator temperature error | When the Evaporator temperature is over 23°F after 30 minutes passed | Check refrigerant leakage Check sensor and attachment abnormality | Resupply power after resolving cooling problem | Keep on ice making |
| Er06 | Temperature sensor error | Displayed when temperature sensor is open or shorted. | Check sensor and attachment abnormality | Start operation after sensor part repair | Stop ice making |
| Er13 | High pressure switch error | Condenser dust, fan motor failure, cold cycle abnormality, etc. | Remove dust, Check Fan motor Check for abnormal cold cycle | Automatic return after action | Stop compressor, Stop motor after operating 10 seconds. |
| Er14 | High pressure switch error | Occurs when High pressure switch is OPEN 3 times or more | Contact service representative | Start operation after action | Stop compressor, Stop motor after operating 10 seconds. |
| Er15 | Water supply error | When water level is not detected by the water level sensor due to no water supply for 120 seconds. | Water supply pressure check Water level sensor check | Start operation after action | Stop ice making |
| Er16 | Water level sensor defect | At the start of ice making, when the upper and lower limits are not detected by the water level sensor for 60 seconds | Replacement of Water Level Sensor | Start operation after action | Stop ice making |
| Er25 | Motor restraint | Occurs when Evaporator inlet / outlet temperature is -4°F less Poor water supply, Agitator restraint, Ice jams due to scale | Unlock ice jams Check water supply line Check motor restraint fault | Start operation after action, Machine stops after 3 repetitions | Stop ice making |

10. Before Requesting Service

Make sure to check the following if the product is operated inappropriately. If the issue persists, contact the local distributor where you purchased the product or the customer service center.

Please provide the information on the warranty when you contact us.

(Model, serial number, name of distributor, date of purchase and detailed description of issue)

| Operational status | What to check | Measures |
|--|--|---|
| 1. Ice maker does not work | 1. Is power supplied? | Plug the power cord. |
| | 2. Is circuit breaker ON? | Turn on the circuit breaker on the back of the product. |
| | 3. Is the power supply of the machine using rating volts? | Check the power and make sure to use the proprietary plug. |
| | 4. Is the power switch on the front turned on? | Make sure to set the front power switch at 'ICE'. |
| 2. Water is not supplied. | 1. Is water valve closed? | Open the water valve. |
| | 2. Is water inlet hose installed properly? | Check and take necessary measures. |
| | 3. Is water working? | Check the water source. |
| | 4. Is water valve working? | Check and contact the customer service center. |
| 3. Takes too long to make ice cubes. | 1. Ice maker is too dirty(too much dust). (Air cooled type) | Disassemble the front cover, remove the dust filter and clean it with a vacuum cleaner. Too much dust deteriorates performance and may make the product use too much power. |
| | 2. Is ambient temperature not too high or low? | Operational temperature is 10°C ~ 38°C (50~100°F). Make sure that ambient temperature is appropriate. |
| | 3. Is the water inlet valve too clogged or has too much dreg? | Disassemble the valve and remove foreign objects from the filter. Make sure that the tap is closed for this. |
| 4. Ice maker is too noisy or makes strange noises. | 1. Is the floor level or solid enough? | Make sure that the floor is fully even. |
| | 2. Does either front or back of the ice maker come into contact with the wall? | There must be a gap wider than 50cm(19.7") from the walls. |
| | 3. Is supplied water too cold? | Water temperature needs to be 10°C~32°C (50~60°F). |
| | 4. Does the ice making device make too much noise? | Set the power switch to 'OFF', melt all ice and set the switch back to 'ICE'. Contact the customer service center. |

11. Product Warranty Period

If you did not receive or lost a warranty card or receipt, or if it is difficult to confirm the date of purchase due to other reasons, the warranty period will be calculated from 6 months after the date of manufacture.

[Free repair]

1. In the event of performance or functional failure occurring under normal use within the warranty period.

[Paid Repair]

1. Warranty expired products
2. If the product is not installed correctly at the initial stage of the delivered product and/or at the shop (customer) and re-installed
3. In case of installation due to movement of the product, moving, etc.
4. Failure due to defect of other company's product
5. If the fault occurred due to incorrect use of the electric capacity
6. In the case of malfunctions caused by consumables or options not specified by us
7. Failure or damage due to external impact or dropping
8. Failure due to natural disasters (lightning, fire, earthquake, flood, tsunami, etc.)
9. Consumable parts have reached end of life (packing, cleaning brush, etc.)
10. If the malfunction occurred by putting foreign substances into the product (water, drink, coffee, toy, etc.)
11. In case of product breakdown or malfunction due to external impact during installation and use
12. If the product malfunctions due to non-genuine parts or consumables
13. Failure due to failure to install according to the installation standards in the instruction manual.
14. If the customer disassembles the product and the accessories are lost or damaged.
15. If a person other than our engineer breaks down due to repair or modification of the product
16. If the malfunction occurred due to failure to observe the "Safety warnings and precautions" described in our instruction manual.
17. If the fault occurred due to freezing and clogging of the supply and drain pipes

MEMO



MEMO

We Think of Customer Satisfaction

MEMO



Online Internet Service
<http://www.icetro.com>

