



## Modular Bar Detail Specifications



Krowne Metal Corporation  
100 Haul Rd. Wayne, NJ 07470  
krowne.com

Where **passion** meets **precision.**™

# TYPICAL BAR DETAIL SPECIFICATION

## Typical Equipment Schedule

No.	Qty	Models	Description	Equipment Remarks
B00	23	KMB	Modular Bar Die System	
B100	1	KR18-T12	Underbar Dry Waste	
B101	1	KR18-MC12	Underbar Mixology Sink	
B102	1	KR18-MD8	Underbar Mixology Sink	
B103	1	KR18-ML12	Underbar Liquor Display	RS-42; KR-521
B104	1	KR18-30-10	Underbar Ice Chest	
B105	1	KR18-ME8	Underbar Ice Chest	
B106	1	KR18-4SH	Underbar Soda Gun Filler	
B107	1	KR18-GSB1	Underbar Glass Rack	RS-48
B108	1	KR18-43R	Underbar Sink	

## LED Lights & Outlets

Models	Description
KMB-LK-B	Cool Blue LED Light (1.5 Watts Output)
KMB-PS-25	25 Watt Power Supply for up to 10 LED Lights
KMB-PS60	60 Watt Power Supply for up to 25 LED Lights

## Tools Required for Installation

For proper installation, it is important to have the following tools on hand before starting the installation.

- Phillips head screw driver
- Level
- Tape measure
- Chalk line
- Power drill
- Shims for leveling
- 7/16 ratchet wrench
- 7/16 box wrench or adjustable wrench
- 1/4" x 7/16 hex head bolts and nuts (used for adjoining modular bar sections to each other).
- #8 Self starting galvanized screws (used for modular front panels & Anchoring to floor).

**Fasteners** are supplied in a plastic bag with your bar die.

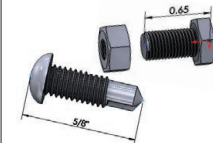

Make sure all screws are facing the same direction when adjoining modular sections for maintenance purposes.

## Mylar Template

Mylar template to be ordered prior to equipment going into production and is used to locate precise footprint of modular bar equipment. Template is to be sent in sections labeled A thru Z for ease of layout. Template allows for accurate marking of floor drain locations and beer/vent lines along with the added benefit of spatially visualizing your future bar. Mylar sections can be sent in up to 200" in length. Mylar template is optional and incurs an additional charge.

## Typical Bar Assembly Detail with Bar Die Wall

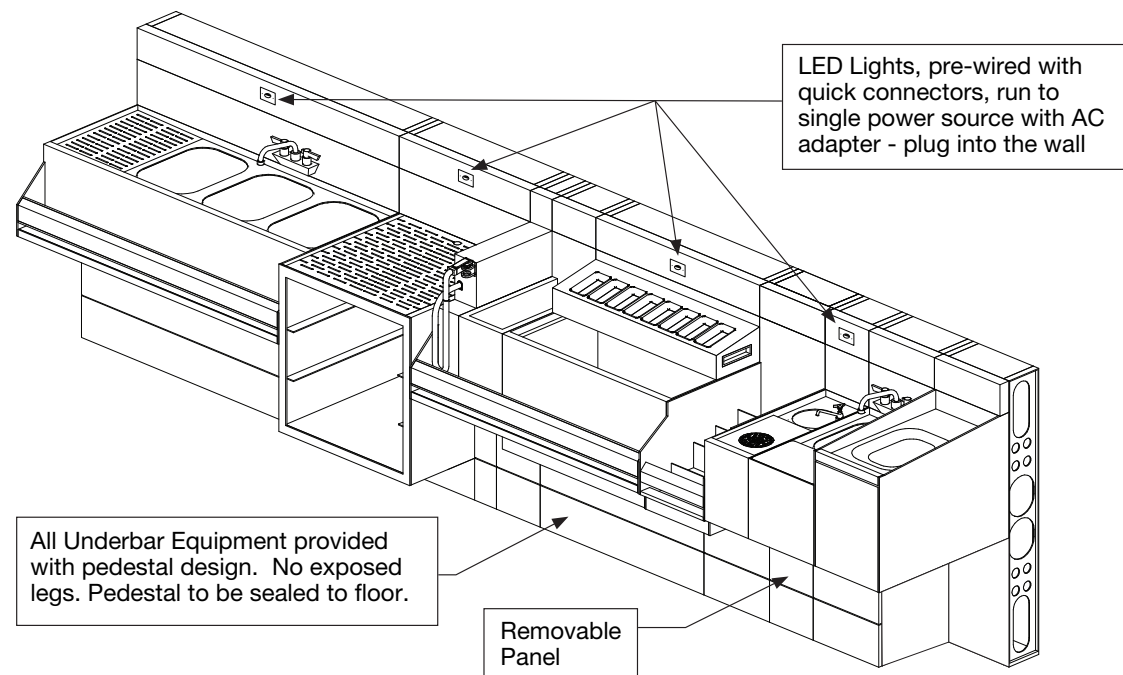
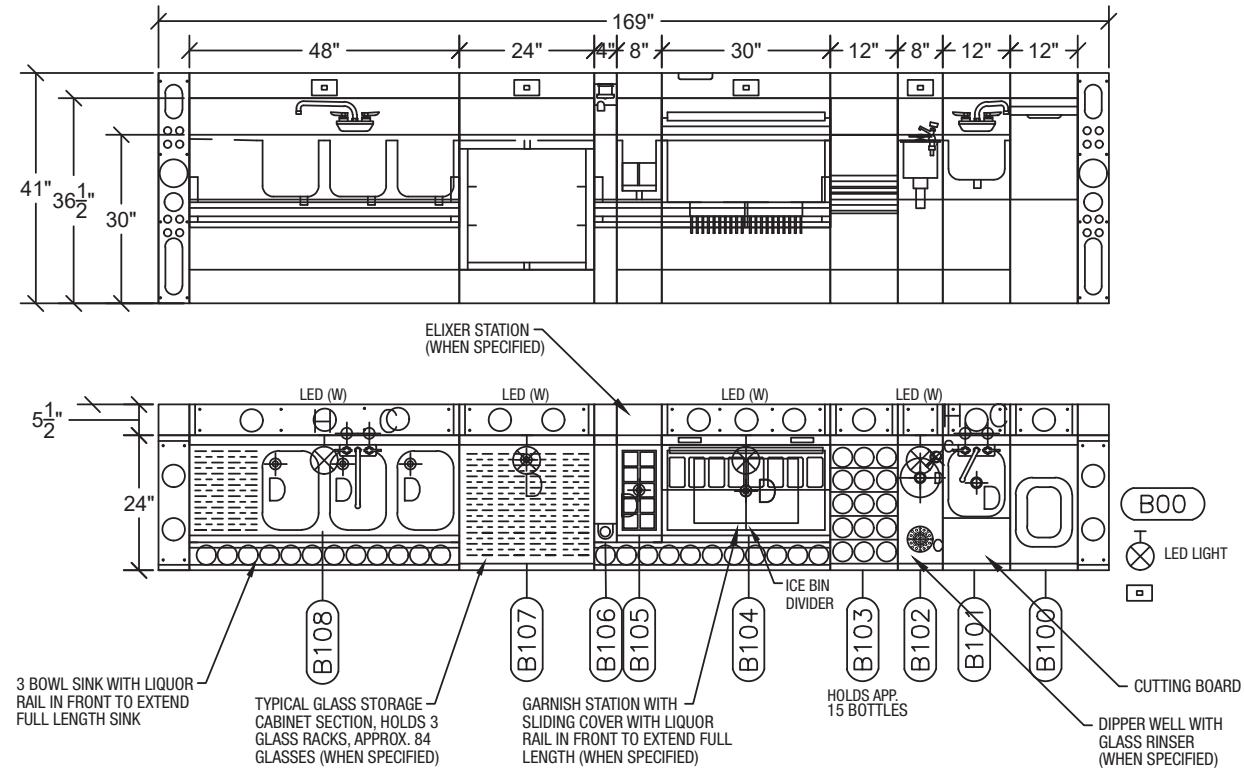

## Typical Bar Sections with Bar Die Wall Detail

\*Offset Bartop 2" with 36-1/2" Die Wall

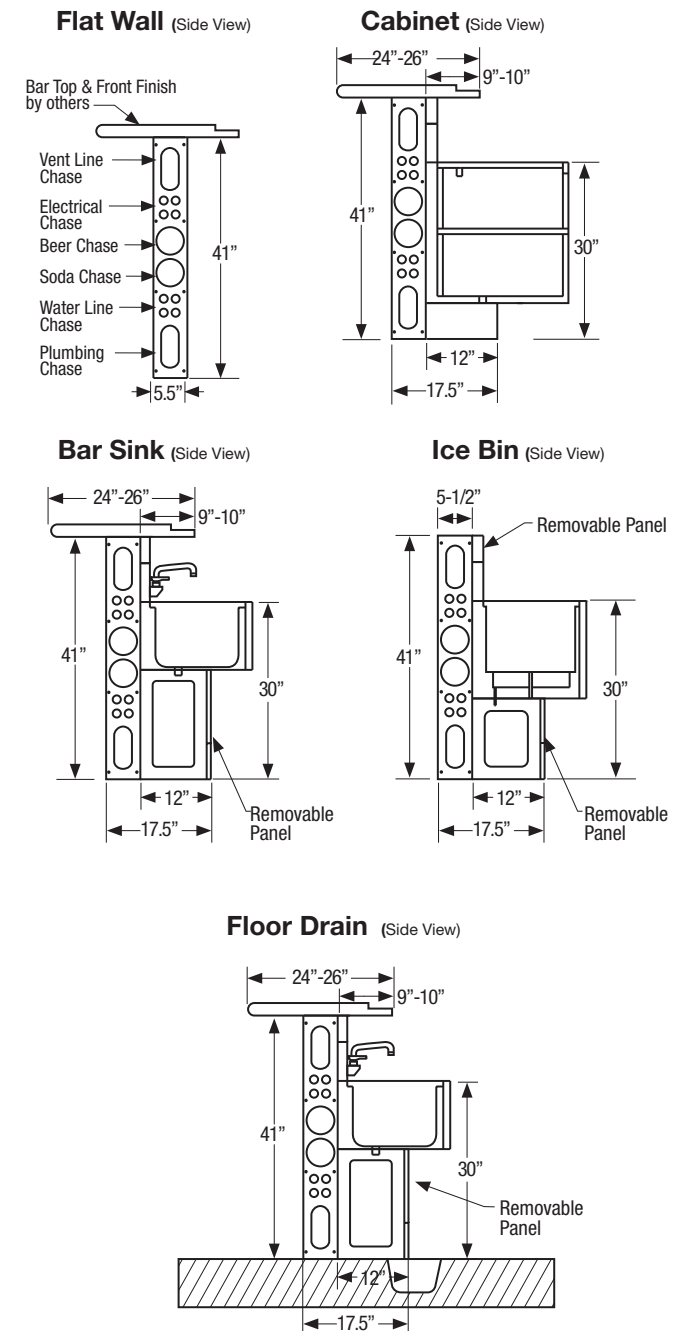

**Krowne Metal Corporation**  
100 Haul Road  
Wayne, NJ 07470  
krowne.com (800)631-0442

© 2019 Krowne Metal Corporation

Dealer		Approved By		Series	Mounting	Revisions		Project	
Krowne Metal Corporation				<input checked="" type="checkbox"/> Royal <input type="checkbox"/> Silver <b>Backsplash</b> <input checked="" type="checkbox"/> 6-1/2"H <input type="checkbox"/> 4"H	<input type="checkbox"/> Legs <input checked="" type="checkbox"/> Die Wall <b>Die Wall Height</b> <input type="checkbox"/> 41" Tall <input type="checkbox"/> 39-1/2" Tall	Desc.	Date		
Date:	Job #:	Approval Date:						Scale: 3/8" = 1'-0"	Page 2 of 4



# TYPICAL MILLWORK SPECIFICATION

## Millwork Installation

Install bar counter and removable front millwork panels. It is very important to have the front panels removable to allow access from the customers side for plumbing, electrical and beverage lines. Front panels use interlocking panels and hidden screws meaning they make accessing the underside of the bar very easy and the screws cannot be seen by customers.

Bar top and millwork panels to be provided by millwork fabricator and installed in the field after bar equipment is set. Food service equipment dealer to coordinate.

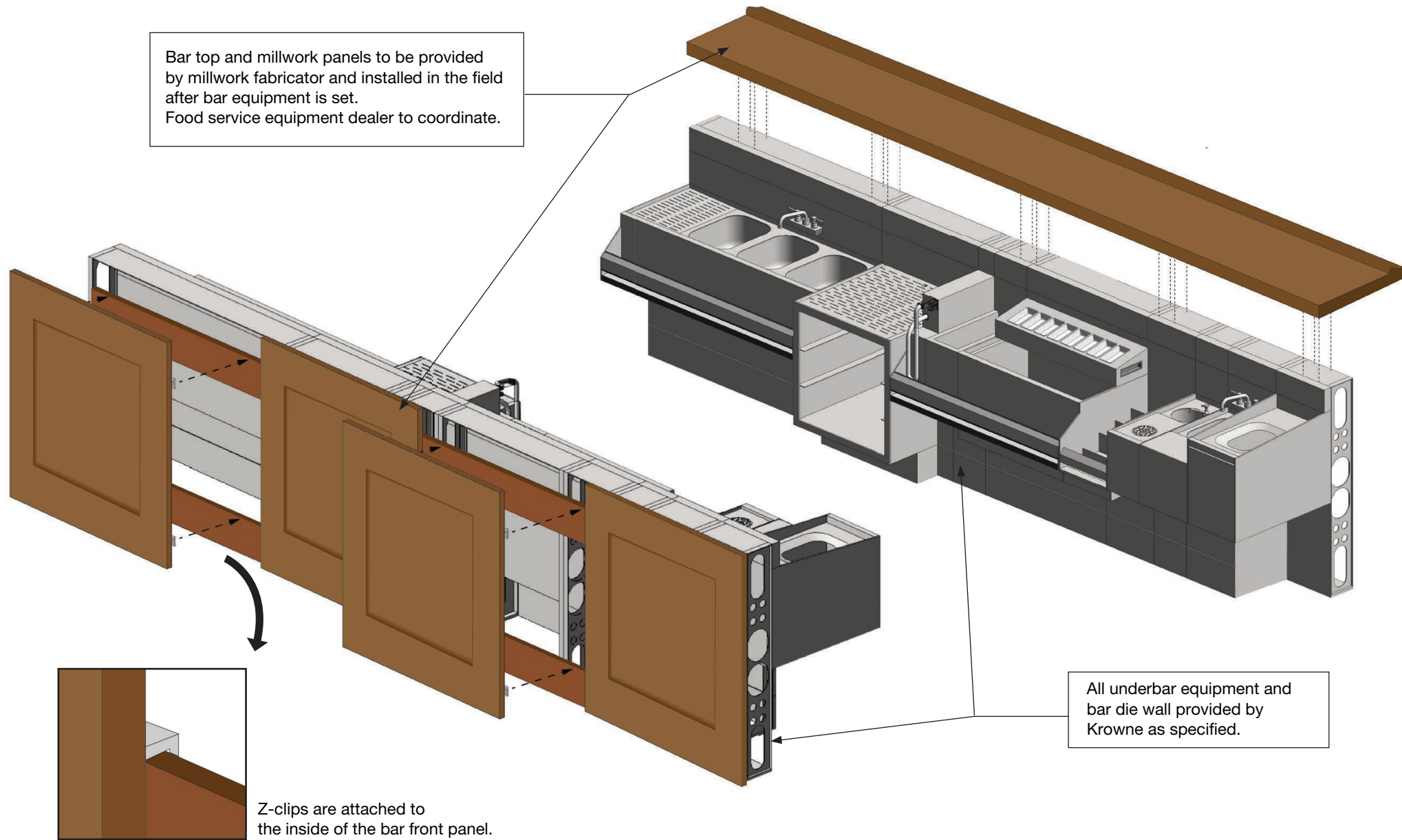

### METHOD A

Metal Z-clips are attached to the inside of the bar front panel. Z-clips (KMB-PC) available for purchase.



**Model KMB-PC**  
Stainless Steel Z-CLIPS  
with 3/4" offset (24 PACK)

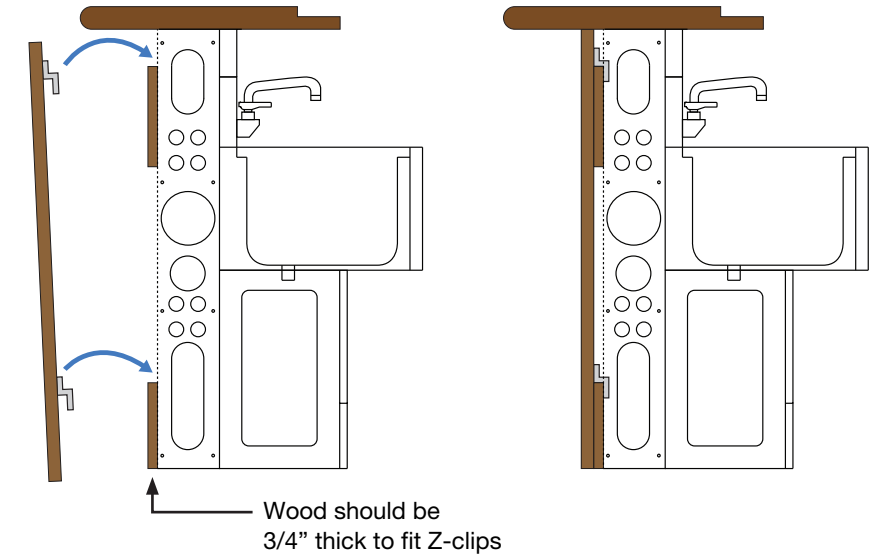

### METHOD B

Slide panel into channel created by two pieces of wood.

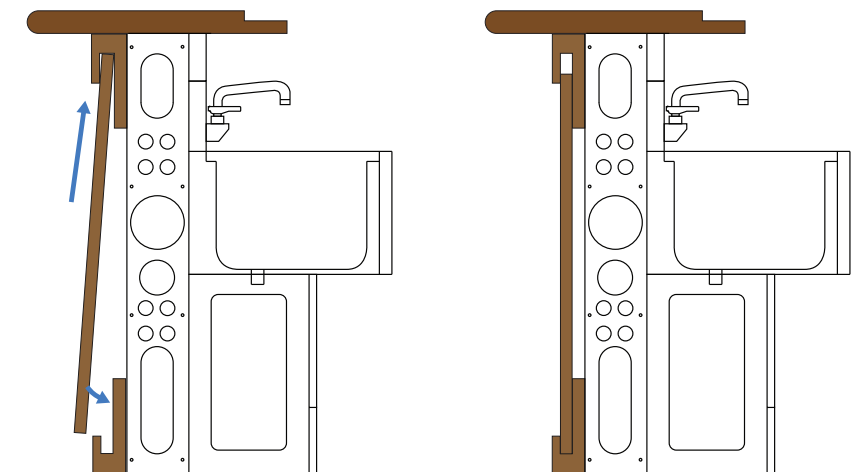

**Krowne Metal Corporation**  
100 Haul Road  
Wayne, NJ 07470  
krowne.com (800)631-0442

© 2019 Krowne Metal Corporation

Dealer		Approved By		Series	Mounting	Revisions		Project	
Date:	Job #:	Approval Date:		<input checked="" type="checkbox"/> Royal <input type="checkbox"/> Silver <b>Backsplash</b> <input checked="" type="checkbox"/> 6-1/2"H <input type="checkbox"/> 4"H	<input type="checkbox"/> Legs <input checked="" type="checkbox"/> Die Wall <b>Die Wall Height</b> <input type="checkbox"/> 41" Tall <input type="checkbox"/> 39-1/2" Tall	Desc.	Date	Scale: 3/8" = 1'-0"	Page 3 of 4

# TYPICAL DETAIL SPECIFICATION

## LED Light Specifications

<b>Models</b>	25 Watt Power Supply (KMB-PS-25) 60 Watt Power Supply (KMB-PS-60)	<b>Input Voltage</b>	9-30V DC, 9-15V AC
<b>Features</b>	No glare, down-angled beam Rugged and Waterproof Brushed Nickel Oval Bezel Includes stainless steel pre-punched wall plate, (1) 2" x 4" electrical box	<b>Input Power</b>	1.5 Watts Typ, 2.5 Watts Max
<b>Colors</b>	Cool Blue (KMB-LK-B)	<b>Lumens</b>	17 lms typ @3000 °K
		<b>IP Rating</b>	IP67
		<b>Wiring</b>	6" Twisted 18 AWG

### Wiring Example 12/24V DC No Dimming

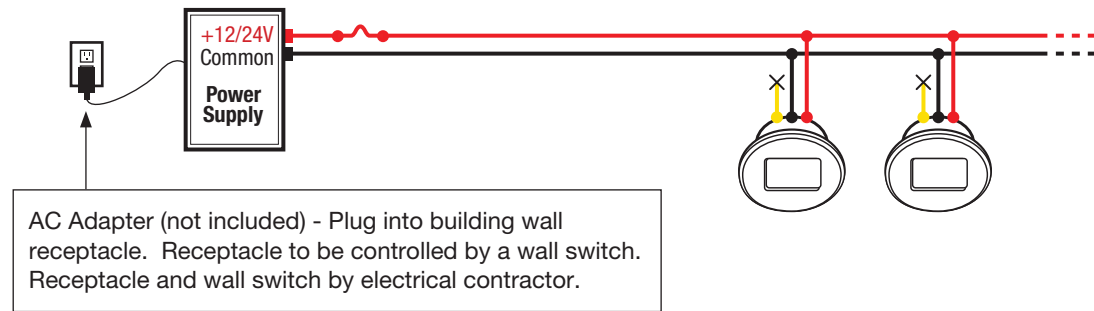

### Recommended Spot for LED power supply and switch on diagram:

The master switch location is determined by customer preference but we recommend not placing it near a sink and it must meet local district code. Follow these same guideless for the outlet location. The transformer should be installed in the back of the mod wall and it must be easily accessible by local district code. We would recommend having it plug into an outlet.

## Modular Bar Die Specifications

### Mechanical Specifications

**Utility lines:** Dedicated chase locations for hot/cold water supply lines, beverage line conduits, and electrical conduit (behind the underbar equipment) this chase is accessible from the floor and runs the entire length of the bar.

**Floor drains:** Locate floor drains directly below workboard equipment. The number of floor drains will vary depending on the bar layout and local codes.

### Utility Specifications

A 5-1/2" open zone is furnished behind the equipment to provide room for trunk lines, soda lines, plumbing, electrical, etc. To travel vertically or horizontally within the bar structure. Connections can be made from the front of the bar with panels removed.

### Plumbing Specifications

All water service and waste connections can be made from the front of the bar (decorative front panel removed). Local codes dictate installation (by others).

### General Specifications

**Structure:** Configured to the exact size and shape of underbar equipment, freestanding cabinets and openings, as specified.

**Chase:** Interior chase runs the entire length of the structure including corners.

### Electrical Specifications

All electrical requirements such as receptacle to blenders, washers, coolers, soda guns, light, etc. (by others).

## Modular Bar Die Chaseways

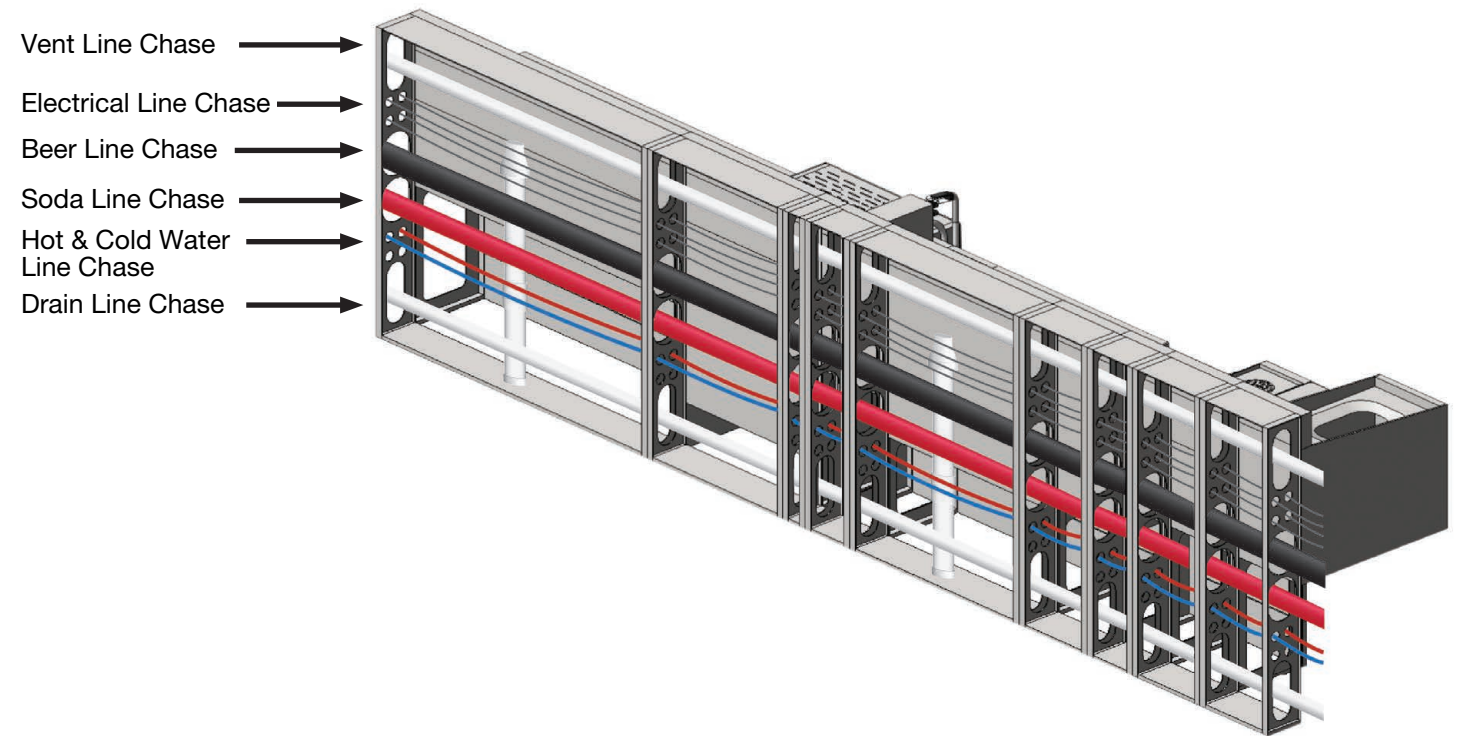

## Modular Bar Die Options

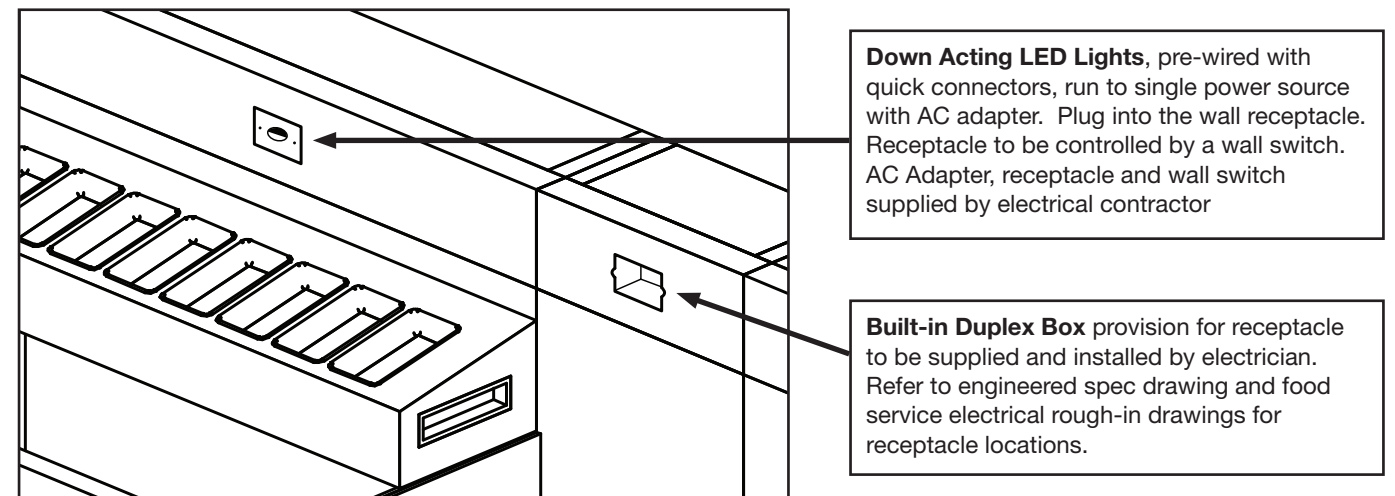

**Krowne Metal Corporation**  
100 Haul Road  
Wayne, NJ 07470  
krowne.com (800)631-0442

<b>Date:</b>	<b>Job #:</b>	<b>Approval Date:</b>	<b>Series</b> <input checked="" type="checkbox"/> Royal <input type="checkbox"/> Silver <b>Backsplash</b> <input checked="" type="checkbox"/> 6-1/2"H <input type="checkbox"/> 4"H	<b>Mounting</b> <input type="checkbox"/> Legs <input checked="" type="checkbox"/> Die Wall <b>Die Wall Height</b> <input type="checkbox"/> 41" Tall <input type="checkbox"/> 39-1/2" Tall	<b>Revisions</b>		<b>Project</b>	
					Desc.	Date		
					Scale: 3/8" = 1'-0"		Page 4 of 4	