



IMPORTANT FOR FUTURE REFERENCE  
Please complete this information and retain this  
manual for the life of the equipment:

Model #: \_\_\_\_\_

Serial #: \_\_\_\_\_

Date Purchased: \_\_\_\_\_

# Installation and Operation Manual

## Fryer Models

35C, 40S/C, 40D, 45C, 65C



## TO THE PURCHASER, OWNER AND STORE MANAGER

Please review these warnings prior to posting them in a prominent location for reference.

### TO THE PURCHASER

Post in a prominent location the instructions to be followed in the event that an operator smells gas. Obtain this information from your local gas supplier.

### FOR YOUR PROTECTION

DO NOT store or use gasoline or other flammable vapors or liquids in the vicinity of this or any other equipment. Do not spray aerosols in the vicinity of this equipment when it is in operation.

### WARNING

Improper installation, adjustment, operation, alteration, service or maintenance can cause property damage, injury or death. Read the installation, operating and maintenance instructions thoroughly before installing, operation, servicing this equipment.

### WARNING

Installation, maintenance and repairs should be performed by a Pitco Authorized Service and Parts (ASAP) company technician or other qualified personnel. Installation, maintenance or repairs by an unauthorized and unqualified personnel will void the warranty.

### WARNING

Installation and all connections must be made according to local codes in force. In the absence of local codes in North America, the installation must conform with the National Fuel Gas Code, ANSI Z223.1/NFPA 54 or the Natural Gas and Propane Installation Code CSA B149.1 as applicable. In Australia, the appliance must be installed in compliance with AS/NZS 5601.

### WARNING

During the warranty period if a customer elects to use a non-original part or modifies an original part purchased from Pitco and/or its Authorized Service and Parts (ASAP) companies, this warranty will be void. In addition, Pitco and its affiliates will not be liable for any claims, damages or expenses incurred by the customer which arises directly or indirectly, in whole or in part, due to the installation of any modified part and/or received from an unauthorized service center.

### WARNING

This appliance, when installed, must be electrically grounded in accordance with local codes, or in the absence of local codes, with the National Electrical Code, ANSI/NFPA 70, or the Canadian Electrical Code, CSA C22.2, as applicable and the hose must comply with AS/NZS 1869 and be class B or D.

### WARNING

Adequate means must be provided to LIMIT the movement of this appliance without depending on the gas or electrical cord connection. Single appliances equipped with legs must be stabilized by installing anchor straps. All appliances equipped with casters must be stabilized by installing restraining chains.

### WARNING

An appliance equipped with casters and a flexible gas line must be connected to the gas supply with a quick disconnect device. In North America, this quick disconnect must comply with ANSI Z24.41. In Australia, the quick disconnect must comply with AS 4627.

## **TO THE PURCHASER, OWNER AND STORE MANAGER**

**Please review these warnings prior to posting them in a prominent location for reference.**

### **WARNING**

**DO NOT** alter or remove structural material on the appliance to accommodate placement under a ventilation hood.

### **WARNING**

If the appliance is equipped with a power cord and it is damaged, it must be replaced by a Pitco Authorized Service and Parts (ASAP) company technician, or a similarly qualified person in order to avoid a hazard.

### **WARNING**

The power supply must be disconnected before servicing, maintaining or cleaning this appliance.

### **WARNING**

The appliance is **NOT** jet stream approved. **DO NOT** clean the appliance with a water jet.

### **WARNING**

**DO NOT** attempt to move this appliance or transfer hot liquids from one container to another when the unit is at operating temperature or filled with hot liquids. Serious personal injury could result if skin comes in contact with the hot surfaces or liquids.

### **WARNING**

**DO NOT** use an open flame to check for gas leaks!

### **WARNING**

**DO NOT** sit or stand on this appliance. The appliance's front panel, tank, splash back, tank cover, workshelf, drain board is not a step. Serious injury could result from slipping, falling or contact with hot liquids.

### **WARNING**

**NEVER** use the appliance as a step for cleaning or accessing the ventilation hood. Serious injury could result from slips, trips or from contacting hot liquids.

### **WARNING**

The oil/shortening level should **NOT** fall below the minimum indicated level line at any time. The use of old shortening can be dangerous as it will have a reduced flash point and be more prone to surge boiling.

### **WARNING**

The contents of the crumb catch and/or filter pan of any filter system must be emptied into a fireproof container at the end of the frying operation each day. Some food particles can spontaneously combust into flames if left soaking in certain oil/shortening materials.

### **WARNING**

Completely shut the appliance down when oil/shortening is being drained from the appliance. This will prevent the appliance from heating up during the draining and filling process. Serious injury can occur.

### **WARNING**

This appliance is intended for indoor use only.

### **WARNING**

**DO NOT** operate appliance unless all panels and access covers are attached correctly.

### **WARNING**

It is recommended that this appliance be inspected by a qualified service technician for proper performance and operation on a yearly basis.

## **TO THE PURCHASER, OWNER AND STORE MANAGER**

**Please review these warnings prior to posting them in a prominent location for reference.**

### **WARNING**

There is an open flame inside this appliance. The unit may get hot enough to set nearby materials on fire. Keep the area around the appliance free from combustibles.

### **WARNING**

**DO NOT** supply the appliance with a gas that is not indicated on the data plate. If you need to convert the appliance to another type of fuel, contact your dealer.

### **WARNING**

If gas flow to appliance is interrupted, or pilots extinguish, wait 5 minutes before attempting to relight the pilot to allow any residual gas in appliance to dissipate.

### **WARNING**

Ensure that the appliance can get enough air to keep the flame burning correctly. If the flame is starved for air, it can give off a dangerous carbon monoxide gas. Carbon monoxide is a clear odorless gas that can cause suffocation.

### **WARNING**

Never add oil to the appliance when it is at operating temperature. Splashing hot oil can cause severe injuries.

### **WARNING**

Never add water to hot oil. Violent boiling can occur causing severe injury.

### **WARNING**

This appliance is intended for professional use only and should be operated by fully trained and qualified personnel.

### **WARNING**

To avoid splashing of hot liquid when installed, this fryer must be restrained either in the manner of installation, or with adequate ties to prevent tipping.

### **WARNING**

In North America, gas appliances equipped with casters must be installed with connectors that comply with the Standard for Connectors for Movable Gas Appliances, ANSI Z21.69.CSA 6.16 Latest Edition. This connection should include a quick disconnect device that complies with the Standard for Quick Disconnect Devices for Use with Gas Fuel ANSI Z21.41.CSA 6.9 Latest Edition.

### **WARNING**

In Australia, an appliance equipped with casters and a flexible gas line must be connected to the gas supply with a quick disconnect device that complies with AS 4627 Latest Edition and a restraining cable. The restraining cable must not exceed 80% of the length of the flexible gas line.

### **WARNING**

This appliance is not intended for use by a person (including children) with reduced physical, sensory or mental capabilities, or lack of experience and knowledge, unless they have been given supervision or instruction concerning use of the appliance by a person responsible for their safety. Children should be supervised to ensure that they do not play with the appliance.

### **WARNING**

Children should not be in the vicinity of this appliance when it is being operated, cleaned, maintained or serviced nor allowed to play on and/or with the appliance at any time.

|   |           |
|---|-----------|
| <b>1. INSTALLATION .....</b>  | <b>6</b>  |
| 1.1. CHECKING AND UNPACKING YOUR NEW APPLIANCE .....                | 6         |
| 1.2. INSTALLATION CLEARANCES .....                                  | 6         |
| 1.3. LEVELING THE APPLIANCE – LEGS/CASTERS.....                     | 7         |
| 1.4. HEAT DEFLECTOR INSTALLATION .....                              | 9         |
| <b>2. GAS CONNECTION .....</b>                                      | <b>9</b>  |
| 2.1. GAS SUPPLY TO THE APPLIANCE.....                               | 9         |
| 2.2. QUICK DISCONNECT CONNECTION .....                              | 10        |
| 2.3. FUEL SUPPLY LINE LEAK AND PRESSURE TESTING.....                | 10        |
| 2.4. INSTALLATION SETUP .....                                       | 10        |
| 2.5. VENTILATION AND FIRE SAFETY SYSTEMS.....                       | 10        |
| 2.6. INSPECTION .....   | 11        |
| 2.7. INITIAL ADJUSTMENTS .....                                      | 11        |
| 2.7.1. FILLING THE APPLIANCE FOR ADJUSTMENT & INITIAL CLEANING..... | 11        |
| 2.7.2. LIGHTING INSTRUCTIONS .....                                  | 12        |
| 2.7.3. PILOT FLAME ADJUSTMENT.....                                  | 13        |
| 2.7.4. BURNER SYSTEM ADJUSTMENT.....                                | 13        |
| 2.8. INITIAL CLEANING.....  | 14        |
| <b>3. OPERATION .....</b>   | <b>15</b> |
| 3.1. FILLING THE COOK TANK .....                                    | 15        |
| 3.2. FILLING THE COOK TANK WITH LIQUID OIL/SHORTENING.....          | 15        |
| 3.3. FILLING THE TANK WITH SOLID OIL/SHORTENING .....               | 16        |
| <b>4. APPLIANCE START UP .....</b>                                  | <b>17</b> |
| 4.1. COOKING .....  | 18        |
| 4.2. COOKING TIPS .....   | 18        |
| <b>5. APPLIANCE SHUTDOWN .....</b>                                  | <b>18</b> |
| 5.1. STANDBY MODE .....   | 18        |
| 5.2. COMPLETE SHUTDOWN .....  | 18        |
| <b>6. PREVENTATIVE MAINTENANCE .....</b>                            | <b>18</b> |
| 6.1. DAILY PREVENTATIVE MAINTENANCE.....                            | 18        |
| 6.1.1. DAILY CLEANING .....   | 19        |
| 6.1.2. APPLIANCE INSPECTION.....                                    | 19        |
| 6.1.3. CLEANING THE COOK TANK .....                                 | 19        |
| 6.1.4. CLEANING THE CABINET .....                                   | 19        |
| 6.2. WEEKLY PREVENTATIVE MAINTENANCE .....                          | 20        |
| 6.3. MONTHLY PREVENTATIVE MAINTENANCE .....                         | 20        |
| 6.3.1. BOIL OUT PROCEDURE.....                                      | 20        |
| 6.4. ANNUAL/PERIODIC PREVENTATIVE MAINTENANCE AND INSPECTION.....   | 21        |
| 6.4.1. SAFETY EVALUATION .....                                      | 21        |
| 6.4.2. MECHANICAL INSPECTION.....                                   | 21        |
| 6.4.3. TEMPERATURE CONTROL SYSTEM .....                             | 21        |
| 6.4.4. GAS COMBUSTION SYSTEM .....                                  | 21        |
| 6.5. VENTILATION HOOD.....  | 22        |
| 6.6. THERMOSTAT CALIBRATION CHECK.....                              | 22        |
| <b>7. TROUBLESHOOTING .....</b>                                     | <b>23</b> |
| 7.1. HIGH TEMPERATURE LIMIT SWITCH .....                            | 23        |
| 7.2. MILLIVOLT WIRING DIAGRAMS.....                                 | 23        |
| 7.3. TROUBLESHOOTING CHARTS .....                                   | 24        |

# 1. INSTALLATION

## 1.1. CHECKING AND UNPACKING YOUR NEW APPLIANCE

Your new Pitco appliance has been carefully packed into one crate. Every effort has been made to ensure that it is delivered to you in perfect condition. Pitco does not assume responsibility for damage or loss incurred in transit.

1. Upon Delivery, inspect for visible shipping damage in the presence of the trucking operator. If something appears damaged, file a claim for damages regardless of extent.
2. Unpack and inspect unit for damage. Contact the shipper within 15 days and file a concealed damage claim; the shipper is only responsible for concealed damage for 15 days after delivery.
3. Remove the unit from the shipping pallet:
4. Do not allow the full weight of the unit to rest on the legs or caster (if installed) when removing the appliance from the shipping pallet. The casters can be bent or damaged if too much weight or force is applied to them from improper handling.
5. Check the packing list enclosed with your appliance to ensure that you have received all the parts to the appliance. If you are missing any parts, contact the dealer from whom the appliance was purchased.
6. Using the front cover of this manual, record the following for warranty service or future reference:
  1. Your Pitco model number.
  2. Fryer serial numbers (Found on the inner door of each fryer).
  3. The date purchased from your dealer invoice.

Once you have completed the above, the appliance is ready to be installed.

## 1.2. INSTALLATION CLEARANCES

The clearances shown below are for combustible and non-combustible installations and will allow for safe and proper operation of your appliance.

|              | <b>Combustible Construction</b> | <b>Non-Combustible Construction</b> |
|--------------|---------------------------------|-------------------------------------|
|              | Inches (centimeters)            | Inches (centimeters)                |
| <b>Back</b>  | 6.0" (15.2 cm)                  | 0.0" (0.0 cm)                       |
| <b>Sides</b> | 6.0" (15.2 cm)                  | 0.0" (0.0 cm)                       |
| <b>Floor</b> | 9" (22.86 cm)                   | 9" (22.86 cm)                       |

In addition to the above clearances there must also be at least 30 inches (76.2 cm) of aisle space in front of the appliance.

|  |
|--|
| <b>WARNING</b>   |
| <b>Leave at least 18 inches (47 cm) of open space between the flue of the appliance and the intake of the exhaust hood. Failure to do so could result in improper operation of the appliance.</b>  |
| <b>WARNING</b>   |
| <b>DO NOT obstruct the flow of ventilation air openings around the appliance. Adequate clearance around the appliance is necessary for servicing and proper component ventilation. Ensure that you meet the minimum clearance requirements specified in this manual.</b>                       |
| <b>WARNING</b>   |
| <b>DO NOT install this appliance next to a water cooker, or use it in any way in which water can come in contact with the hot oil. Splash over of water into hot oil may result in a steam eruption, potentially causing hot oil to be ejected from the fryer, and creating a burn hazard.</b> |

**1.3. LEVELING THE APPLIANCE – LEGS/CASTERS**

|  |
|--|
| <b>CAUTION</b>   |
| To prevent equipment damage and/or personal injury, do not tilt the appliance onto any two of its casters or legs, or pull the appliance by the splash back. |
| <b>WARNING</b>   |
| This appliance <u>must</u> be installed with the legs or casters provided by the manufacturer.   |
| <b>WARNING</b>   |
| <b>DO NOT</b> perform leveling procedure when appliance is in operation or full of hot liquids. Serious injury could result.                                 |

When you receive your appliance, it is completely assembled with the possible exception of legs or optional casters and heat deflector.

This appliance must be installed with legs or casters; it cannot be curb mounted, or sealed to a base. Curb mounting will seriously inhibit this appliance’s ability to effect proper component ventilation. The supplied legs or casters provide the necessary height to meet sanitation requirements and assure adequate air supply for electrical component ventilation. To level the appliance, use the following procedure.

Required tools: Large pair of water pump pliers, Medium flat blade screwdriver, level 12” (30.5 cm) long max.

- 1 Position appliance in final installed location.
- 2 Apply level across front, and then the left and right side of unit, determine lowest point, and distance to level.
- 3 Add the distance determined in step 2 to caster or leg on the lowest corner of appliance.
  1. Swivel casters- loosen 2 set screws (A)
  2. Legs and swivel casters-. Adjust the height of the leg / caster by turning adjustment collar/ foot (B) with water pump pliers until desired change in height is achieved.  
Swivel casters only: Retighten set screws (A).
  3. Fixed casters- Adjust height by moving wheel and axle to alternate holes (D) in wheel bracket higher or lower as needed. Refer to “FIXED” type caster in Figure 3.
- 4 Adjust remaining casters or legs as needed to ensure the appliance is supported evenly at each caster/leg contact point.

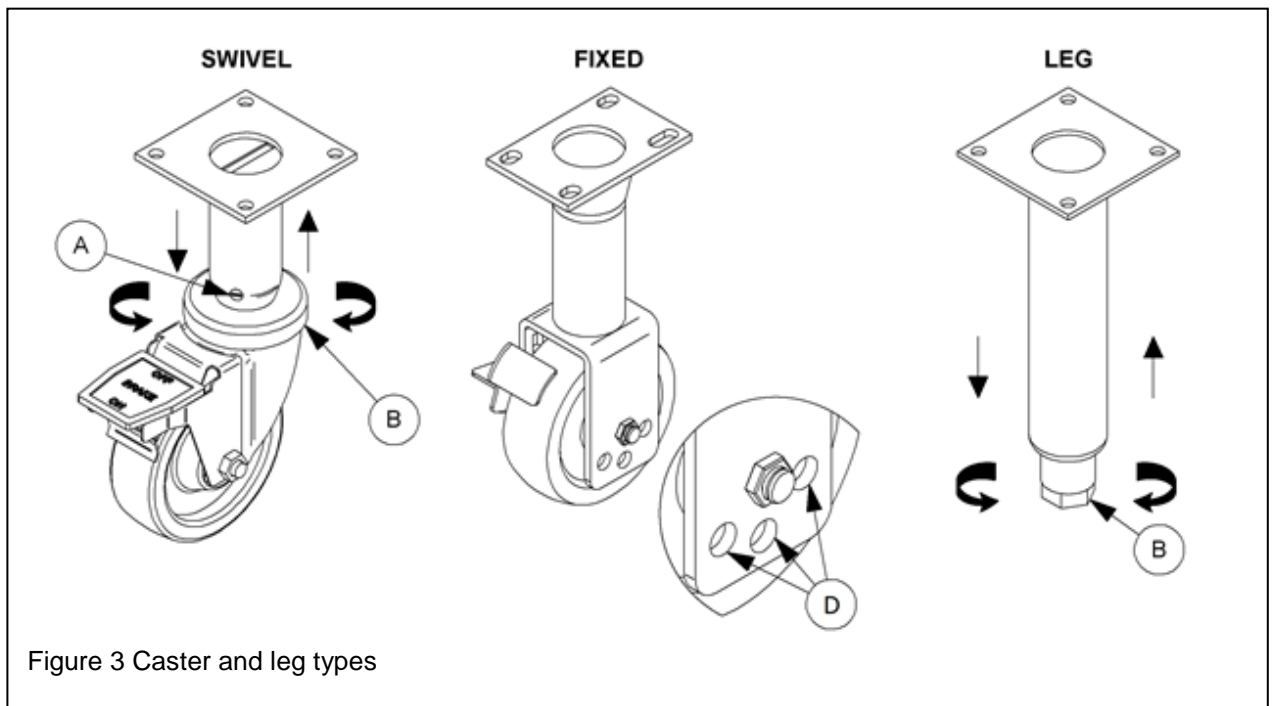

**CE GAS TABLE**

Refer to the following table for gas specifications for the country of use. If the country of use is NOT listed, refer to the information printed on the data plate.

| Applicable Countries  | Model | Fuel Type     | Gas                                | Appliance Category | Gross Input (kW) | Net Input (kW) | Supply Pressure (mbar) | Burner Pressure (mbar) | Burner Orifice | Pilot Orifice (code) | Governor | Nominal Gas Rate (m <sup>3</sup> /hr) |                |         |         |
|---|-------|---------------|------------------------------------|--------------------|------------------|----------------|------------------------|------------------------|----------------|----------------------|----------|---------------------------------------|----------------|---------|---------|
| AT, BG, CH, CZ, DK, EE, FI, GB, GR, HR, HU, IE, IT, LT, LV, NO, PL, PT, RO, ES, SI, SK, SE, TR  | 35C   | Nat           | G20                                | I <sub>2H</sub>    | 26               | 23.4           | 20                     | 10                     | 2.44 mm        | N22                  | YES      | 2.5                                   |                |         |         |
| I <sub>2E</sub>   |       |               |                                    | 20/25              |                  |                |                        |                        |                |                      |          |                                       |                |         |         |
| G20/G25   |       |               | I <sub>2E+</sub>                   |                    |                  |                | 25                     |                        |                |                      | 2.58 mm  | YES                                   | 2.9/2.8        |         |         |
|   |       |               | I <sub>2ELL</sub>                  |                    |                  |                |                        |                        |                |                      |          |                                       |                |         |         |
| G25-G25.3   |       |               | I <sub>2L</sub> - I <sub>2EK</sub> | 37/50              |                  |                | 25.4                   |                        |                |                      | .0625"   | LP16                                  | NO             | 2.5/2.9 |         |
|   |       |               | I <sub>3P</sub>                    |                    |                  |                |                        |                        |                |                      |          |                                       |                |         |         |
| BE, BG, CH, CZ, DE, ES, FR, GB, GR, HR, HU, IE, IS, IT, LT, LU, LV, MK, MT, NL, PL, PT, RO, SI, | Pro   | G31           | I <sub>3P</sub>                    |                    |                  |                |                        |                        |                |                      |          | 1.0                                   |                |         |         |
| NOT AVAILABLE   | 40C   | NOT AVAILABLE |                                    |                    |                  |                |                        |                        |                |                      |          |                                       |                |         |         |
| NOT AVAILABLE   | 40D   | NOT AVAILABLE |                                    |                    |                  |                |                        |                        |                |                      |          |                                       |                |         |         |
| NOT AVAILABLE   | 45C   | NOT AVAILABLE |                                    |                    |                  |                |                        |                        |                |                      |          |                                       |                |         |         |
| AT, BG, CH, CZ, DK, EE, FI, GB, GR, HR, HU, IE, IT, LT, LV, NO, PL, PT, RO, ES, SI, SK, SE, TR  | 65C   | Nat           | G20                                | I <sub>2H</sub>    | 40               | 36.0           | 20                     | 10                     | 2.38 mm        | N22                  | YES      | 3.8                                   |                |         |         |
| I <sub>2E</sub>   |       |               |                                    | 20/25              |                  |                |                        |                        |                |                      |          |                                       | 2.38 / 2.58 mm |         |         |
| G20/G25   |       |               | I <sub>2E+</sub>                   |                    |                  |                | 25                     |                        |                |                      | 2.58 mm  | YES                                   |                | 4.4/4.3 |         |
|   |       |               | I <sub>2ELL</sub>                  |                    |                  |                |                        |                        |                |                      |          |                                       |                |         |         |
| G25-G25.3   |       |               | I <sub>2L</sub> - I <sub>2EK</sub> | 36.8               |                  |                | 37/50                  |                        |                |                      | 25.4     | 1.51 mm (#53)                         | LP16           | NO      | 3.8/4.4 |
|   |       |               | I <sub>3P</sub>                    |                    |                  |                |                        |                        |                |                      |          |                                       |                |         |         |
| BE, BG, CH, CZ, DE, ES, FR, GB, GR, HR, HU, IE, IS, IT, LT, LU, LV, MK, MT, NL, PL, PT, RO, SI, | Pro   | G31           | I <sub>3P</sub>                    |                    |                  |                |                        |                        |                |                      |          | 1.5                                   |                |         |         |

**Belgium** – Natural gas units require a restrictor orifice on the supply line for proper operation.

| Model                   | Fuel Type | Gross Input BTUS (kW) | Net Input BTUS (kW) | Supply Pressure (mbar) | Burner Pressure (mbar) | Burner Orifice | Pilot Orifice (code) |
|-------------------------|-----------|-----------------------|---------------------|------------------------|------------------------|----------------|----------------------|
| <b>NON-CE GAS TABLE</b> |           |                       |                     |                        |                        |                |                      |
| 35C                     | Natural   | 90,000 (26.3)         | 24                  | 7" W.C. (17.4)         | 4" W.C. (10)           | #39            | N22                  |
|                         | Propane   |                       |                     | 11" W.C. (27.4)        | 10 W.C. (25)           | .0625"         | LP16                 |
| 40C                     | Natural   | 105,000 (30.8)        | 28                  | 7" W.C. (17.4)         | 4" W.C. (10)           | #36            | N22                  |
|                         | Propane   |                       |                     | 11" W.C. (27.4)        | 10 W.C. (25)           | #51            | LP16                 |
| 40D                     | Natural   | 107,000 (31.3)        | 28                  | 7" W.C. (17.4)         | 4" W.C. (10)           | #42            | N22                  |
|                         | Propane   |                       |                     | 11" W.C. (27.4)        | 10 W.C. (25)           | 1.5 mm         | LP16                 |
| 45C                     | Natural   | 122,000 (35.8)        | 32                  | 7" W.C. (17.4)         | 4" W.C. (10)           | #38            | N22                  |
|                         | Propane   |                       |                     | 11" W.C. (27.4)        | 10 W.C. (25)           | #52            | LP16                 |
| 65C                     | Natural   | 150,000 (44)          | 40                  | 7" W.C. (17.4)         | 4" W.C. (10)           | #39            | N22                  |
|                         | Propane   |                       |                     | 11" W.C. (27.4)        | 10 W.C. (25)           | .0625"         | LP16                 |

| <b>AUSTRALIAN GAS TABLE</b> |                      |          |          |          |         |                  |                |
|-----------------------------|----------------------|----------|----------|----------|---------|------------------|----------------|
| 35C                         | Natural              | 95 Mj/h  | 84 Mj/h  | 1.74 kPa | 1.0 kPa | 2.53 mm (#39)    | 0.56 mm (N22)  |
|                             | ULPG                 |          | 86 Mj/h  | 2.74 kPa | 2.5 kPa | 1.59 mm (.0625") | 0.41 mm (LP16) |
| 40C                         | <b>NOT AVAILABLE</b> |          |          |          |         |                  |                |
| 40D                         | Natural              | 100 Mj/h | 90 Mj/h  | 1.74 kPa | 1.0 kPa | 2.20 mm (#44)    | 0.56 mm (N22)  |
|                             | ULPG                 |          | 92 Mj/h  | 2.74 kPa | 2.5 kPa | 1.40 mm (#54)    | 0.41 mm (LP16) |
| 45C                         | Natural              | 129 Mj/h | 116 Mj/h | 1.74 kPa | 0.9 kPa | 2.58 mm (#38)    | 0.56 mm (N22)  |
|                             | ULPG                 |          | 118 Mj/h | 2.74 kPa | 2.5 kPa | 1.61 mm (#52)    | 0.41 mm (LP16) |
| 65C                         | Natural              | 144 Mj/h | 130 Mj/h | 1.74 kPa | 1.0 kPa | 2.38 mm (#42)    | 0.56 mm (N22)  |
|                             | LP                   |          | 133 Mj/h | 2.74 kPa | 2.5 kPa | 1.51 mm (#53)    | 0.41 mm (LP16) |



**the Netherlands Only - Natural Gas**

*Dit toestel is afgesteld voor de toestelcategorie K (I<sub>2K</sub>) en is geschikt voor het gebruik van G en G+ distributiegassen volgens de specificaties zoals die zijn weergegeven in de NTA 8837:2012 Annex D met een Wobbe-index van 43,46 – 45,3 MJ/m<sup>3</sup> (droog, 0 °C, bovenwaarde) of 41,23 – 42,98 (droog, 15 °C, bovenwaarde). Dit toestel kan daarnaast worden omgebouwd en/of opnieuw worden afgeregeld voor de toestelcategorie E (I<sub>2E</sub>) Dit houdt derhalve in dat het toestel: “geschikt is voor G+-gas en H-gas, dan wel aantoonbaar geschikt is voor G+-gas en aantoonbaar geschikt is te maken voor H-gas” in de zin van het “Besluit van 10 mei 2016 tot wijziging van het Besluit gastoestellen....”*

**1.4. HEAT DEFLECTOR INSTALLATION**

If the appliance requires a heat deflector, you will find a removable label at the rear top edge of the unit. This label has instructions for positioning and installation of the heat deflector. Refer to the label and the instructions below to install the deflector.

1. Remove the two self-drilling screws from the top, back area of the appliance.
2. Position the heat deflector so that the angled portion of the deflector is facing toward the front of appliance. Secure the heat deflector to the back of the unit using the two previously removed fasteners.
3. When properly installed the angled section of the heat deflector will extend over the flue opening to redirect the heat. It SHOULD NOT cover the flue opening. Never allow anything to block the flue opening; this will cause the appliance to overheat and inhibit proper combustion, which could produce dangerous gases

**2. GAS CONNECTION**

Your gas appliance will give you peak performance when the gas supply line is of sufficient size to provide the correct gas pressure. The gas line must be installed to meet the local building codes or North America National Fuel Gas Code ANSI Z223.1 Latest Edition. In Canada, install the appliance in accordance with CAN/CGA-B149.1 or .2 and local codes. In Australia, install the appliance in accordance with AS/NZS 5601 Latest Edition. Gas line sizing requirements can be determined by your local gas company or, in North America, by referring to the National Fuel Gas Code, Appendix C, Table C-4 (for natural gas) and Table C-16 (for propane). The gas line needs to be large enough to supply the necessary amount of fuel to all appliances without losing pressure to any appliance.

**2.1. GAS SUPPLY TO THE APPLIANCE**

A properly sized and installed gas line will deliver a supply pressure between 7.0" W.C. (17.4mbars, 1.74kPa) and 10.0" W.C. (24.9mbars, 2.49kPa) natural gas or between 11.0" W.C. (27.4mbars, 2.74kPa) and 13.0" W.C. (32.4mbars, 3.25kPa) for propane to all appliances connected to the supply line, operating simultaneously at full demand.

- **THE PRESSURE AT THE GAS CONTROL VALVE SHALL NOT EXCEED ½ PSI (13.84 “WC, 34.5 mbar, 3.45 kPa).**

The gas supply connection to this appliance is located in the rear of the appliance approximately 10-1/2" (26.7 cm) from the floor of the appliance when legs are used.

Each appliance is equipped to operate on one certain fuel type. The type of fuel with which the appliance is intended to operate is printed on the data plate, which is attached to the inside of the door.

**WARNING**

**NEVER supply the appliance with a gas other than the one that is indicated on the data plate. Using the incorrect gas type will cause improper operation and could result in serious injury or death. If you need to convert the appliance to another type of fuel, contact the dealer you purchased it from.**

**NOTICE**

**NEVER use an adapter to make a smaller gas supply line fit the appliance connection. This may not allow proper gas flow for optimum burner operation, resulting in poor performance and improper operation.**

## 2.2. QUICK DISCONNECT CONNECTION

In North America, gas appliances equipped with casters must be installed with connectors that comply with the Standard for Connectors for Movable Gas Appliances, ANSI Z21.69.CSA 6.16 Latest Edition. This connection should include a quick disconnect device that complies with the Standard for Quick Disconnect Devices for Use with Gas Fuel Appliances ANSI Z21.41.CSA 6.9 Latest Edition. In Australia, an appliance equipped with casters and a flexible gas line must be connected to the gas supply with a quick disconnect device that complies with AS 4627 Latest Edition and a restraining cable. The restraining cable must not exceed 80% of the length of the flexible gas line. The restraining device should be attached to the appliance at the back panel.

For Australia, the appliance must be installed in accordance with AS/NZS 5601 Latest Edition, local authority and any other relevant statutory regulations. Flexible hose (if used) must comply with AS/NZS 1869 Class B or D, be of appropriate internal diameter, be kept as short as possible (not exceed 1.2 meters), must not be kinked and not be in contact with a hot surface. A chain must be fitted to restrict the appliance movement to no more than 80% of the hose length.

## 2.3. FUEL SUPPLY LINE LEAK AND PRESSURE TESTING

The fuel supply system must be tested before the appliance is used. If the fuel line is going to be tested at a pressure greater than ½ PISG (3.45 kPa, 34.5 mbar), ensure that that appliance is disconnected from the fuel line. If the fuel line is to be tested at a pressure equal to or less than ½ PSIG (3.45 kPa, 34.5 mbar), the appliance can be connected during the test, but the unit's gas control valve must be turned OFF. Test all gas line connections for leaks with a solution of soap and water when pressure applied.

## 2.4. INSTALLATION SETUP

The installation of this appliance *MUST* conform to local codes. In the absence of local codes in North America, the installation must conform with the National Fuel Gas Code, ANSI Z223.1/NFPA 54 Latest Edition or the Natural Gas and Propane Installation Code CSA B149.1 Latest Edition as applicable. In Australia, the appliance must be installed in compliance with AS/NZS 5601 Latest Edition

## 2.5. VENTILATION AND FIRE SAFETY SYSTEMS

Your new appliance must have proper ventilation to function safely and properly. Exhaust gas temperatures can reach as high as 1100 °F (593 °C). Therefore, it is very important to install a fire safety system. Your ventilation system should be designed to allow for easy cleaning. Frequent cleaning and proper maintenance of the ventilation system and the appliance will reduce the chances of fire. Ventilation and fire safety systems must comply to local and national codes for US and Canada. Refer to ANSI 83.11 for a list of reference documents that will provide guidance on ventilation and fire safety systems. For installations in U.S. and Canada, additional information can be obtained from CSA International, 8501 East Pleasant Valley Road, Cleveland, OH, 44131 or visit their website at [www.csa-international.org](http://www.csa-international.org). In Australia, the ventilation system must comply with AS/NZS 5601.0.

It is essential that the appliance be operated only when adequate ventilation is provided. Your ventilation hood should be properly maintained. A qualified installation professional should ensure that the hood is operating properly in conjunction with the appliance. Inadequate ventilation may not properly evacuate all appliance emissions. Excessive or unbalanced ventilation may cause drafts, which could interfere with proper operation of the pilot and burners. Leave at least 18 inches (47 cm) of open space between the flue of the appliance and the intake of the exhaust hood.

### WARNING

**Ensure that your ventilation system does not cause a down draft at the appliance's flue opening. A down draft will not allow the appliance to exhaust properly and will cause overheating, which may cause permanent damage. Damage caused by down drafts will not be covered by the warranty. NEVER allow anything to obstruct the flow of combustibles or ventilation exiting the appliance. NEVER place anything on top of the flue area, or block the flue in any way. Never place a grease condensing drip pan over the flue opening.**

### WARNING

**NEVER connect the ventilation blower or hood directly to the flue of this appliance. The resulting increased flow of air through the combustion system will cause improper operation, poor temperature recovery, poor ignition and could extinguish the pilot.**

**WARNING**

Replacing or adding appliances under a pre-existing fire safety system may require modifications to the system. **ALWAYS** contact a professional who is qualified in installing, designing and maintaining your fire safety system to assure that any appliances located under the fire safety system are adequately protected.

**2.6. INSPECTION**

Before you begin filling and adjusting the appliance, perform the following visual checks:

- ✓ After the appliance is in its permanent location, check the levelness. Any additional leveling that is necessary can be performed as previously described.
- ✓ Ensure that the sensing probe and high temperature limit bulb are in place and secure. Check the high limit bulb mounting screws to ensure that they are tight.
- ✓ Review the installation portion of this manual and ensure that all steps have been followed and executed properly.

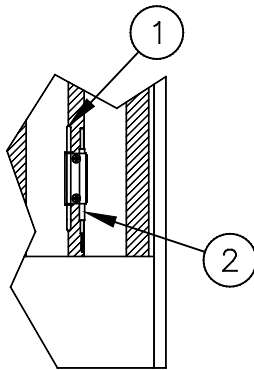

- 1) Probe
- 2) High Temperature Limit

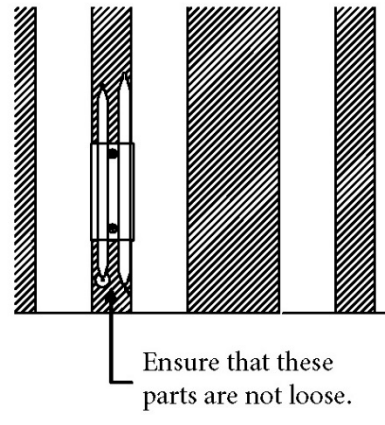

**2.7. INITIAL ADJUSTMENTS**

After your appliance has been properly installed as described in the INSTALLATION section of this manual, it will need to be adjusted to ensure that it will perform as designed. A qualified person must perform these adjustments.

**To perform these adjustments the following tools will be needed:**

- Manometer
- Digital Thermometer (Temperature Probe)
- DC Voltmeter (capable of reading millivolts)

**2.7.1. FILLING THE APPLIANCE FOR ADJUSTMENT & INITIAL CLEANING**

Refer to the following procedure to fill the cook tank prior to making adjustments.

1. Ensure that the drain valve is **closed**.
2. Fill the tank with WATER. Water is used for the installation adjustments because the temperature will never exceed 212°F (100°C), thereby allowing plenty of adjustment time. Never let the water level go below the MIN LEVEL mark stamped on the tank.

**WARNING**

**Oil/shortening must completely cover the heat tubes at all times while appliance is ON.**

**CAUTION**

**This appliance is not designed for cooking with water. Fill with oil/shortening only for cooking.**

**WARNING**

During operation, there is an open flame inside this appliance. The unit may get hot enough to set nearby materials on fire. Keep the area around the appliance free from combustibles.

**WARNING**

If pilot extinguishes, wait 5 minutes before attempting to relight the pilot to allow any built-up gas to dissipate.

**2.7.2. LIGHTING INSTRUCTIONS**

Refer to the following instructions to light the appliance.

1. Verify that all clearances, gas connections, ventilation requirements and gas pressures have been properly implemented, tested, adjusted and checked for compliance in accordance with the instructions and requirements in the INSTALLATION section of this document prior to proceeding.
2. Open the gas supply valves to the appliance.
3. Turn the thermostat control knob counterclockwise to the OFF position.
4. Turn the gas control valve knob to the PILOT position and push in on the knob. Hold the knob in for approximately one minute to purge the air out of the line.
5. While keeping the knob on the gas control valve depressed, hold a flame to the pilot until the pilot ignites.
6. Keep the knob on the gas control valve pressed for approximately 30 seconds or until the pilot remains lit without the knob being pressed.
7. If the pilot goes out, wait 5 minutes and repeat step 4. If after three tries the pilot will not remain lit, refer to the TROUBLESHOOTING section of this manual.
8. Once a pilot flame has been established, turn the gas control valve knob counterclockwise to the ON position.
9. Set the thermostat control knob to the desired temperature setting, the burners will ignite and be controlled by the thermostat.

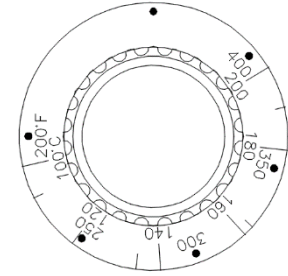

Thermostat Control Knob



**PILOT**

**ON**

Gas Control Valve Knobs

**WARNING**

Do not store flammable materials in or near this appliance. Do not spray aerosols in the vicinity of this appliance while it is in operation. Contact a qualified service person or the factory, using the information on the back of this manual, if the appliance produces unusual odor, yellow tipping flames or is not performing as per the original installation.

### 2.7.3. PILOT FLAME ADJUSTMENT

Perform this procedure with the pilot lit.

**Note: This procedure requires a DC millivolt meter set to a scale of 0-1000 mV. Using test leads with sharp probes will help in taking the required readings. Using test leads with sharp probes will help in taking the required readings**

- 1A. GS systems, Locate the Hi-limit wires (white) coming from the thermostat/hi-limit bracket going to the gas control valve. The wire size decreases near the gas control valve connections.
- 1B. Millivolt systems, Locate the thermopile wires coming from the pilot to the gas control valve.
- 2A. GS systems, Using the positive (+) test probe, connect the probe to the high limit wire terminal or pierce the high limit wire insulation, with the tip of the test lead probe, at the gas control valve safety magnet connection. Then connect the negative (-) test probe to the pilot tubing
- 2B. Millivolt systems, Connect the positive (+) test probe to the PP or TP terminal with the red wire. Then connect the negative (-) test probe to the PP or TP terminal with the white wire.
3. Adjust the current reading to the required level by adjusting the pilot flame. Remove the pilot adjustment cap screw to expose the pilot adjustment screw. Turning the pilot adjustment screw clockwise will decrease the size of the pilot flame and flame sense current. Turning the pilot adjustment screw counterclockwise will increase the pilot flame size and the flame sense current.
- 4A. GS systems, Turn the screw in or out as needed to achieve a reading of  $25\text{ mV} \pm 5\text{ mV}$ .
- 4B. Millivolt systems, Turn the screw in or out as needed to achieve a reading of  $550\text{ mV} \pm 50\text{ mV}$ .

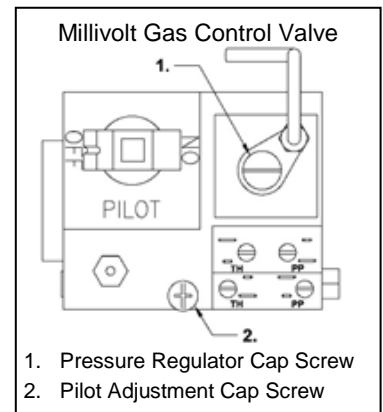
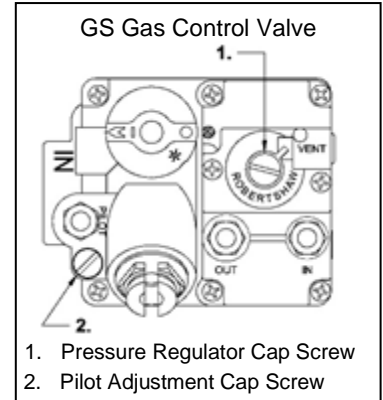

**Note: Allow 3 to 5 minutes between flame adjustments to allow the reading to stabilize.**

Once the pilot flame has been adjusted properly, remove the millivolt meter and replace the pilot adjustment cap screw.

### 2.7.4. BURNER SYSTEM ADJUSTMENT

For the burners to operate the gas control valve must be open and the thermostat must be turned ON. The burners receive gas from the main gas supply through the thermostatically controlled gas control valve. When the oil temperature drops below the preset temperature the gas control valve opens.

The burners must be adjusted to deliver optimum flame. Refer to the following procedure to adjust the burners.

1. Ensure that the gas control valve is turned OFF, remove the burner pressure tap plug and connect an accurate pressure gauge (range of 0-16 "W.C. (39.85mbar, 3.98kPa) in 0.1" (.25mbar, .02kPa) increments) or manometer.
2. Turn on this and all appliances connected to the gas supply line and light their burners. The pressure reading of the installed pressure gauge should not drop from the required installation pressure. Any loss of pressure indicates inadequate supply line installation, which will cause poor performance of all appliances during peak usage.

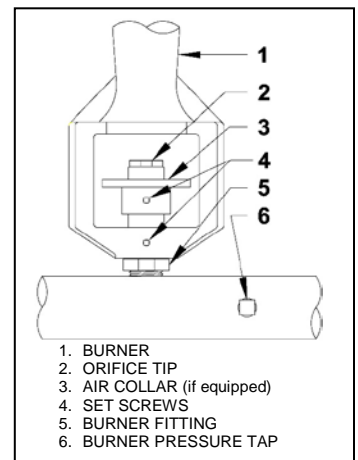

The installed pressure gauge should be the same,  $\pm 0.1$ " W.C. (.25mbar, .02kPa), as that marked on the data plate on the inside door of the appliance. If the pressure is correct, go to step 6, if it is not, adjust the pressure as outlined in step 4.

**IF the pressure cannot be set to within these limits of the pressure stated on the data plate, DO NOT operate the appliance. Contact an Authorized Service Company.**

## PITCO FRYER INSTALLATION & OPERATIONAL MANUAL

3. To adjust the pressure, remove the pressure regulator cap screw and, with a flat head screwdriver, adjust the regulator screw until the proper burner pressure is reached. Turning the screw clockwise will increase the burner pressure. Turning the screw counterclockwise will decrease the burner pressure. When the pressure is correct, replace the pressure regulator cap screw.
4. Turn OFF ALL appliances, turn OFF the gas control valve to your Pitco appliance and remove the pressure gauge. Apply pipe joint compound to the burner pressure tap plug and reinstall it.
5. Check for leaks at the pressure tap fitting.

### **CAUTION**

**If the appliance can't be adjusted to operate properly contact a qualified service person or contact the factory using the contact information on the back of this manual.**

### **CAUTION**

**Be careful not to disturb the probe and high temperature limit bulb and capillary during operation and cleaning of this appliance.**

## **2.8. INITIAL CLEANING**

When your appliance is shipped, many of its parts are covered with a thin coat of oil for protection. Before the appliance is ready for cooking, remove all transit materials and the appliance must be cleaned. This will remove the oil coating and any foreign matter that may have accumulated during storage and shipment. Refer to the following procedure to clean the appliance.

### **WARNING**

**Wear protective gloves and clothing when cleaning and draining the appliance and when disposing of water. The water is extremely hot and can cause severe injuries.**

### **CAUTION**

**DO NOT leave the appliance unattended during cleaning. Never let the liquid level go below the heat tubes.**

1. Read the OPERATION section of this manual prior to filling or operating the appliance.
2. The following steps should be followed using a food grade cleaner.

### **WARNING**

**Use a commercial grade cleaner formulated to effectively clean and sanitize food contact surfaces. Read the directions and precautionary statements before use. Particular attention must be paid to the concentration of cleaner and the length of time the cleaner remains on the food contact surfaces.**

3. Following the cleaning directions in this manual to clean the tank interior and all other food contact surfaces. (6.3.1 Boil Out Procedure, page 20)
4. When cleaning is complete, rinse the inside of the tank thoroughly with cool water. Continue to rinse the tank until the cleaner has been completely and thoroughly rinsed from the tank.
5. Using a clean dry cloth, wipe out all of the water in the fry tank.

### 3. OPERATION

**WARNING**

Before operating the fryer, check that tipping restraints or other features to prevent tipping are installed and mechanically sound. Splashing of hot liquid may occur if adequate means of securing the fryer in place are not used.

**WARNING**

Opening the drain valve will lead to the outflow of the hot contents of the deep fat fryer.

**NOTICE**

These appliances are intended to be used for commercial applications, for example in the kitchens of restaurants, canteens, hospitals and in commercial enterprises such as bakeries, butcheries, etc., but not for continuous mass production of food.

#### 3.1. FILLING THE COOK TANK

Both liquid and solid oil/shortening can be used in this appliance, but liquid is preferred. If solid oil/shortening is used it is recommended that you melt the oil/shortening before adding it to the appliance. You can melt solid oil/shortening in the appliance, but you must be very careful not to scorch the oil/shortening.

**CAUTION**

This appliance is **NOT** designed for cooking with water. Cook with oil or shortening only.

#### 3.2. FILLING THE COOK TANK WITH LIQUID OIL/SHORTENING

To fill the tank with liquid shortening, refer to the following procedure.

##### OIL CAPACITIES

| FRYER MODEL | TANK OIL CAPACITY* |             |             |
|-------------|--------------------|-------------|-------------|
|             | Lbs.               | kg          | liter       |
| 35C         | 35 - 40            | 15.9 - 18.1 | 17.5 - 20.0 |
| 40C / 40D   | 40 - 45            | 18.1 - 20.4 | 20.0 - 22.5 |
| 45C         | 42 - 50            | 19.1 - 22.7 | 21.0 - 25.0 |
| 65C         | 65 - 80            | 29.5 - 36.3 | 32.4 - 39.9 |

\* Per Tank, weight/volume based on Canola Oil

It is recommended that high quality liquid frying oils be used for longest oil life.

1. Verify that the tank interior is clean and free of any construction debris and moisture.
2. Rinse the tank and drain line with a small amount of clean cooking oil.
3. Ensure that the drain valve is **closed**.
4. Fill the tank to about the MIN oil level mark. The oil will expand when heated up, raising the level to OIL LEVEL line.
5. After the cooking oil is at operating temperature, add oil to the frypots as needed to obtain the desired operating level.

### 3.3. FILLING THE TANK WITH SOLID OIL/SHORTENING

Illustration of liquid oil/shortening fill.

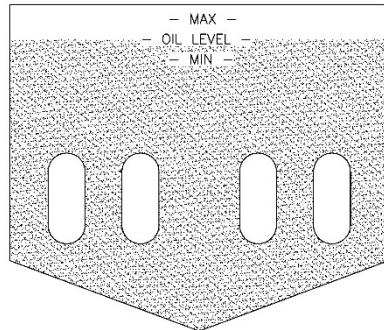

To fill the tank with solid oil/shortening refer to the following procedure

1. Remove the screen covering the heat tubes (tube screen).
2. Cut the solid oil/shortening into cubes no larger than one inch (2.54 cm). ALWAYS pack the oil/shortening below, between, and on top of the heat tubes.  
**DO NOT leave any large air gaps. Use care when packing the solid oil/shortening into the tank.**  
**DO NOT bend or break the temperature or high limit sensor probes. If these are damaged the appliance will not function properly.**
3. Once the appliance tank is firmly packed with solid oil/shortening, the oil/shortening must be melted. Melt the oil/shortening by cycling the burners ON for 4 seconds and OFF for 30 seconds repeatedly, using the thermostat knob.

**AVOID these conditions.**

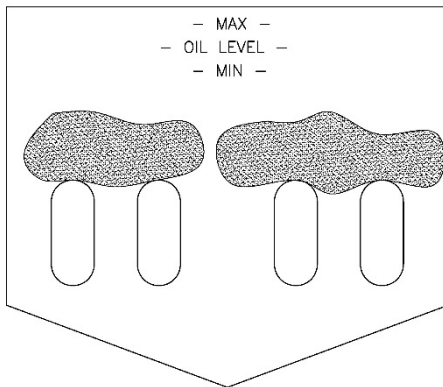

**Very Hazardous**

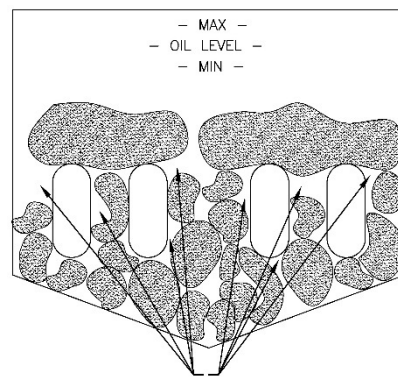

**Excessive and large spaces**

|  |
|--|
| <p><b>WARNING</b></p> <p>Replace oil/shortening that is smoking, or foams when cooking. Old, heavily used oil/shortenings have reduced flash point, and are prone to surge boiling. Cooking with old, heavily used oil/shortening may create dangerous conditions.</p> |
| <p><b>WARNING</b></p> <p>Oil must completely cover the heat tubes at all times while appliance is on.</p>  |



**WARNING**

Do not overload the fry baskets, or allow the oil level to exceed the MAX line while cooking. Wet product, or too much oil in the frypot can lead to surge boiling, and over topping the frypot. Overtopping may create hazards such as burns or slippery floors.

**CAUTION**

This appliance is NOT designed for cooking with water. Severe equipment damage will occur if a fryer is used as a water bath for rethermalizing foods. Damage of this type is not covered under the warranty.

## 4. APPLIANCE START UP

Refer to the following procedure to start the appliance prior to operation.

1. Fill the cook tank with oil/shortening (See Section 2.1 FILLING THE COOK TANK). Never operate the appliance unless the cook tank is properly filled.
2. Light the pilot as previously described in this manual.
3. Turn the temperature control knob (thermostat) to the desired temperature setting. This knob is located behind the door.
4. The appliance is now on and heating the oil/shortening in the cook tank.

**WARNING**

**NEVER operate the appliance with an empty fry tank. It will void the warranty.**

**WARNING**

**Oil/shortening level should NOT be allowed to fall below the indicated level line at any time. Dry firing of the fry tank will shorten tank service life and will void your warranty.**

**WARNING**

**Oil level should NOT be allowed to fall below the indicated level line at any time. Dry firing of the tank may cause a fire, and can shorten tank service life. Evidence of dry firing will void your warranty.**

**OIL TEMPERATURE**

Keep the oil temperature in the fryer to a maximum of 190°C (374°F). Higher temperatures will cause rapid breakdown of the oil and give you no faster cooking. At 205°C (401°F) to 210°C (410°F) the life of the oil is only one third of its life at 190°C (374°F). In addition, increased decomposition causes the oil to smoke badly even if the temperature is lowered to 190°C (374°F) again. High temperatures give you no advantage, cost you money and increase the fire danger.

**TEMPERATURA DELL'OLIO**

Mantenere la temperatura dell'olio nella friggitrice fino a un massimo di 190°C. Temperature maggiori causano un rapido degrado dell'olio, senza tuttavia eseguire una cottura più rapida. Da 205°C a 210°C la durata dell'olio è inferiore di un terzo rispetto a quella a 190°C. Inoltre, l'accresciuta decomposizione comporta una forte emissione di fumo, anche se la temperatura viene riportata di nuovo a 190°C. Le alte temperature non prevedono vantaggi, sono antieconomiche e aumentano il rischio d'incendio.

**ΘΕΡΜΟΚΡΑΣΙΑ ΛΑΔΙΟΥ**

Διατηρείτε τη θερμοκρασία λαδιού στη φριτέζα μέχρι 190 βαθμούς Κελσίου. Υψηλότερες θερμοκρασίες θα αλλάξουν τη σύνθεση του λαδιού πολύ σύντομα και δεν ψήνεται γρηγορότερα. Η δυναμικότητα του λαδιού στους 205-210 βαθμούς Κελσίου είναι μόνο το ένα τρίτο της δυναμικότητάς του στους 190 βαθμούς Κελσίου. Επιπλέον η αυξημένη αποσύνθεση του λαδιού, σε θερμοκρασίες πάνω από 190 βαθμούς Κελσίου, κάνει το λάδι να καπνίζει άσχημα κι αν ακόμη κατεβάσετε τη θερμοκρασία κατόπιν πάλι στους 190 βαθμούς Κελσίου. Οι υψηλές θερμοκρασίες δε σας παρέχουν κανένα πλεονέκτημα, σας κοστίζει περισσότερα χρήματα και αυξάνουν τον κίνδυνο πυρκαγιάς.

**4.1. COOKING**

To ensure the quality of the food you cook in this appliance, follow the preparation instructions from the food manufacturer. When the appliance is not in use, the oil should be cooled and covered to prevent contamination.

| Maximum Allowable Load per Tank Size (W x L) |                                |                                |                                |                                |
|--|--------------------------------|--------------------------------|--------------------------------|--------------------------------|
| 7 x 14 in<br>(17.8 x 35.6 cm)                | 14 x 14 in<br>(35.6 x 35.6 cm) | 18 x 18 in<br>(45.7 x 45.7 cm) | 14 x 18 in<br>(35.6 x 45.7 cm) | 18 x 14 in<br>(45.7 x 35.6 cm) |
| 1.5 lbs. (0.68kg)                            | 3 lbs. (1.36 kg)               | 5 lbs. (2.27 kg)               | 3 lbs. (1.36 kg)               | 5 lbs. (2.27 kg)               |

**4.2. COOKING TIPS**

- ✓ Always follow the food manufacturer's directions.
- ✓ The lower the oil temperature, the longer the cooking time and the greater the fat absorption.
- ✓ NEVER overfill appliance baskets. Overfilling can result in soggy, greasy product.
- ✓ When removing baskets from the cook tank, shake gently to remove excess oil.
- ✓ Never leave a basket over the appliance. The heat from the cook tank will continue to cook the product.
- ✓ Oil/shortening quality can affect product quality. Keep salt and water away from the oil/shortening to maintain its life. Oil/shortening filtration removes crumbs from the oil which will also extend its life.

**Typical French Fry Cook Times (m/s)**

| Fry Thickness | Temperature      |                  |                  |
|---------------|------------------|------------------|------------------|
|               | 350°F<br>(177°C) | 360°F<br>(182°C) | 370°F<br>(188°C) |
| Thin          | 2:45             | 2:30             | 2:15             |
| Medium        | 3:45             | 3:30             | 3:15             |
| Thick         | 4:15             | 4:00             | 3:45             |

*This table is for reference only. Please refer to the product manufacturer's specifications to determine exact cook temperatures and times.*

**WARNING**

**Dry fired heat tubes are extremely hot, will shorten the tank service life and will void your warranty.**

**5. APPLIANCE SHUTDOWN**

There are two shutdown modes of appliance operation: STANDBY and COMPLETE. The standby mode removes the ability of the appliances burners to operate. COMPLETE shutdown turns off the gas supply to the appliance. A STANDBY shutdown can be used during slow business periods. ALWAYS perform a COMPLETE shut down when the appliance will not be in use and unsupervised for an extended period of time. Refer to the following procedures to enter the appropriate shutdown mode.

**5.1. STANDBY MODE**

1. Turn the thermostat to the OFF position. Turn the Pilot knob clockwise to the PILOT position. The cooker is now in Standby and can remain this way for only brief periods of time. NEVER leave the appliance in standby mode for prolonged periods or overnight.

**5.2. COMPLETE SHUTDOWN**

1. Turn the thermostat knob to the OFF position.
2. Depress and turn the Pilot knob counter clock-wise to the OFF position.
3. The appliance is now completely shut down and can be cleaned and filtered if desired.

**6. PREVENTATIVE MAINTENANCE**

**6.1. DAILY PREVENTATIVE MAINTENANCE**

Performing the preventative maintenance steps below daily will keep your equipment safe and at peak performance. During the cooking process, oil/shortening may spill and splatter and requires immediate attention. Furthermore, during the cooking process, particles, crumbs and crackling collect inside the fry tank reducing product quality and decreasing oil/shortening life. If you are producing high quantities of fried food and/or frying heavily battered food, it will be necessary to perform these steps more than once a day.

**WARNING**

**Serious injury could result from direct contact with hot surfaces and/or oil. Always wear apron, heat resistant gloves for skin protection and goggles for eye protection.**

**6.1.1. DAILY CLEANING**

At least daily, filtering the oil is required. Make sure a clean filter is used every day. Using the cleaning brush, crumb scoop and clean out rod, remove all the loose debris

**6.1.2. APPLIANCE INSPECTION**

- ✓ Check that the high temperature limit and temperature probe are in the correct position and secured in place. (Refer to illustration on page 11 of this manual).
- ✓ Check around the appliance for loose parts or accessories that need to be secured or other foreign items (ex: Aerosol cans) that should be removed from the area.
- ✓ Check for oil/shortening leaks around the inside and outside of the cabinet and around the appliance.

|  |
|--|
| <p><b>WARNING</b><br/>                 Serious injury could result from direct contact with hot surfaces and/or oil. Always wear apron, heat resistant gloves for skin protection and goggles for eye protection</p> |
| <p><b>WARNING</b><br/>                 Read the <b>OPERATION</b> section of this manual prior to filling or operating the appliance.</p>   |
| <p><b>WARNING</b><br/>                 DO NOT leave the appliance unattended during cleaning.</p>  |

**6.1.3. CLEANING THE COOK TANK**

Recommended at least once a week.

1. Follow the procedure from 4.2. (COMPLETE SHUTDOWN) turn OFF and drain the oil/shortening. Allow the unit to cool, then perform the following procedure for cleaning.
2. Remove baskets, tank rack and basket hanger for cleaning in pot sink, power soak sink or dishwasher.
3. Using the cleaning brush, crumb scoop and clean out rod, remove all the loose debris and scrub all tank surfaces.
4. For tougher carbonized oil/shortening and carbon buildup scrub tank using a Scotchbrite or other abrasive pad. **DO NOT** use steel wool.
5. Wipe residue with a clean water dampened cloth. Carefully dry and **REMOVE ALL MOISTURE** from the tank before returning oil/shortening into the tank.
6. Clean and dry baskets, tank rack and basket hanger before reinstalling.
7. Refill tank with oil/shortening.

**6.1.4. CLEANING THE CABINET**

1. Wipe any spilled oil/shortening, dust and lint from the cabinet exterior with a clean damp cloth and a mild food grade detergent. Be careful not to get any water or detergent in the oil/shortening. Use a nonabrasive pad for tougher stains if needed.
2. Remove detergent from all surfaces.
3. Cleaning the interior cabinet requires a clean cloth to remove any oil/shortening, dust, lint or filter powder (i.e.: Magnesol) from the interior of the cabinet.

## **6.2. WEEKLY PREVENTATIVE MAINTENANCE**

Performing the preventative maintenance steps above on a daily basis will keep your equipment clean and safe. On a weekly basis, these additional steps should be performed. Wear personal protective gear when performing preventative maintenance!

1. Turn the appliance OFF. Allow the oil/shortening to cool to room temperature before pulling the appliance away from the hood. Hint: This maintenance may be ideal to perform on the day the oil/shortening is being changed so no oil/shortening is present in the tank.
2. Disconnect the gas hose and retention lanyard.
3. Wearing your protective gear, pull the appliance away from the hood.
4. Check that vent hood drip cup is empty and not dripping oil/shortening into the flue.
5. Check that the hood baffles are clean and not dripping oil/shortening into the flue.
6. Clean the appliance sides, back and the flue area, it may be necessary to use a non-abrasive pad to scour and a putty knife to scrape the oil/shortening buildup. With a clean damp cloth and food grade detergent wipe the area clean.
7. Wipe up any excessive oil/shortening on the gas hose with a dry cloth.
8. Check flue pipe for any foreign debris/object and remove if found.
9. Reattach gas hose and retention lanyard then push appliance back under the hood.

## **6.3. MONTHLY PREVENTATIVE MAINTENANCE**

Food debris and oil/shortening can build up inside the tank. Performing the monthly preventative maintenance steps below will keep your equipment safe and at peak performance. If you are producing high quantities of fried food and/or frying heavily battered food, it may be necessary to clean these components more than once a month.

### **6.3.1. BOIL OUT PROCEDURE**

Wear protective gloves and clothing when cleaning and draining the appliance. Oil/shortening, water or steam may spatter and will cause injury to personnel.

1. Read the "OPERATION" section of this manual prior to filling or operating the appliance.
2. Turn the appliance OFF. Drain all the oil/shortening from the tank into a container and allow it to cool. The container must be large enough to hold the entire contents of the tank and must also be able to withstand 400°F (205°C) temperatures.
3. To drain the tank, open the drain valve.
4. Remove baskets, tank rack and basket hanger for cleaning in pot sink, power soak sink or dishwasher.
5. Remove and discard any large debris inside the tank.
6. Close the drain valve.
7. Fill the tank with water and set the thermostat for 200°F (93°C.)
8. Once the water reaches a simmer, follow the directions of the boil out product that you are using.
9. Scrub the inside of the tank using a cleaning brush safe for hot water. Care must be taken to remove all the foreign material on the tank, heat tubes, sidewalls and other components in the tank. Be careful not to loosen or damage the high limit or temperature probe during when scrubbing.
10. Drain the water from the tank into a container that is large enough to hold the contents of the tank and is suitable for use with 212°F(100°C) water.
11. Once the tank has cooled, rinse it thoroughly with clean, potable water.
12. Remove all remaining water and residue with a clean dry cloth.
13. Clean and dry baskets, tube rack and basket hanger before reinstalling
14. Close the drain valve and fill the cooker tank with oil/shortening.
15. You can now fill the tank with oil/shortening. See Section 2.1. FILLING THE COOK TANK.

**6.4. ANNUAL/PERIODIC PREVENTATIVE MAINTENANCE AND INSPECTION**

This section should ONLY be performed by a qualified service technician as part of a regular kitchen maintenance program. This inspection should take place a minimum of once a year by an Authorized Service Technician recommended by Pitco. It may be necessary perform this inspection more than once a year.

**6.4.1. SAFETY EVALUATION**

- ✓ Check legs, casters, wheels, plate welds and ensure all nuts and bolts are secured.
- ✓ Check conditions of flexible gas line and verify appliance retention / lanyard system is in place.

**6.4.2. MECHANICAL INSPECTION**

- ✓ Check frypot for shortening leaks and excessive oil build up
- ✓ Check for oil migration (Clean as required)
- ✓ Check hood drain cup, ensure it is empty and not dripping into the flue.
- ✓ Check hood baffle for clean surface, oil/water condensate can drip on and into the flue.
- ✓ Check flue for foreign debris and hood down draft currents.
- ✓ Check drain/filtration system (if equipped) for leaks
- ✓ Check for missing appliance parts, i.e.: cover strips
- ✓ Check for missing fasteners

**6.4.3. TEMPERATURE CONTROL SYSTEM**

- ✓ Check temperature probes and limits for carbon build up and plating. Clean as required
- ✓ Check proper mounting of probes and sensors and all fasteners are secure.
- ✓ Check thermistor probe resistances for stability.
- ✓ Check Controller/thermostat features to ensure they are functioning.
- ✓ Check Temperature Calibration

**6.4.4. GAS COMBUSTION SYSTEM**

- ✓ Check for gas leaks.
- ✓ Check and clean vent tube on gas control valve pressure regulator.
- ✓ Check burners, clean debris and grease from pilot and pilot orifice tips.
- ✓ Check and adjust burner gas pressure to nameplate reading.
- ✓ Check incoming gas pressure to the appliance under static and dynamic conditions.
- ✓ Check ignition system and adjust pilot flame as required.
  - Check flame sensor reading.
  - Check gap spacing and clean igniter.
- ✓ Recheck for gas leaks after inspection.

### 6.5. VENTILATION HOOD

Proper ventilation hood operation is very important for the correct operation of this appliance and the safety of personnel. The ventilation hood should be inspected at the time of installation of this appliance to ensure that it will operate properly in conjunction with the appliance. A regular schedule of examination in accordance with ANSI/NFPA 96 latest edition and/or local codes must be followed.

### 6.6. THERMOSTAT CALIBRATION CHECK

This **MUST** be performed with oil/shortening in the tank.

1. Use a high-grade pyrometer or digital thermometer suitable for temperature up to 380°F (193°C). Place the thermometer in the oil above the tip of the appliance's temperature probe within 1" (2.54 cm) (25.4 mm). Be sure not to touch the heat tube since this will measure incorrect temperatures. Allow several minutes for the thermometer to equilibrate with the oil temperature.
2. Light the pilot as described in this manual, set the thermostat to 325°F (163 °C) and allow the shortening/oil to come up to temperature. Watch the thermometer closely as the temperature rises.
3. If the shortening/oil temperature reaches 350°F (177 °C) and the burners do not turn off, turn the thermostat down. Keep lowering the thermostat setting until the burners go out.

#### **CAUTION**

**If the burners do not shut off at the LOWEST thermostat setting, the thermostat may be defective. Turn OFF the gas control valve. Contact your local service company.**

4. Let the appliance cycle 4 to 6 times before checking the temperature. Compare the thermometer temperature against the thermostat setting. If the values are more than 5°F (3 °C) apart, contact an Authorized Service Company for further assistance.

## 7. TROUBLESHOOTING

### 7.1. HIGH TEMPERATURE LIMIT SWITCH

This appliance is equipped with a high temperature limit switch. The high temperature limit switch will stop the appliance from functioning if the oil temperature in the cook tank reaches an unsafe temperature. In the event that the high temperature limit has tripped, please refer to the following procedure to reset the switch.

- a. Turn the appliance OFF.
- b. Allow the appliance ample time to cool to room temperature.
- c. Add oil/shortening to the cook tank as needed.
- d. Press the high temperature reset button.
- e. The high limit switch is now reset and the appliance is ready for startup.

#### WARNING

**DO NOT** add oil/shortening to the tank until it has been given ample time to cool down. Failure to do so may result in damage to the appliance and/or injury to the operator.

### 7.2. MILLIVOLT WIRING DIAGRAMS

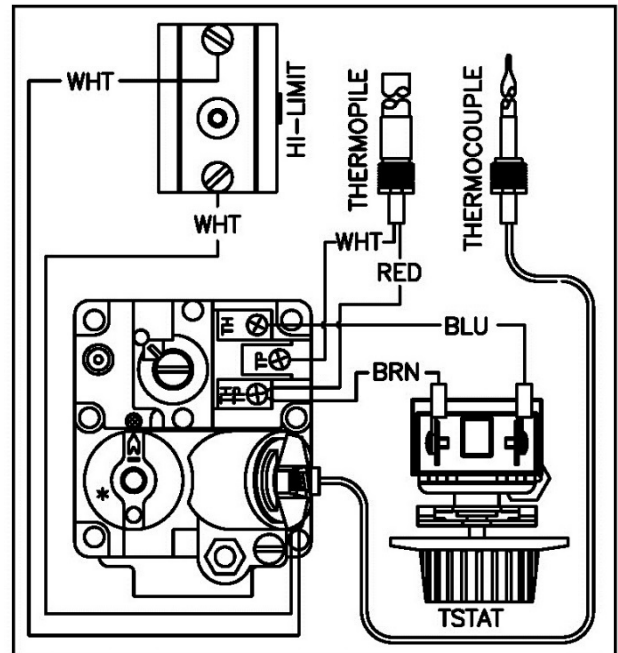
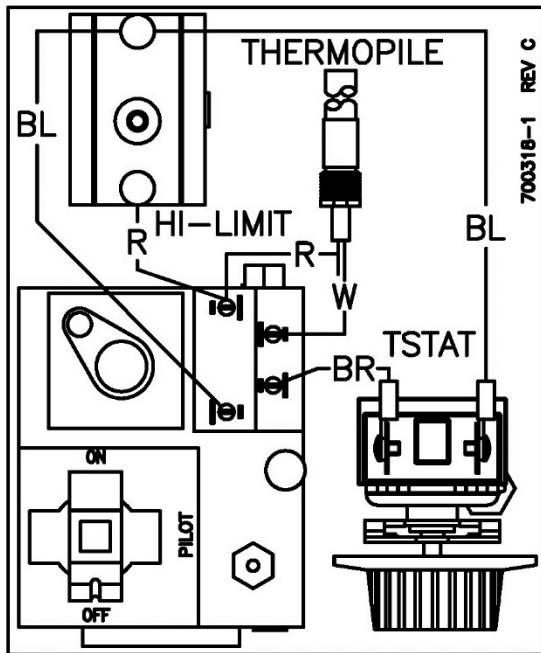

7.3. TROUBLESHOOTING CHARTS

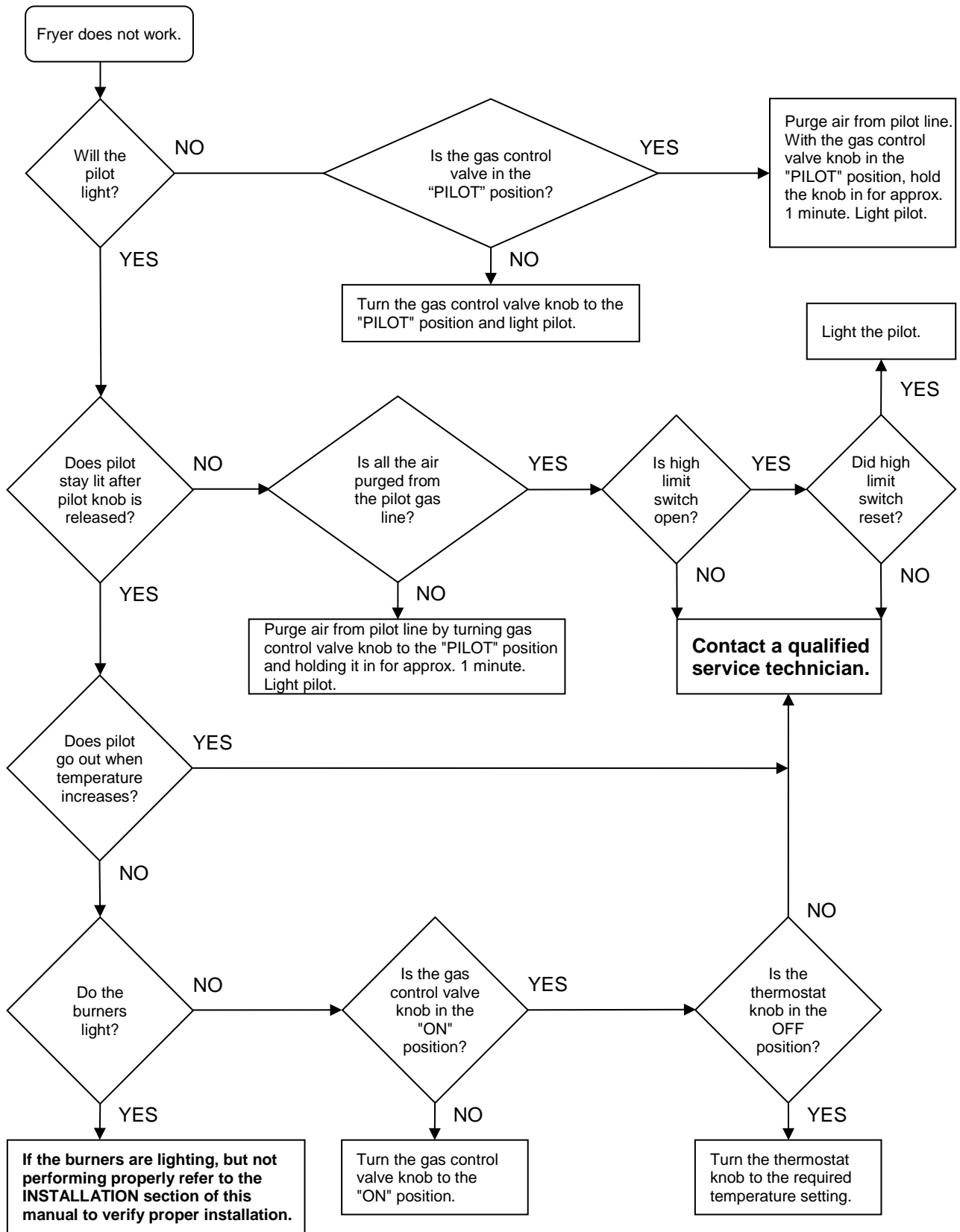



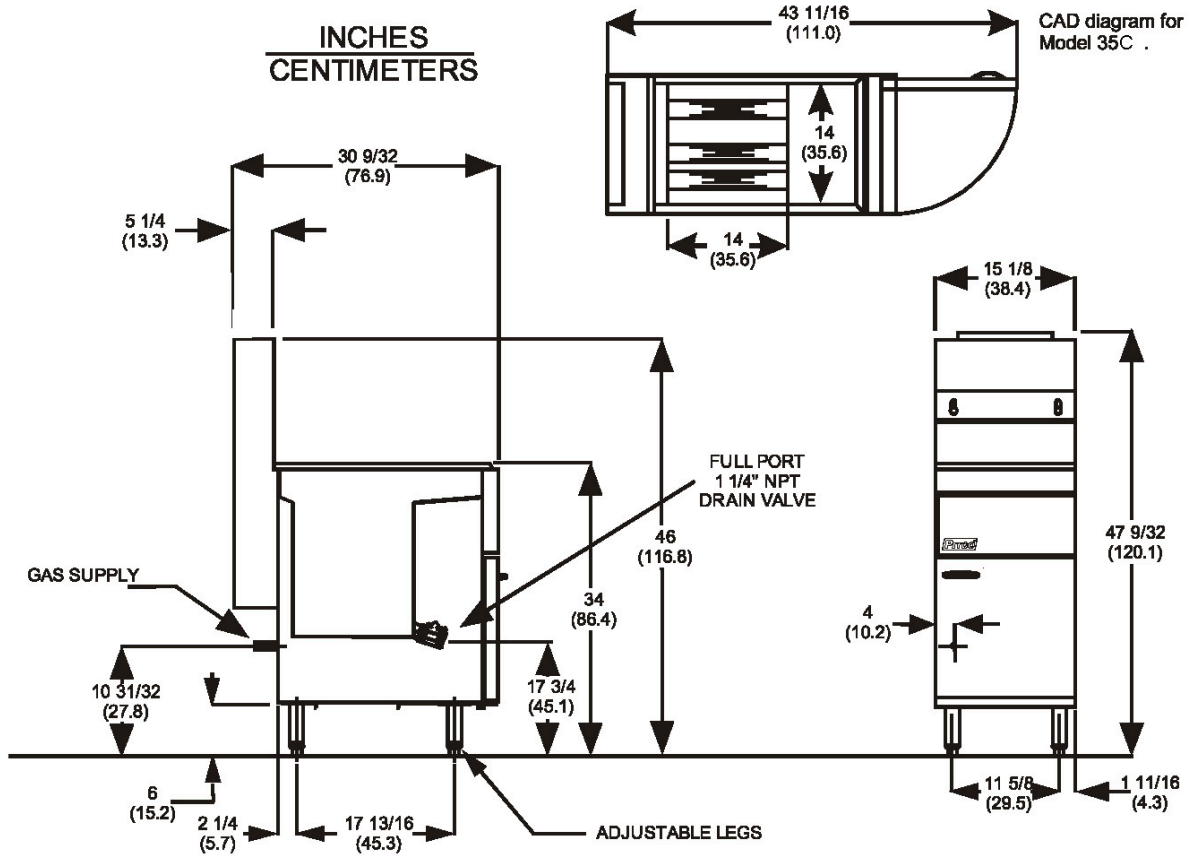

| Model                            | 35C                                       | 40C / 40D                                 | 45C                                       | 65C                                       |
|----------------------------------|---|---|---|---|
| Cooking Area Length              | 14" (35.6 cm)                             | 14" (35.6 cm)                             | 14" (35.6 cm)                             | 18" (45.7 cm)                             |
| Cooking Area Width               | 14" (35.6 cm)                             | 14" (35.6 cm)                             | 14" (35.6 cm)                             | 18" (45.7 cm)                             |
| Cooking Area Depth               | 2.0' - 3.5"<br>(5.1 - 8.9 cm)             | 4" - 6"<br>(10.2 - 15.2 cm)               | 3" - 5"<br>(7.6 - 12.7 cm)                | 3" - 5"<br>(7.6 - 12.7 cm)                |
| Overall Height                   | 47.3" (120.1 cm)                          | 47.3" (120.1 cm)                          | 47.3" (120.1 cm)                          | 47.4" (120.4 cm)                          |
| Overall Width                    | 15.1" (38.4 cm)                           | 15.1" (38.4 cm)                           | 15.1" (38.4 cm)                           | 20.2" (51.2 cm)                           |
| Overall Depth                    | 30.3" (76.9 cm)                           | 30.3" (76.9 cm)                           | 30.3" (76.9 cm)                           | 34.5" (87.5 cm)                           |
| Shipping Weight                  | 161 lbs. (73 kg)                          | 181 lbs. (82 kg)                          | 181 lbs. (82 kg)                          | 226 lbs. (103 kg)                         |
| Shipping Crate Size<br>H x W x L | 36 x 19 x 46 in<br>116.8 x 48.3 x 91.4 cm | 36 x 19 x 46 in<br>116.8 x 48.3 x 91.4 cm | 36 x 19 x 46 in<br>116.8 x 48.3 x 91.4 cm | 45 x 23 x 38 in<br>114.3 x 58.4 x 96.5 cm |

**NOTES:**

NOTES:



**Original instructions.**

Annual service to this appliance by an authorized person is recommended. Do not modify this appliance: servicing must only be carried out by an authorized person. For service and parts, minor adjustments, fault finding, or if this appliance cannot be adjusted to operate correctly, contact:

In the event of problems with or questions about your order, please contact the Pitco factory at +1 (603) 225-6684 World Wide  
Website Address: [www.pitco.com](http://www.pitco.com)

In the event of problems with or questions about your equipment, please contact the Pitco Authorized Service and Parts representative (ASAP) covering your area, or contact Pitco at the numbers listed to the left.

MAILING ADDRESS – P.O. BOX 501, CONCORD, NH 03302-0501  
SHIPPING ADDRESS – 39 SHEEP DAVIS RD., PEMBROKE, NH 03275