



IMPORTANT FOR FUTURE REFERENCE
Please complete this information and retain this manual for the life of the equipment:

Model #: _____

Serial #: _____

Date Purchased: _____

ENGLISH

Installation & Operation Manual

MKE SERIES GRIDDLES

All Options

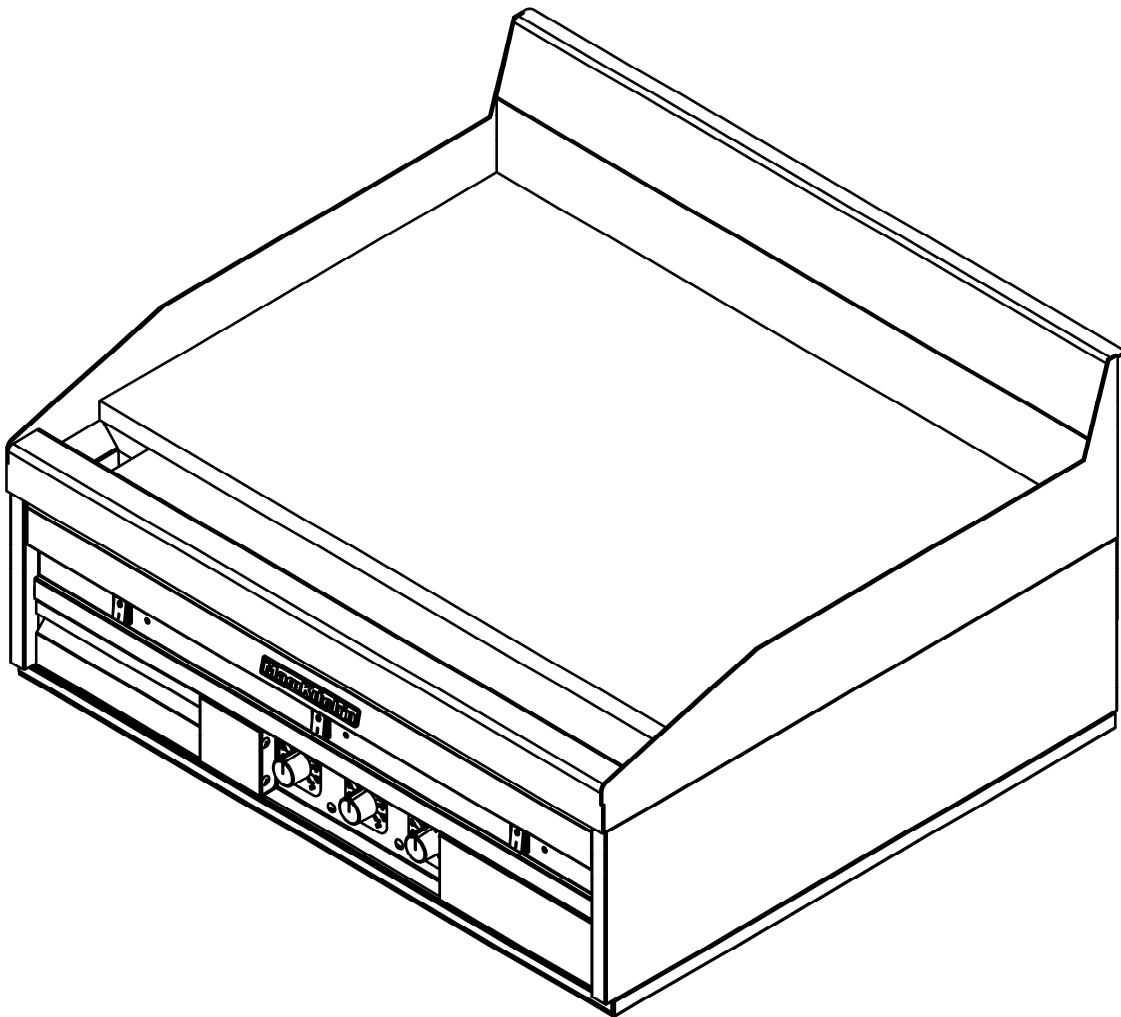

TO THE PURCHASER, OWNER AND STORE MANAGER

Please review these warnings prior to posting them in a prominent location for reference.

WARNING

DO NOT store or use gasoline or other flammable vapors and liquids in the vicinity of this or any other appliance.

WARNING

Improper installation, alteration, service or maintenance can cause property damage, injury or death. Read the installation, operating and maintenance instructions thoroughly before installing or servicing this appliance.

WARNING

Installation, maintenance and repairs should be performed by a MagiKitch'n Authorized Service and Parts (ASAP) company technician or other qualified personnel. Installation, maintenance or repairs by an unauthorized and unqualified personnel will void the warranty.

WARNING

Installation and all connections must be made according to national and local regulations and codes in force.

WARNING

A country approved all pole circuit breaker with a minimum open contact gap of 3mm must be used for proper installation. (CE countries)

WARNING

During the warranty period if a customer elects to use a non-original part or modifies an original part purchased from MagiKitch'n and/or its Authorized Service and Parts (ASAP) companies, this warranty will be void. In addition, MagiKitch'n and its affiliates will not be liable for any claims, damages or expenses incurred by the customer which arises directly or indirectly, in whole or in part, due to the installation of any modified part and/or received from an unauthorized service center.

WARNING

This appliance, when installed, must be electrically grounded in accordance with local and national codes. In North America, in the absence of local codes, with the National Electrical Code, ANSI/NFPA 70, or the Canadian Electrical Code, CSA C22.2, as applicable.

WARNING

Adequate means must be provided to LIMIT the movement of this appliance without depending on the electrical cord connection. Single appliances equipped with legs must be stabilized by installing anchor straps. All appliances equipped with casters must be stabilized by installing restraining chains.

WARNING

DO NOT alter or remove structural material on the appliance to accommodate placement under a ventilation hood.

WARNING

This appliance is intended for professional use only and should be operated by fully trained and qualified personnel.

WARNING

If the supplied power cord is damaged, it must be replaced by a MagiKitch'n Authorized Service and Parts (ASAP) company technician or a similarly qualified person in order to avoid a hazard.

WARNING

All power supplies must be disconnected before servicing, maintaining or cleaning this appliance.

WARNING

The appliance is NOT jet stream approved. DO NOT clean the appliance with a water jet.

WARNING

DO NOT attempt to move this appliance or transfer hot liquids from one container to another when the unit is at operating temperature or filled with hot liquids. Serious personal injury could result if skin comes in contact with the hot surfaces or liquids.

WARNING

DO NOT sit or stand on this appliance. The appliance's front panel, cook plate, splash back, side, workshelf not a step. Serious injury could result from slipping, falling or contact with hot surfaces or liquids.

WARNING

NEVER use the appliance as a step for cleaning or accessing the ventilation hood. Serious injury could result from slips, trips or from contacting hot surfaces or liquids.

WARNING

DO NOT use the appliance unless it is properly secured to a table, stand or freezer / refrigerated base suited to handle the weight of the entire appliance.

WARNING

DO NOT operate appliance unless all panels and access covers are attached correctly.

WARNING

It is recommended that this appliance be inspected by a qualified service technician for proper performance and operation on a yearly basis.



WARNING

Some surfaces of this appliance can become extremely hot during normal operation. The following symbol is affixed to the appliance to remind users to exercise caution and to always use personal safety when operating this appliance.



WARNING

The following symbol is affixed to the appliance to remind users that, in order to safely operate this appliance, it is important that the user read and understand the instruction manual before attempting to operate this appliance.



WARNING

This appliance is not intended for use by persons (including children) with reduced physical, sensory or mental capabilities, or lack of experience and knowledge, unless given supervision or instruction concerning use of the appliance by a person responsible for their safety.

1. INSTALLATION SECTION	4
1.1. CHECKING YOUR NEW GRIDDLE	4
1.2. INSTALLATION CLEARANCES	4
1.3. INSTALLATION SETUP	5
1.3.1. Counter Use With Legs	5
1.3.2. Counter Use Without Legs	5
1.3.3. For Use On Optional Equipment Stand	5
1.3.4. Leveling Instructions	6
1.4. ELECTRICAL CONNECTIONS	7
1.5. VENTILATION AND FIRE SAFETY SYSTEMS	8
2. OPERATION SECTION	8
2.1. OPERATION	8
2.1.1. Solid State And Electric Thermostat Appliances	8
2.2. INITIAL STARTUP	8
2.2.1. Griddle Surface Seasoning	9
2.2.2. Surface Temperature Check	9
2.3. SHUTDOWN PROCEDURE	9
2.3.1. Solid State And Electric Thermostat Appliances	9
3. THERMOSTAT CALIBRATION SECTION	9
3.1. CALIBRATION PROCEDURES	9
3.1.1. Electric Thermostat	9
3.1.2. Solid State Thermostat	10
4. BASIC OPERATION	10
4.1. OPERATIONAL HELPFUL HINTS	10
4.2. SUGGESTED COOKING TIMES AND TEMPERATURES	10
5. CLEANING & MAINTENANCE SECTION	11
5.1. DAILY CLEANING	11
5.2. GRIDDLE SURFACE CLEANING, END OF SHIFT	11
5.2.1. Plain Steel Cooking Surface	12
5.2.2. Chrome Plated Cooking Surface	12
5.3. MONTHLY MAINTENANCE	12
5.3.1. Monthly Preventative Maintenance	12
5.4. ANNUAL/PERIODIC PREVENTATIVE MAINTENANCE AND INSPECTION	12
5.4.1. Safety Evaluation	12
5.4.2. Mechanical Inspection	12
5.4.3. Control Box & Electrical Components	13
5.4.4. Systems Operation Inspection	13
5.5. VENTILATION HOOD	13
5.6. TROUBLE SHOOTING CHARTS	14
5.6.1. Cooking Performance	14
5.6.2. Operating Performance	14
6. ACCESSORIES	15
6.1. STANDARD	15
6.2. OPTIONAL	15
6.2.1. Service Shelves, Front	15
6.2.2. Cutting Boards	16
6.2.3. Warming Shelves, Rear	17
6.2.4. Equipment Stands	18
6.2.5. Miscellaneous	19
7. NOTES PAGE	21

1. Installation Section

1.1. Checking Your New Griddle

Your new griddle has been carefully packed into one crate. Every effort has been made to ensure that your new griddle is delivered to you in perfect condition. As you unpack your new appliance, inspect each of the pieces for damage. If something is damaged, Contact the shipper immediately; the shipper is only responsible for 15 days after delivery. Check the packing list enclosed with your griddle to ensure that you have received all the parts to the griddle. If you are missing any parts, contact the dealer from whom the griddle was purchased.

In the provided spaces on the cover of this manual, fill in the Model No., Serial No., and the date the appliance was purchased. The Information is located on the data plate on the inside cabinet wall, see Figure 1 below. Keep this information in a safe place so it can be referred to in the future.

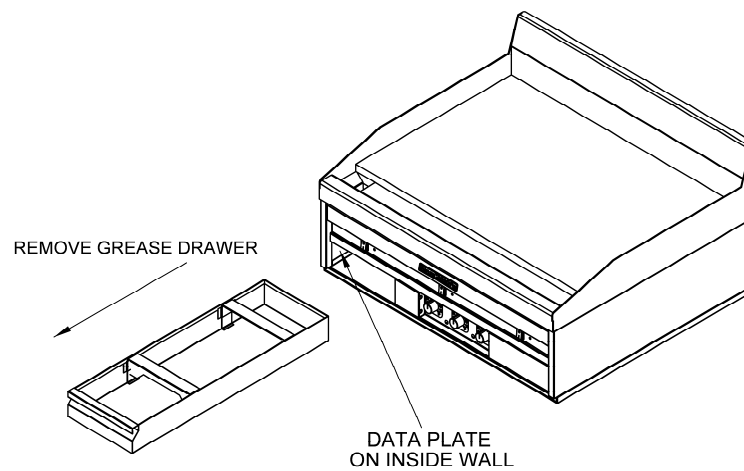

Figure 1

1.2. Installation Clearances

Your new MagiKitch'n Griddle needs clearance around it for proper operation. Adequate clearances allow for servicing. The clearances shown below are for installation in combustible and non-combustible construction. Ensure that all clearances stated on the data plate and in the clearance section of this manual are strictly followed.

Location	Combustible Construction Inches (Centimeters)	Non-Combustible Construction Inches (Centimeters)
Cabinet Back	8.0 (20.4)	8.0 (20.4)
Cabinet Sides	2.0 (5.0)	0.0 (0.0)

Table 1

1.3. Installation Setup

To Start uncrate appliance and locate installation accessories shipped with the appliance.

1.3.1. Counter Use With Legs

CAUTION

To prevent equipment damage, **DO NOT** tilt your MagiKitch'n griddle on only two legs, or on its sides.

(See Figure 2) A set of 4" (10 cm) legs is shipped with the appliance (unless appliance was specifically ordered without legs). A threaded receptacle is located near each corner of the underside of the base of the appliance, on appliances 48" (122 cm) and wider there are threaded receptacles in the front and rear center of the base. Each leg has a similar mating thread. Raise appliance sufficiently to allow legs to be screwed tightly into receptacles. The appliance can be leveled by adjusting the feet at the bottom of the leg assembly. This can be done by turning the foot in or out to lower or raise each corner as needed.

NOTICE

4" (10 cm) Legs should not be used with the optional Equipment Stand.

1.3.2. Counter Use Without Legs

(See Figure 3) The appliance must be sealed to the counter to comply with applicable sanitation standards. A bead of silicone sealant, approximately 1/2 inch (1.3 cm) wide, is to be applied to the bottom of the unit approximately 1/4" (0.6 cm) in from the front, back and side edges. We suggest Dow Corning →, GE → or Permatex → silicone 'RTV' adhesive sealant or equivalent. (See NSF Basic Criteria C-2 for details where applicable).

1.3.3. For Use On Optional Equipment Stand

ATTENTION

Rear mounting brackets should be installed to the Equipment Stand prior to placing griddle on the stand.

CAUTION

Only two of the four supplied casters are equipped with a locking feature. Install the griddle so that the two locking casters are at the *front of the unit*. The casters should be **LOCKED** before the unit is placed into operation.

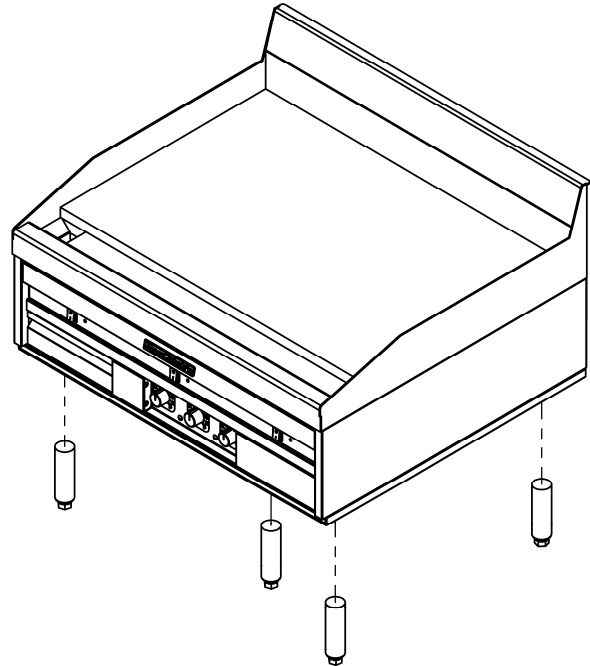

Figure 2

CAUTION

The appliance must be level to perform properly. Failure to level unit may result in improper performance of the appliance.

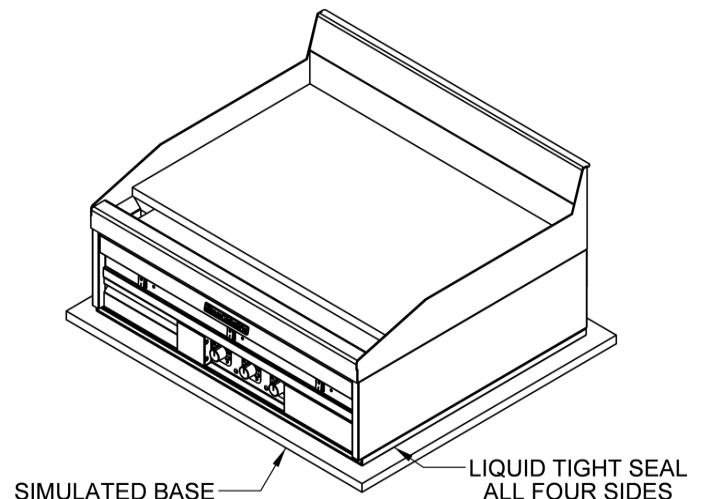

Figure 3

NOTICE

The larger units have 6 threaded receiving holes, but require only the four 1/2" bolts on each corner to mount the griddle.

1. Remove (4) existing 1/4-20 nuts and bolts from the rear corners of the equipment stand.
2. Align the 2 bolt holes on the rear corners of the stand with the 2 bolt holes on the rear mounting brackets. Orient the brackets as shown in Figure #4 on this page.
3. Install the provided rear mounting brackets (2) to the rear corners by using the existing 1/4-20 hardware that were removed in step 1, tighten securely.
4. Carefully place the griddle on the equipment stand.
5. Position the griddle so that the front edge of the base is flush with the front of the equipment stand. If the griddle is the only appliance to be mounted on the stand, then both sides of the griddle should be flush with the sides of the equipment stand.
6. When positioned properly, the threaded receiving holes in the griddle base should be aligned with mating clearance holes at the front of the equipment stand, and with the clearance holes in the rear mounting brackets. Install the provided 1/2" bolts and tighten securely.

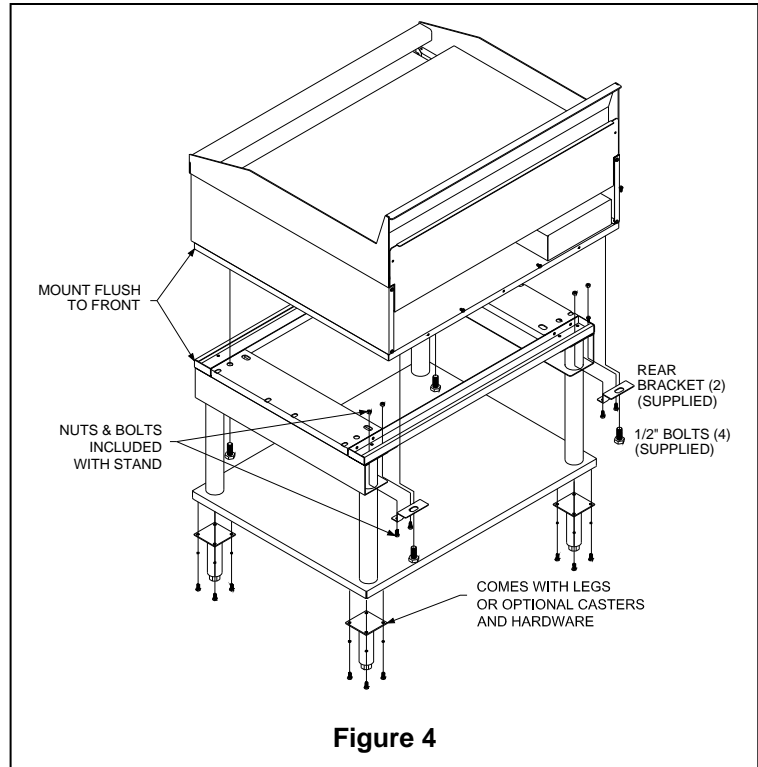

Figure 4

1.3.4. Leveling Instructions

NOTICE

Equipment stands are shipped from the factory with the legs or casters set to "Zero". Units should be leveled at time of installation, failure to do so could cause the griddle to operate improperly.

1. Identify the end or corner of the stand that needs to be raised, remove the weight load from the caster or leg to be leveled.
2. **Legs-** using a wrench, or pliers turn the leg bullet, See Figure 5, CCW to raise the height of the equipment stand. There is 1/2" to 3/4" (1.3 – 1.9 cm) of adjustment.
Castors- (For Stands shipped after May 2006) Using a Flat Head screwdriver, loosen the set screws of the caster to be leveled, See Figure 5. Turn the collar of the caster CCW to raise the height of the equipment stand. There is 1/2" to 3/4" (1.3 – 1.9 cm) of adjustment.

After leveling adjustment is complete, re-tighten set screws.

3. Repeat Step 2 for legs or casters that require leveling.
4. Check the levelness of the equipment, if necessary Repeat steps 1, 2, and 3.

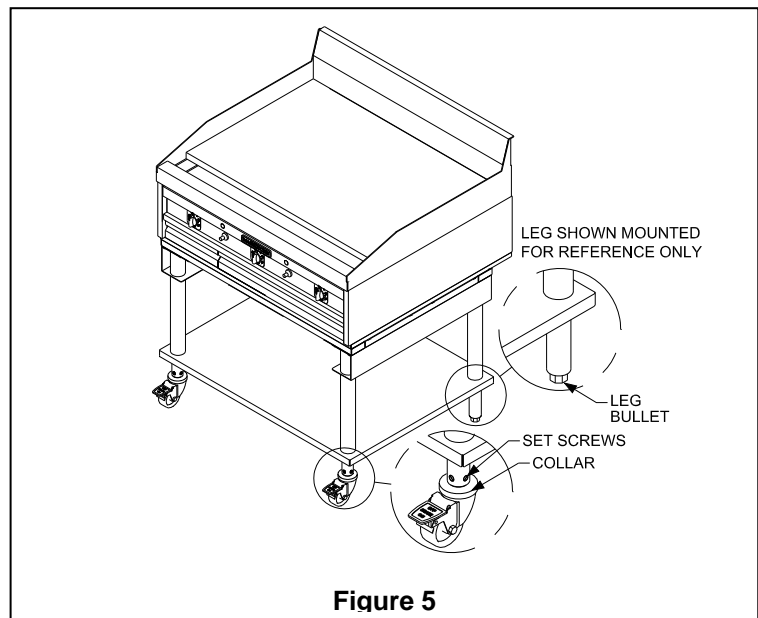

Figure 5

1.1. ELECTRICAL CONNECTIONS

It is advised that this power supply be plugged into a wall receptacle or hard wired into a circuit that is controlled by the ventilation control. This will prevent the appliance from being operated without the ventilator on.

Have qualified professional connect the power supply to the terminal block(s), if a cord is not supplied, according to their labeled leg (L1, L2, L3, ground and N as applicable). Access to the terminal blocks can be gained by first removing the grease drawer, then removing the lower rear and front panels (order of removal is shown in figure 7). This will require a Phillips head screwdriver and a 5/16 nut driver, wrench or ratchet. Minimum gauge copper wire is noted on the data plate.

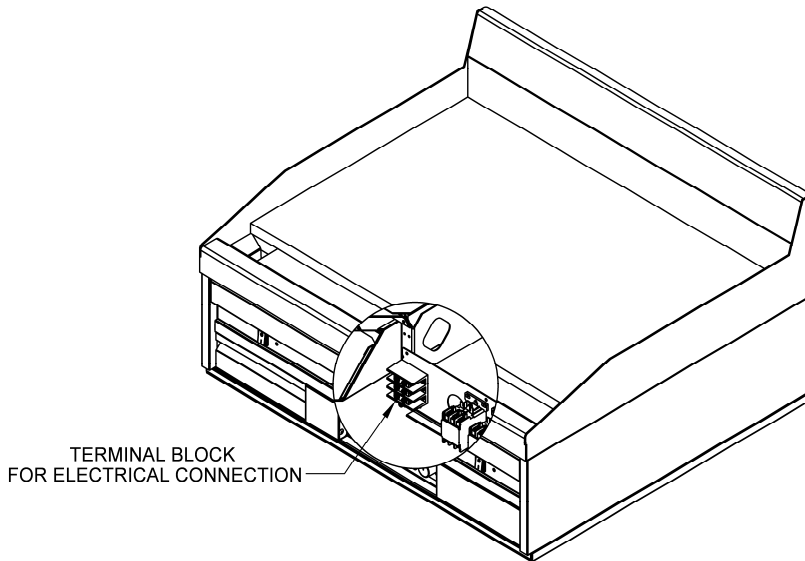

Figure 6

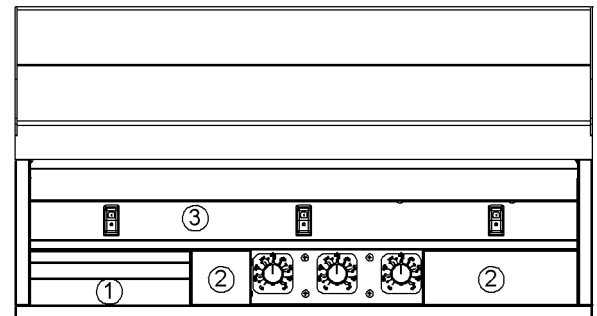



Figure 7

CAUTION
Connecting the appliance to the wrong power supply may damage the appliance and void the warranty.
WARNING
This appliance must be connected to a power supply having the same voltage and phase as specified on the data plate located on the wall inside the grease drawer chute.
WARNING
DO NOT attempt to connect the appliance to an electrical supply other than that indicated on the data plate. Electrical connection should be performed by qualified personnel.
WARNING
The electrical connection used by this appliance must comply with local codes. In the US, if there are no local codes that apply, refer to the National Electrical Code (NEC), ANSI/NFPA 70 for installation in the US. In Canada, refer to CSA Standard C22.2 and local codes. In all other cases, refer to local and national codes and regulations.
WARNING
The appliance must be grounded in accordance with local code; in North America, if there is no local code, comply with the NEC and ANSI/NFPA No. 70 latest edition (for US and Canadian installations). In all other cases, refer to local and national codes and regulations. To comply with European requirements, European models are equipped with an equalization-bonding clamp. An equalization bonding lead must be connected to this clamp to provide sufficient protection against potential difference. This clamp, located on the rear of the appliance is marked with the following universal symbol. 
WARNING
A country approved all pole circuit breaker with a minimum open contact gap of 3mm must be used for proper installation. (CE countries)

WARNING
This equipment must be installed so that the plug is accessible unless other means for disconnection from the power supply (e.g. a circuit breaker) is provided.
WARNING
If this appliance is permanently connected to fixed wiring, it must be connected by means of copper wires having a temperature rating of not less than 167°F (75°C).
WARNING
All copper wiring for this appliance must be made in accordance with the wiring diagram(s) located on the appliance.

1.2. VENTILATION AND FIRE SAFETY SYSTEMS

Your new appliance must have proper ventilation to function safely and properly. It is very important to install a fire safety system. Your ventilation system should be designed to allow for easy cleaning. Frequent cleaning and proper maintenance of the ventilation system and the appliance will reduce the chances of fire. Ventilation and fire safety systems must comply to local and national codes. In North America, NFPA96 will provide guidance on ventilation and fire safety systems.

2. Operation Section

Ensure that a proper installation has been performed on the appliance and that all warnings, cautions, and notices contained in this manual have been read, understood and adhered to before proceeding.

2.1. Operation

2.1.1. Solid State And Electric Thermostat Appliances

1. Turn the "I/O" switch to the " I " (ON) position for all desired thermostats to be operated.
2. Operate thermostats by turning knobs to the desired temperature. The "I/O" switch will illuminate when the thermostat calls for heat.

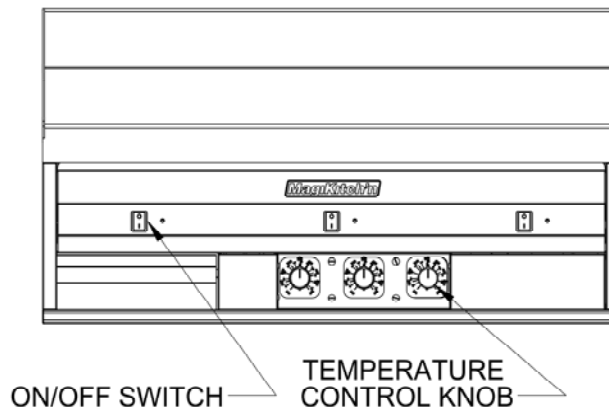

Figure 8

2.2. Initial Startup

NOTICE

New griddles should be carefully tempered and cared for in order to avoid possible damage. To break in a new griddle, do the following:

Wipe the griddle surface clean. A mild soapy water solution may be used to clean the surface, if this solution is used be sure to rinse thoroughly with potable water to eliminate any soap residue. Also it is important to wipe the griddle surface and surrounding areas to remove any standing water. Never allow water on a hot griddle surface.

Seasoning is not required on chrome plated cooking surfaces, but the following procedure may be performed to improve the non-stick qualities of the chrome plated cooking surface.

2.2.1. Griddle Surface Seasoning

1. To season the griddle, turn on all thermostat switches and set knobs to 200°F (93°C). As the unit heats to 200°F (93°C), apply a light film of cooking oil or beef suet over the entire cooking surface, wiping off any excess build up. This step may be repeated as necessary to apply an even coating on the griddle surface. Seasoning will help create and maintain a non-stick surface on your griddle.
2. Allow the seasoned surface to idle for one hour at 200°F (93°C), Then set the thermostats to your desired cooking temperature, once your griddle surface has reached temperature apply another coating of seasoning oil, wiping off any excess that may cause build up.

2.2.2. Surface Temperature Check

1. If available, place grill surface thermometer over each thermostat sensing probe 12" (30.5cm) from the front edge of the griddle surface. The first sensing probe is located 6" (15 cm) from the left side of the griddle, additional sensing probes are every 12" (30.5cm) to the right thereafter.
2. Heat the griddle to the desired cooking temperature; check the surface temperature reading on the grill thermometer. If necessary, adjust the thermostats that control any area of the surface that are not within +/- 15°F (8°C) of the thermostat setting. The procedure for adjusting the thermostats is in Section 3.

2.3. Shutdown Procedure

2.3.1. Solid State And Electric Thermostat Appliances

1. Turn "I/O" Switch to "O" position.
2. Allow griddle surface to cool normally.

3. Thermostat Calibration Section

Each control operates a set of three elements. The controls were set at the factory. However, if the griddle's surface temperature varies greatly from the setting on the thermostat knob, adjust the thermostat using the following procedure:

3.1. Calibration Procedures

3.1.1. Electric Thermostat

1. Turn all the control knobs to the desired temperature setting.
2. Wait 30 minutes (or 1 hour if griddle was cold) for surface to stabilize.
3. Place a reliable Griddle surface thermometer, or test instrument thermocouple, (able to register 300°F (149°C)), in the location above the thermostat being calibrated as described in section 2.2.2. Check the temperature every 5 minutes until the temperature stabilizes and does not change by more than 30°F (17°C) over a 15 minute span.
4. If the average temperature over any burner set is not within +/-15°F (8°C) of the knob setting (300°F (149°C)), adjust the corresponding thermostat. This is done by removing the knob, holding the

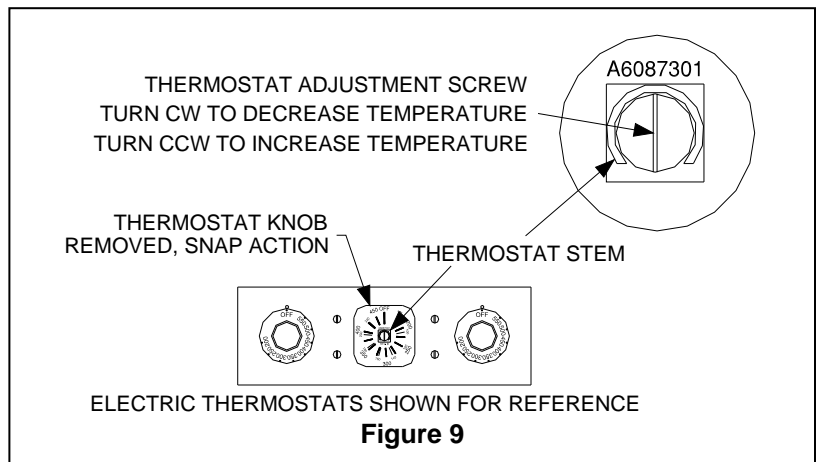

Basic Operation

MKE Series Electric Griddle

MagiKitch'n

thermostat knob stem, see picture above, (**do not allow the stem to turn or the temperature setting will not be accurate**), then turn the adjustment screw located within the center of the stem in small increments. Turn this screw counter clockwise to increase the temperature, and clockwise to decrease the temperature.

5. Check the temperature after 15 minutes and repeat adjustment as needed until the correct temperature is indication on the measuring instrument.

NOTICE

The adjustment screw on the thermostat is sealed by the Manufacturer to protect the calibration. It may be necessary to remove this seal to be able to adjust the thermostat.

3.1.2. Solid State Thermostat

1. Turn all the control knobs to the desired temperature setting.
2. Wait 30 minutes (or 1 hour if griddle was cold) for surface to stabilize.
3. Place a reliable Grill surface thermometer, or test instrument thermocouple, (able to register 300°F (149°C)), in the location above the thermostat being calibrated described in section 2.2.2. Check the temperature every 5 minutes until the temperature stabilizes and does not change by more than 30°F (17°C) over a 15 minute time period. You will need to remember the average temperature for the next step.

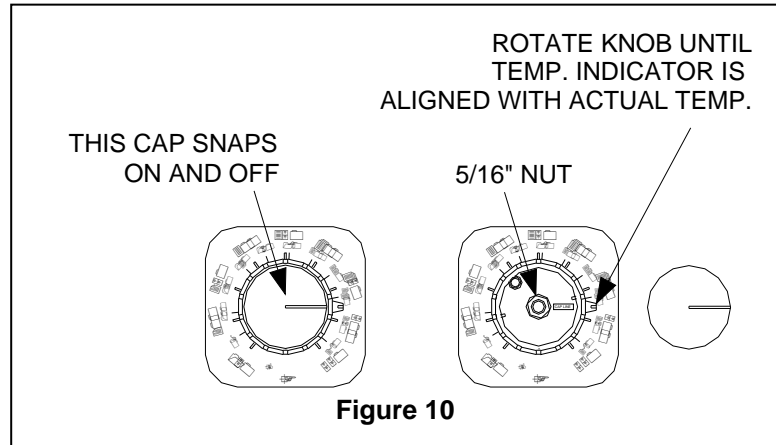

Figure 10

4. Carefully remove the cap on the thermostat knob with the white indicator line see picture this section. While holding the knob, loosen the 5/16" nut on the thermostat shaft, (**DO NOT REMOVE**), once the nut is loose the knob can be rotated so that the cap line marker is aligned with the actual temperature that the Grill surface thermometer is indicating.
5. Re-tighten the 5/16" nut while holding the knob in position, (do not allow the stem to turn or the temperature setting will not be accurate). Replace cap.

4. Basic Operation

4.1. Operational Helpful Hints

1. Each thermostat controls 12" (30.5cm) of griddle surface, whenever possible, use the leftmost or rightmost thermostats for the lowest cooking temperatures. The adjacent thermostats set at higher temperatures will effect centrally located thermostats.
2. For quicker thermostat response during heavy loading of the griddle, load product directly over the thermostat sensing probe. For slower periods of use, load product to one side of the sensing probe to limit possible overheating of unused griddle surface.
3. Whenever possible, rotate the location of where product is cooked, this will keep the entire 12" (30.5cm) of the controlled area at a more even temperature.
4. If any product sticking occurs, apply a thin coat of cooking oil to the surface before loading product.
5. When using spatulas or scrapers, it is **Highly Recommended** that the corners of the tools never strike the griddle surface with any force. This could cause damage to the surface that could collect food particles, and make it difficult to clean.

4.2. Suggested Cooking Times And Temperatures

NOTICE

The times and temperatures in this chart are suggestions only. Your experience with your own menu items will be your best guide to achieving the best food product.

Product	Temperature°F (°C)	Time
Breakfast Items		
Pancakes	375° (191°)	2 Minutes
French Toast	400° (204°)	4-5 Minutes
*Breakfast Potatoes	375°-400° (191°-204°)	15-20 Minutes
Eggs		
Scrambled	300° (149°)	3-4 Minutes
Sunny Side Up	225°-300° (107°-149°)	3-4 Minutes
Over Easy	250°-300° (121°-149°)	2-3 Minutes
Over Hard	225°-300° (107°-149°)	3-4 Minutes
Breakfast Meats		
Sausage, Link and Patty	350° (177°)	3 Minutes
Bacon	350° (177°)	2-3 Minutes
Canadian Bacon	350° (177°)	2-3 Minutes
Ham Steaks	375° (191°)	3-4 Minutes
Broiled Ham	375° (191°)	2 Minutes
Ham, Pre-Cooked	375° (191°)	2 Minutes
Fish		
Salmon	350° (177°)	6-8 Minutes
Hamburgers		
2 Patties per Lb.	350° (177°)	6-8 Minutes
4 Patties per Lb.	350° (177°)	4-6 Minutes
6 Patties per Lb.	350° (177°)	3-4 Minutes
Steaks, Etc.		
1/2"-3/4" Thick, Medium	375° (191°)	5-7 Minutes
3/4"-1" Thick, Medium	375° (191°)	8-10 Minutes
Beef Tenderloin	400° (204°)	3-4 Minutes
Sandwiches, Etc.		
Grilled Cheese	375° (191°)	3-4 Minutes
Hot Dogs	325° (163°)	2-3 Minutes

Table 2

***Based on cubed potatoes brought to a boil then cooled prior to finishing on griddle. To reduce burning and sticking of the potatoes coat the griddle surface with vegetable oil and turn potatoes frequently.**

5. Cleaning & Maintenance Section

5.1. Daily Cleaning

NOTICE

Do not use Grill Bricks, Grill Screens, or any other type of abrasive material on your MagiKitch'n Chrome Griddle Surface. USING ABRASIVE MATERIALS WILL VOID YOUR WARRANTY.

1. Clean the griddle surface often to prevent sticking and poor food product quality. Scrape the griddle plate regularly with a scraper intended for your type of griddle surfaces to remove all surface grease and food debris.
2. Clean and wipe out grease chutes.
3. Wipe down the exterior, the sides and front of the griddle are stainless steel, any stainless steel cleaner can be used to clean these surfaces.
4. Remove and empty grease box(es) of any and all debris, also wipe down the inside of the grease box compartment for food particles that may have come free from the grease box.

NOTICE

The grease box is designed to contain grease run off from the griddle surface. The grease box should NEVER be allowed to overflow, and should be emptied accordingly and grease disposed of properly.

5.2. Griddle Surface Cleaning, End Of Shift

NOTICE

Wear protective gloves and clothing when cleaning the appliance, HOT Surfaces may cause personal injury.

5.2.1. Plain Steel Cooking Surface

1. Scrape griddle surface completely with a scraper to remove grease and food debris.
2. Use a grill brick or grill screen to clean any heavy build up of carbon from the griddle surface. Never use steel wool pads, small fibers may be left behind on the cooking surface.
3. When griddle surface is cool, polish surface with MagiKleans'r, or similar type non-abrasive, non-caustic cleaners that are approved for stainless steel.
4. It may be necessary to season the grill again after this cleaning.

5.2.2. Chrome Plated Cooking Surface

NOTICE

Do not use Grill Bricks, Grill Screens, or any other type of abrasive material on your MagiKitch'n Chrome Griddle Surface. USING ABRASIVE MATERIALS WILL VOID YOUR WARRANTY.

1. Scrape griddle surface completely with supplied scraper to remove grease and food debris.
2. When griddle surface is cool, scrub the chrome surface with the supplied palmetto cleaning brush and cool water.
3. Shine the chrome griddle cooking surface with MagiKleans'r, water and a soft cloth.
4. Rinse with clean water and wipe away any residue with a dry cloth.

5.3. Monthly Maintenance

NOTICE

Regular maintenance of your MagiKitch'n griddle is Recommended to keep the appliance operating properly.

5.3.1. Monthly Preventative Maintenance

Food debris and grease can buildup in and around the griddle . Performing the monthly preventative maintenance steps below will keep your equipment safe and at peak performance. If you are producing high quantities of grilled foods, it may be necessary to clean these components more than once a month

- ✓ Use a grill surface thermometer to make sure thermostats are operating properly.
- ✓ Make sure that all electrical connections have not been tampered with or damaged.
- ✓ Check to see that the ventilation hood and make up air systems are working properly.
- ✓ Inspect griddle surface for any visible damage.

5.4. Annual/Periodic Preventative Maintenance and Inspection

This section should ONLY be performed by a qualified service technician as part of a regular kitchen maintenance program. This inspection should take place a minimum of once a year by an Authorized Service Technician recommended by MagiKitch'n. It may be necessary perform this inspection more than once a year.

5.4.1. Safety Evaluation

- ✓ Check all electrical connections, and verify that the griddle retention/lanyard system is in place.
- ✓ Check for food debris and grease migration in and around the cabinet of the appliance.
- ✓ Check legs/casters, and ensure all nuts and bolts are secured. (If Equipped)
- ✓ Check all exposed wiring connections, switches and indicator lights.

5.4.2. Mechanical Inspection

- ✓ Check griddle surface for damage, rust, and any cracks in the chrome plating if applicable.
- ✓ Check grease box for leaks.
- ✓ Check for grease and water migration, clean as necessary.
- ✓ Check ventilation hood drain cup and filters, clean as necessary.
- ✓ Check vents for foreign debris.
- ✓ Check for loose parts.
- ✓ Check for missing parts and fasteners, replace as necessary.

5.4.3. Control Box & Electrical Components

- ✓ Verify amp-draw is within range as compared to the information on the data plate.
- ✓ Verify that heating contactors are in good condition. Check for worn or pitted contacts. Verify that wires are tight and in good condition.
- ✓ Verify that all components (transformer, terminal block, relays, etc...) are in good condition. Verify that wires are tight and in good condition.
- ✓ Verify enclosures are free of leaks. Check for water stains and wet surfaces.
- ✓ Verify that the covers and panels are intact and provide a safe condition. Check for loose parts.
- ✓ Verify power cord is in good condition. Check for frayed or exposed wires.

5.4.4. Systems Operation Inspection

- ✓ Check all wire terminations, check for broken, or frayed wires.
- ✓ Check temperature calibration.
- ✓ Check thermostat operation and features for proper operation.
- ✓ Verify all components are in good physical condition.
- ✓ Ensure that all components are clean, and do not have any grease or water damage.

5.5. Ventilation Hood

Proper ventilation hood operation is very important for the correct operation of this appliance and the safety of personnel. The ventilation hood should be inspected at the time of installation of this appliance to insure that it will operate properly in conjunction with the appliance. Perform a regular schedule of examination, in accordance with local and national codes. In North America, ANSI/NFPA 96 latest edition and/or local codes must be followed.

5.6. Trouble Shooting Charts

The following charts may help to eliminate any basic operational problems that you may be experiencing with your appliance. Locate the problem on the left side of the chart, and cross-reference with the possible cause. Once the problem has been identified take the appropriate action to rectify the problem.

5.6.1. Cooking Performance

If you are having poor cooking performance or any inconsistencies in product quality, please refer to the following chart for help.

		Possible Cause							
		Heat Set too High	Moisure In Food Turning To Stream	Griddle Surface Dirty or Un Seasoned	Cook Times Too Short	Product Shelf Life Expired	Improperly Stored Product	Excessive Oil Or Grease On Griddle Surface	Heat Set Too Low
Problem	Excessive Smoke From Fat	X	X						
	Product Sticking	X		X	X				
	Product Edges Burning	X		X	X				
	Product Centers Underdone	X				X			
	Greasy Or Undesirable Flavor						X	X	X
	Grease Build Up On Griddle Surface	X		X				X	

Table 3

5.6.2. Operating Performance

The following chart may help to diagnose any operational issue you may be experiencing with your appliance. Some issues may **REQUIRE** that a qualified service technician perform the repairs. If a qualified service technician is required, please contact the factory service department.

		Possible Cause				
		Unit Not Plugged In (if so equipped)	Power Switch Off	Thermostat "OFF"	Thermostats Not Calibrated	Thermostat Failure
Problem	Power Switch Will Not Illuminate	X	X	X		X
	Griddle Will Not Heat UP	X	X	X		X
	Inconsistent Surface Temperatures				X	X
	Griddle Stays Hot or Overheats				X	X

Table 4
NOTICE

All parts and service for your MagiKitch'n griddle should be ordered and installed by a MagiKitch'n Authorized Service and Parts (ASAP) dealer. Failure to do so might result in the warranty being voided.

6. Accessories

6.1. Standard

All plain steel and chrome plated griddles are shipped with a set of 4" (10 cm) adjustable legs. The appliance also comes equipped from the factory with a manual gas shutoff valve, and the specified gas regulator for the model and gas type purchased.

Each MKE chrome surfaced griddle is equipped with a Chrome Kit which includes a cleaning brush, cleaning powder, spatula, scraper, and scraper blade replacements. See the table below for Re-Order Part Nos.

Chrome Griddle Accessories	
Magi Kleans'r	Part No. 9825-1525101
Palmetto Brush	Part No. 9825-1524901
Spatula, (Chrome Surface)	Part No. 9825-1525001
Scraper, (W/ Blade and Cover)	Part No. 9825-1528001
Replacement Blades	Part No. 9825-1528002

Table 5

Using MagiKitch'n chrome griddle accessories are important to maintaining the life of the griddle's chrome surface

6.2. Optional

To order accessories for your griddle, call your local MagiKitch'n dealer for prices and availability. The list of available accessories for your new appliance will give you the flexibility to customize your griddle to the best fit for your operational requirements.

This section will show you a variety of front and rear work shelves, cutting boards, equipment stands, and other accessories to provide you with an efficient working appliance.

6.2.1. Service Shelves, Front

Shelf Model	MKG24	MKG36	MKG48	MKG60	MKG72
8" Service Shelf, W/O Towel Bar	5125-1511601-C	5125-1511602-C	5125-1511603-C	5125-1511610-C	5125-1511611-C
*10" Service Shelf, W/O Towel Bar	5125-1511604-C	5125-1511605-C	5125-1511606-C	5125-1511612-C	5125-1511613-C
*12" Service Shelf, W/O Towel Bar	5125-1511607-C	5125-1511608-C	5125-1511609-C	5125-1511614-C	5125-1511615-C
8" Service Shelf, W/ Towel Bar	5225-1511701-C	5225-1511702-C	5225-1511703-C	5225-1511710-C	5225-1511711-C
*10" Service Shelf, W/ Towel Bar	5225-1511704-C	5225-1511705-C	5225-1511706-C	5225-1511712-C	5225-1511713-C
*12" Service Shelf, W/ Towel Bar	5225-1511707-C	5225-1511708-C	5225-1511709-C	5225-1511714-C	5225-1511715-C
Towel Bar Only	5225-1511801-C	5225-1511802-C	5225-1511803-C	5225-151804-C	5225-1511805-C

Table 6

10" and 12" service shelves are also available with pan cutouts. Consult factory for sizes and availability.

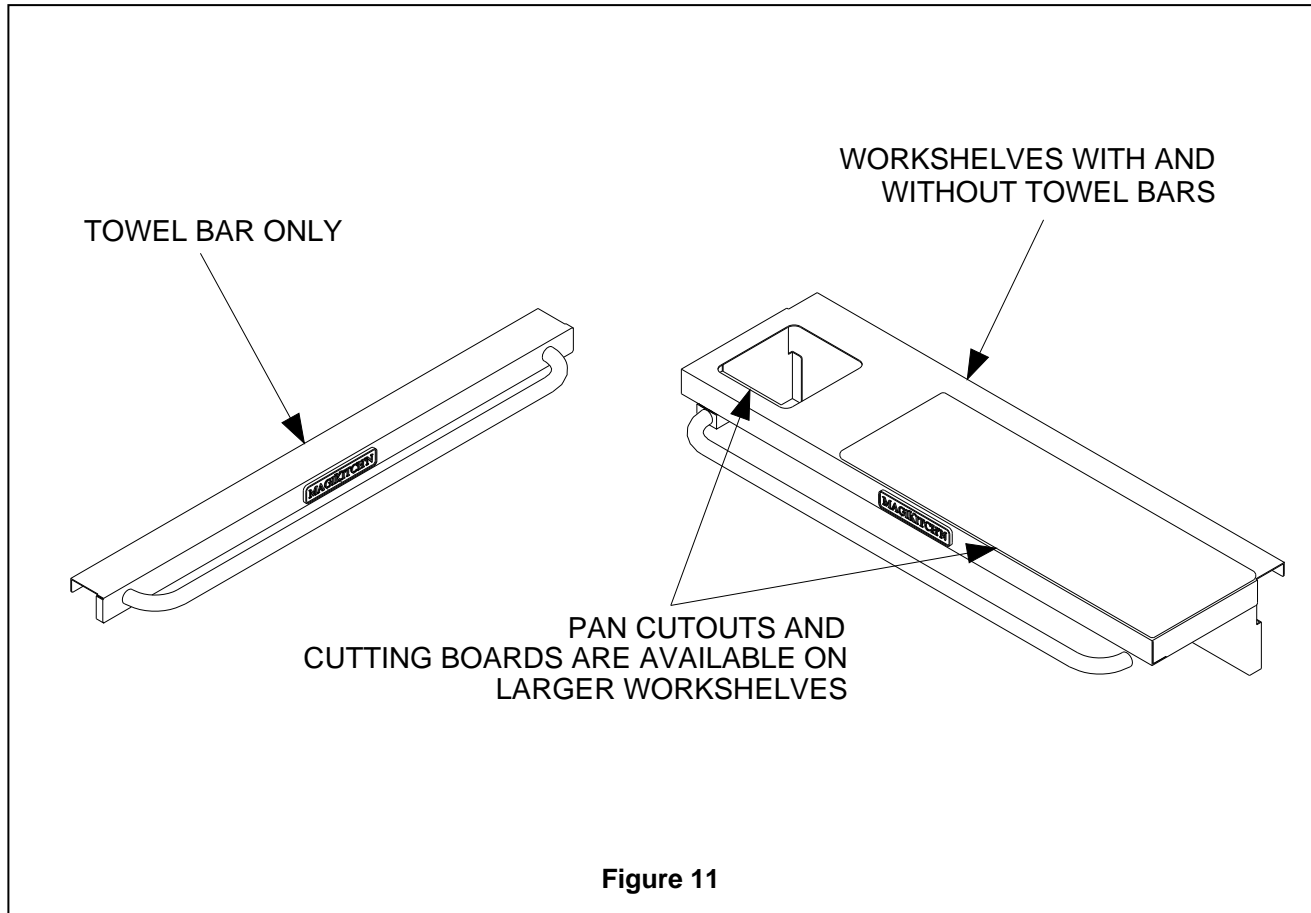

6.2.2. Cutting Boards

Size	Part No.
8" X 12" Cutting Board	1604-0643600-C
8" X 24" Cutting Board	1604-0643700-C
8" X 48" Cutting Board	1604-0643800-C
8" X 72" Cutting Board	1604-0643900-C

Table 7

Other sizes are available, consult factory for size, price, and availability.

6.2.3. Warming Shelves, Rear

Shelf Model	Part No.
C/A, Shelf Rear MKG24	5225-1535701-C
C/A, Shelf Rear MKG36	5225-1535702-C
C/A, Shelf Rear MKG48	5225-1535703-C
C/A, Shelf Rear MKG60	5225-1535704-C
C/A, Shelf Rear MKG72	5225-1535705-C

Table 8

Shelf Kits can be attached to existing models. The Stainless Steel shelf is removable from the shelf framework for easier cleaning if necessary.

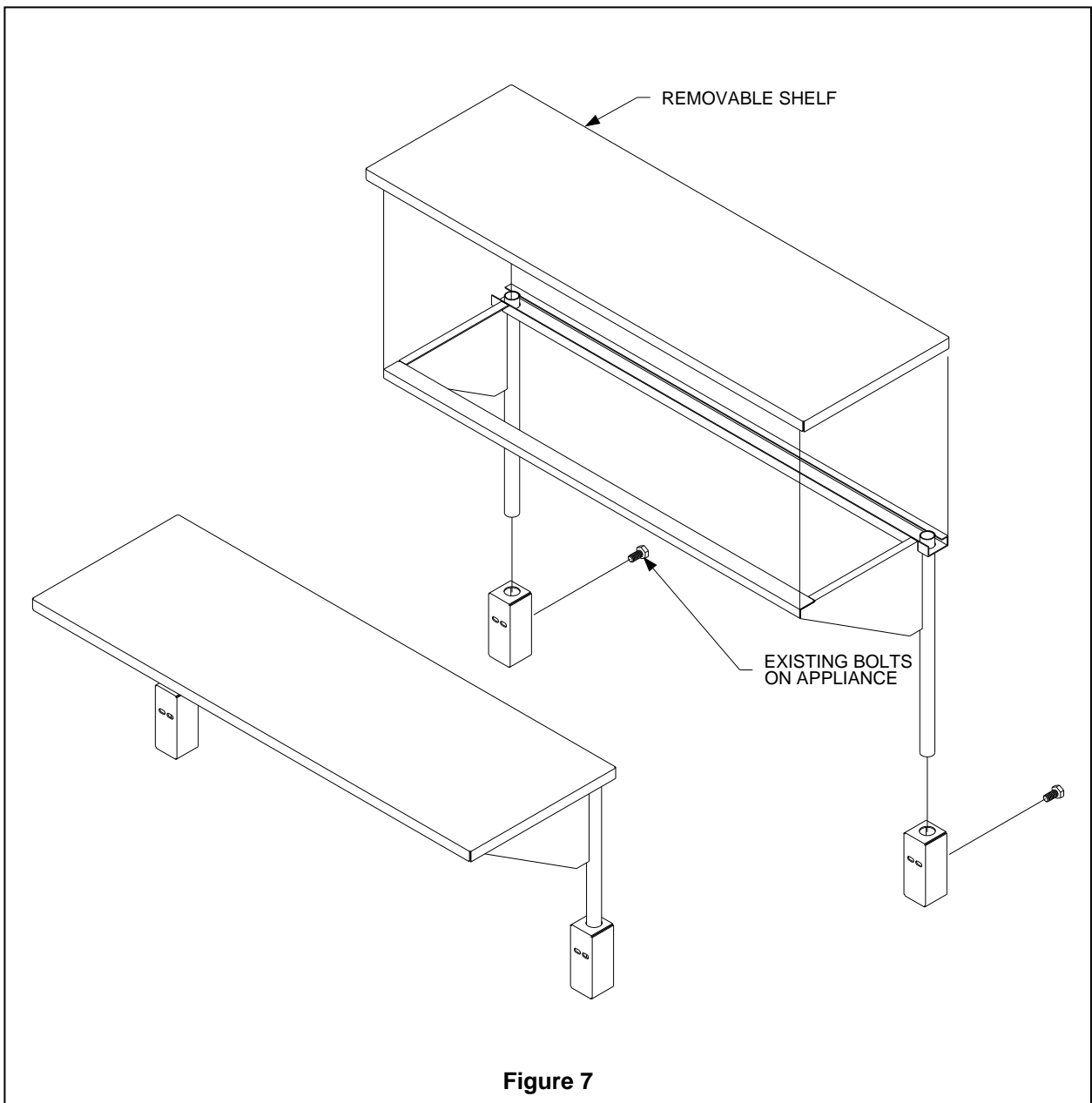

Figure 7

6.2.4. Equipment Stands

Equipment stands can be ordered with legs or casters (stands with casters shipped after May 2006 are equipped with adjustable casters).

NOTE:

It should also be noted that when ordering an equipment stand for your MKE appliance, you will also need to order and MKE Joining Kit, Part No. 7225-1512101.

Equipment Stand Model	Part No.
MKG24, W/ Legs	5225-1512001-C
MKG24, W/ Casters	5225-1512002-C
MKG36, W/ Legs	5225-1512005-C
MKG36, W/ Casters	5225-1512006-C
MKG48, W/ Legs	5225-1512007-C
MKG48, W/ Casters	5225-1512008-C
MKG60, W/ Legs	5225-1512009-C
MKG60, W/ Casters	5225-1512010-C
MKG72, W/ Legs	5225-1512011-C
MKG72, W/ Casters	5225-1512012-C

Table 9

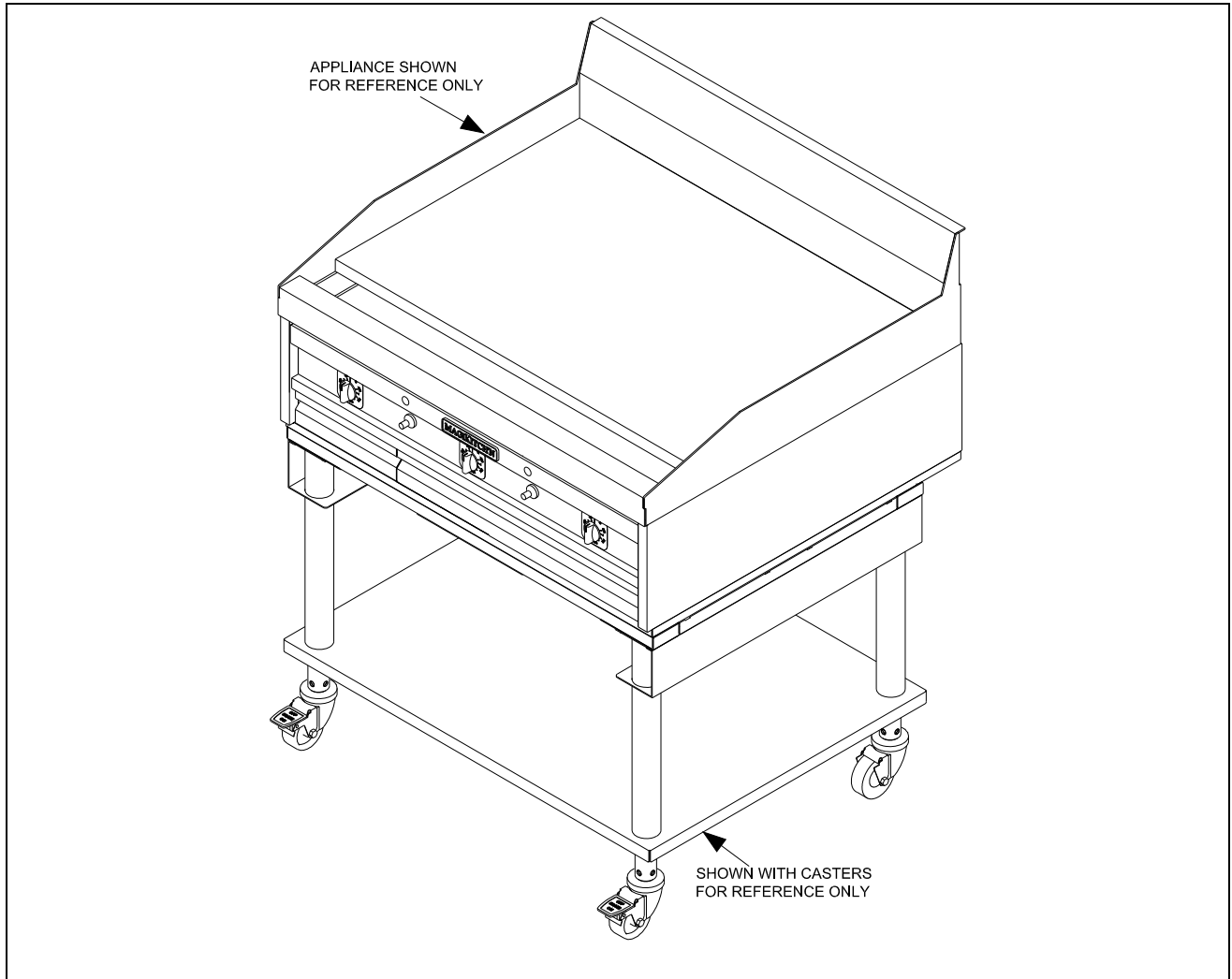

Figure 13

Equipment stands may be used to hold multiple MKE Griddles. They are also compatible with MagiKitch'n Series 600 APM Charbroilers.

6.2.5. Miscellaneous

Your appliance can also be used with the following miscellaneous accessories so you can customize your operation to your specific demands.. The wall spacers listed below insure that you cannot push the appliance too close to the rear wall. The Utensil box gives you a handy location to store your cooking tools. The Utensil box does not interfere with any controls, and can be moved from one end of the griddle to the other without the use of tools.

Accessory	Part No.
6" Wall Spacer, LH MKG	5425-1526701-C
6" Wall Spacer, RH MKG	5425-1526702-C
Utensil Box, MKG	9825-1532501-C
Utensil Box, MKG Towel Bar Only	9825-1532502-C

Table 10

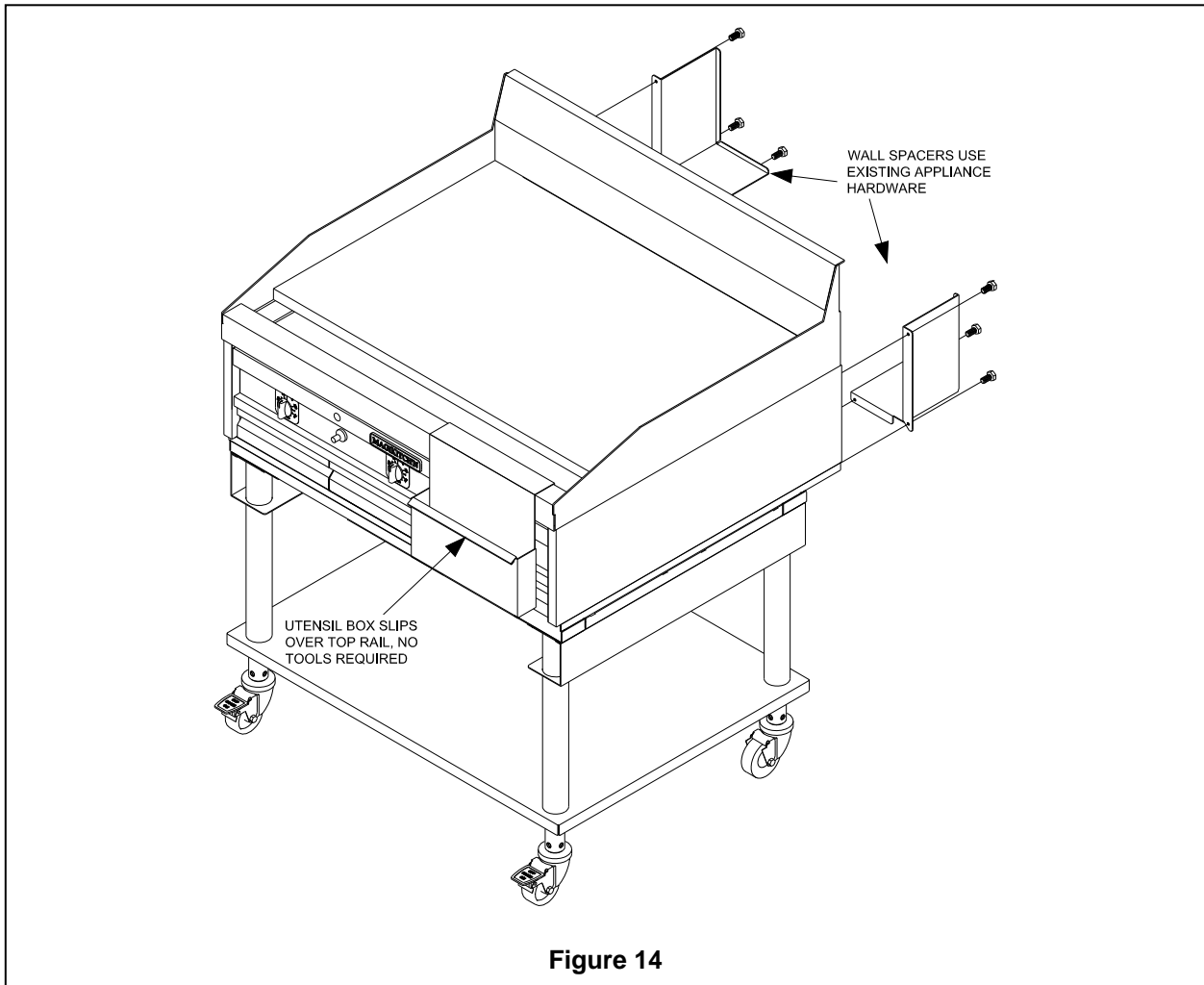

7. Notes Page

This Page Intentionally Left Blank

This Page Intentionally Left Blank



In the event of problems with or questions about your order, please contact the MagiKitch'n factory at:

(603) 225-6684 World Wide
www.magikitchn.com

In the event of problems with or questions about your equipment, please contact the MagiKitch'n Authorized Service and Parts representative (ASAP) covering your area, or contact MagiKitch'n at the numbers listed to the left.

MAILING ADDRESS – P.O. BOX 501, CONCORD, NH 03302-0501
SHIPPING ADDRESS – 10 FERRY ST., CONCORD, NH 03301