



**IMPORTANT FOR FUTURE REFERENCE**  
Please complete this information and retain this manual for the life of the equipment:

Model #: \_\_\_\_\_

Serial #: \_\_\_\_\_

Date Purchased: \_\_\_\_\_

**ENGLISH**

**Installation & Operation Manual**  
**MKG24, MKG36, MKG48, MKG60 & MKG72**  
**All Options**  
**Built After August 1, 2005**

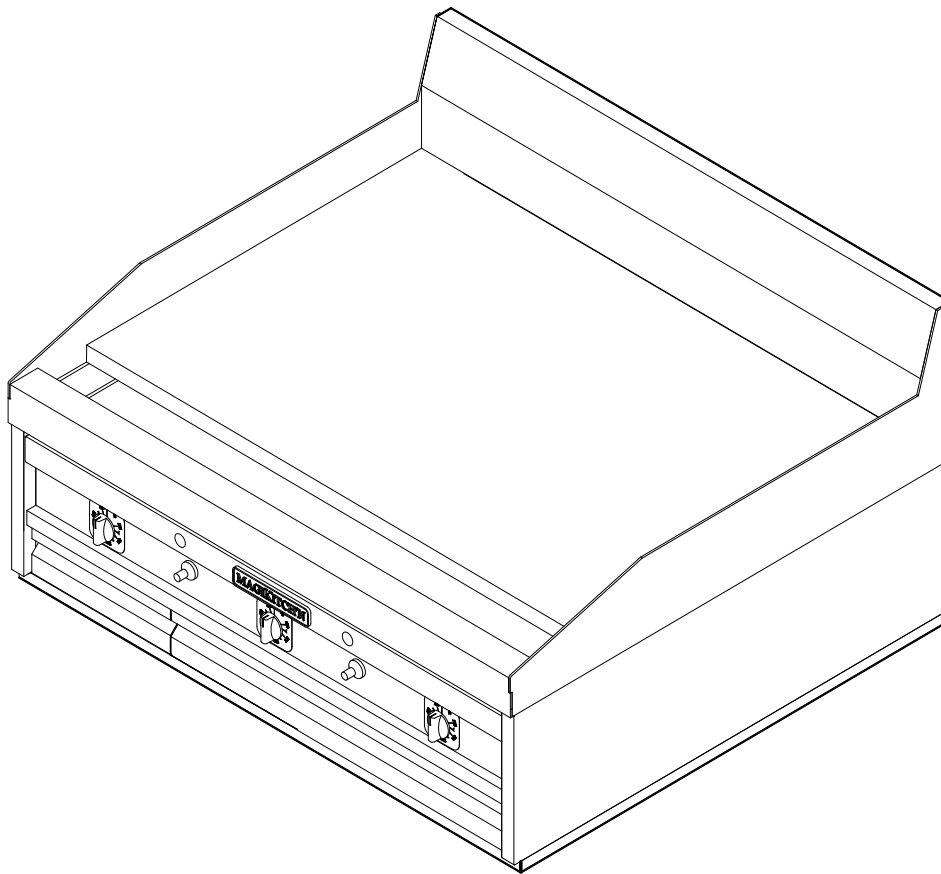

# TO THE PURCHASER, OWNER AND STORE MANAGER

**Please review these warnings prior to posting them in a prominent location for reference.**

## TO THE PURCHASER

Post in a prominent location the instructions to be followed in the event that an operator smells gas. Obtain this information from your local gas supplier.

### WARNING

DO NOT store or use gasoline or other flammable vapors and liquids in the vicinity of this or any other appliance. Do not spray aerosols in the vicinity of this appliance when it is in operation.

### WARNING

Improper installation, alteration, service or maintenance can cause property damage, injury or death. Read the installation, operating and maintenance instructions thoroughly before installing or servicing this appliance.

### WARNING

Installation, maintenance and repairs should be performed by a MagiKitch'n Authorized Service and Parts (ASAP) company technician or other qualified personnel. Installation, maintenance or repairs by unauthorized and unqualified personnel will void the warranty.

### WARNING

Installation and all connections must be made according to local codes in force. In the absence of local codes in North America, the installation must conform with the National Fuel Gas Code, ANSI Z223.1/NFPA 54 or the Natural Gas and Propane Installation Code CSA B149.1 as applicable. In Australia, the appliance must be installed in compliance with AS/NZS 5601.

### WARNING

During the warranty period if a customer elects to use a non-original part or modifies an original part purchased from MagiKitch'n and/or its Authorized Service and Parts (ASAP) companies, this warranty will be void. In addition, MagiKitch'n and its affiliates will not be liable for any claims, damages or expenses incurred by the customer which arises directly or indirectly, in whole or in part, due to the installation of any modified part and/or received from an unauthorized service center.

### WARNING

This appliance, when installed, must be electrically grounded in accordance with local codes, or in the absence of local codes, with the National Electrical Code, ANSI/NFPA 70, or the Canadian Electrical Code, CSA C22.2, as applicable.

### WARNING

Adequate means must be provided to limit the movement of this appliance without depending on the gas or electrical cord connection. Single appliances equipped with legs must be stabilized by installing anchor straps. All appliances equipped with casters must be stabilized by installing restraining chains, or equivalent means.

### WARNING

An appliance equipped with casters and a flexible gas line must be connected to the gas supply with a quick disconnect device. In North America this quick disconnect must comply with ANSI Z24.41. In Australia, the quick disconnect must comply with AS 4627.

### WARNING

DO NOT alter or remove structural material on the appliance to accommodate placement under a ventilation hood.

### WARNING

This appliance is intended for professional use only and should be operated by fully trained and qualified personnel.

### WARNING

If the appliance is equipped with a power cord and it is damaged, it must be replaced by a MagiKitch'n Authorized Service and Parts (ASAP) company technician, or a similarly qualified person in order to avoid a hazard.

### WARNING

The power supply must be disconnected before servicing, maintaining or cleaning this appliance.

### WARNING

The appliance is NOT jet stream approved. DO NOT clean the appliance with a water jet.

### WARNING

DO NOT attempt to move this appliance or transfer hot liquids from grease box to another container when the unit is at operating temperature or filled with hot liquids. Serious personal injury could result if skin comes in contact with the hot surfaces or liquids.

### WARNING

DO NOT sit or stand on this appliance. The appliance's front panel, cook plate, splash back, side, workshelf not a step. Serious injury could result from slipping, falling or contact with hot surfaces or liquids.

### WARNING

NEVER use the appliance as a step for cleaning or accessing the ventilation hood. Serious injury could result from slips, trips or from contacting hot surfaces or liquids.

### WARNING

DO NOT use the appliance unless it is properly secured to a table, stand or freezer / refrigerated base suited to handle the weight of the entire appliance.

### WARNING

This appliance is intended for indoor use only.

### WARNING

DO NOT operate appliance unless all panels and access covers are attached correctly.

### WARNING

It is recommended that this appliance be inspected by a qualified service technician for proper performance and operation on a yearly basis.

### WARNING

There is an open flame inside this appliance. The unit may get hot enough to set nearby materials on fire. Keep the area around the appliance free from combustibles.

### WARNING

DO NOT supply the appliance with a gas that is not indicated on the data plate. If you need to convert the appliance to another type of fuel, contact your Equipment Supplier or a MagiKitch'n Authorized Service and Parts (ASAP) Company.

### WARNING

DO NOT use an open flame to check for gas leaks!

### WARNING

If gas flow to appliance is interrupted, or pilots extinguish, wait 5 minutes before attempting to re-light the pilot to allow any residual gas in appliance to dissipate.

### WARNING

Ensure that the appliance can get enough air to keep the flame burning correctly. If the flame is starved for air, it can give off a dangerous carbon monoxide gas. Carbon monoxide is a clear odorless gas that can cause suffocation.

### WARNING

In North America, gas appliances equipped with casters must be installed with connectors that comply with the Standard for Connectors for Movable Gas Appliances, ANSI Z21.69.CSA 6.16 Latest Edition. This connection should include a quick disconnect device that complies with the Standard for Quick Disconnect Devices for Use With Gas Fuel ANSI Z221.41.CSA 6.9 Latest Edition. In Australia, an appliance equipped with casters and a flexible gas line must be connected to the gas supply with a quick disconnect device that complies with AS 4627 and a restraining cable. The restraining cable must not exceed 80% of the length of the flexible gas line. Hose assemblies for use with cooking appliances must be certified as conforming with AS/NZS 1869 and be Class B or Class D type.

<b>1. INSTALLATION SECTION</b>	<b>4</b>
1.1. CHECKING YOUR NEW GRIDDLE	4
1.2. INSTALLATION CLEARANCES	4
1.3. GAS CONNECTION(S)	4
1.3.1. Fuel Type(s)	5
1.3.2. Quick Disconnect Connection	5
1.3.3. Fuel Supply Line and Leak Pressure Testing	5
1.4. VENTILATION AND FIRE SAFETY SYSTEMS	5
1.5. INSTALLATION SETUP	5
1.5.1. Counter Use With Legs	6
1.5.2. Counter Use Without Legs	6
1.5.3. For Use On Optional Equipment Stand	6
1.5.4. Leveling Instructions	7
1.6. FINAL GAS CONNECTION	8
1.6.1. Regulator Assembly	8
1.6.2. Gas Settings	8
<b>2. OPERATION SECTION</b>	<b>9</b>
2.1. LIGHTING INSTRUCTIONS	9
2.1.1. Snap-Action Thermostat Appliances	9
2.1.2. Solid State And Electric Thermostat Appliances	9
2.2. INITIAL STARTUP	10
2.2.1. Griddle Surface Seasoning	10
2.2.2. Surface Temperature Check	10
2.3. SHUTDOWN PROCEDURE	10
2.3.1. Snap Action Thermostat Appliances	10
2.3.2. Solid State And Electric Thermostat Appliances	10
<b>3. THERMOSTAT CALIBRATION SECTION</b>	<b>11</b>
3.1. CALIBRATION PROCEDURES	11
3.1.1. Snap Action And Electric Thermostat	11
3.1.2. Solid State Thermostat	11
<b>4. BASIC OPERATION</b>	<b>12</b>
4.1. OPERATIONAL HELPFUL HINTS	12
4.2. SUGGESTED COOKING TIMES AND TEMPERATURES	12
<b>5. CLEANING &amp; MAINTENANCE SECTION</b>	<b>13</b>
5.1. DAILY CLEANING	13
5.2. GRIDDLE SURFACE CLEANING, END OF SHIFT	13
5.2.1. Plain Steel Cooking Surface	13
5.2.2. Chrome Plated Cooking Surface	13
5.3. MONTHLY MAINTENANCE	13
5.3.1. Monthly Preventative Maintenance	13
5.4. ANNUAL/PERIODIC PREVENTATIVE MAINTENANCE AND INSPECTION	14
5.4.1. Safety Evaluation	14
5.4.2. Mechanical Inspection	14
5.4.3. Systems Operation Inspection	14
5.5. VENTILATION HOOD	14
5.6. TROUBLE SHOOTING CHARTS	15
5.6.1. Cooking Performance	15
5.6.2. Operating Performance	15
<b>6. ACCESSORIES</b>	<b>16</b>
6.1. STANDARD	16
6.2. OPTIONAL	16
6.2.1. Service Shelves, Front	16
6.2.2. Cutting Boards	17
6.2.3. Warming Shelves, Rear	18
6.2.4. Equipment Stands	19
6.2.5. Miscellaneous	20
<b>7. NOTES PAGE</b>	<b>21</b>

## 1. Installation Section

### 1.1. Checking Your New Griddle

Your new griddle has been carefully packed into one crate. Every effort has been made to ensure that your new griddle is delivered to you in perfect condition. As you unpack your new appliance, inspect each of the pieces for damage. If something is damaged, Contact the shipper immediately; the shipper is only responsible for 15 days after delivery. Check the packing list enclosed with your griddle to ensure that you have received all the parts to the griddle. If you are missing any parts, contact the dealer from whom the griddle was purchased. In the provided spaces on the cover of this manual, fill in the Model No., Serial No., and the date the appliance was purchased. The Information is located on the Data plate on the inside cabinet wall, see Figure 1 below. Keep this information in a safe place so it can be referred to in the future.

1

**FIGURE**

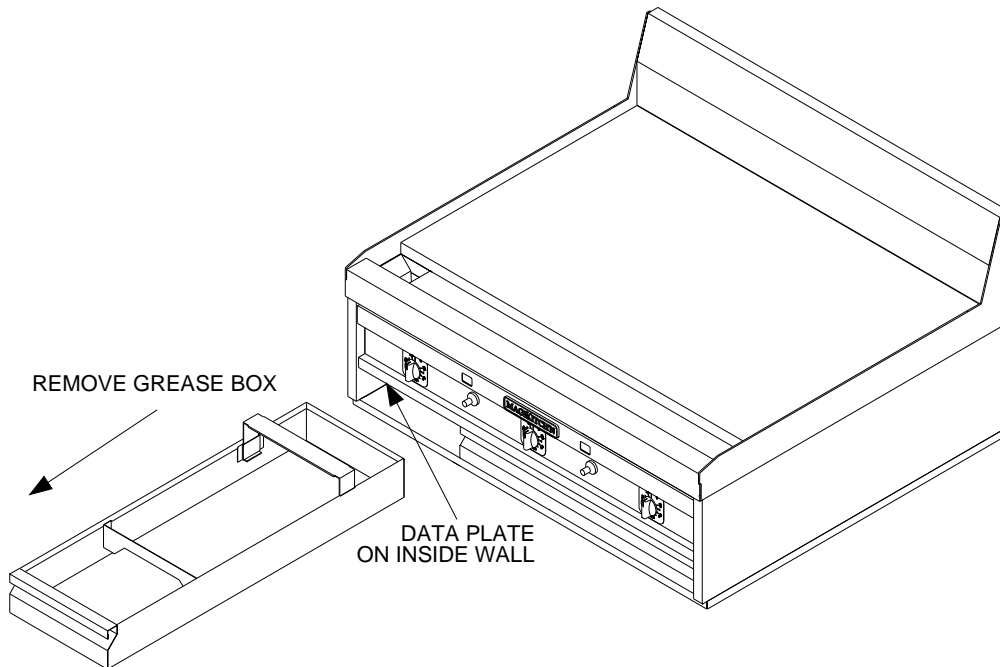

### 1.2. Installation Clearances

Your new MagiKitch'n Griddle needs clearance around it for proper operation. Adequate clearances allow for servicing and proper burner operation. The clearances shown below are for installation in combustible and non-combustible construction.

Ensure that all clearances stated on the Data plate and in the clearance section of this manual are strictly followed.

Location	Combustible Construction Inches (Centimeters)	Non-Combustible Construction Inches (Centimeters)
Cabinet back	8.0 (20.4)	8.0 (20.4)
Cabinet Sides	2.0 (5.0)	0.0 (0.0)

### 1.3. Gas Connection(s)

Your gas appliance will give you peak performance when the gas supply line is of sufficient size to provide the correct gas pressure. The gas line must be installed to meet the local building codes or National Fuel Gas Code ANSI Z223.1 Latest Edition. In Canada, install the appliance in accordance with CAN/CGA-B149.1 or .2 and local codes. In Australia, install the appliance in accordance with AS/NZS 5601. Gas line sizing requirements can be determined by your local gas company or, in North America, by referring to the National Fuel Gas Code, Appendix C, Table C-4 (for natural gas) and Table C-16 (for propane). The gas line needs to be large enough to supply the necessary amount of fuel to all appliances without losing pressure to any appliance.

**WARNING**

**NEVER** supply the appliance with a gas that is not indicated on the data plate. Using the incorrect gas type will cause improper operation. If you need to convert the appliance to another type of fuel, contact your dealer.

**1.3.1. Fuel Type(s)**

Each appliance is equipped to work with one type of fuel. The type of fuel with which the appliance is intended to operate is stamped on the data plate, see Figure 1.

**CAUTION**

**NEVER** use an adapter to make a smaller gas supply line fit the cooker connection. This may not allow proper gas flow for the optimum burner operation, resulting in poor cooking performance.

**1.3.2. Quick Disconnect Connection**

In North America, gas appliances equipped with casters must be installed with connectors that comply with the Standard for Connectors for Movable Gas Appliances, ANSI Z21.69.CSA 6.16 Latest Edition. This connection should include a quick disconnect device that complies with the Standard for Quick Disconnect Devices for Use With Gas Fuel Appliances ANSI Z21.41.CSA 6.9 Latest Edition. In Australia, an appliance equipped with casters and a flexible gas line must be connected to the gas supply with a quick disconnect device that complies with AS 4627 and a restraining cable. The restraining cable must not exceed 80% of the length of the flexible gas line. The restraining device should be attached to the appliance at the back panel.

**1.3.3. Fuel Supply Line and Leak Pressure Testing**

The fuel supply system must be tested before the appliance is used. If the fuel line is going to be tested at a pressure greater than ½ PSIG (3.45 kPA), make sure that the appliance is disconnected from fuel line. If the fuel line is to be tested at a pressure equal to or less than ½ PSIG (3.45 kPA), the appliance can be connected, but the unit's gas valve must be shut. Test all gas line connections for leaks with a solution of soap and water when pressure is applied.

**1.4. Ventilation And Fire Safety Systems**

Your new gas appliance must have proper ventilation to function safely and properly. Exhaust gas temperatures can reach as high as 1000°F (538 °C). Therefore, it is very important to install a fire safety system. Your ventilation system should be designed to allow for easy cleaning. Frequent cleaning of the ventilation system and the appliance will reduce the chances of fire. Table 1-2 provides a list of reference documents that provide guidance on ventilation and fire safety systems. This table is not necessarily complete. In North America, additional information can be obtained from CSA International, 8501 East Pleasant Valley Rd., Cleveland, OH 44131. In Australia, the ventilation system must comply with AS/NZS 5601.1.

Excessive ventilation causes drafts, which will interfere with the proper operation of the pilot and the burner. Leave at least 18 inches (47 cm) of open space between the appliance's flue vent opening and the intake of the exhaust hood.

**CAUTION**

**Ensure that your ventilation system does not cause a down draft at the appliance's flue opening. Down drafts will not allow the appliance to exhaust properly and will cause overheating which may cause permanent damage. Damage caused by down drafts will not be covered under equipment warranty. NEVER allow anything to obstruct the flow of combustibles or ventilation exiting the appliance flue. DO NOT put anything on the top of the flue area.**

**CAUTION**

**NEVER connect the blower directly to the flue opening(s). The direct flow of air will cause poor temperature recovery, poor ignition, and inefficient operation of the appliance and could extinguish the pilot(s).**

**1.5. Installation Setup**

The installation of this appliance **MUST** conform to local codes. In the absence of local codes in North America, the installation must conform with the National Fuel Gas Code, ANSI Z223.1/NFPA 54 or the Natural Gas and Propane Installation Code CSA B149.1 as applicable. In Australia, the appliance must be installed in compliance with AS/NZS 5601 (current revision).

To start, uncrate appliance and locate installation accessories shipped with the appliance.

**1.5.1. Counter Use With Legs**

**CAUTION**

To prevent equipment damage, **DO NOT** tilt your MagiKitch'n griddle on only two legs, or on its sides.

(See Figure 2) A set of 4" (10.2 cm) legs is shipped with the appliance (unless appliance was specifically ordered without legs). A threaded receptacle is located near each corner of the underside of the base of the appliance, on appliances 48" (122 cm) and wider there are threaded receptacles in the front and rear center of the base. Each leg has a similar mating thread. Raise appliance sufficiently to allow legs to be screwed tightly into receptacles. The appliance can be leveled by adjusting the feet at the bottom of the leg assembly. This can be done by turning the foot in or out to lower or raise each corner as needed.

**NOTICE**

4" Legs should not be used with the optional Equipment Stand.

**1.5.2. Counter Use Without Legs**

(See Figure 3) The appliance must be sealed to the counter to comply with applicable sanitation standards. A bead of silicone sealant, approximately ½ inch (13 mm) wide, is to be applied to the bottom of the unit approximately ¼" (7 mm) in from the front, back and side edges. We suggest Dow Corning®, GE® or Permatex® silicone 'RTV' adhesive sealant or equivalent. (See NSF Basic Criteria C-2 for details).

**1.5.3. For Use On Optional Equipment Stand**

**ATTENTION**

Rear mounting brackets should be installed to the Equipment Stand prior to placing griddle on the stand.

**CAUTION**

Only two of the four supplied casters are equipped with a locking feature. Install the griddle so that the two locking casters are at the **front of the unit**. The casters should be **LOCKED** before the unit is placed into operation.

(See Figure 4). To mount the griddle to the stand, locate joining kit supplied with stand. The joining kit should include (2) rear mounting brackets, and (4) 1/2" (13 mm) mounting bolts. To mount the griddle to the equipment, perform the steps on the following page:

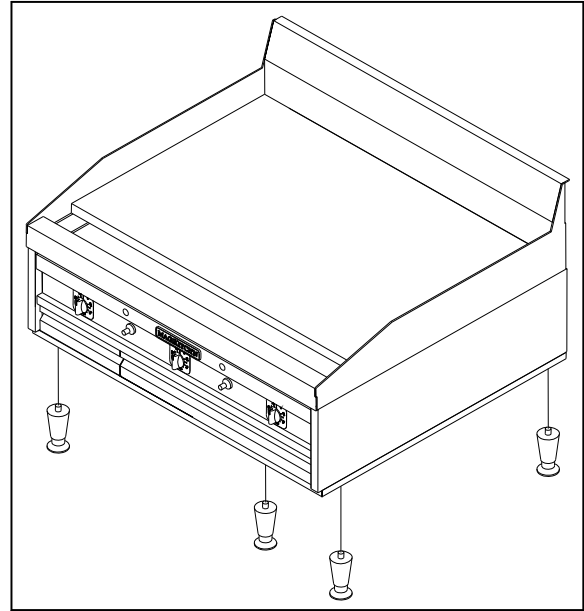

**Figure 2**

**CAUTION**

The appliance must be level to perform properly. Failure to level unit may result in improper combustion and performance of the appliance.

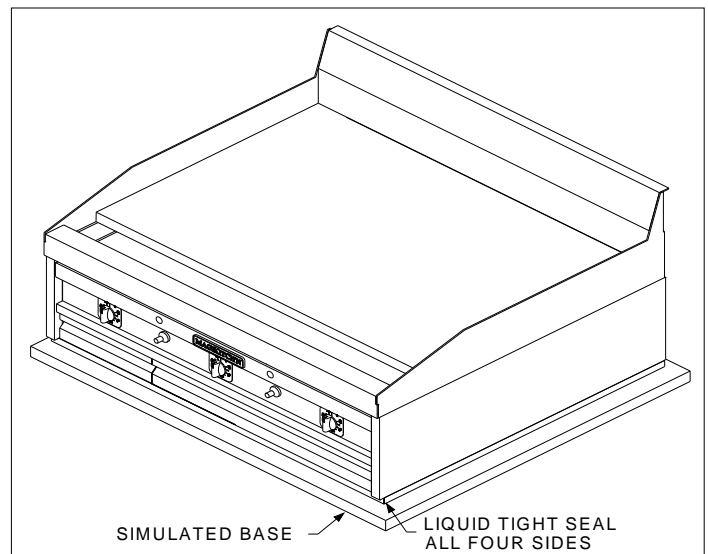
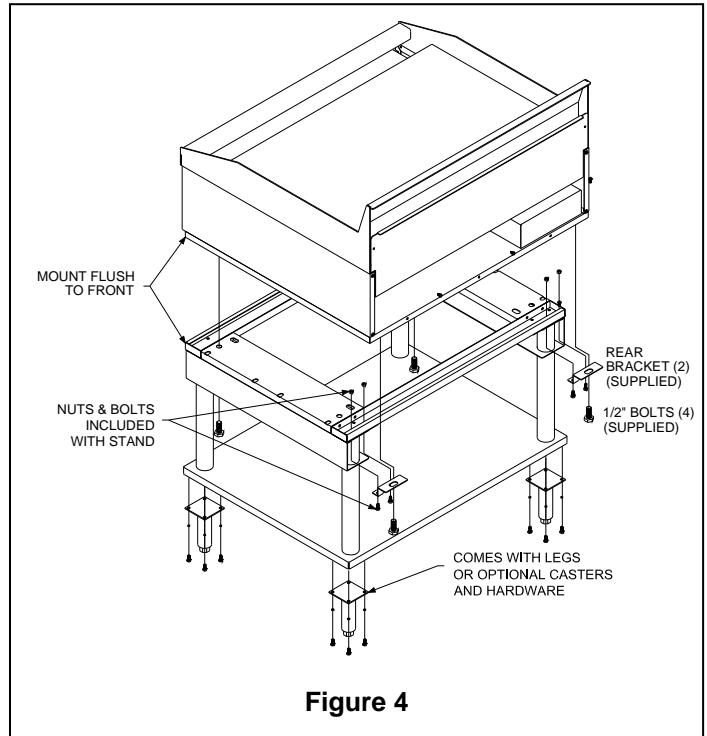

**Figure 3**

**NOTICE**

The larger units have 6 threaded receiving holes, but require only the four 1/2" (13 mm) bolts on each corner to mount the griddle.

1. Remove (4) existing 1/4-20 nuts and bolts from the rear corners of the equipment stand.
2. Align the 2 bolt holes on the rear corners of the stand with the 2 bolt holes on the rear mounting brackets. Orient the brackets as shown in Figure #4 on this page.
3. Install the provided rear mounting brackets (2) to the rear corners by using the existing 1/4-20 hardware that were removed in step 1, tighten securely.
4. Carefully place the griddle on the equipment stand.
5. Once the griddle is on the stand, position the griddle on the stand so that the front edge of the base is flush with the front of the equipment stand. If the griddle is the only appliance to be mounted on the stand, then both sides of the griddle should be flush with the sides of the equipment stand.
6. When positioned properly, the threaded receiving holes in the griddle base should be aligned with mating clearance holes at the front of the equipment stand, and with the clearance holes in the rear mounting brackets. Install the provided 1/2" (13 mm) bolts and tighten securely.



**Figure 4**

**1.5.4. Leveling Instructions**

**NOTICE**

Equipment stands are shipped from the factory with the legs or casters set to “Zero”. Units should be leveled at time of installation; failure to do so could cause the griddle to operate improperly.

1. Identify the end or corner of the stand that needs to be raised, remove the weight load from the caster or leg to be leveled.
2. **Legs-** using a wrench, or pliers turn the leg bullet, See Figure 5, CCW to raise the height of the equipment stand. There is 1/2" (13 mm) to 3/4" (19 mm) of adjustment.  
**Casters-** (For Stands shipped after May 2006) Using a Flat Head screwdriver, loosen the set screws of the caster to be leveled, See Figure 5. Turn the collar of the caster CCW to raise the height of the equipment stand. There is 1/2" (13 mm) to 3/4" (19 mm) of adjustment. After leveling adjustment is complete, re-tighten set screws.
3. Repeat Step 2 for legs or casters that require leveling.
4. Check the levelness of the equipment, if necessary Repeat steps 1, 2, and 3.

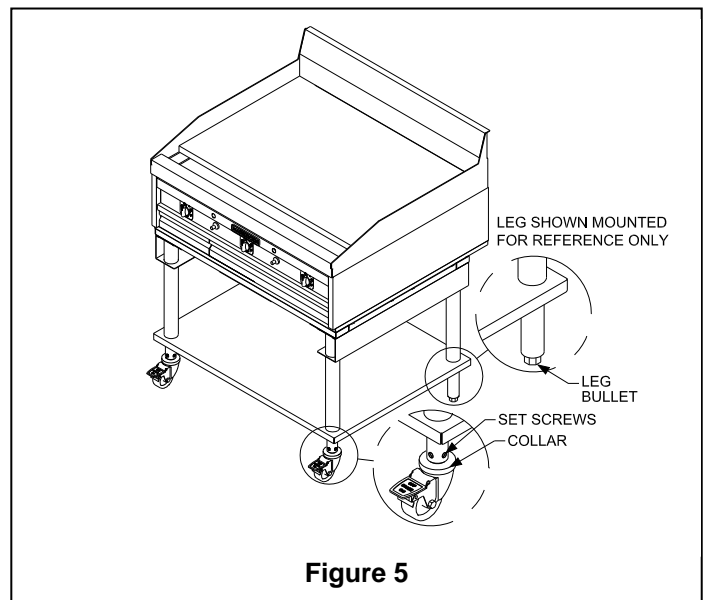

**Figure 5**

**NOTICE**

This appliance may only be installed with casters provided by the manufacturer. When installed with casters in North America, a gas connection complying with ANSI Z21.69/CGA-6.16 and a quick disconnect device complying with ANSI Z21.41/CAN 1-6.9. It must also be installed with a restraining device to guard against putting any strain on the gas connections when the unit is moved. In Australia the quick disconnect device must comply with AS4627. The restraining device must not exceed 80% of the length of the flexible gas line.

# Installation



## MKG Series Gas Griddle

### 1.6. Final Gas Connection

A properly installed gas supply system will deliver adequate pressure, between 7 and 8 inches w.c. (1.75-2.0 kPa) for natural gas, or 11 to 12 inches w.c. (2.7-3.0 kPa) for propane to all appliances connected to the line, operating at full demand.

#### 1.6.1. Regulator Assembly

An adequate gas supply is important for the appliance to operate properly. Undersized lines or low-pressures will restrict the volume of gas required for satisfactory performance. A steady supply pressure between 7" and 8" w.c. (1.75-2.0 kPa) for natural gas or 11" to 12" (2.7-3.0 kPa) for propane gas is required. With all gas appliances operating simultaneously, the manifold pressure on all gas appliances should not show any appreciable drop. Fluctuations of more than 25% on natural and 10% on propane gas will create pilot problems and affect burner operating characteristics. Contact your gas company for correct supply line sizes. After connection, a certified gas service agent should check all newly installed equipment for correct gas pressure. The unit should be connected ONLY to the type of gas for which it is equipped. Check the gas type on the Data plate; see section 1.1 of this manual.

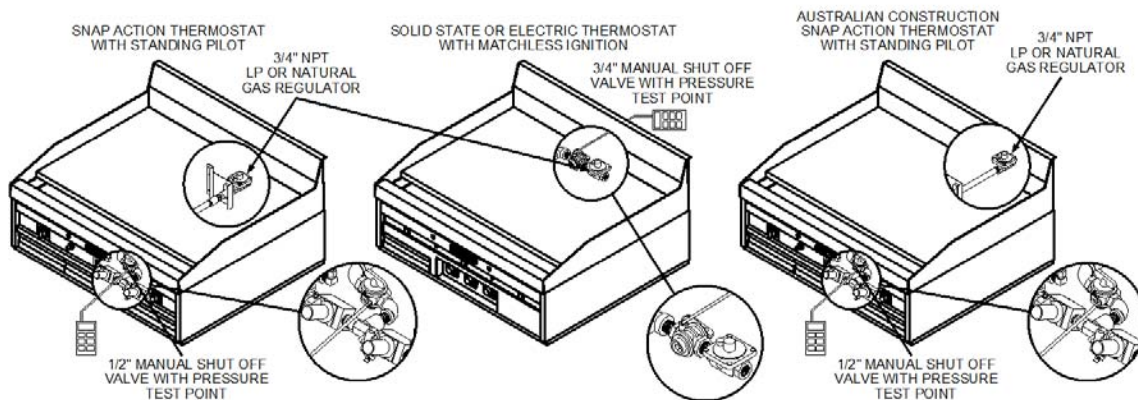

**Figure 6**

1. In most cases the gas input regulator for your new appliance has been installed at the factory, See Figure 6 for the location of the regulator and manual shut off valve on your appliance type. Note: For Australian models the regulator is supplied as a separate item. This will allow the installer to choose their method of installation in accordance with AS/NZS 5601. The example in Figure 6 shows one possible method of attachment. Using a regulator other than the one supplied with the unit will void the warranty.
2. The manifold pressure must be maintained at the pressure marked on the Data plate with all burners in operation. For appliances equipped with Solid State or Electric Thermostat controls the pressure reading is taken at the pressure test point supplied on the 3/4" (19 mm) manual shut off valve, see Figure 6. For all other griddles, a pressure test point is supplied on the 1/2" (13 mm) manual shut off valve located behind the door, also see Figure 6.
3. Use pipe joint compound that is suitable for use with LP gas on all threaded connections.
4. Turn off all thermostats.
5. Turn on gas supply and check all connections for leaks using ONLY a leak checking fluid or soapy water. NEVER use an open flame to check for gas leaks.
6. Provision must be made for adequate air supply for both the appliance and room occupants.
7. Keep area in front of unit free from obstructions that could block flow of combustion and/or ventilation air.

#### 1.6.2. Gas Settings

Orifices are sized to provide proper gas flow to the rated input power for each model. Regulator pressure must be measured and adjusted before the unit goes into service, following installation and when operational performance is in question. The manifold pressure readings are taken at the pressure test points on the supplied manual shut off valves, see Figure 6.

Gas Type	BTU/hr (kW) (MJ/h) per Burner	Manifold Pressure (All Models)
Natural	15,000 (4.4) (15.8)	4.0" WC (10 mbar) (1.0 kPa)
Propane	15,000 (4.4) (15.8)	10.0" WC (25 mbar) (2.5 kPa)



## 2. Operation Section

Ensure that a proper installation has been performed on the appliance and that all warnings, cautions, and notices contained in this manual have been read, understood and adhered to before proceeding.

### 2.1. Lighting Instructions

#### 2.1.1. Snap-Action Thermostat Appliances

1. Turn all thermostat knobs to the "OFF" position.
2. Open front door of the griddle, turn the manual gas shut off valve to the "ON" position, see Figure 6.
3. Press and hold the left or right **RED** pilot button, see detail Method A at right, and light the left or right pilot by depressing the Piezo ignition control, look through the pilot hole to see the pilot ignites. With pilot burning, keep the **RED** pilot knob depressed for 45 seconds or until pilot remains lit automatically. If the Piezo ignition control does not light the pilot(s), a flame source can be used to light the pilot(s) through the pilot holes provided in the front panel of the appliance.
4. Repeat steps 1,2, and 3 for all remaining pilots.
5. Operate thermostats by turning knobs clockwise to the desired temperature and insure that burners light properly by looking through the pilot holes provided in the front panel.

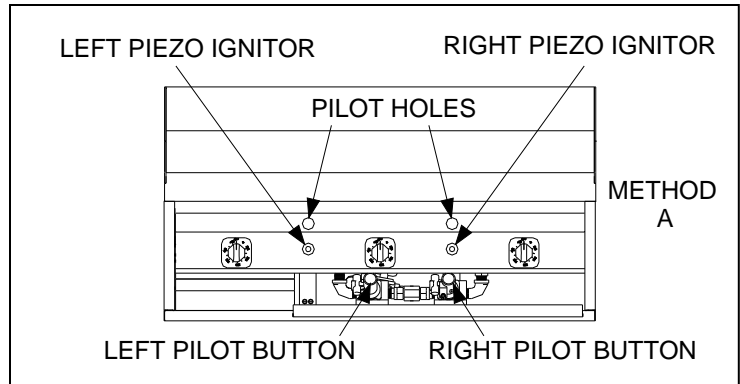

#### 2.1.2. Solid State And Electric Thermostat Appliances

1. Turn all thermostat knobs to the "OFF" position, or the lowest possible temperature setting.
2. Turn the Manual gas shut off valve to the "ON" position, this valve is located at the rear of the unit, see Figure 6.
3. Turn the **RED "I/O"** switch to the " I " (ON) position for all desired Thermostats to be operated, See detail Method B at right. When the Pilot ready (Amber) light illuminates, the pilot(s) are ready to operate the main burners.
4. Repeat steps 1,2, and 3 for all thermostat controls to be operated.
5. Operate thermostats by turning knobs clockwise to the desired temperature and insure that burners light properly by looking through the pilot holes provided in the front panel. The **RED "I/O"** switch will illuminate when the thermostat calls for heat.

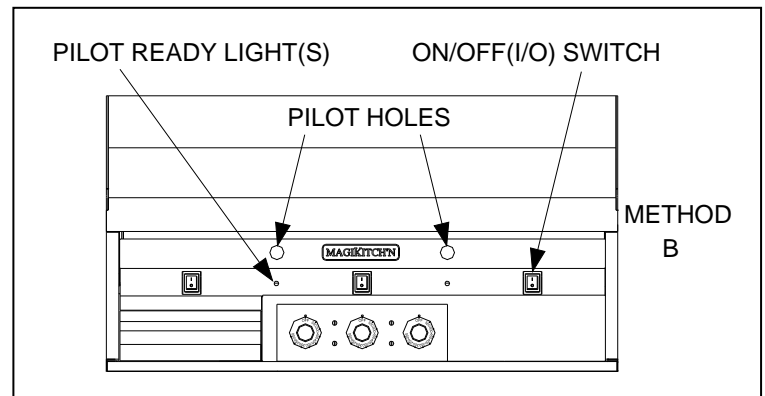

#### CAUTION

**If Pilot Ready light(s) does not illuminate, Turn all Thermostat "I/O" switches for that pilot to "O"(OFF), wait five minutes before attempting to re-light.**

**If Pilot(s) extinguish or gas supply is interrupted, turn thermostat knobs and the gas shut off valve to the "OFF" position and wait 5 minutes before attempting to re-light.**

## 2.2. Initial Startup

### NOTICE

**New griddles should be carefully tempered and cared for in order to avoid possible damage. To break in a new griddle, do the following:**

Wipe the griddle surface clean. A mild soapy water solution may be used to clean the surface, if this solution is used be sure to rinse thoroughly with fresh water to eliminate any soap residue. Also it is important to wipe the griddle surface and surrounding areas to dry up any standing water. Never allow water on a hot griddle surface.

Seasoning is not required on a Chrome Plated Cooking surface, but the following procedure may be performed to improve the non-stick qualities of the chrome plated cooking surface.

### 2.2.1. Griddle Surface Seasoning

1. To season the griddle, light all the griddle burners and set the thermostats to 200°F (93°C). As the unit heats up to 200°F (93°C), apply a light film of cooking oil or beef suet over the entire cooking surface, wiping off any excess build up. This step may be repeated as necessary to apply an even coating on the griddle surface. Seasoning will help create and maintain a non-stick surface on your griddle.
2. Allow the seasoned surface to idle for one hour at 200°F (93°), Then set the thermostats to your desired cooking temperature, once your griddle surface has reached temperature apply another coating of seasoning oil, wiping off any excess that may cause build up.

### 2.2.2. Surface Temperature Check

1. If available, place grill surface thermometer over each thermostat sensing probe 12" (30.5 cm) from the front edge of the griddle surface. The first sensing probe is located 6" (15.25 cm) from the left side of the griddle, additional sensing probes are every 12" (30.5 cm) to the right thereafter.
2. Heat the griddle up to the desired cooking temperature; check the surface temperature reading on the grill thermometer. If necessary, adjust the thermostats that control any area of the surface that are not within  $\pm 15^{\circ}\text{F}$  ( $\pm 8.3^{\circ}\text{C}$ ) of the thermostat setting. The procedure for adjusting the thermostats is in Section 3.

## 2.3. Shutdown Procedure

### 2.3.1. Snap Action Thermostat Appliances

1. Turn thermostat knobs to the "OFF" position.
2. Turn gas shut off valve to "OFF" position.
3. Allow griddle surface to cool normally.

### 2.3.2. Solid State And Electric Thermostat Appliances

1. Turn thermostat knobs to the "OFF" position, or the lowest possible temperature setting.
2. Turn "I/O" Switch to "O" position. Close manual gas valve shut off.
3. Allow griddle surface to cool normally.

### 3. Thermostat Calibration Section

Each control typically operates a pair of burners with a Snap action, Electric or Solid State. The controls were set at the factory. However, if the griddle's surface temperature varies greatly from the setting on the thermostat knob, adjust the thermostat using the following procedure:

#### 3.1. Calibration Procedures

##### 3.1.1. Snap Action And Electric Thermostat

1. Light pilots as described in section(s) 2.1.1 and 2.1.2.
2. Turn all the control knobs to the desired temperature setting.
3. Wait 30 minutes (or 1 hour if griddle was cold) for surface to stabilize.
4. Place a reliable Griddle surface thermometer, or test instrument thermocouple, able to register 300°F (149°C), in the location above the thermostat being calibrated as described in section 2.2.2. Check the temperature every 5 minutes until the temperature stabilizes and does not change by more than 30°F (16.5°C) over a 15 minute span.

5. If the average temperature over any burner set is not within +/-15°F (8.3°C) of the knob setting, adjust the corresponding thermostat. This is done by removing the knob, holding the thermostat knob stem, see picture above, (**do not allow the stem to turn or the temperature setting will not be accurate**), then turn the adjustment screw located within the center of the stem in small increments. Turn this screw counter clockwise to increase the temperature, and clockwise to decrease the temperature.

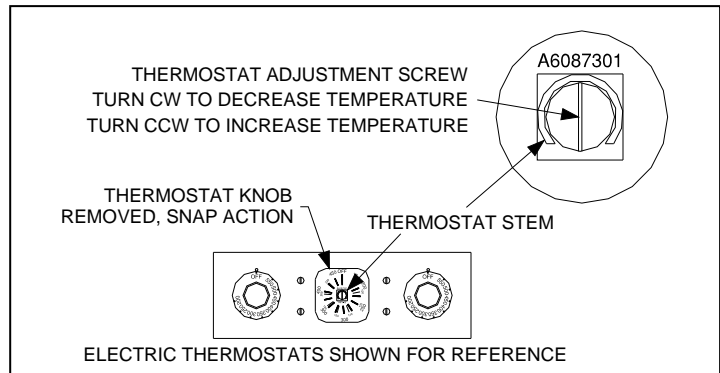

6. Check the temperature after 15 minutes and repeat adjustment as needed until the correct temperature is indication on the measuring instrument.

6. Check the temperature after 15 minutes and repeat adjustment as needed until the correct temperature is indication on the measuring instrument.

**NOTICE**

**The adjustment screw on the thermostat is sealed by the Manufacturer to protect the calibration. It may be necessary to remove this seal to be able to adjust the thermostat.**

##### 3.1.2. Solid State Thermostat

1. Light pilots as in section 2.1.2.
2. Turn all the control knobs to the desired temperature setting.
3. Wait 30 minutes (or 1 hour if griddle was cold) for surface to stabilize.
4. Place a reliable Grill surface thermometer, or test instrument thermocouple, able to register 300°F (149°C), in the location above the thermostat being calibrated described in section 2.2.2. Check the temperature every 5 minutes until the temperature stabilizes and does not change by more than 30°F (16.5°C) over a 5-minute time period. You will need to remember the average temperature for the next step.

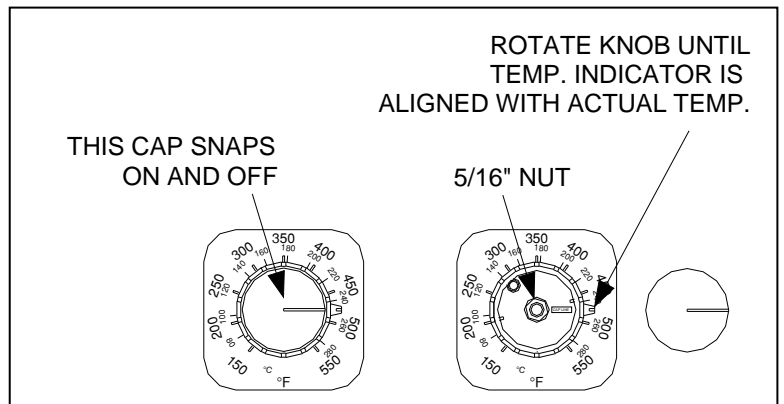

5. Carefully remove the cap on the thermostat knob with the white indicator line see picture this section. While holding the knob, loosen the 5/16" (8 mm) nut on the thermostat shaft, (**DO NOT REMOVE**), once the nut is loose the knob can be rotated so that the cap line marker is aligned with the actual temperature that the Grill surface thermometer is indicating.

6. Re-tighten the 5/16" (8mm) nut while holding the knob in position, (do not allow the stem to turn or the temperature setting will not be accurate). Replace cap.

## 4. Basic Operation

### 4.1. Operational Helpful Hints

1. Each thermostat controls 12" (30.5 cm) of griddle surface, whenever possible, use the leftmost or rightmost thermostats for the lowest cooking temperatures. The adjacent thermostats set at higher temperatures will effect centrally located thermostats.
2. For quicker thermostat response during heavy loading of the griddle, load product directly over the thermostat sensing probe. For slow periods load product to one side of the sensing probe to limit possible overheating of unused griddle surface.
3. Whenever possible, rotate the location of where product is cooked, this will keep the entire 12" (30.5 cm) of the controlled area at a more even temperature.
4. If any product sticking occurs, apply a thin coat of cooking oil to the surface before loading product.
5. When using spatulas or scrapers, it is **Highly Recommended** that the corners of the tools never strike the griddle surface with any force. This could cause damage to the surface that could collect food particles, and make it difficult to clean.

### 4.2. Suggested Cooking Times And Temperatures

#### NOTICE

The times and temperatures in this chart are suggestions only. Your experience with your own menu items will be your best guide to achieving the best food product.

<i>Product</i>	<i>Temperature°F (C°)</i>	<i>Time</i>
<b>Breakfast Items</b>		
Pancakes	375° (190°)	2 Minutes
French Toast	400° (204°)	4-5 Minutes
*Breakfast Potatoes	375°-400° (190°- 204°)	15-20 Minutes
<b>Eggs</b>		
Scrambled	300° (149°)	3-4 Minutes
Sunny Side Up	225°-300° (107° - 149°)	3-4 Minutes
Over Easy	250°-300° (121° - 149°)	2-3 Minutes
Over Hard	225°-300° (107° - 149°)	3-4 Minutes
<b>Breakfast Meats</b>		
Sausage, Link and Patty	350° (177°)	3 Minutes
Bacon	350° (177°)	2-3 Minutes
Canadian Bacon	350° (177°)	2-3 Minutes
Ham Steaks	375° (191°)	3-4 Minutes
Broiled Ham	375° (191°)	2 Minutes
Ham, Pre-Cooked	375° (191°)	2 Minutes
<b>Fish</b>		
Salmon	350° (177°)	6-8 Minutes
<b>Hamburgers</b>		
2 Patties per Lb.	350° (177°)	6-8 Minutes
4 Patties per Lb.	350° (177°)	4-6 Minutes
6 Patties per Lb.	350° (177°)	3-4 Minutes
<b>Steaks, Etc.</b>		
1/2"-3/4" Thick, Medium	375° (191°)	5-7 Minutes
3/4"-1" Thick, Medium	375° (191°)	8-10 Minutes
Beef Tenderloin	400° (204°)	3-4 Minutes
<b>Sandwiches, Etc.</b>		
Grilled Cheese	375° (191°)	3-4 Minutes
Hot Dogs	325° (163°)	2-3 Minutes

\*Based on cubed potatoes brought to a boil then cooled prior to finishing on griddle. To reduce burning and sticking of the potatoes, coat the griddle surface with vegetable oil and turn potatoes frequently.

## 5. Cleaning & Maintenance Section

### 5.1. Daily Cleaning

1. Clean the griddle surface often to prevent sticking and poor food product quality. Scrape the griddle plate regularly with a scraper intended for your type of griddle surfaces to remove all surface grease and food debris.

#### NOTICE

**Do not use Grill Bricks, Grill Screens, or any other type of abrasive material on your MagiKitch'n Chrome Griddle Surface. USING ABRASIVE MATERIALS WILL VOID YOUR WARRANTY.**

2. Clean and wipe out grease chutes.
3. Wipe down the exterior, the sides and front of the griddle are stainless steel, any stainless steel cleaner can be used to clean these surfaces.
4. Remove and empty grease box (es) of any and all debris, also wipe down the inside of the grease box compartment for food particles that may have come free from the grease box.

#### NOTICE

**The grease box is designed to contain grease run off from the griddle surface. The grease box should NEVER be allowed to overfill, and should be emptied accordingly and grease disposed of properly.**

### 5.2. Griddle Surface Cleaning, End Of Shift

#### NOTICE

**Wear protective gloves and clothing when cleaning the appliance, HOT Surfaces may cause personal injury.**

#### 5.2.1. Plain Steel Cooking Surface

1. Scrape griddle surface completely with a scraper to remove grease and food debris.
2. Use a grill brick or grill screen to clean any heavy build up of carbon from the griddle surface. Never use steel wool pads, small fibers may be left behind on the cooking surface.
3. When griddle surface is cool, Polish surface with Magi Kleans'r, or similar type non-abrasive, non-caustic cleaners that are approved for stainless steel.
4. It may be necessary to season the grill again after this cleaning.

#### 5.2.2. Chrome Plated Cooking Surface

1. Scrape griddle surface completely with supplied scraper to remove grease and food debris.

#### NOTICE

**Do not use Grill Bricks, Grill Screens, or any other type of abrasive material on your MagiKitch'n Chrome Griddle Surface. USING ABRASIVE MATERIALS WILL VOID YOUR WARRANTY.**

2. When griddle surface is cool, scrub the Chrome surface with the supplied palmetto cleaning brush and cool water.
3. Shine the Chrome griddle cooking surface with Magi Kleans'r, water and a soft cloth.
4. Rinse with clean water and wipe away any residue with a dry cloth.

### 5.3. Monthly Maintenance

#### NOTICE

**Regular maintenance of your MagiKitch'n griddle is Recommended to keep the appliance operating properly.**

#### 5.3.1. Monthly Preventative Maintenance

Food debris and grease can buildup in and around the griddle. Performing the monthly preventative maintenance steps below will keep your equipment safe and at peak performance. If you are producing high quantities of grilled foods, it may be necessary to clean these components more than once a month

- ✓ Use a grill surface thermometer to make sure thermostats are operating properly.
- ✓ Visually check that the pilot(s) flame(s) are strong and light the main burners properly.
- ✓ Visually check the appearance of the main burners, all burners should have a nice blue flame.
- ✓ Make sure that all gas connections have not been tampered with or damaged, check for leaks with a soapy water solution. **Never use an open flame to check for leaks.**
- ✓ Check to see that the flue exhaust area has no food debris, or blocked in any way. Never allow the flue to become excessively dirty. The flue being free of obstruction is imperative to proper burner operation.

# Cleaning & Maintenance



## MKG Series Gas Griddle

- ✓ Check to see that the ventilation hood and make up air systems are working properly. Any make up air system should not be directed as to impede the flow of combustion air to the griddle, or flue exhaust from the griddle.
- ✓ Inspect griddle surface for any visible damage.

### 5.4. Annual/Periodic Preventative Maintenance and Inspection

Tasks in this section should ONLY be performed by a qualified service technician as part of a regular kitchen maintenance program. This inspection should take place a minimum of once a year by an Authorized Service Technician recommended by MagiKitch'n. It may be necessary perform this inspection more then once a year.

#### 5.4.1. Safety Evaluation

- ✓ Check all gas connections, and verify that the griddle retention/lanyard system is in place.
- ✓ Check for food debris and grease migration in and around the cabinet of the appliance.
- ✓ Check legs/casters, and ensure all nuts and bolts are secured. (If Equipped)
- ✓ Check the power cord and plug. (Matchless ignition units only)
- ✓ Check all exposed wiring connections, switches and indicator lights. (Matchless ignition units only)

#### 5.4.2. Mechanical Inspection

- ✓ Check griddle surface for damage, rust, and any cracks in the chrome plating if applicable.
- ✓ Check grease box for leaks.
- ✓ Check for grease and water migration, clean as necessary.
- ✓ Check ventilation hood drain cup and filters, clean as necessary.
- ✓ Check flue for foreign debris and hood down draft currents.
- ✓ Check for loose parts.
- ✓ Check for missing parts and fasteners, replace as necessary.

#### 5.4.3. Systems Operation Inspection

- ✓ Check incoming gas pressure when all gas appliances are operating.
- ✓ Check burner manifold gas pressure, adjust as necessary to Data plate information.
- ✓ Check Ignition system and pilot flame, clean and adjust as necessary.
- ✓ Matchless ignition units inspect spark gap, and spark electrode for damage.
- ✓ Piezo units check thermopile for damage.
- ✓ Check and clean vent opening on manual shut off valve.
- ✓ Check main gas valves for mechanical and electrical functionality.
- ✓ Check all wire terminations, check for broken, or frayed wires.
- ✓ Check temperature calibration.
- ✓ Check thermostat operation and features for proper operation.
- ✓ Verify all components are in good physical condition.
- ✓ Ensure that all components are clean, and do not have any grease or water damage.

### 5.5. Ventilation Hood

Proper ventilation hood operation is very important for the correct operation of this appliance and the safety of personnel. The ventilation hood should be inspected at the time of installation of this appliance to insure that it will operate properly in conjunction with the appliance. A regular schedule of examination, in accordance with ANSI/NFPA 96 latest edition and/or local codes must be followed.

### 5.6. Trouble Shooting Charts

The following charts may help to eliminate any basic operational problems that you may be experiencing with your appliance. Locate the problem on the left side of the chart, and cross-reference with the possible cause. Once the problem has been identified take the appropriate action to rectify the problem.

#### 5.6.1. Cooking Performance

If you are having poor cooking performance or any inconsistencies in product quality, please refer to the following chart for help.

		Possible Cause							
		Heat Set Too High	Moisture In Food Turning To Steam	Griddle Surface Dirty Or Un-Seasoned	Cooking Times Too Short	Product Shelf Life Expired	Improperly Stored Product	Excessive Oil Or Grease On Griddle Surface	Heat Set Too Low
P r o b l e m	Excessive Smoke From Fat	X	X						
	Product Sticking	X		X	X				
	Product Edges Burning	X		X	X				
	Product Centers Underdone	X				X			
	Greasy Or Un-desirable Flavor						X	X	X
	Grease Build Up On Griddle Surface	X		X				X	

#### 5.6.2. Operating Performance

The following chart may help to diagnose any operational issue you may be experiencing with your appliance. Some issues may **REQUIRE** that a qualified service technician perform the repairs. If a qualified service technician is required, please contact the factory service department (1-800-647-4826).

		Possible Cause							
		Manual Gas Valve Or Gas Supply Turned Off/ Disconnected	Unit Not Plugged In (Matchless Units Only)	Faulty Piezo Ignitor/ Thermopile/ Or Wiring	Power Switch(s) Off (Matchless Units Only)	Thermostats Turned To "Off"	Low Gas Pressure	Thermostats Not Calibrated	Thermostat Or Gas Valve Failure
P r o b l e m	Pilot(s) Will Not Light	X	X	X			X		
	Pilot Ready Light Will Not Illuminate	X	X	X	X		X		
	Power Switch Will Not Illuminate	X			X	X		X	X
	Griddle Will Not Heat Up				X	X			X
	Inconsistent Surface Temperatures						X	X	X
	Griddle Stays Hot Or Overheats							X	X

### NOTICE

**All parts and service for your MagiKitch'n griddle should be ordered and installed by a MagiKitch'n Authorized Service and Parts (ASAP) dealer. Failure to do so might result in the warranty being voided.**

## 6. Accessories

### 6.1. Standard

All plain steel and chrome plated griddles are shipped with a set of 4" (10.2 cm) adjustable legs. The appliance also comes equipped from the factory with a manual gas shutoff valve, and the specified gas regulator for the model and gas type purchased.

Each MKG Chrome surfaced griddle is equipped with a Chrome Kit which includes a cleaning brush, cleaning powder, spatula, scraper, and scraper blade replacements. See the table below for Re-Order Part Nos.

<b>Chrome Griddle</b>	<b>Accessories</b>
Magi Kleans'r	Part No. 9825-1525101
Palmetto Brush	Part No. 9825-1524901
Spatula, (Chrome Surface)	Part No. 9825-1525001
Scraper, (W/ Blade and Cover)	Part No. 9825-1528001
Replacement Blades	Part No. 9825-1528002

***Using MagiKitch'n chrome griddle accessories are important to maintaining the life of the griddle's chrome surface***

### 6.2. Optional

To order accessories for your griddle, call your local MagiKitch'n dealer for prices and availability. The list of available accessories for your new appliance will give you the flexibility to customize your griddle to the best fit for your operational requirements.

This section will show you a variety of front and rear work shelves, cutting boards, equipment stands, and other accessories to provide you with an efficient working appliance.

#### 6.2.1. Service Shelves, Front

<b>Shelf Model</b>	<b>MKG24</b>	<b>MKG36</b>	<b>MKG48</b>	<b>MKG60</b>	<b>MKG72</b>
8" Service Shelf, W/O Towel Bar	5125-1511601-C	5125-1511602-C	5125-1511603-C	5125-1511610-C	5125-1511611-C
*10" Service Shelf, W/O Towel Bar	5125-1511604-C	5125-1511605-C	5125-1511606-C	5125-1511612-C	5125-1511613-C
*12" Service Shelf, W/O Towel Bar	5125-1511607-C	5125-1511608-C	5125-1511609-C	5125-1511614-C	5125-1511615-C
8" Service Shelf, W/ Towel Bar	5125-1511701-C	5125-1511702-C	5125-1511703-C	5125-1511710-C	5125-1511711-C
*10" Service Shelf, W/ Towel Bar	5125-1511704-C	5125-1511705-C	5125-1511706-C	5125-1511712-C	5125-1511713-C
*12" Service Shelf, W/ Towel Bar	5125-1511707-C	5125-1511708-C	5125-1511709-C	5125-1511714-C	5125-1511715-C
Towel Bar Only	5125-1511801-C	5125-1511802-C	5125-1511803-C	5125-151804-C	5125-1511805-C

**\* 10" and 12" service shelves are also available with pan cutouts. Consult factory for sizes and availability.**



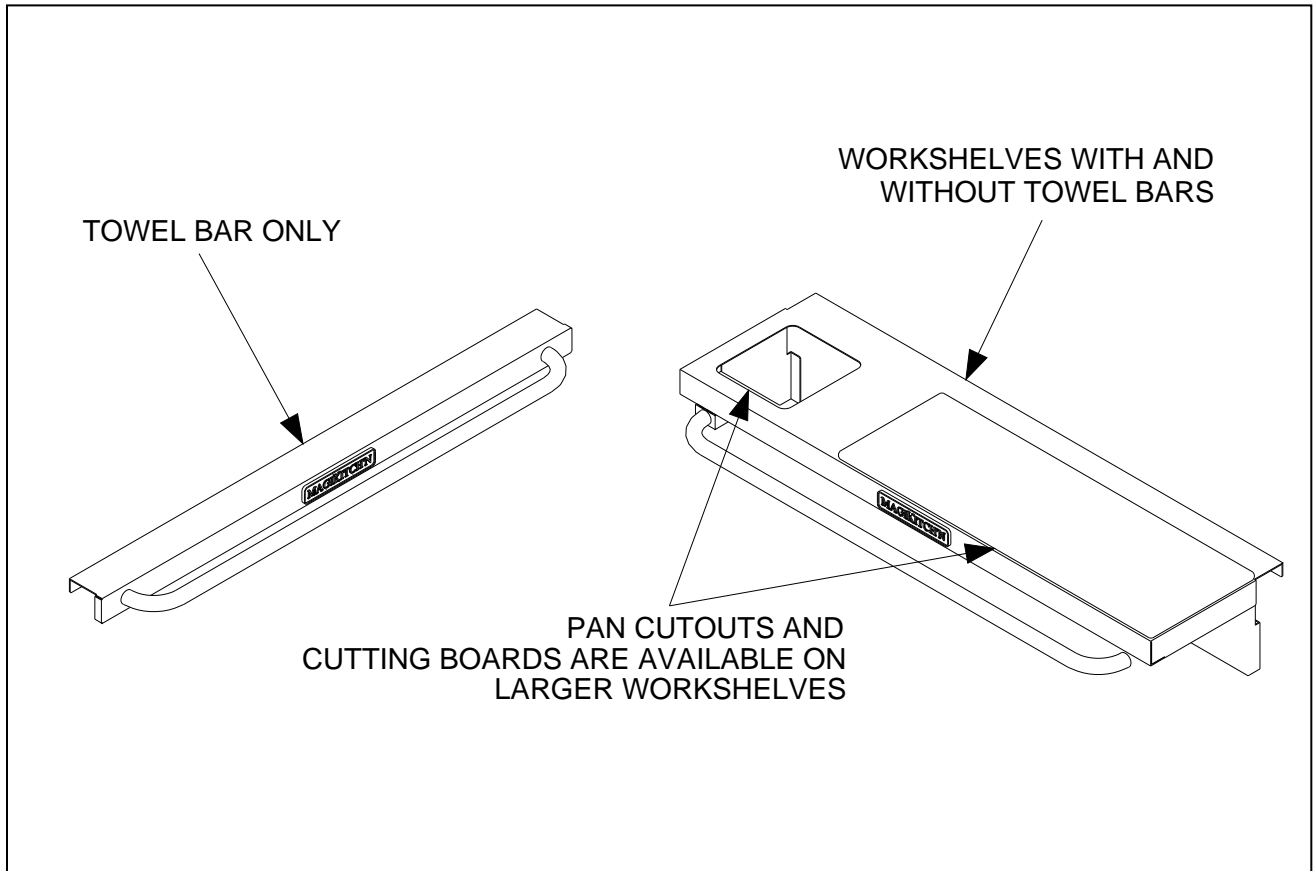

**6.2.2. Cutting Boards**

Size	Part No.
8" X 12" Cutting Board	1604-0643600-C
8" X 24" Cutting Board	1604-0643700-C
8" X 48" Cutting Board	1604-0643800-C
8" X 72" Cutting Board	1604-0643900-C

*Other sizes are available, consult factory for size, price, and availability.*

**6.2.3. Warming Shelves, Rear**

Shelf Model	Part No.
C/A, Shelf Rear MKG24	5225-1535701-C
C/A, Shelf Rear MKG36	5225-1535702-C
C/A, Shelf Rear MKG48	5225-1535703-C
C/A, Shelf Rear MKG60	5225-1535704-C
C/A, Shelf Rear MKG72	5225-1535705-C

**Shelf Kits can be attached to existing models. The Stainless Steel shelf is removable from the shelf framework for easier cleaning if necessary.**

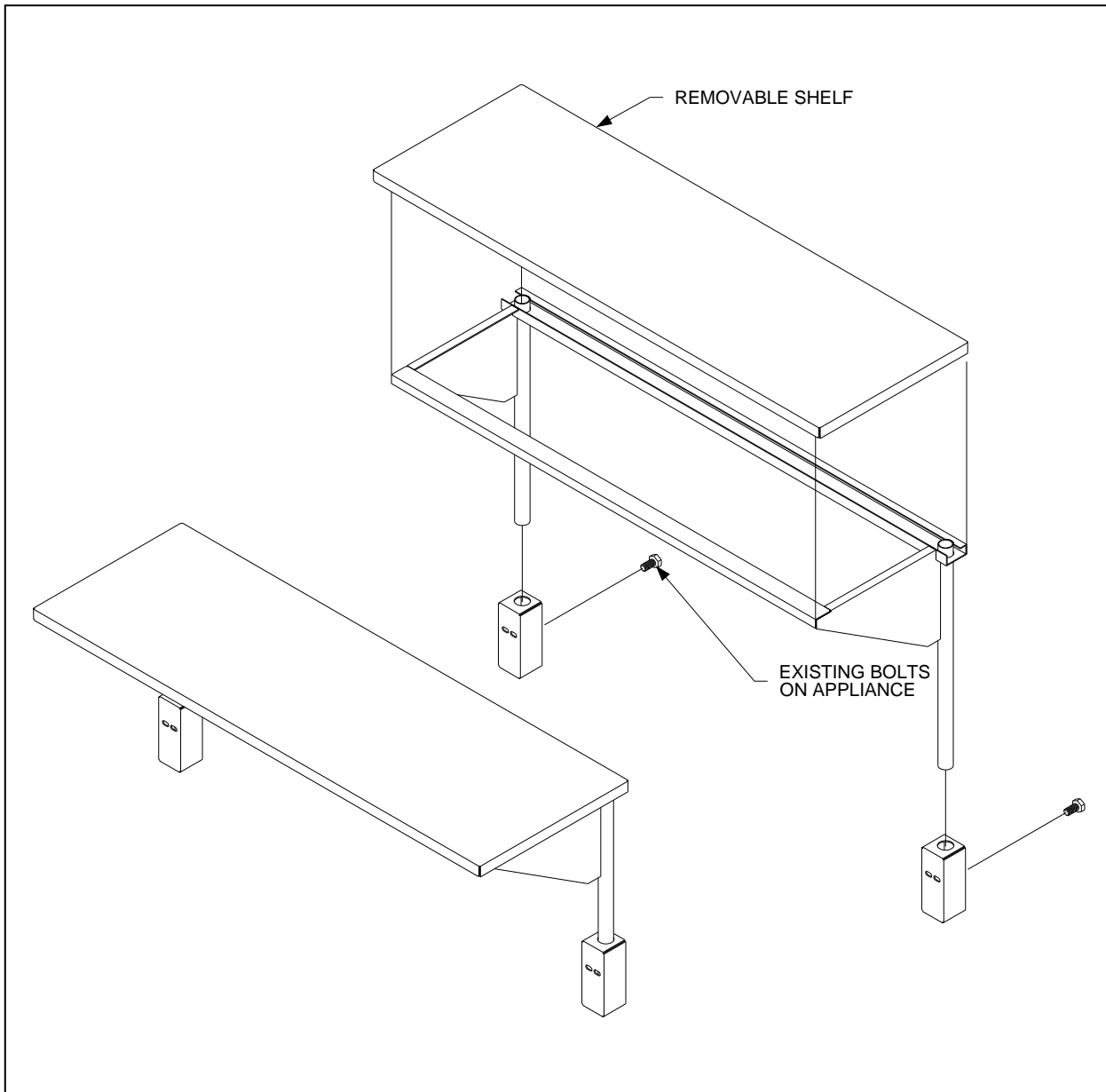

**6.2.4. Equipment Stands**

Equipment stands can be ordered with legs or casters (stands with casters shipped after May 2006 are equipped with adjustable casters).

**NOTE:**

**It should also be noted that when ordering an equipment stand for your MKG appliance, you will also need to order and MKG Joining Kit, Part No. 7225-1512101.**

Equipment Stand Model	Part No.
MKG24, W/ Legs	5225-1512001-C
MKG24, W/ Casters	5225-1512002-C
MKG36, W/ Legs	5225-1512005-C
MKG36, W/ Casters	5225-1512006-C
MKG48, W/ Legs	5225-1512007-C
MKG48, W/ Casters	5225-1512008-C
MKG60, W/ Legs	5225-1512009-C
MKG60, W/ Casters	5225-1512010-C
MKG72, W/ Legs	5225-1512011-C
MKG72, W/ Casters	5225-1512012-C

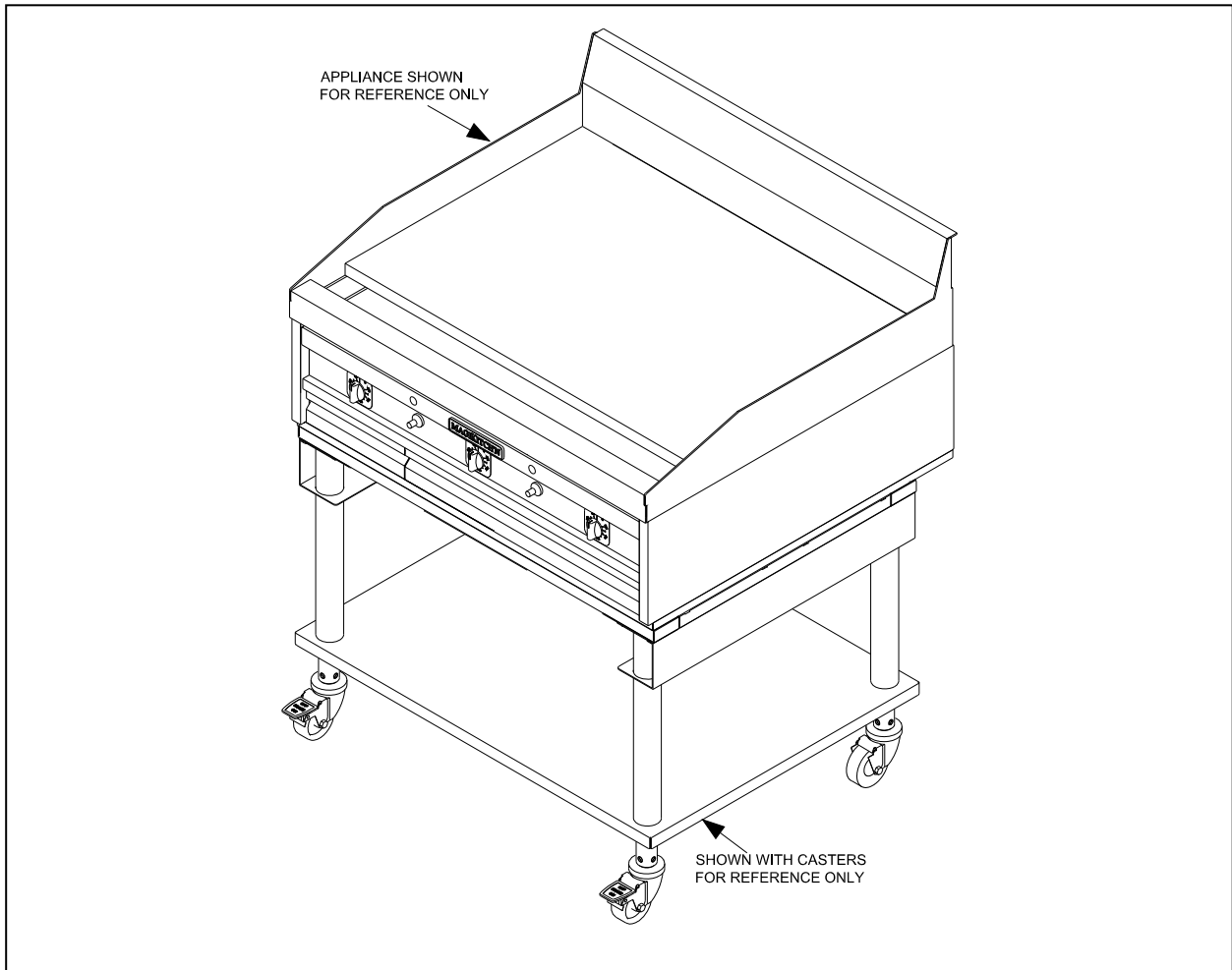

**Equipment stands may be used to hold multiple MKG Griddles. They are also compatible with MagiKitch'n Series 600 APM Charbroilers.**

**6.2.5. Miscellaneous**

Your appliance can also be used with the following miscellaneous accessories so you can customize your operation to your specific demands. The wall spacers listed below insure that you cannot push the appliance too close to the rear wall. The Utensil box gives you a handy location to store your cooking tools. The Utensil box does not interfere with any controls, and can be moved from one end of the griddle to the other without the use of tools.

Accessory	Part No.
6" Wall Spacer, LH MKG	5425-1526701-C
6" Wall Spacer, RH MKG	5425-1526702-C
Utensil Box, MKG	9825-1532501-C
Utensil Box, MKG Towel Bar Only	9825-1532502-C

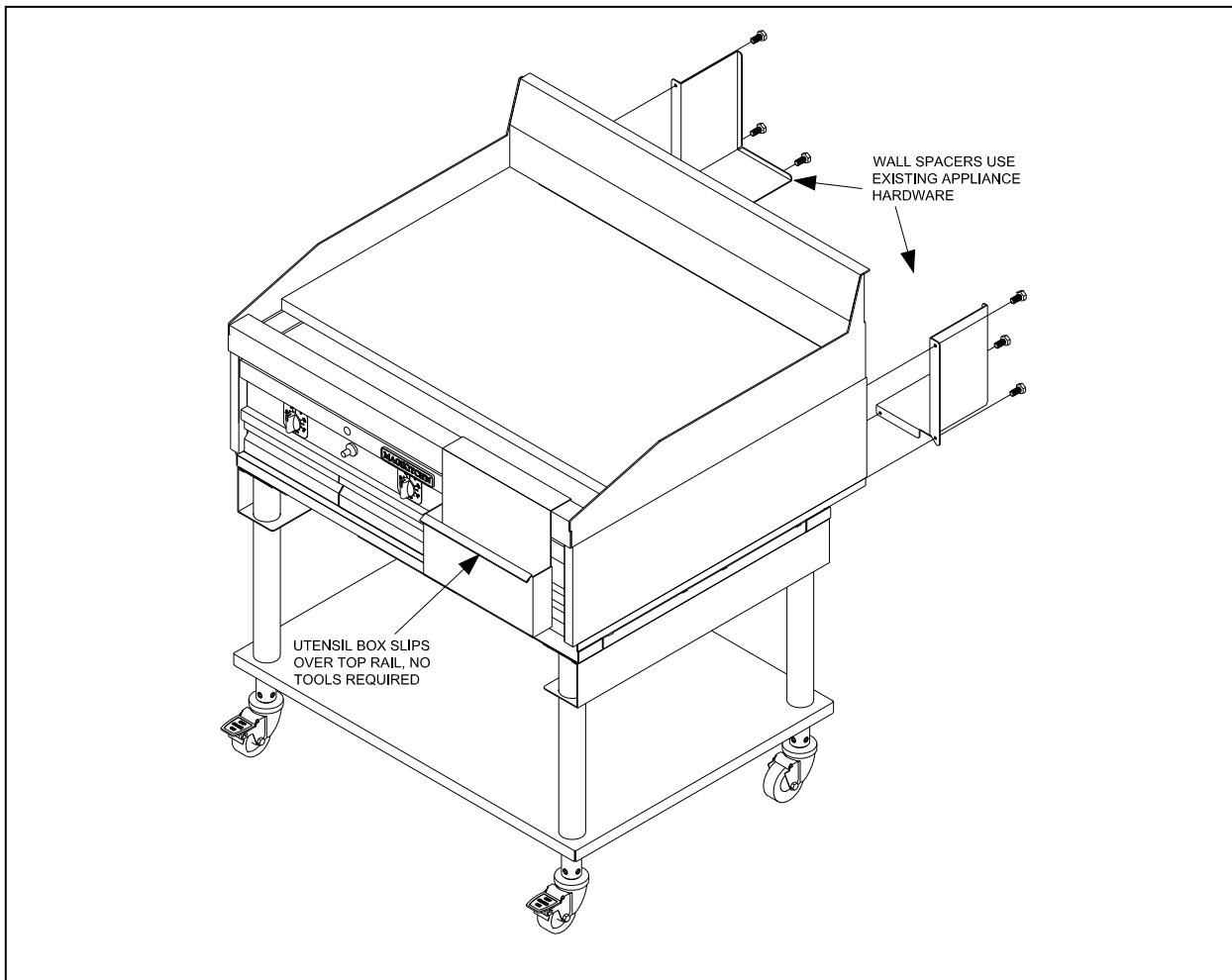

**7. Notes Page**

This Page Intentionally Left Blank

This Page Intentionally Left Blank



In the event of problems with or questions about your order, please contact the MagiKitch'n factory at  
(603) 225-6684 World Wide  
[www.magikitchn.com](http://www.magikitchn.com)

In the event of problems with or questions about your equipment, please contact the MagiKitch'n Authorized Service and Parts representative (ASAP) covering your area, or contact Pitco at the numbers listed to the left.

MAILING ADDRESS – P.O. BOX 501, CONCORD, NH 03302-0501  
SHIPPING ADDRESS – 10 FERRY ST., CONCORD, NH 03301