



MAXX ICE

ICONIC BRANDS, LEADING INNOVATION

- Ice Machines
- Ice Storage Bins
- Compact Refrigeration
- Wine Coolers
- Beverage Centers



MIPB
011824



www.maxx-ice.com | 954.202.7419

@LegacyFoodservice



Maxx Ice quality constructed ice machines are designed for simplicity and engineered with advanced technology for optimum performance.

Maxx Ice modular and self-contained ice machines are ideal for foodservice, hospitality, residential, office or retail, convenience store, entertainment, healthcare, and beverage service applications. Our product line offers models producing ice ranging from 15 lbs. up to 1000 lbs. of ice per day. In addition, Maxx Ice offers storage bins, compact refrigeration, dispensers, wine coolers and beverage centers, as well as water filtration.



@LegacyFoodservice

www.maxx-ice.com

SUPPORT

Maxx Ice Customer Support

3355 Enterprise Avenue, Suite 160
Fort Lauderdale, FL 33331
Tel: 954.202.7419
Fax: 954.202.7337
Office Hours: Monday - Friday 8:30am to 5:30pm EST

Send orders to: Orders@TheLegacyCompanies.com

Technical Support (MaxxHelp):

TechnicalServices@TheLegacyCompanies.com

Parts:

Email: CustomerService@Partstown.com
Phone: (800) 438.8898
Web: www.partstown.com/maxx_ice/parts
Hours Available (EST) Monday - Friday 7:00am to 7:00pm

WARRANTY

Maxx Ice Warranty (USA/CANADA)

Contact Maxx Ice for warranty statement at: TechnicalServices@TheLegacyCompanies.com or 877.368.2797



TABLE OF CONTENTS



ICE USAGE APPLICATION	3
CHOOSE YOUR ICE TYPE.....	4
SELF-CONTAINED ICE MACHINES	5
MODULAR ICE MACHINES.....	8
INTELLIGENT SERIES SELF-CONTAINED ICE MACHINES	9
INTELLIGENT SERIES MODULAR ICE MACHINES.....	11
RESIDENTIAL/COMMERCIAL ICE MACHINES & DISPENSERS	12
ICE STORAGE BINS	14
BIN COMPATIBILITY.....	16
PREMIUM WATER FILTERS.....	17
VALUE WATER FILTERS	18
COMPACT REFRIGERATION	19
WINE COOLERS & BEVERAGE CENTERS	21



ICE USAGE APPLICATION

Foodservice > Ice Needs Per Day

- Restaurant 1½ to 2 lbs. per person
- Cocktail..... 3 to 5 lbs. per person/seat
- Water Glass 4 oz. per 10 oz. glass
- Salad Bar 30 lbs. per cubic foot
- Fast Food 5 oz. per 7-10 oz. drink
8 oz. per 12-16 oz. drink
12 oz. per 18-24 oz. drink

Hospitality > Ice Needs Per Day

- Guest Ice 5 lbs. per room
- Restaurant ... 1½ to 2 lbs. per person/seat
- Cocktail..... 3 to 5 lbs. per person/seat
- Catering..... 1 lb. per person

Residential/Office/Retail > Ice Needs Per Day

Refer to "How to Choose an Ice Machine"

Convenience Store > Ice Needs Per Day

- Beverage 5 to 6 oz. per 12 oz. drink
8 to 10 oz. per 20 oz. drink
12 to 16 oz. per 32 oz. drink
- Packaged Ice..... lbs. per bag
"x" bags sold per day

Entertainment > Ice Needs Per Day

- Restaurant 1½ to 2 lbs. per person
- Cocktail..... 3 to 5 lbs. per person/seat

Healthcare > Ice Needs Per Day

- Bed..... 6 lbs. per bed
- Employee 2 lbs. per person
- Cafeteria 1 lb. per person

Beverage Service > Ice Needs Per Day

- Cafeteria 1 lb. per bed
- Drinks..... 40% ice per drink;
"x" number of drinks
served on peak day



HOW TO CHOOSE AN ICE MACHINE:

- A. Choose your ice type
- B. Use the calculator to determine which ice machine works best for your business

$$\begin{array}{r}
 \text{Lbs. of ice used} \\
 \times \text{ Number of} \\
 \text{customers served} \\
 \hline
 = \text{The size of} \\
 \text{ice machine you need}
 \end{array}$$

CHOOSE YOUR ICE TYPE



Full Dice Cube - hard, full dice shape
(Undercounter Ice Machines)

- MIM50 Series
- MIM150N
- MIM200N
- MIM260N
- MIM320N
- MIM120
- MIM250

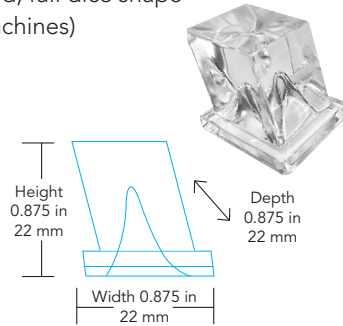

Applications:
Foodservice/Hospitality/
Entertainment/Healthcare/Beverage Service

(Modular Ice Machines)

- MIM452
- MIM600
- MIM1000
- MIM360N
- MIM370N
- MIM500N
- MIM650N
- MIM1000N

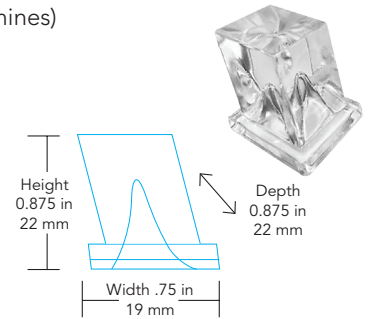

Applications:
Foodservice/Hospitality/Convenience Store/
Entertainment/Healthcare/Beverage Service



Half Dice Cube - hard, half dice shape

- MIM85H
- MIM125H
- MIM265H
- MIM150NH
- MIM200NH
- MIM260NH
- MIM320NH
- MIM360NH
- MIM370NH
- MIM500NH
- MIM650NH
- MIM1000NH

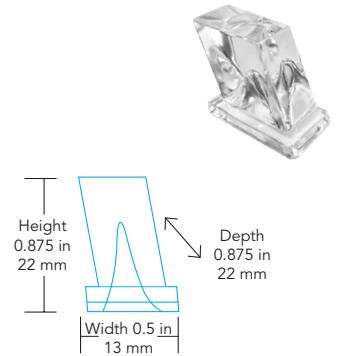

Applications:
Foodservice/Hospitality/Convenience Store/Entertainment/Healthcare/Beverage Service



Bullet Cube - large, hard, bullet shape

- MIM75
- MIM130

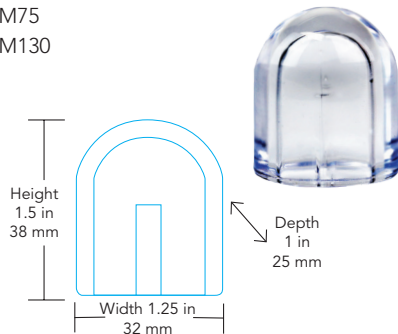

Applications:
Foodservice/Hospitality/
Entertainment/Beverage Service



Square Cube - hard, solid, square shape

- MIM100

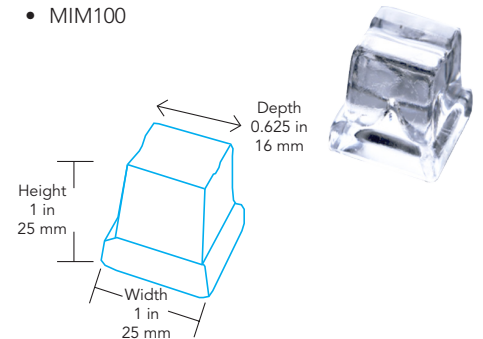

Applications:
Foodservice/Hospitality/
Entertainment/Beverage Service



Crescent Cube - hard, crescent shape

- MIMC15C
- MIM25C
- MIM25CO

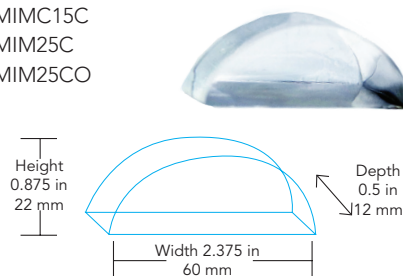

Applications:
Foodservice/Hospitality/Residential/Office/Retail



Nugget Ice Cube - chewable, soft, square shape

- MAXNG30

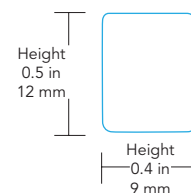

Applications:
Residential/Office/Retail



 **MAXX ICE**

SELF-CONTAINED & MODULAR ICE MACHINES

Maxx Ice units are engineered with a vertical evaporator you can depend on for reliable ice production and are constructed of durable stainless steel for foodservice applications.

SELF-CONTAINED ICE MACHINES



MIM50/MIM50P
14.6"W x 25"D x 33.3"H

Indoor/Premium Indoor Ice Machine; stainless steel door, black cabinet



MIM50V
14.6"W x 23.4"D x 33.3"H

Indoor Ice Machine; black door, black cabinet



MIM50-O
14.6"W x 25"D x 33.3"H

Indoor/Outdoor Ice Machine; stainless steel exterior



MIM50P-O
14.6"W x 25"D x 33.3"H

Premium Outdoor Ice Machine; stainless steel exterior



MIM50P-ADA
14.6"W x 24.3"D x 31.9"H

Premium Indoor Ice Machine - ADA Compliant; stainless steel door, black cabinet

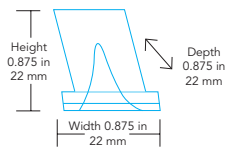

Full Dice Cube

MIM50/MIM50P/MIM50V/MIM50-O/MIM50P-O Features:

- Ideal for residential and commercial applications
- Solid state controls
- Self-cleaning mode
- Air-cooled compressor
- ENERGY STAR rated

MIM50P-ADA Features:

- 31.9" height - ideal for any freestanding or built-in ADA residential and commercial applications

MODEL #	DAILY ICE PRODUCTION (70°F AIR/50°F WATER)	AMP DRAW (MAKING/HARVESTING)	NET WEIGHT/ SHIPPING WEIGHT	REFRIGERANT AND CHARGE SIZE	ELECTRICAL
MIM50	60 lbs (27.2 kg)	3A/3.6A	84 lbs (38 kg) 93 lbs (42 kg)	R-134a 3.88 oz (110 g)	115V/60Hz/1Ph
MIM50V	50 lbs (22.7 kg)	3A/4A	84 lbs (38 kg) 93 lbs (42 kg)	R-134a 3.88 oz (110 g)	115V/60Hz/1Ph
MIM50P	65 lbs (29.5 kg)	3A/4A	92 lbs (41.7 kg) 101 lbs (45.8 kg)	R-134a 3.88 oz (110 g)	115V/60Hz/1Ph
MIM50P-O	65 lbs (29.5 kg)	3A/4A	92 lbs (41.7 kg) 101 lbs (45.8 kg)	R-134a 3.88 oz (110 g)	115V/60Hz/1Ph
MIM50-O	60 lbs (27.2 kg)	3A/4A	83 lbs (37 kg) 93 lbs (42 kg)	R-134a 3.88 oz (110 g)	115V/60Hz/1Ph
MIM50P-ADA	65 lbs (29.5 kg)	3A/4A	81 lbs (37 kg) 90 lbs (41 kg)	R-134a 3.88 oz (110 g)	115V/60Hz/1Ph





MIM75

16.7"W x 21"D x 32.7"H



MIM100/MIM130

22"W x 21"D x 32.7"H

Storage capacity:

- MIM75: 25 lbs (11 kg)
- MIM100/MIM130: 35 lbs (15.9 kg)



MIM85H

16.7"W x 21"D x 32.7"H



MIM120/MIM125H

22"W x 21"D x 32.7"H

Storage capacity:

- MIM85H: 25 lbs (11 kg)
- MIM120/MIM125H: 35 lbs (15.9 kg)



MIM250

24"W x 24"D x 38.6"H



MIM265H

24"W x 24"D x 38.6"H

Storage capacity:

- ALL MODELS: 75 lbs (34 kg)

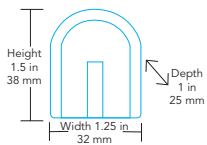

Bullet Cube

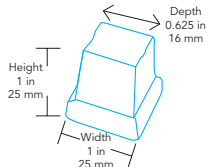

Square Cube

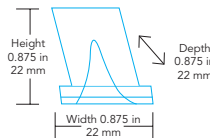

Full Dice Cube

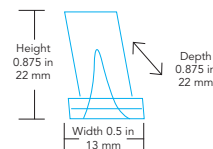

Half Dice Cube

All Models Feature:

- Exterior is constructed of stainless steel and black trim
- Front breathing design
- Air-cooled compressor
- Indoor Ice Machine; stainless steel exterior, black door & trim

MODEL #	ICE TYPE	DAILY ICE PRODUCTION (70°F AIR/50°F WATER)	AMP DRAW (NOMINAL/MAX)	NET WEIGHT/ SHIPPING WEIGHT	REFRIGERANT AND CHARGE SIZE	ELECTRICAL
MIM75	Bullet	75 lbs (34 kg)	6.7A/11.2A	93 lbs (42 kg) 104 lbs (47 kg)	R-134a 6.35 oz (180 g)	115V/60Hz/1Ph
MIM100	Square	110 lbs (50 kg)	7.3A/11.7A	106 lbs (48 kg) 125 lbs (57 kg)	R-134a 9.17oz (260 g)	115V/60Hz/1Ph
MIM130	Bullet	130 lbs (59 kg)	7.5A/11.8A	106 lbs (48 kg) 129 lbs (58.5 kg)	R-134a 9.17 oz (260 g)	115V/60Hz/1Ph
MIM120	Full Dice	120 lbs (54.4 kg)	7.5A/11.8A	110 lbs (50 kg) 129 lbs (58.5 kg)	R-134a 8.47oz (240 g)	115V/60Hz/1Ph
MIM85H	Half Dice	88 lbs (40 kg)	3.8A/4.7A	93 lbs (42 kg) 104 lbs (47 kg)	R-134a 4.66 oz (132 g)	115V/60Hz/1Ph
MIM125H	Half Dice	125 lbs (56.7 kg)	7.5A/11.8A	110 lbs (50 kg) 129 lbs (58.5 kg)	R-134a 8.47oz (240 g)	115V/60Hz/1Ph
MIM250	Full Dice	260 lbs (118 kg)	9.2A/12A	144 lbs (65 kg) 160 lbs (72.5 kg)	R-134a 22.9 oz (649 g)	115V/60Hz/1Ph
MIM265H	Half Dice	265 lbs (120 kg)	9.2A/12A	144 lbs (65 kg) 160 lbs (72.5 kg)	R-134a 22.9 oz (649 g)	115V/60Hz/1Ph

MODULAR ICE MACHINES



MIM452
30"W x 24"D x 21"H

- ENERGY STAR rated



MIM600
30"W x 24"D x 21"H



MIM1000
30"W x 24"D x 26.63"H

**Models Shown on a MIB400 storage bin - sold separately*

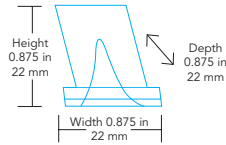

Full Dice Cube

All Models Feature:

- 30" models can be stacked with addition of an adapter
- Compatible ice storage bin sold separately
- Exterior is constructed of stainless steel
- Automatic cleaning cycle and bin overflow prevention
- Modular Ice Machine; stainless steel exterior

MODEL #	ICE TYPE	DAILY ICE PRODUCTION (70°F AIR/50°F WATER)	AMP DRAW (NOMINAL/MAX)	NET WEIGHT/ SHIPPING WEIGHT	REFRIGERANT AND CHARGE SIZE	ELECTRICAL
MIM452	Full Dice	460 lbs (209 kg)	12.4A/15.3A	130 lbs (59 kg) 148 lbs (67 kg)	R-404a 24.5 oz (659 g)	115V/60Hz/1Ph
MIM600	Full Dice	602 lbs (275 kg)	7.60A/9.85A	110 lbs (50 kg) 129 lbs (58.5 kg)	R-404a 45.8 oz (1298 g)	230V/60Hz/1Ph
MIM1000	Full Dice	1000 lbs (454 kg)	9.2A/11.3A	194 lbs (88 kg) 208 lbs (94 kg)	R-404a 57.9 oz (1641 g)	230V/60Hz/1Ph





MAXX ICE

INTELLIGENT SERIES SELF-CONTAINED & MODULAR ICE MACHINES

Experience Intelligent Series Ice Machines by Maxx Ice, innovation with you in mind. Intelligent Series Ice Machines are designed to consume up to 40% less water than similar competitor units and produce ice up to 20% faster. These are available in both self-contained and modular units producing full dice and half dice cubes.



INTELLIGENT SERIES SELF-CONTAINED ICE MACHINES



MIM150N/MIM150NH
24"W x 24"D x 39"H



MIM200N/MIM200NH
24"W x 24"D x 39"H



MIM260N/MIM260NH
24"W x 24"D x 39"H



MIM320N/MIM320NH
30"W x 28"D x 39"H

- ENERGY STAR rated

All Intelligent Series Ice Machines are designed to consume up to 40% less water than similar competitor units and produce ice up to 20% faster.

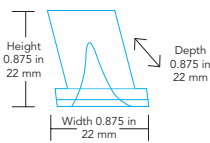

Full Dice Cube

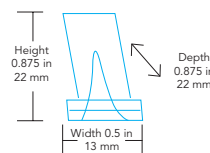

Half Dice Cube

All Models Feature:

- Storage capacity: 75 lbs (34 kg)
- Antimicrobial agent within storage bin liner for improved sanitation
- Air-cooled compressor
- Programmable, user-friendly digital controls
- Automatic cleaning cycle and bin overflow prevention
- Self-contained Ice Machine; stainless steel exterior, black trim

MODEL #	ICE TYPE	DAILY ICE PRODUCTION (70°F AIR/50°F WATER)	AMP DRAW (NOMINAL/MAX)	NET WEIGHT/ SHIPPING WEIGHT	REFRIGERANT AND CHARGE SIZE	ELECTRICAL
MIM150N	Full Dice	152 lbs (69 kg)	5.2A/6.4A	139 lbs (63 kg) 155 lbs (70.5 kg)	R-134a 7 oz (198 g)	115V/60Hz/1Ph
MIM150NH	Half Dice	152 lbs (69 kg)	5.2A/6.4A	139 lbs (63 kg) 155 lbs (70.5 kg)	R-134a 7 oz (198 g)	115V/60Hz/1Ph
MIM200N	Full Dice	199 lbs (90 kg)	7.1A/7.4A	144 lbs (65 kg) 160 lbs (72.5 kg)	R-404a 8.11 oz (230 g)	115V/60Hz/1Ph
MIM200NH	Half Dice	199 lbs (90 kg)	7.1A/7.4A	144 lbs (65 kg) 160 lbs (72.5 kg)	R-404a 8.11 oz (230 g)	115V/60Hz/1Ph
MIM260N	Full Dice	265 lbs (120 kg)	7.1A/9.8A	144 lbs (65 kg) 160 lbs (72.5 kg)	R-404a 10.6 oz (300 g)	115V/60Hz/1Ph
MIM260NH	Half Dice	265 lbs (120 kg)	7.1A/9.8A	144 lbs (65 kg) 160 lbs (72.5 kg)	R-404a 10.6 oz (300 g)	115V/60Hz/1Ph
MIM320N	Full Dice	328 lbs (148 kg)	8A/9A	148 lbs (67 kg) 164 lbs (74.4 kg)	R-404a 12.5 oz (354 g)	115V/60Hz/1Ph
MIM320NH	Half Dice	328 lbs (148 kg)	8A/9A	148 lbs (67 kg) 164 lbs (74.4 kg)	R-404a 12.5 oz (354 g)	115V/60Hz/1Ph





MIM360N*/MIM360NH*
22"W x 24.6"D x 21"H

- Ideal for drink dispensers
- ENERGY STAR rated



MIM370N*/MIM370NH*
30"W x 24.6"D x 21"H

- ENERGY STAR rated



MIM500N*/MIM500NH*
30"W x 24.6"D x 21"H

- ENERGY STAR rated



MIM650N**/MIM650NH**
30"W x 24.6"D x 21"H



MIM1000N**/MIM1000NH**
30"W x 24.6"D x 26.7"H

*Models Shown on MIB310N/470N storage bin - sold separately

**Models Shown on MIB470N storage bin - sold separately

All Intelligent Series Ice Machines are designed to consume up to 40% less water than similar competitor units and produce ice up to 20% faster.

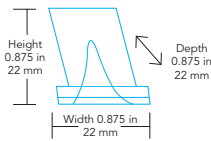

Full Dice Cube

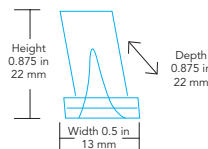

Half Dice Cube

All Models Feature:

- Can be stacked with the addition of an adapter plate
- Hinged front panel allows for easy access and service
- User friendly, exterior diagnostic digital controller display
- Compatible ice storage bins MIB310N, MIB470N or MIB580N sold separately
- Modular Ice Machine; stainless steel exterior, black trim

MODEL #	ICE TYPE	DAILY ICE PRODUCTION (70°F AIR/50°F WATER)	AMP DRAW (NOMINAL/MAX)	NET WEIGHT/ SHIPPING WEIGHT	REFRIGERANT AND CHARGE SIZE	ELECTRICAL
MIM360N	Full Dice	373 lbs (169 kg)	7.1A/9.8A	144 lbs (65 kg) 160 lbs (72.5 kg)	R-404a 10.6 oz (300 g)	115V/60Hz/1Ph
MIM360NH	Half Dice	361 lbs (120 kg)	7.1A/9.8A	144 lbs (65 kg) 160 lbs (72.5 kg)	R-404a 10.6 oz (300 g)	115V/60Hz/1Ph
MIM370N	Full Dice	373 lbs (169 kg)	7.5A/10.5A	93 lbs (42 kg) 111.5 lbs (50.5 kg)	R-404a 24.5 oz (695 g)	115V/60Hz/1Ph
MIM370NH	Half Dice	361 lbs (164 kg)	7.5A/10.5A	93 lbs (42 kg) 111.5 lbs (50.5 kg)	R-404a 24.5 oz (695 g)	115V/60Hz/1Ph
MIM500N	Full Dice	521 lbs (236 kg)	7A/9.3A	130 lbs (59 kg) 148 lbs (67 kg)	R-404a 24.5 oz (695 g)	115V/60Hz/1Ph
MIM500NH	Half Dice	513 lbs (233 kg)	7A/9.3A	130 lbs (59 kg) 148 lbs (67 kg)	R-404a 24.5 oz (695 g)	115V/60Hz/1Ph
MIM650N	Full Dice	650 lbs (295 kg)	7.1A/8A	155 lbs (70 kg) 165 lbs (75 kg)	R-404a 43 oz (1219 g)	230V/60Hz/1Ph
MIM650NH	Half Dice	645 lbs (292 kg)	7.1A/8A	155 lbs (70 kg) 165 lbs (75 kg)	R-404a 43 oz (1219 g)	230V/60Hz/1Ph
MIM1000N	Full Dice	937 lbs (425 kg)	10A/11.1A	194 lbs (88 kg) 208 lbs (94 kg)	R-404a 57.14 oz (1620 g)	230V/60Hz/1Ph
MIM1000NH	Half Dice	1005 lbs (456 kg)	10A/11.1A	194 lbs (88 kg) 208 lbs (94 kg)	R-404a 57.14 oz (1620 g)	230V/60Hz/1Ph



MAXX ICE

RESIDENTIAL/COMMERCIAL ICE MACHINES & DISPENSERS

Maxx Ice Residential/Commercial Ice Machines produce individual crescent cubes up to 25 lbs per day or nugget ice up to 33 lbs per day.

MIM25 Series are available as indoor or outdoor models with stainless steel or black exterior finishes, making them perfect for various freestanding or built-in applications, while the MIMC15C is ideal for everyday use.

The popular nugget ice dispenser produces ice customers crave in a sleek compact design making a perfect addition to any countertop.



MIM25C

14.6"W x 18.8"D x 33.6"H

MIM25CO

14.6"W x 18.8"D x 33.6"H

MIMC15C

14.8"W x 18.5"D x 24.8"H

MAXNG30

10.5"W x 16.5"D x 16.5"H

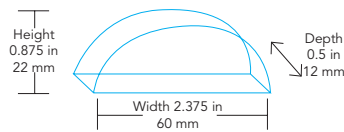

Crescent Cube

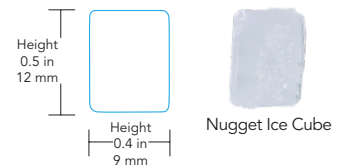

Nugget Ice Cube

MIM25C/MIMC15C - Stainless steel door, black cabinet

MIM25CO - Stainless steel cabinet and door

- Storage capacity: 22 lbs (11 kg)
- Shallow 18.8" depth allows for installation in narrow spaces and standard depth applications
- Top handle stainless steel door is field-reversible for left or right door operation
- Storage capacity: 12 lbs (5.4 kg)
- Compact design with 24.8" height allows for under counter installation and is ADA compliant
- Side handle stainless steel door is field-reversible for left or right door operation
- ADA Compliant, Stainless steel door, black cabinet
- Storage capacity: 3 lbs (1.5 kg)
- Sleek, compact design fits easily on countertops
- Equipped with an air-cooled compressor
- Easy to use electronic controls make it simple to dispense ice with the push of a button and turn ice maker on and off
- Stainless steel finish

All Models Feature:

- Automatic shut-off when bin is full
- Door-close assist feature forms strong seal when door is closed, preventing accidental opening
- Designed for free-standing or built-in applications

MODEL #	DAILY ICE PRODUCTION (70°F AIR/50°F WATER)	AMP DRAW (MAKING/HARVESTING)	NET WEIGHT/ SHIPPING WEIGHT	REFRIGERANT AND CHARGE SIZE	ELECTRICAL
MIM25C	25 lbs (11.3 kg)	1.9A/1.5A	62 lbs (28 kg) 75 lbs (34.2 kg)	R-600a 3.88 oz (110 g)	115V/60Hz/1Ph
MIM25CO	25 lbs (11.3 kg)	1.9A/1.5A	64 lbs (29 kg) 77 lbs (35.2 kg)	R-600a 3.88 oz (110 g)	115V/60Hz/1Ph
MIMC15C	15 lbs (11.4 kg)	1.2A/2.7A	50 lbs (23 kg) 55 lbs (27 kg)	R-600a 3.88 oz (110 g)	115V/60Hz/1Ph
MAXNG30	33 lbs (15 kg)	2.6A	35 lbs (15.9 kg) 39 lbs (17.7 kg)	R-134a 3.88 oz (110 g)	120V/180W



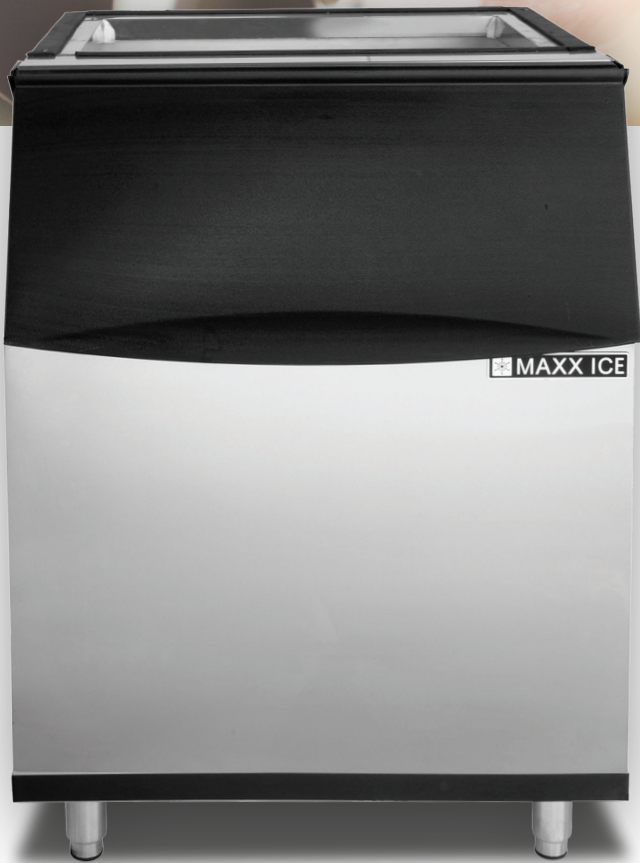

MAXX ICE

ICE STORAGE BINS

Ice Storage Bins are constructed of stainless steel and are compatible with both 22" and 30" Modular Ice Machines.



MB310N
22"W x 34"D x 41.4"H



MIB470N
30"W x 34"D x 41.4"H



MIB580N
30"W x 34"D x 50"H



MIB400
30"W x 34"D x 37"H



MIB580
30"W x 34"D x 50"H

MB310N/MIB470N/MIB580N Features:

- Exterior is constructed of durable stainless steel with black trim door
- LED illuminated bin interior when access door is open (powered by ice machine head)
- Polyethylene bin liner for improved sanitation
- Constructed of non-CFC polyurethane foamed in-place insulation
- 3/4" gravity drain is required
- Ice Storage Bin; stainless steel exterior, black trim

MIB400/MIB580 Features:

- Bin door and exterior are constructed of durable stainless steel
- Polyethylene bin liner for improved sanitation
- Constructed of non-CFC polyurethane foamed in-place insulation
- 3/4" gravity drain is required
- Ice Storage Bin; stainless steel exterior

MODEL #	MAXIMUM ICE STORAGE CAPACITY	AHRI CAPACITY	SHIPPING WEIGHT	DRAIN LINE CONNECTION
MIB310N <i>Formerly MIB280N</i>	310 lbs (141 kg)	246 lbs (112 kg)	99.5 lbs (45 kg)	3/4"
MIB470N <i>Formerly MIB430N</i>	470 lbs (213 kg)	376 lbs (171 kg)	117 lbs (53 kg)	3/4"
MIB580N	580 lbs (263 kg)	464 lbs (210 kg)	164 lbs (75 kg)	3/4"
MIB400	400 lbs (213 kg)	320 lbs (145 kg)	112 lbs (50.8 kg)	3/4"
MIB580	580 lbs (263 kg)	464 lbs (210 kg)	164 lbs (75 kg)	3/4"



BIN COMPATIBILITY



MODULAR ICE MACHINE MODEL #	MIB310N	MIB470N	MIB580N	MIB400	MIB580
MIM452		•	•	•	•
MIM600		•	•	•	•
MIM1000		•	•	•	•
MIM360N	•				
MIM360NH	•				
MIM370N		•	•	•	•
MIM370NH		•	•	•	•
MIM500N		•	•	•	•
MIM500NH		•	•	•	•
MIM650N		•	•	•	•
MIM650NH		•	•	•	•
MIM1000N		•	•	•	•
MIM1000NH		•	•	•	•

**With adapter kit, sold separately*



TLC-107096
4.125"W x 3.75"D x 18.5"H
Single Head with Pressure Gauge



TLC-107097
6"W x 5.25"D x 18.5"H
Double Head with Pressure Gauge



TLC-3200S
3.5"W x 3.5"D x 15.5"H
Replacement Cartridge

All Models Feature:

- NSF Approved, tested to ANSI and NSF 42
- Compatible with all Maxx Ice ice machines
- Provides ultra-fine 0.5 micron of filtration, inhibits unwanted bacteria from entering the water system for improved sanitation, taste and eliminate odors
- Gradient density carbon block filter is effective in contaminant reduction
- 95% average Chlorine reduction when using a premium filter eliminating odors and improves taste of ice as well as clarity
- Ice machine life is extended when a premium filter is installed and when the cartridge is changed every 6 months or when PSI is below 24
- Scale Inhibitor, SLO PHOS slow dissolving phosphate additive prevents scaling and scale build up
- Premium water filters help reduce sediments such as sand, rust and dirt from entering machine to ensure optimum operation, reducing daily operation costs and maintenance expenses
- Available in single and double head, with pressure gauge and replacement cartridges
- Sturdy manifold is supplied with a water pressure gauge with a tattle tale needle to track the water pressure highs and lows
- Maximum flow rate for single cartridge is 2.1GPM and filter life of 27,000 Gallons or 102,206 Liters
- Replacement cartridges can be "changed out" without turning OFF the ice machine

MODEL #	MAXIMUM FLOW RATE	PRESSURE	TEMPERATURE	FILTER LIFE (6 MOS)	MICRON RATING	SCALE INHIBITOR	IMPROVES ICE TASTE & CLARITY	REDUCES SEDIMENT	UNIT WEIGHT
TLC-107096	2.1 GPM	25-125 psi (1.7 - 8.6 bar)	35°F to 100°F (1.7°C to 38°C)	27,000 Gal (102,206 L)	0.5	Yes	Yes	Yes	2.75 lb (1.24 kg)
TLC-107097	4.2 GPM	25-125 psi (1.7 - 8.6 bar)	35°F to 100°F (1.7°C to 38°C)	54,000 Gal (204,412 L)	0.5	Yes	Yes	Yes	6.25 lb (2.83 kg)
TLC-3200S	2.1 GPM	25-125 psi (1.7 - 8.6 bar)	35°F to 100°F (1.7°C to 38°C)	27,000 Gal (102,206 L)	0.5	Yes	Yes	Yes	2.5 lb (1.13 kg)





TLC-2200S-STRK
3.83"W x 4.06"D x 15.3"H
Water Filter Starter Kit (Manifold + 1 Cartridge)



TLC-2200S
3.57"W x 3.57"D x 12.32"H
Water Filter Cartridge



TLC-2200S-DBLP
Water Filter Cartridge - 2 Pack



All Models Feature:

- NSF Approved, tested to ANSI and NSF 42
- Compatible with all Maxx Ice ice machines
- Provides ultra-fine 0.5 micron of filtration, inhibits unwanted bacteria from entering the water system for improved sanitation
- Gradient density carbon block filter is effective in contaminant reduction
- Ice machine life is extended when a value filter is installed and when the cartridge is changed every 6 months or when PSI is below 25
- Scale Inhibitor, SLO PHOS slow dissolving phosphate additive prevents scaling and scale build up
- Value water filters help reduce sediments such as sand, rust and dirt from entering machine to ensure optimum operation, reducing daily operation costs and maintenance expenses
- Sturdy manifold is supplied with a water pressure gauge with a tattle tale needle to track the water pressure highs and lows
- Maximum flow rate for single cartridge is 1.67GPM and filter life of 20,000 Gallons or 75,708 Liters
- Replacement cartridges can be "changed out" without turning OFF the ice machine

MODEL #	MAXIMUM FLOW RATE	PRESSURE	TEMPERATURE	FILTER LIFE (6 MOS)	MICRON RATING	SCALE INHIBITOR	IMPROVES ICE TASTE & CLARITY	REDUCES SEDIMENT	UNIT WEIGHT
TLC-2200S-STRK	1.67 GPM	25-125 psi (1.7 - 8.6 bar)	35°F to 100°F (1.7°C to 38°C)	20,000 Gal (75,708 L)	0.5	Yes	Yes	Yes	2.75 lb (1.24 kg)
TLC-2200S	1.67 GPM	25-125 psi (1.7 - 8.6 bar)	35°F to 100°F (1.7°C to 38°C)	20,000 Gal (75,708 L)	0.5	Yes	Yes	Yes	2.5 lb (1.24 kg)





MAXX ICE

COMPACT REFRIGERATION

Designed for both residential & commercial applications. Maxx Ice Compact Refrigerators are ideal for outdoor and indoor entertainment.

Units can be built-in or free-standing and are designed to weather the elements when necessary while providing years of enjoyment with easy maintenance.

COMPACT REFRIGERATION



MCR3U
14.5"W x 23"D x 33.5"H



MCR3U-O
14.5"W x 23"D x 33.5"H



MCR5U-O
23.625"W x 23"D x 33.5"H

MCR3U - Indoor Refrigerator; stainless steel door, black cabinet

MCR3U-O - Outdoor Refrigerator; stainless steel exterior

- Storage capacity of 3 cubic ft. (85 L)

Indoor/Outdoor Refrigerator; stainless steel exterior

- Storage capacity of 5 cubic ft. (142 L)

All Models Feature:

- Ideal for residential and commercial applications
- Stainless steel door with lock and key set
- Energy efficient LED interior lighting
- Digital controls maintain optimum temperature
- Free standing or built-in installation

MODEL #	HOLDING TEMPERATURE RANGE	AMP DRAW	DOORS/SHELVES	UNIT WEIGHT	REFRIGERANT AND CHARGE SIZE	ELECTRICAL
MCR3U	35°F to 40°F (1°C to 5°C)	2.0A	1/4	77 lbs (35 kg)	R-134a 2.3 oz (65.2 g)	115V/60Hz/1Ph
MCR3U-O	35°F to 40°F (1°C to 5°C)	2.0A	1/4	67 lbs (30 kg)	R-134a 2.2 oz (65.2 g)	115V/60Hz/1Ph
MCR5U-O	35°F to 40°F (1°C to 5°C)	1.8A	1/3	93 lbs (42.5 kg)	R-134a 2.2 oz (65.2 g)	115V/60Hz/1Ph





MAXX ICE

WINE COOLERS & BEVERAGE CENTERS

Maxx Ice Wine Coolers provide plenty of storage and accurate temperature to ensure your beverages taste good.

Our Beverage Centers are the perfect addition to any residential bar or kitchen application and can be installed outdoors.



MCWC28
14.5"W x 23"D x 33.5"H
Indoor Wine Cooler



MCBC3U
14.5"W x 23"D x 33.5"H
Indoor Beverage Center

All Models Feature:

- Designed for residential and commercial applications
- Storage capacity of 3 cubic ft. (85 L)
- Energy efficient LED interior lighting
- Electronic control panel with LCD digital display
- Multi-pane glass door with stainless steel handle
- Black painted steel exterior

MODEL #	HOLDING TEMPERATURE RANGE	AMP DRAW	BOTTLE RACKS/ BOTTLE CAPACITY	UNIT WEIGHT	REFRIGERANT AND CHARGE SIZE	ELECTRICAL
MCWC28	35°F to 40°F (1°C to 5°C)	2.0A	6/28	76 lbs (34 kg)	R-134a 2.3 oz (65.2 g)	115V/60Hz/1Ph
MCBC3U	35°F to 40°F (1°C to 5°C)	2.0A	1/4	77 lbs (35 kg)	R-134a 2.3 oz (65.2 g)	115V/60Hz/1Ph





MAXX ICE



A DIVISION OF
THE LEGACY COMPANIES

3355 Enterprise Avenue, Suite 160 | Fort Lauderdale, FL 33331
Tel: 954.202.7419 | Fax: 954.202.7337 | www.maxx-ice.com



@LegacyFoodservice

© 2024

