

TECHNICAL SPECIFICATIONS

MBS-1221 Multi Brewer

ELECTRICAL

Brewer SKU	Voltage	Heater Config.	Phase	Wires	kW	Connection	Max Amp Draw	[Gal] / [L] Hour	Certification
NORTH AMERICA									
M1221US-1A117-PM001	120	1 x 1.7 kW	1	2+G	1.7	NEMA 5-15P	14.7	4.4 / 16.7	NSF cULus
M1221US-1X117-PM001	120	1 x 1.7 kW	1	2+G	1.7	NEMA 5-15P	14.7	4.4 / 16.7	NSF cULus
DUAL VOLTAGE	208-240	1 x 3.0 kW	1	2+G	2.3-3.0	Terminal Block	11.3-13.0	7.0 / 26.5	NSF cULus
INTERNATIONAL									
M1221IN-1B130-PM005 ¹	200-240	1 x 3.0 kW	1	2+G	2.1-3.0	CEE 7/7	10.9-13.0	4.4 / 16.7	NSF cULus
M1221NM-1X117-PM001 ¹	100-120	1 x 1.7 kW	1	2+G	1.2-1.7	NEMA 5-15P	12.3-14.7	4.4 / 16.7	NSF NDM
DUAL VOLTAGE	200-240	1 x 3.0 kW	1	2+G	2.1-3.0	Terminal Block	10.9-13.0	7.0 / 26.5	NSF NDM
M1221CE-1B130-PM005 ¹	230	1 x 3.0 kW	1	2+G	2.8	CEE 7/7	12.5	7.0 / 26.5	NSF CE
M1221CE-1B130-PM006 ¹	230	1 x 3.0 kW	1	2+G	2.8	UK1-13P	12.5	7.0 / 26.5	NSF CE

WATER

Water Inlet	Water Pressure [psig] / [Bar]	Minimum Flow Rate [gpm] / [L/min]	Tank Capacity [Gal] / [L]
1/4" Male Flare	20-75 / 1.37-5.17	1.50 / 5.68	2.66 / 10.07

CUPS PER HOUR

Cup size	8 [oz] / 236 [ml]	12 [oz] / 355 [ml]	16 [oz] / 473 [ml]	20 [oz] / 591 [ml]
No. Cups per hour ²	112	75	56	45

DIMENSIONS & WEIGHT

	Height (A)	Width (B)	Depth (C)	Depth (D)	Faucet Clearance (E)	Brew Basket Clearance (F)	Open Shelf Clearance (G)	(H)	(I)	Empty Weight [lbs] / [kg]	Filled Weight [lbs] / [kg]
Product	36.63" 93.04 cm	9.25" 23.50 cm	17.00" 43.18 cm	22" 55.88 cm	30.00" 76.20 cm	22.63" 57.48 cm	11.25" 28.57 cm	12.00" 30.48 cm	14.875" 37.78 cm	37 lbs 16.7 kg	60 lbs 27.2 kg
Shipping	27.00" 68.60 cm	11.50" 29.20 cm	39.00" 99.06 cm	N/A	N/A	N/A	N/A	N/A	N/A	50 lbs 22.7 kg	N/A

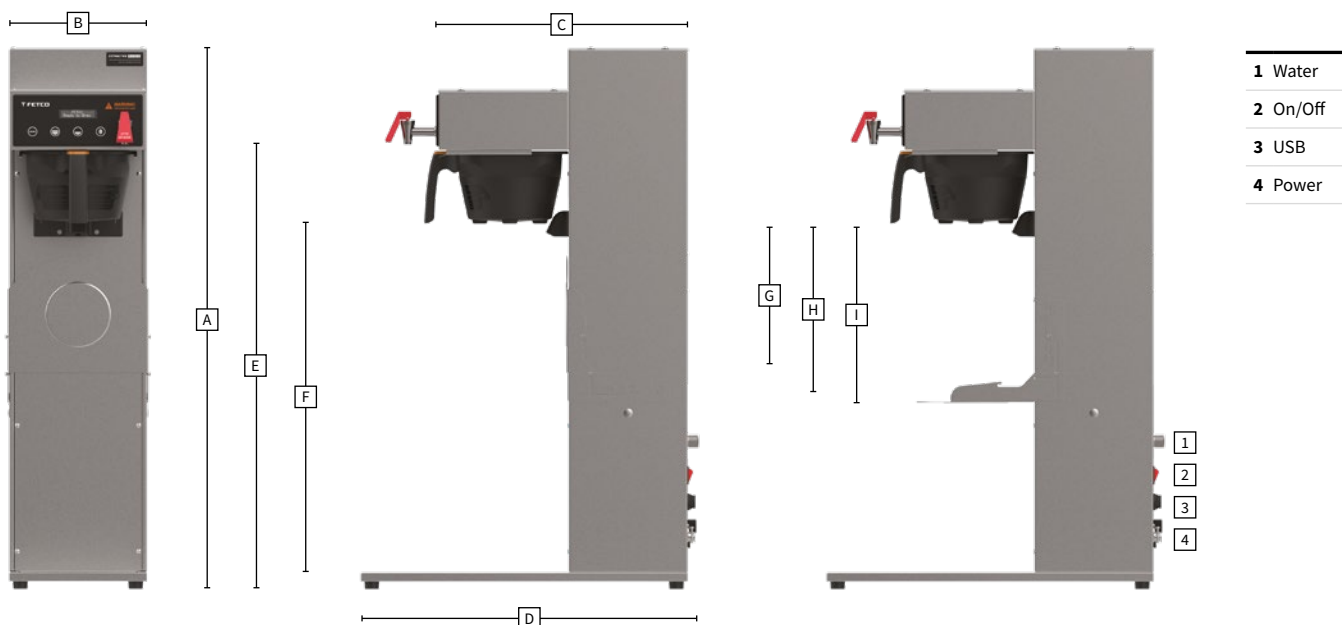

1 Made to order and may require longer lead time. Ask your local sales representative for more details.
2 Based on maximum power configuration.



WEBSITE
fetco.com

EMAIL
orders@fetco.com

PHONE
+1.847.719.3000
1.800.338.2699 USA

FAX
+1.847.719.3001

ADDRESS
Food Equipment Technologies Co.
600 Rose Road
Lake Zurich, IL 60047, USA

MULTI BEVERAGE BREWING SYSTEMS

MBS-1221 Multi Brewer

Shown with D064 3.5 Gallon Iced Tea Dispenser



MULTI BEVERAGE PROGRAMMING

Independently programmable for coffee and tea.



1 MACHINE, 3 SOLUTIONS

Brew three beverages — hot coffee, iced tea and iced coffee — from one small footprint. Three position shelf and wide base ensures flexibility to brew into virtually any dispenser.

DISPENSERS & ACCESSORIES

MBS-1221 Multi Brewer

DISPENSERS

D037
1.9 Liter Tall Server
NSF



D078
2.2 Liter Glass Lined Pump Lever Airpot
NSF



D080
2.2 Liter Pump Lever Airpot
NSF



D081
2.5 Liter Pump Lever Airpot
NSF



D041
3.0 Liter Pump Lever Airpot
NSF



D064 SQUARE
14.0 Liter / 3.5 Gallon LUXUS® Iced Tea Dispenser ITD-2135
NSF



D064 OVAL
14.0 Liter / 3.5 Gallon LUXUS® Iced Tea Dispenser ITD-1235
NSF



All dispensers **SOLD SEPARATELY**.



BREW BASKETS

Two brew baskets with different color clips — green for tea and brown for coffee — for easy differentiation.



CASCADING SPRAY DOME

Patented design provides even saturation of the coffee bed for maximum extraction. Lime resistant design for fewer service calls.

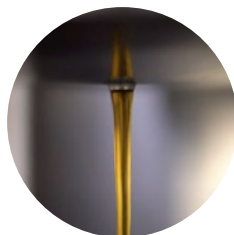

TRUE BREW TIME

Automatically manage net brew time independent from pre-wet and pulsing functions for easy adjustment of tea and coffee extraction.

ACCESSORIES, BASKETS AND FILTERS

Brewer SKU	Voltage	Brew Basket	Coffee Capacity	Tea Capacity	Filter Size	Filter SKU	Filter/Case
NORTH AMERICA							
M1221US-1A117-PM001	120	(2) 13" x 5"	3.5 oz/100 g	4.0 oz/100 g	13" x 5"	F002	500/cs
M1221US-1X117-PM001	Dual	(2) 13" x 5"	3.5 oz/100 g	4.0 oz/100 g	13" x 5"	F002	500/cs
INTERNATIONAL							
M1221IN-1B130-PM005	200-240	(2) 13" x 5"	3.5 oz/100 g	4.0 oz/100 g	13" x 5"	F002	500/cs
M1221NM-1X117-PM001	Dual	(2) 13" x 5"	3.5 oz/100 g	4.0 oz/100 g	13" x 5"	F002	500/cs
M1221CE-1B130-PM005	230	(2) 13" x 5"	3.5 oz/100 g	4.0 oz/100 g	13" x 5"	F002	500/cs
M1221CE-1B130-PM006	230	(2) 13" x 5"	3.5 oz/100 g	4.0 oz/100 g	13" x 5"	F002	500/cs

B014218BN2BK

13" x 5"
Coffee Plastic
Basket



B014140G2BK

13" x 5"
Tea Plastic
Basket



F002

13" x 5"
Paper Filters



Contact Customer Service or your Sales Person for more options.

WATER FILTRATION SYSTEM

Filtration System	SKU	Part	Rated Capacity	Working Pressure	Weight
Everpure®	A039	In-Line System	113,563 liters	10-125 psi [0.7-8.6 bar], non-shock	6.0 lbs / 2.7 kg
Everpure®	A075	Replacement Cartridge	113,563 liters	10-125 psi [0.7-8.6 bar], non-shock	6.0 lbs / 2.7 kg
BWT Bestmax	A138	In-Line System	3,002 liters	29-116 psi [2-8 bar], non-shock	11.0 lbs / 5.0 kg
BWT Bestmax	A139	Replacement Cartridge	3,002 liters	29-116 psi [2-8 bar], non-shock	11.0 lbs / 5.0 kg
BWT Bestmax	A140	In-Line System	4,562 liters	29-116 psi [2-8 bar], non-shock	11.0 lbs / 5.0 kg
BWT Bestmax	A141	Replacement Cartridge	4,562 liters	29-116 psi [2-8 bar], non-shock	11.0 lbs / 5.0 kg

EVERPURE®

In-Line Water
Filtration System



SET INCLUDES: 1ea. commercial quality corrosion resistant filter head 1ea. taste and odor filter cartridge (FETCO® #A075) / 1ea. 3/8" x 4' connection hose / 1 set — mounting bracket and hardware.

- Recommended for large-sized operations
- Taste and odor filter for extremely turbid (cloudy) water
- Granular-activated carbon reduces sediment and chlorine
- Quick-disconnect style head/cartridge design cartridge for effortless replacement
- Durable, corrosion-resistant head includes built-in shutoff valve

BWT BESTMAX

In-Line Water
Filtration System



SET INCLUDES: 1ea. filter cartridge / 1ea. universal filter head / 1ea. wall mounting bracket Braided hose supplies 3/8" and 3/4" compression, in 24" or 48" lengths

- Recommended for small- to medium-sized operations
- Carbonate hardness removal prevents scale deposits and retains minerals
- Granular-activated carbon reduces sediment and chlorine
- Quick-disconnect style head/cartridge design cartridge for effortless replacement
- Durable, corrosion-resistant head includes built-in shutoff valve
- Four bypass settings allows for different water qualities and product preferences