

INSTRUCTION MANUAL

MONTAGUE LEGEND

Gas Fired Heavy Duty Ranges

MODELS:

12, 18, 24 & 36 Series
M12, M18, M24 & M36 Series
124 & 136 Series

These instructions should be read thoroughly before attempting installation.
Set up and installation should be performed by qualified installation personnel.

Keep area around appliances free and clear from combustibles.

PLEASE RETAIN THIS MANUAL
FOR FUTURE REFERENCE.



THE MONTAGUE COMPANY

1830 STEARMAN AVENUE, P.O. BOX 4954

HAYWARD, CA 94540-4954

TEL: 510/785-8822 FAX: 510/785-3342

CONTENTS

| | |
|---------------------|----|
| INSTALLATION | 1 |
| OPERATION | 8 |
| COOKING HINTS | 11 |

| | |
|-------------------|----|
| MAINTENANCE | 16 |
| SERVICE | 18 |

IMPORTANT

WARNING:

Improper installation, adjustment, alteration, service or maintenance can cause property damage, injury or death. Read the operating and maintenance instructions thoroughly before installing or servicing this equipment.

FOR YOUR SAFETY:

Do not store or use gasoline or other flammable vapors and liquids in the vicinity of this or any other appliance.

INSTRUCTIONS TO BE FOLLOWED IN THE EVENT THE USER SMELLS GAS MUST BE POSTED IN A PROMINENT LOCATION. THIS INFORMATION MAY BE OBTAINED BY CONSULTING THE LOCAL GAS SUPPLIER.

SHIPPING DAMAGE CLAIM PROCEDURE

For your protection, please note that equipment in this shipment was carefully inspected and packed by skilled personnel before leaving the factory. The transportation company assumed full responsibility for safe delivery upon acceptance of this shipment.

If shipment arrives damaged:

1. **VISIBLE LOSS OR DAMAGE** - Be certain this is noted on freight bill or express receipt, and signed by person making delivery.
2. **FILE CLAIM FOR DAMAGES IMMEDIATELY** - Regardless of the extent of damage.
3. **CONCEALED LOSS OR DAMAGE** - If damage is unnoticed until merchandise is unpacked, notify transportation company or carrier immediately, and file "concealed damage" claim with them. This should be done within fifteen (15) days of date that delivery was made to you. Be sure to retain container for inspection.

We cannot assume responsibility for damage incurred in transit. We will, however, be glad to furnish you with necessary documents to support your claim.

INSTALLATION

The Montague gas ranges are manufactured for use with the type of gas indicated on the nameplate.

The Montague heavy duty gas ranges are produced with the best possible material and workmanship.
PROPER INSTALLATION IS ESSENTIAL FOR SAFE AND EFFICIENT TROUBLE-FREE OPERATION.

THE INSTALLATION INSTRUCTIONS CONTAINED HEREIN ARE FOR THE USE OF QUALIFIED INSTALLATION AND SERVICE PERSONNEL ONLY. INSTALLATION OR SERVICE BY OTHER THAN QUALIFIED PERSONNEL MAY RESULT IN DAMAGE TO THE OVEN AND/OR INJURY TO THE OPERATOR.

Qualified installation personnel are individuals, a firm, corporation or company which either in person, or through a representative are engaged in, and are responsible for:

- A.** The installation or replacement of gas piping or the connection, installation, repair or servicing of equipment, who is experienced in such work, familiar with all precautions required, and has complied with all requirements of state or local authorities having jurisdiction. Reference: National Fuel Gas Code Z223.1, Section 1.4.
- B.** The installation of electrical wiring from the electric meter, main control box or service outlet to the electric appliance. Qualified installation personnel must be experienced in such work, be familiar with all precautions required and have complied with all requirements of state and local authorities having jurisdiction. Reference: National Electric Code, ANSI/NFPA No. 70.

READ CAREFULLY AND FOLLOW THESE INSTRUCTIONS

THE RANGE(S) MUST BE INSTALLED IN ACCORDANCE WITH LOCAL CODES, OR IN THE ABSENCE OF LOCAL CODES, WITH THE NATIONAL FUEL GAS CODE, ANSI Z223.1- LATEST ADDENDA, INCLUDING:

- 1. The appliance and its individual shutoff valve must be disconnected from the gas supply piping system during any pressure testing of that system at test pressures in excess of 1/2 psig. (3.45 kPa).**
- 2. The appliance must be isolated from the gas supply piping system by closing its individual manual shutoff valve during any pressure testing of the gas supply piping system at test pressure equal to or less than 1/2 psig. (3.45 kPa).**

PROVISIONS MUST BE MADE FOR ADEQUATE AIR SUPPLY TO THE UNIT.

INSTALLATION

VENTILATING HOOD

The range(s) must be installed under a properly designed ventilating hood. The hood should extend at least 6" beyond all sides of the unit. The hood should be connected to an adequate mechanical exhaust system.

Information on the construction and installation of ventilating hoods may be obtained from the "Standard for the Installation of Equipment for the Removal of Smoke and Grease Laden Vapors from Commercial Cooking Equipment", NFPA No. 96, available from the National Fire Protection Association, Batterymarch Park, Quincy, MA 02269.

It is also necessary that sufficient room air ingress be allowed to compensate for the amount of air removed by the ventilating system. Otherwise, a subnormal atmospheric pressure will occur which may interfere with burner performance or may extinguish the pilot flame. In case of unsatisfactory range performance, check with the exhaust fan in the "OFF" position.

CLEARANCES

Adequate clearance must be provided in aisle and at the side and back to allow the doors to open sufficiently to permit the removal of the racks and for serviceability. Adequate clearance for air openings into the combustion chamber must be provided.

| | CLEARANCES COMBUSTIBLE CONSTRUCTION | NONCOMBUSTIBLE CONSTRUCTION |
|-------------------|---|--------------------------------|
| BACK | 2" | 0" |
| LEFT & RIGHT SIDE | 6" | 0" |

WITH 4" OR 6" LEGS: SUITABLE FOR INSTALLATION ON COMBUSTIBLE FLOORS.
WITHOUT LEGS: FOR USE ONLY ON NONCOMBUSTIBLE FLOORS.

*15" WHEN EQUIPPED WITH OPTIONAL 30,000 BTU/HR EACH OPEN TOP
BURNER(S).

CAUTION
DO NOT OBSTRUCT THE FLOW OF COMBUSTION AND VENTILATION AIR TO
THE RANGE. KEEP THE APPLIANCE AREA FREE AND CLEAR FROM
COMBUSTIBLES.

ASSEMBLY

Uncrate range as near to final location as possible. Remove all shipping wire from burners and all packing material and accessories from oven interior. Then assemble as follows:

1. Screw the adjustable feet of the legs in all the way. Then tightly screw the complete leg assembly into the mounting holes at each corner of the range. If the unit is intended for curb installation, no legs are provided. The curb must be noncombustible material.
2. Install door handle and secure with screws that are provided. Observe "UP" marking on handle for correct orientation.
3. If top castings are removed, identify castings so they are replaced in the same position and on same range as when received from the factory.

SETTING IN PLACE

BATTERY ARRANGEMENT

FLOOR MOUNTED RANGES:

1. Place the first range in the exact position it will occupy in the battery.
2. Using a carpenter's level, level range from front to rear and side to side. Adjust as follows:

FLOOR INSTALLATION ON LEGS: Adjust by turning foot on adjustable leg.

CURB INSTALLATION ON LEGS: Place shim under the low side. This operation is important since variation in floor and curbs are common. Unless ranges are level, difficulty will be encountered in aligning the gas ranges are level, difficulty will be encountered in aligning the gas supply manifold and the ranges will not butt together tightly.

3. Remove the upper valve panel from range.
4. Move the next range into position.
5. Engage union nut on manifold with male fitting on next range and draw up union nut hand tight. Be sure appliances butt together both front and rear. If manifolds do not align, then ranges are not level. In extreme cases, it may be necessary to loosen manifold bolts and adjust.
6. Continue leveling and connecting gas supply manifolds together until all appliances in battery are connected.
7. Tighten front manifold pipe union gas tight. Use back up wrench to prevent manifold from rotating. **FAILURE TO DO THIS MAY RESULT IN DAMAGE TO PILOTS AND GAS VALVES.**

SERVICE

MODULAR RANGES:

Assemble modular base and set in place. Adjust feet as explained above. Connect ranges as shown for battery arrangement.

FRY TOP RANGES:

Fry Top Plate Adjustment: Leveling bolts are at the rear of the range under the fry top plate. Adjust leveling bolts so that the plate is pitched to the front to provide for grease runoff. (See Fig. 1)

HIGH SHELVES AND SALAMANDER BROILERS:

Lift high shelf or broiler above the range and slide legs into position. (See Fig.2)

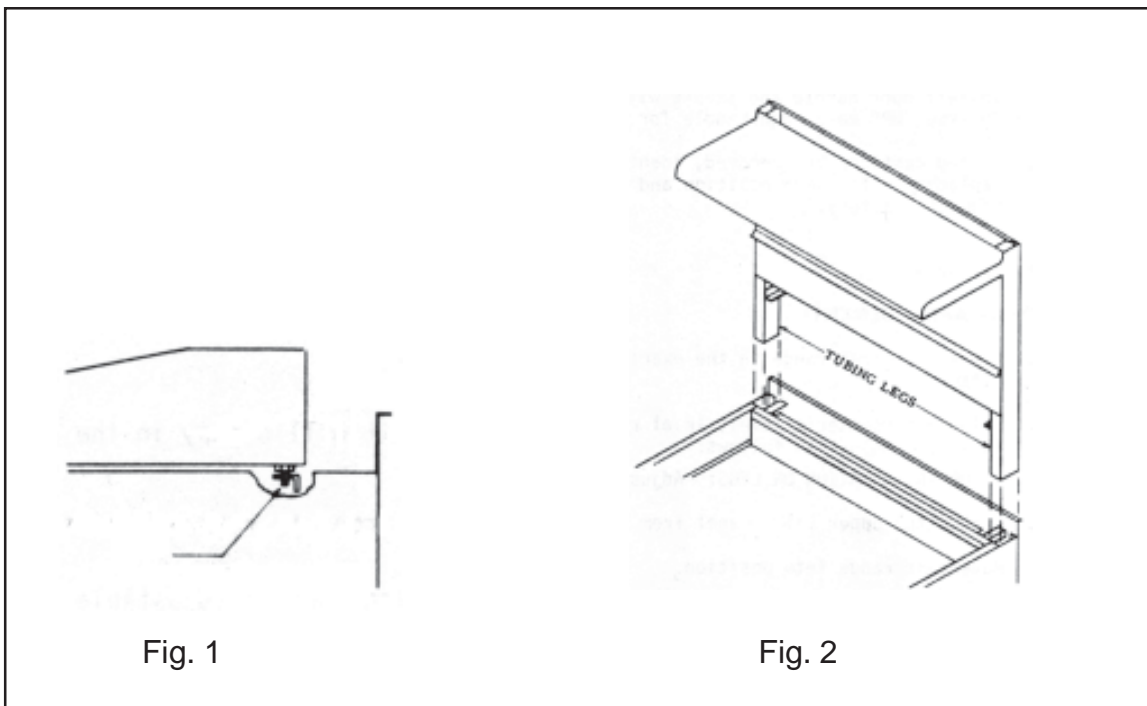

GAS APPLIANCE REGULATOR

A GAS APPLIANCE PRESSURE REGULATOR SUITABLE FOR THE BATTERY APPLICATION AND ADJUSTED FOR THE MANIFOLD PRESSURE SPECIFIED ON THE RANGE NAMEPLATE MUST BE FURNISHED BY THE INSTALLER AT THE TIME OF INSTALLTION.

Unless otherwise specified, the range is equipped with fixed orifices for use with a manifold pressure of 6.0" water column for natural gas and 10.0" water column for propane gas.

The gas pressure regulator furnished by the installer must comply with the following:

1. The pressure regulator(s) must have a maximum regulation capacity for the total connected load.
2. The pressure regulator(s) installed must be listed by a nationally recognized testing agency.
3. The pressure regulator(s) must have a pressure adjustment range to allow adjustment to the manifold pressure on the appliance rating plate.
4. Unless the manifold pressure on all connected appliances is the same, a separate pressure regulator must be supplied for each appliance(s) having differing manifold pressures.

GAS CONNECTION

Before connecting the range battery to the gas supply line, be sure that all new piping has been cleaned and purged to prevent any foreign matter from being carried into the controls by the gas. In some cases, filters or drops are recommend. A separate Gas Shut off Valve must be installed upstream from the gas pressure regulator adjacent to the range battery and located in an accessible area.

WARNING: CAP ALL UNUSED OPEN ENDS OF THE GAS SUPPLY MANIFOLD.

It is important that adequately sized piping be run directly to the point of connection at range battery with as few elbows and tees as possible. Consult local gas company for proper piping size and gas pressure.

PIPE JOINT COMPOUND OR THREAD SEALANT THAT IS USED SHOULD BE RESISTANT TO ACTION OF LIQUEFIED PETROLEUM GASES.

Turn Gas Shut Off Valve "ON" and immediately check carefully for gas leaks. Do this before attempting to operate the range battery.

SERVICE

TEST ALL PIPE JOINTS FOR LEAKS BEFORE OPERATING RANGE(S). THIS INCLUDES ALL GAS CONNECTIONS THAT MAY HAVE LOOSENED DURING SHIPMENT. USE A RICH SOAP SOLUTION (OR OTHER ACCEPTED LEAK TESTER) AROUND ALL PIPE CONNECTIONS AND ALL OTHER JOINTS. DO NOT USE AN OPEN FLAME. ABSOLUTELY NO LEAKAGE SHOULD OCCUR, OTHERWISE THERE IS A DANGER OF FIRE OR EXPLOSION DEPENDING UPON CONDITIONS. NEVER USE IF LEAKAGE IS DETECTED.

PILOT ADJUSTMENT-TOP BURNERS

OPEN TOP: The front and rear pilots are controlled by one valve. To adjust pilot, turn adjusting screw counter-clockwise to increase or clockwise to decrease pilot flame. Adjust flame to a point where only a trace of yellow tip remains.

HOT TOP & FRY TOP: Each pilot is controlled by a pilot valve. Turn adjusting screw until pilot flame is 1/2" high.

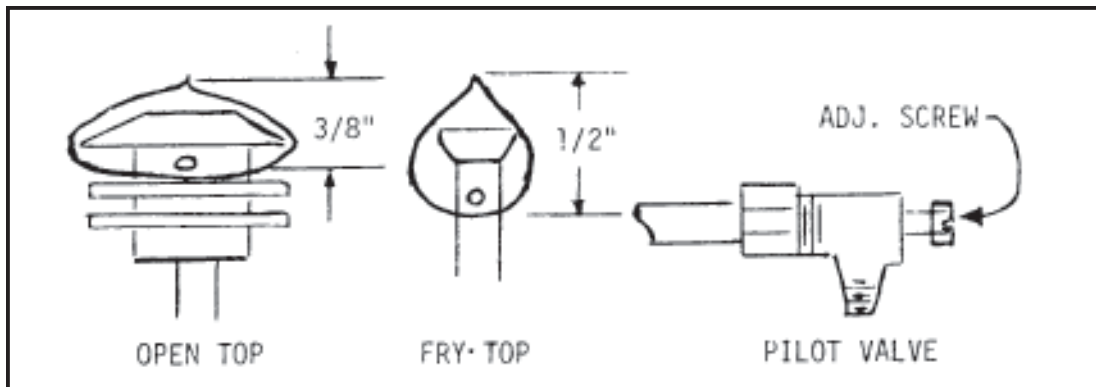

BURNER ADJUSTMENT

The efficiency of the range depends on a delicate balance between the supply of air and volume of gas so that complete combustion is achieved. Whenever this balance is disturbed, poor operating characteristics occur.

The air supply is controlled by an air shutter on the front of the burner. The air shutter openings should be increased until the flame on the burner begins to "lift". The air shutter should then be closed slightly and locked in place. A yellow streaming flame indicates insufficient air. This condition can be corrected by increasing the air shutter opening.

FRY TOP AND OVEN THERMOSTATS

The bypass (minimum burner flame) has been adjusted at factory and should require no further adjustment if the gas manifold pressure is correct.

THE BYPASS FLAME MUST BE RECHECKED WHEN PERFORMING CHECKOUT OF RANGE PRIOR TO PLACING EQUIPMENT IN SERVICE. THE BYPASS MUST BE SET CAREFULLY AND ACCURATELY. REFER TO SERVICE SECTION OF THIS MANUAL FOR PROPER PROCEDURE.

SERVICE

OPERATING INFORMATION FOR THE RANGE HAS BEEN PREPARED FOR USE BY QUALIFIED AND/OR PROFESSIONAL OPERATING PERSONNEL.

CAUTION
DO NOT OBSTRUCT THE FLOW OF COMBUSTION AND VENTILATION AIR TO THE RANGE. KEEP THE APPLIANCE AREA FREE AND CLEAR FROM COMBUSTIBLES.

GAS CONTROLS

IN THE EVENT A GAS ODOR IS DETECTED, SHUT DOWN UNITS AT MAIN SHUT OFF VALVE AND CONTACT THE LOCAL GAS COMPANY OR GAS SUPPLIER FOR SERVICE.

TOP BURNERS-OPEN, HOT TOP AND MANUAL FRYTOP

Check that pilots are burning. Then rotate valve handles counter clockwise to full on, burner will ignite automatically. Adjust flame height as desired. To shut down, rotate valve handle clockwise to "OFF" position.

FRY TOP-THERMOSTAT CONTROLLED

Check that pilot(s) are burning. Then push thermostat dial inward and rotate dial counter-clockwise to maximum thermsotat setting, burner(s) will ignite automatically. After ignition, turn thermostat dial to desired setting. To shut down, rotate thermostat dial clockwise to "OFF" position.

OVEN - 136 SERIES

A. Lighting

Turn burner valve to "OFF" position and wait five (5) minutes.

1. Remove burner compartment cover and open pilot access door.
2. Press and hold red button in (Safety Pilot Valve) and apply lighted match to pilot burner.
3. After pilot burner ignites, continue to hold red button depressed for 30 to 45 seconds or until pilot remains burning when button is released. If pilot goes out, repeat process.
4. Close pilot access door and replace burner compartment cover.
5. Turn burner valve on and rotate thermostat dial counter-clockwise to desired temperature setting.
6. IN THE EVENT OF PILOT FAILURE, TURN BURNER VALVE CLOCKWISE TO "OFF" POSITION AND WAIT FIVE (5) MINUTES FOR UNBURNED GAS TO ESCAPE FROM RANGE.

B Shut Down

Turn burner valve clockwise to "OFF" position.

OVEN OPERATION - 136 SERIES

1. Turn burner valve "ON" and turn thermostat dial to desired temperature.
2. Limit preheat time to 20 to 30 minutes.
3. Place food in oven. Make sure pans do not touch each other, or the oven walls.
4. Do not cover racks with aluminum foil.
5. Load and unload quickly. Avoid frequent opening of door.
6. Turn off when not in use.

OVEN - 124 SERIES

A. Lighting

Turn thermostat knob to "OFF" position and wait five (5) minutes.

1. Remove burner compartment cover and open pilot access door.
2. Locate the piezo igniter in front of the pilot access door.
3. Press and hold red button in (Safety Pilot Valve) and repeatedly depress the button on the piezo igniter until the pilot burner ignites.
4. After pilot burner ignites, continue to hold red button depressed for 30 to 45 seconds or until pilot remains burning when button is released. If pilot goes out, repeat process.
5. If the pilot burner is unable to be lit with the piezo igniter, apply a lighted match to the pilot burner.
6. Close pilot access door and replace burner access panel.
7. Push thermostat dial inward and rotate dial counterclockwise to desired temperature setting.
8. IN THE EVENT OF PILOT FAILURE, ROTATE THERMOSTAT DIAL CLOCKWISE TO "OFF" POSITION AND WAIT FIVE (5) MINUTES FOR UNBURNED GAS TO ESCAPE FROM RANGE.

B Shut Down

Rotate thermostat dial clockwise to "OFF" position.

OVEN OPERATION - 124 SERIES

1. Turn thermostat dial to desired temperature.
2. Limit preheat time to 10 to 20 minutes.
3. Place food in oven. Make sure pans do not touch each other, or the oven walls.
4. Do not cover racks with aluminum foil.
5. Load and unload quickly. Avoid frequent opening of doors.
6. Turn off when not in use.

SERVICE

SUGGESTIONS

- * Break the habit of turning on all your equipment first thing every morning. Unless you plan to use a piece of equipment, leave it off until it's needed.
- * There is no need to preheat an open top burner. Use full flame to start foods cooking quickly; reduce flame to simmer foods. Regulate the burners so that flame tips just touch the bottom of the utensil. Use lids on pots to keep heat in. Turn burner off when not in use.
- * Limit preheat time to 10-15 minutes on hot top ranges using full flame. Use flat bottom pans for efficient use of heat in. During idling period, use low flame or turn one or more burners off. Heat only section of hot top required.
- * Preheat fry top 10-15 minutes prior to use. Usually, a medium or low flame is adequate for light frying. If fry top has a thermostat, use it to avoid wasting gas and for best results. During slack periods, turn the burner down.

CARE AND CLEANING

The complete range should be given a periodic general cleaning. Lint and grease suspended in the air tend to collect in passages. Therefore, all flueways, air passages and openings, burner ports, primary air openings, etc. should be periodically cleaned to prevent clogging.

EXTERIOR

PAINTED SURFACE: Allow equipment to cool after use and wash with a mild detergent or soap solution. Dry thoroughly with a dry cloth.

STAINLESS STEEL SURFACE: To remove dirt, grease, or product residue, from stainless steel use ordinary soap solution. Dry thoroughly with a clean cloth.

To remove grease and food splatter, or condensed vapors, that have baked on the equipment apply cleanser to a damp cloth or sponge and rub cleanser on the metal in the direction of the polishing lines on the metal. Rubbing cleanser as gently as possible in the direction of the polished lines will not mar the finish of the stainless steel. **NEVER RUB WITH A CIRCULAR MOTION.** Soil and burnt deposits which do not respond to the above procedure can usually be removed by rubbing the surface with SCOTCH-BRITE scouring pads or STAINLESS scouring pads. **DO NOT USE ORDINARY STEEL WOOL** as any particles left on the surface will rust and further spoil the appearance of the finish. **NEVER USE A WIRE BRUSH, STEEL SCOURING PADS (EXCEPT STAINLESS), SCRAPER, FILE OR OTHER STEEL TOOLS.** Surfaces which are marred collect dirt more rapidly and become more difficult to clean. Marring also increases the possibility of corrosive attack.

To remove heat tint: Darkened areas sometimes appear on stainless steel surfaces where the area has been subjected to excessive heat. These darkened areas are caused by thickening of the protective surface of the stainless steel and are not harmful. Heat tint can normally be removed by the foregoing, but tint which does not respond to this procedure calls for a vigorous scouring in the direction of the polish lines, using SCOTCH-BRITE scouring pads or a STAINLESS scouring pad in combination with a powdered cleanser. Heat tint action may be lessened by not applying or by reducing heat to equipment during slack periods.

OVEN INTERIOR

STANDARD FINISH (Porcelain Enamel): Frequent cleaning is required. Spillovers should be cleaned as soon as possible to prevent carbonizing and a burnt-on condition. Wait until oven is cool for complete cleaning. Usually a soap or detergent solution is strong enough to remove any grease residue. A mild abrasive nylon cleaning pad may be used for stubborn spillovers or stains. Non-caustic commercial oven cleaners may be used, but do not allow cleaners to come in contact with the temperature probe. Wipe off all oven cleaner residue.

OPEN TOP SECTION

DAILY: Wipe top with burlap or other grease absorbing material to remove spillovers, grease, etc., before they burn in.

WEEKLY: Open Top Section should be washed in a solution of washing soda and water (after they are entirely cooled.) Remove and wash drip pan under burners. Brush burner head weekly with a stiff wire brush and clean clogged ports with stiff wire or ice pick. Excessive grease build up may be removed from burners by soaking in a solution of washing soda. Dry burners by inverting on oven rack in a low temperature oven.

HOT TOP SECTION

DAILY: Wipe top with heavy burlap or steel wool, rub briskly until clean. Lift rings and plates to clean all flanges and under lid. **NEVER POUR WATER ON A HOT TOP SECTION.**

FRY TOP SECTION

DAILY: Use flat edge of spatula or metal scraper to keep surface free of encrusted material during use, wipe frequently with heavy absorbent cloth. After griddle is cooled, polish with soft griddle stone or a good grade grill pad. **DO NOT SCRATCH.** The griddle may be washed with warm water and a cleanser. Water will not crack this griddle plate.

To oil the griddle, use a hydrogenated shortening. Never use salad oils, margarine or butter, as these shortenings cannot withstand temperatures greater than 300 °F.

SERVICE

WHEN SERVICE IS NEEDED, CONTACT A LOCAL SERVICE COMPANY, DEALER, OR FACTORY TO PERFORM MECHANICAL MAINTENANCE AND REPAIRS. THESE INSTRUCTIONS ARE INTENDED FOR USE BY COMPETENT SERVICE PERSONNEL.

CAUTION: TURN OFF GAS SUPPLY WHEN SERVICING GAS CONTROL SYSTEM.

SAFETY PILOT VALVE

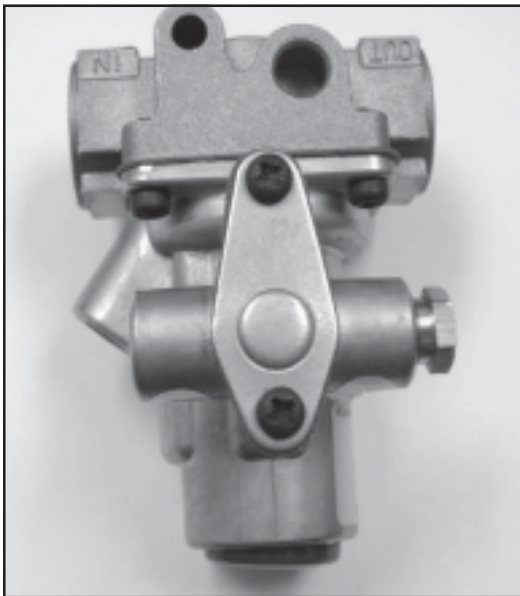

Model H15HR is an automatic 100% safety pilot which provides complete gas shut off in event of pilot failure. The safety valve is held closed by spring pressure. When red button is pushed by hand, gas flows to pilot. Pilot heats thermocouple creating a very small amount of electricity. This energizes a magnetic coil under the red button and holds valve open, permitting gas to flow to main burner and pilot without holding pressure on red button. In the event of pilot failure, the flow of electricity will stop and spring will stop flow of gas to both pilot and oven burner.

OVEN PILOT BURNER

PILOT SERVICE IN THE EVENT OF PILOT FLAME FAILURE

1. If pilot flame burns yellow, clean pilot orifice and pilot burner to insure a steady blue flame. The P/N 010138 orifice can be cleaned by Pilot Burner washing in a solvent and/ or blowing out with air.
2. Flame must surround the thermocouple tip for approximately 1/2 inch.

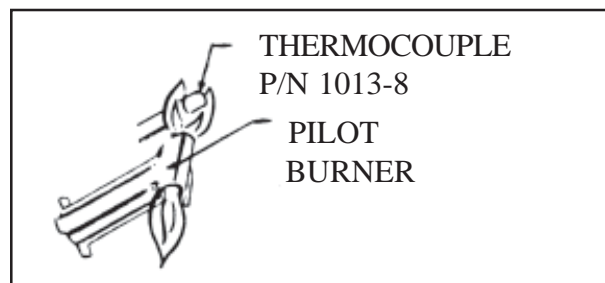

| THERMOCOUPLE OUTPUT | |
|----------------------------|---------------|
| CLOSED CIRCUIT MV RANGE | |
| NORMAL | NOT LESS THAN |
| 15-25 | 8 |

If the closed circuit check shows thermocouple output is greater than 8 millivolts and pilot will not remain lit when reset button is released, replace safety pilot valve.

3. Thermocouple lead connections must be tight, clean, and free of grease. The thermocouple nut should be started and turned all the way by hand. An additional quarter turn with a small wrench will then be sufficient.

CAUTION: OVERTIGHTENING MAY CAUSE DAMAGE TO THE THERMOCOUPLE OR MAGNET AND IS UNNECESSARY SINCE THIS IS AN ELECTRIC CONNECTION.

FRY TOP THERMOSTAT

The Model BJ Robertshaw is a combination thermostat and gas valve. The gas is turned on and the temperature setting made by a single rotation of the dial. This valve automatically locks itself in the OFF position. To use, push dial inward, rotate counterclockwise to the desired temperature. To shut gas off, rotate clockwise to OFF position.

This thermostat is a precision instrument carefully made and properly calibrated (i.e. the dial is properly set) at the factory to control temperatures accurately. It should control temperatures for the proper cooking of food without recalibration. The calibration of this thermostat should not be changed until considerable experience with cooking results has definitely proved that the thermostat is not maintaining the proper temperature.

CAUTION: THE RECALIBRATION SHOULD NOT BE MADE UNTIL THE BYPASS (MINIMUM BURNER) FLAME HAS BEEN PROPERLY ADJUSTED.

THERMOSTAT INSTALLATION

With front of the griddle plate raised, slide the thermostat bulb assembly into the support brackets attached to the underside of the fry top plate. Tighten the two holding screws. The excess capillary tube should be pulled forward and down as low as possible out of the heat zone, so that there is no chance of it coming in contact with the burner flame. Push the sleeving up against the bulb holder. A loose fit between the bulb holder and plate may damage the thermostat so that it will not control the temperature of the fry top plate.

SERVICE

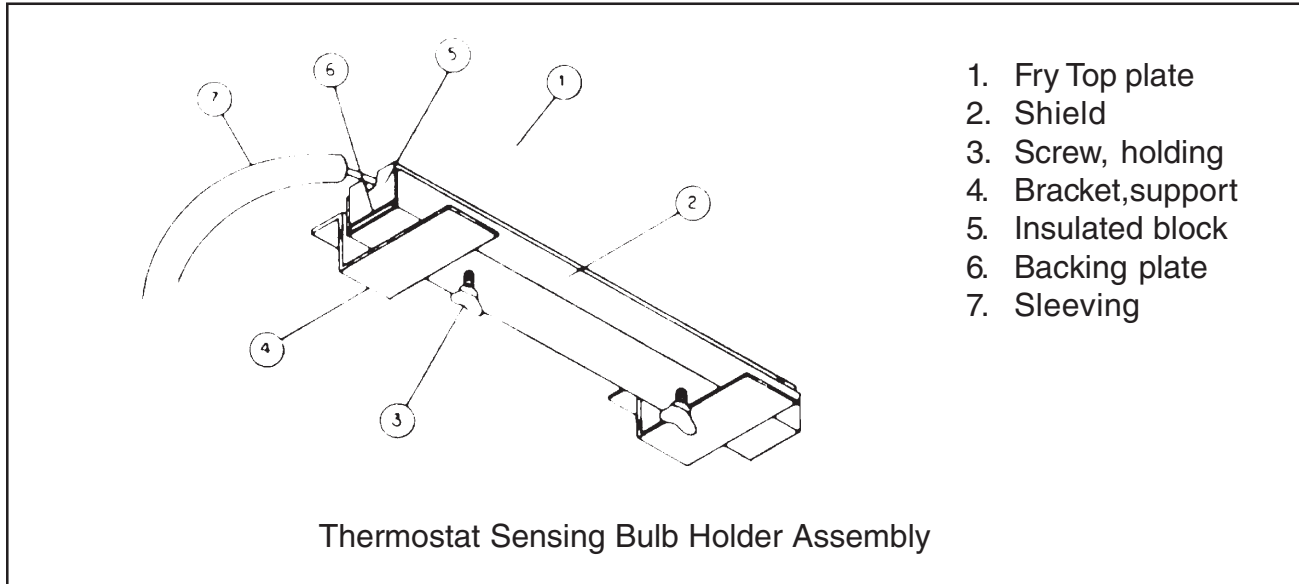

ADJUSTMENT OF BYPASS (MINIMUM BURNER) FLAME

This is the flame which must be maintained on the burners when the fry top has reached the temperature set on the dial. Enough gas must be bypassed by the control to keep the entire burner lit. The thermostat regulates the flame from high to low in accordance with the fry top temperature and will automatically turn down to this bypass flame when the temperature set on the dial is attained.

Special care should be taken to see that the thermostat bulb is in its proper place and no part of the capillary tube is in any flame or heat zone. The fry top plate should never be removed without first removing the thermostat bulb(s) from beneath the plate. Never allow capillary tube to be kinked or crushed.

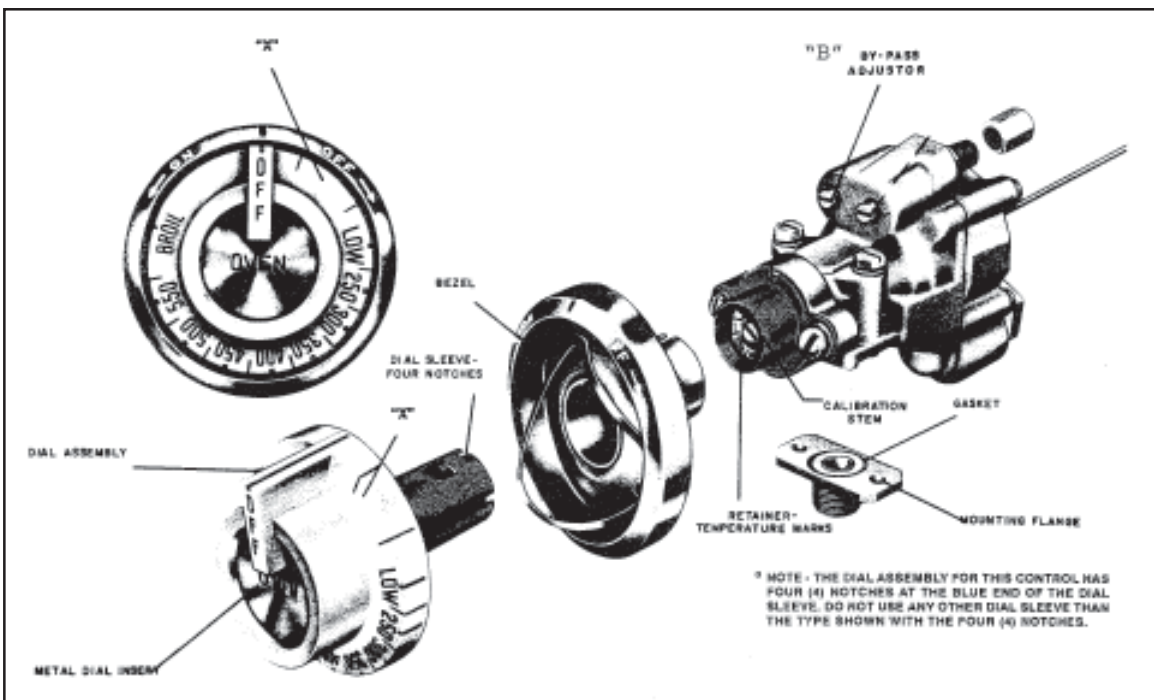

THE BYPASS MUST BE SET CAREFULLY AND ACCURATELY AS FOLLOWS:

1. Light burners and turn Dial (A) counterclockwise and to a point midway between the "Gas On" mark and the next graduation to the right of it (shown by "V"). If the burner goes out entirely, the bypass is closed.
2. Slip off Dial (A). Remove the valve panel from the front of the range.
3. With a screwdriver turn bypass adjustor (B). Turning it out counterclockwise increases the bypass flame; turning it in clockwise decreases the bypass flame. Adjust until there is a flame approximately 1/8" high over the entire burner.
4. Replace dial, rotating dial clockwise until it snaps into its original position.
5. Reinstall the valve panel on front of the range.

FRY TOP THERMOSTAT CALIBRATION CHECK:

The fry top temperature should be checked or recalibrated with fry top hot. NOTE: See "Adjustment of Bypass (Minimum Burner) Flame" before recalibrating this thermostat.

HOT CHECK METHOD:

1. Place reliable thermometer in center of the top of the fry top over the thermal bulb.
2. Set Dial (A) to 350 ° .
3. Wait until temperature rises and remains constant.
4. If dial does not agree with thermometer readings, slip off Dial (A) and push out metal insert.
5. Replace dial, turn to 350 ° mark.
6. Hold dial firmly, insert screwdriver through center of dial and push calibration stem (C) inward. DO NOT TURN THIS STEM.
7. While holding calibration stem (C) infirmly wi th screwdriver, turn dial until it is set at the actual fry top temperature as shown by the thermometer. Release pressure on calibration stem. Replace dial insert.

OVEN THERMOSTAT - 136 SERIES

All adjustments are accessible from the front of the range after the dial and the front panel have been removed. To remove dial, grasp knob portion firmly and pull. This will expose the calibration plate. Dial is held to the shaft with a friction fit. There are no screws.

SERVICE

Field recalibration is seldom necessary, and should not be resorted to unless experience with cooking results definitely proves that the control is not maintaining the temperature to which the dial is set. To check oven temperatures when recalibrating use a Robertshaw Test Instrument or a reliable mercury oven thermometer.

CAUTION: THE RECALIBRATION SHOULD NOT BE MADE UNTIL THE BYPASS (MINIMUM BURNER) FLAME HAS BEEN PROPERLY ADJUSTED.

ADJUSTMENT OF BYPASS (MINIMUM BURNER FLAME) - 136 SERIES

Enough gas must be bypassed through the heat control to keep the entire burner lit while in use. The control regulates the flame from high to low.

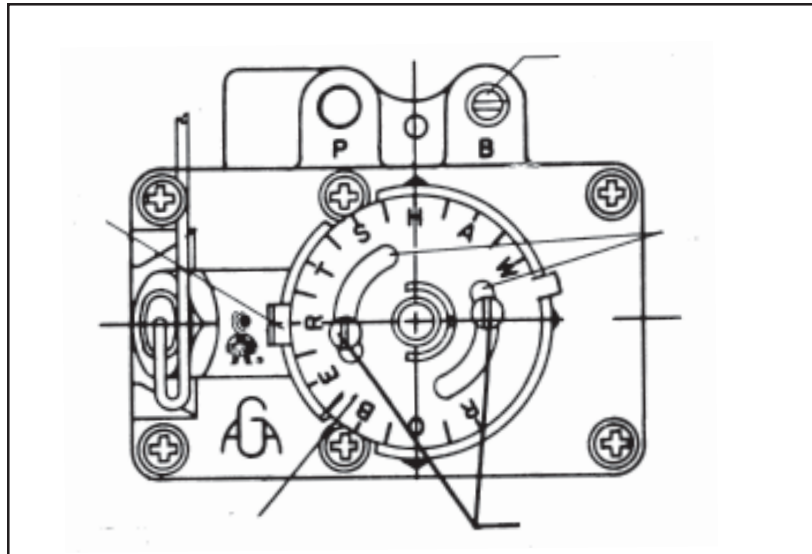

PROCEDURE:

1. Turn dial to 300 ° F.
2. Light main burner.
3. After oven temperature rises and remains constant turn dial back to low. This closes main valve and permits only the bypass gas to the burner.
4. Remove dial.
5. With a screwdriver, turn the bypass flame adjuster screw counterclockwise to increase the bypass flame or clockwise to decrease it until the flame over the entire burner is approximately 1/8" high. Replace dial.

THERMOSTAT CALIBRATION CHECK: - 136 SERIES

1. Place the thermocouple of test instrument or thermometer in the middle of the oven.
2. Light the main burner.
3. Turn dial so 400 lines up with the indicator mark on dial stop.
4. Allow the oven to heat until flame cuts down to bypass. After sufficient time, check temperature. If the temperature does not read within 15 degrees of the dial setting, recalibrate as follows:
 - A. Pull dial straight off without turning.
 - B. Hold calibration plate and loosen the two calibration lock screws until the plate can be moved independently of the control.
 - C. Turn calibration plate so that the instrument or thermometer reading is in line with the indicator mark. Hold plate and tighten screws firmly. On controls where the plate has no temperature markings use a chart to determine the temperature degrees between letters. Turn the calibration plate counter-clockwise if the test reading is higher than the dial setting, or clockwise if the reading is lower than the dial setting.
 - D. Replace dial.

NOTE: If the above adjustment is prevented by the two loosened calibration lock screws being in contact with the ends of the screw clearance slots in the calibration plate, remove the screws and after turning the calibration plate to the proper location, reassemble screws in the other tapped holes designed for them.

| RECALIBRATION CHART | | |
|----------------------------|----------------------------------|-------------------------|
| Dial Range | Degrees F Between Letters | Calibration Mark |
| 200 to 500 | 50 Degrees | 400 ° |

OVEN THERMOSTAT - 124 SERIES

The Model BJ Robertshaw is a combination thermostat and gas valve. The gas is turned on and the temperature setting made by a single rotation of the dial. This valve automatically locks itself in the OFF position. To use, push dial inward, rotate counterclockwise to the desired temperature. To shut gas off, rotate clockwise to OFF position.

This thermostat is a precision instrument carefully made and properly calibrated (i.e. the dial is properly set) at the factory to control temperatures accurately. It should control temperatures for the proper cooking of food without recalibration. The calibration of this thermostat should not be changed until considerable experience with cooking results has definitely proved that the thermostat is not maintaining the proper temperature.

| |
|---|
| <p>CAUTION THE RECALIBRATION SHOULD NOT BE MADE UNTIL THE BYPASS (MINIMUM BURNER) FLAME HAS BEEN PROPERLY ADJUSTED.</p> |
|---|

SERVICE

ADJUSTMENT OF BYPASS (MINIMUM BURNER) - 124 SERIES

This is the flame that must be maintained on the burners when the oven has come up to the temperature set on the dial. Enough gas must be bypassed by the control to keep the entire burner lit. The thermostat regulates the flame from high to low in accordance with the oven temperature and will automatically turn down to this bypass flame when the temperatures set on the dial is attained in the oven.

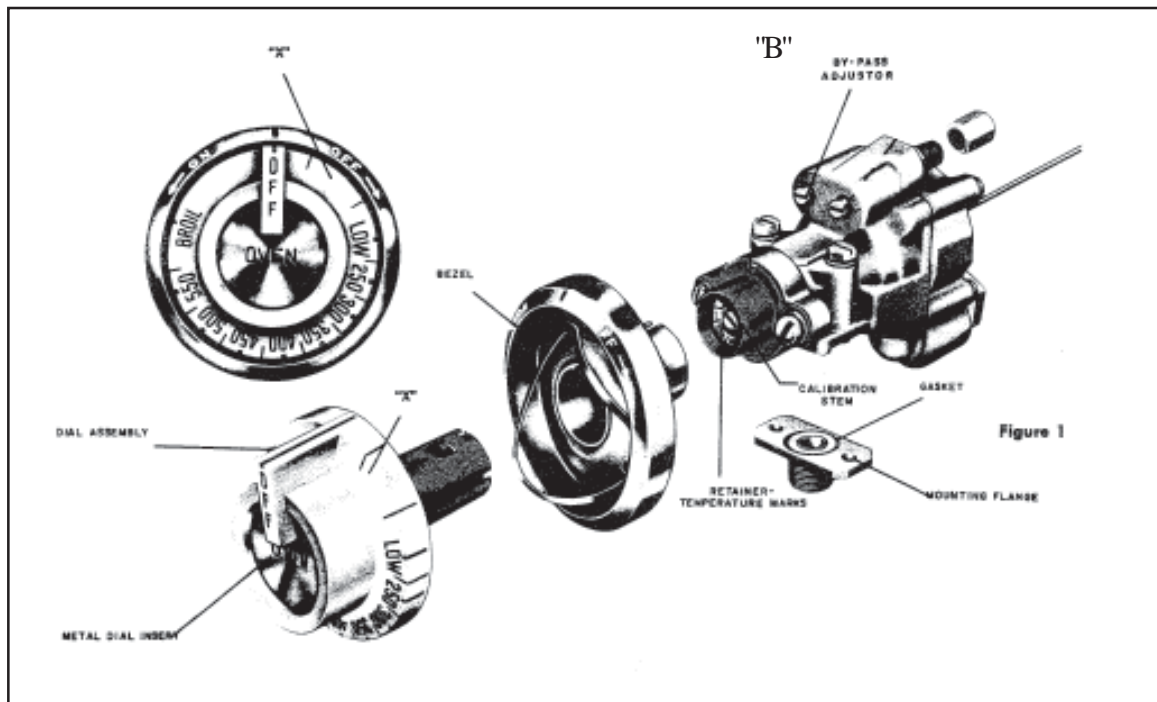

THE BYPASS MUST BE SET CAREFULLY AND ACCURATELY AS FOLLOWS:

1. Light burners and turn Dial (A) counterclockwise and to a point midway between the "Gas On" mark and next graduation to the right of it (shown by "X"). If the burner goes out entirely, the bypass is closed.
2. Slip off Dial (A). Remove valve panel from front of range.
3. With a screwdriver, turn Bypass Adjuster (B). Turning it out counterclockwise increases the bypass flame; turning it in clockwise decreases the bypass flame. Adjust until there is a flame approximately 1/8" high over the entire burner.
4. Replace dial, rotating dial clockwise until it snaps into its original position
5. Reinstall valve panel on front of range.

OVEN THERMOSTAT CALIBRATION CHECK: - 124 SERIES

The oven temperature should be checked or recalibrated with oven hot. NOTE: see "Adjustment of Bypass (Minimum Burner) Flame" above before recalibrating this thermostat.

HOT CHECK METHOD - 136 SERIES

1. Place the reliable thermometer in center of oven.
2. Set Dial (A) at 350 ° F.
3. Wait until temperature rises and remains constant.
4. If dial does not agree with thermometer readings, slip off Dial (A) and push out metal insert.
5. Replace dial, turn to 350 ° F mark.
6. Hold dial firmly, insert screwdriver through center of dial and push calibration stem (C) inward. DO NOT TURN THIS STEM.
7. While holding calibration stem (C) in firmly with screwdriver, turn dial until it is set at the actual oven temperature as shown by your test instrument or thermometer. Release pressure on calibration stem. Replace dial insert.

OPERATIONAL DIFFICULTIES & PROBABLE CAUSES

OVEN PILOT BURNER GOES OUT:

1. Gas shut off.
2. Poor draft in flue snuffs out flame.
3. Too much draft pulls flame away from thermocouple.
4. Pilot flame too low.
5. Thermocouple defective.
6. Thermocouple connection on safety pilot loose.
7. Pilot orifice dirty.
8. Safety pilot valve defective.
9. Gas leak at pilot orifice fitting.
10. Restricted or plugged vent on gas pressure regulator.

OVEN BURNER FAILS TO COME ON (PILOT ON):

1. Burner valve off.
2. Burner orifice plugged.
3. Thermostat out of calibration.
4. Minimum flame adjustment closed and thermostat setting too low.

SERVICE

OVEN TEMPERATURE HIGHER THAN DIAL SETTING:

1. Oven thermostat out of calibration.
2. Minimum flame too high. (Do not lower under 1/8").
3. Broken capillary tube on thermostat.
4. Dirt under thermostat valve seat.

Orifice Size Chart Drill Size

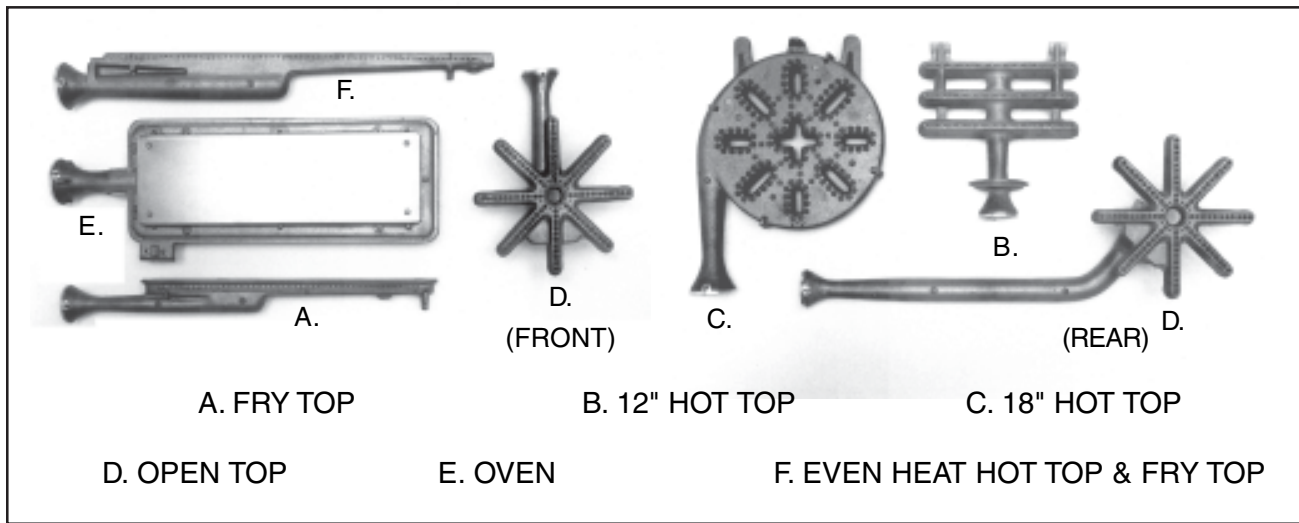

| Type of Burner | A | B | C | D Open Top 20,000 | D Open Top 30,000 | D 1/2 Hot Top | | E | | | A 124 | F |
|----------------------|------|------|------|-------------------------|-------------------------|------------------|------|-----|------|--------|----------|------|
| | | | | | | Front | Rear | 136 | V136 | 136XLB | | |
| Natural Gas 4.0" WC | 50 | 46 | 35 | 45 | 37 | 45 | 50 | 32 | 31 | ---- | ---- | 45 |
| Natural Gas 6.0" WC | ---- | ---- | ---- | 48 | 42 | 48 | 52 | 37 | 36 | 32 | 48 | ---- |
| Propane Gas 10.0" WC | 56 | 55 | 50 | 55 | ---- | 55 | 56 | 49 | 47 | 51 | 55 | 55 |

Montague 124 & 136 Series Heavy Duty Range Parts List

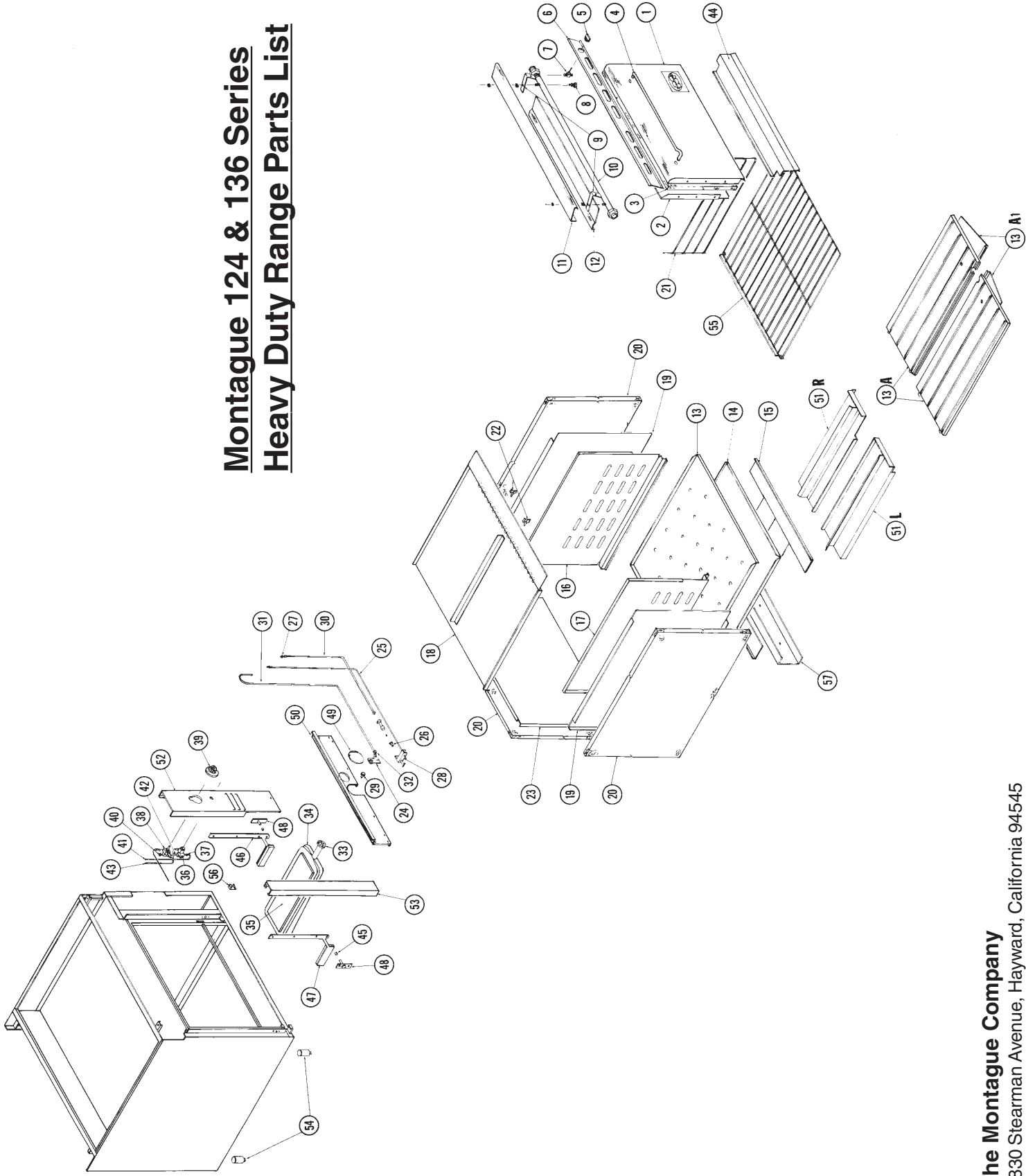

124 & 136XLB Series Only

| Item .. | Part # | Description | Item ... | Part # | Description |
|---------|--------------|---|----------|--------------|---|
| 1 | 8955-9 | Door Panel , Ext. - ptd (with nameplate) | 1 | 31081-6 | Door Panel, Ext. - S/S; 136XLB |
| 1 | 7644-9 | Door Panel, Ext. - S/S (with nameplate) | 1 | 31679-2 | Door Panel, Ext. - S/S; 124 Series (w/o nameplate) |
| 1 | 6134-4 | Door Panel, Ext. - ptd (with embossed "M") | 2 | 32536-8 | Door Panel, Int. - Porcelain; 124 Series |
| 1 | 6135-2 | Door Panel, Ext. - S/S (with embossed "M") | 2 | 31680-6 | Door Panel, Int. - Opt. S/S; 124 Series |
| 2 | 1548-2 | Door Panel, Int., (prior 8/84) | 2 | 32611-9 | Door Panel, Int. - Porcelain; 136 XLB |
| 2 | 2428-7 | Door Panel, Int., (post 8/84) | 2 | 31067-0 | Door Panel, Ext. - S/S; Opt. 136XLB |
| 3 | 1424-9 | Insulation, Door | 3 | 07631-7 | Insulation, Door - 124 Series |
| 4 | 3173-9 | Handle, Door | 3 | 32612-7 | Insulation, Door - 136XLB |
| 5 | 2004-4 | Handle, Main Oven Valve | | 32623-2 | Door Assembly - 136XLB (w/o handle) Porcelain |
| 6 | 3566-1 | Valve Panel - 36", S/S (specify width) | | 32522-8 | Door Assembly - 136XLB (w/o handle) S/S |
| 6 | 4576-4 | Valve Panel - 34", S/S (frytop models only) | | 32738-7 | Door Assembly - 124 Series (w/o handle) |
| 7 | 1056-1 | Valve, Oven - 1/4" NPTM x 7/16"cc (new style) | 4 | 11805-2 | Handle, Door - 124 Series |
| 7 | 4490-3 | Valve, Oven - 9/16"-27 x 7/16"cc (old style) | 6 | 31686-5 | Valve Panel - 24" S/S; 124 Series |
| 8 | 1288-2 | Pilot Fitting - 1/8" NPT x 1/4" tube | 8 | 32739-5 | Valve, Pilot Shutoff - 90°; 1/8NPTM x 1/4cc; 124 Series |
| 9 | 6137-9 | Bracket, Valve Panel | 10 | 32691-7 | Manifold - 124 Series (order by length & model) |
| 10 | 1073-1 | Manifold - 36", Comb. (order by length & model) | 11 | 06913-2 | Guard Rail - S/S; 124 Series (w/o hardware) |
| 11 | 6860-8 | Guard Rail - 36", S/S (post 1/85-consult factory) | 12 | 32585-6 | Manifold Drip Shield Assy. - 124-5,-559 (specify model) |
| 12 | 4285-4 | Manifold Drip Shield (specify length) | 13 | 32539-2 | Oven Bottom - Porcelain; 124 Series |
| 13 | 1547-4 | Oven Bottom - Porcelain (change #17) | 13 | 31684-9 | Oven Bottom - Opt. S/S; 124 Series |
| 13 | 9051-4 | Oven Bottom - Porcelain (change #18) | 15 | 32630-5 | Burner Baffle - S/S; 124 Series |
| 13A | 4387-7 | Oven Bottom - Cast Iron (sold as pair) | 16 | 32600-3 | Side Liner, Oven Rt - Porcelain; 136XLB |
| 13A1 | 7987-1 | Heat Deflector for 13A Bottom | 16 | 32527-9 | Side Liner, Oven Rt - S/S 136XLB |
| 14 | 4601-9 | Heat Deflector | 17 | 32599-6 | Side Liner, Oven Lt - Porcelain; 136XLB |
| 15 | 6593-5 | Burner Baffle, S/S | 17 | 32526-0 | Side Liner, Oven Lt - S/S 136XLB |
| 16 | 9044-1 | Side Liner, Oven - Right (change #18) | 18 | 32605-4 | Top Liner, Oven - Porcelain; 136XLB |
| 17 | 9043-3 | Side Liner, Oven - Left (change #18) | 18 | 32528-7 | Top Liner, Oven - S/S; 136XLB |
| 18 | 1538-5 | Top Liner, Oven - Porcelain | 18 | 32545-7 | Top Liner, Oven - Porcelain; 124 Series |
| 19 | 12874-0 | Interior Liner - Left & Right (with stiffener) | 18 | 32703-4 | Top Liner, Oven - S/S; 124 Series |
| 20 | 12894-5 | Insulation, Oven - Left, Right & Rear | 19 | 31079-4 | Interior Liner, Lt/Rt; 136XLB |
| 21 | 7223-0 | Rack Guide - Left or Right | | 32463-9 | Spacer |
| 22 | 1942-9 | Clip, Thermostat Bulb | 19 | 32709-3 | Liner Spacer - S/S; 124 Series |
| 23 | 1536-9 | Rear Liner, Oven - Porcelain | 21 | 32530-9 | Rack Guide - Lt/Rt |
| 24 | 6149-2 | Bracket, Orifice Fitting - Oven | 23 | 32608-9 | Rear Liner, Oven - Porcelain; 136XLB |
| 25 | 1013-8 | Thermocouple Please Order By# and Des. | 23 | 31072-7 | Rear Liner, Oven - S/S; 136XLB |
| 26 | 2190-3 | Orifice, Oven Pilot (Nat. Gas) | 23 | 32542-2 | Rear Liner, Oven - Porcelain; 124 Series |
| 26 | 2191-1 | Orifice, Oven Pilot (LP Gas) | 23 | 31685-7 | Rear Liner, Oven - Opt. S/S; 124 Series |
| 27 | 6155-7 | Compression Nut & Ferrel - 1/4" tube | 29 | 02572-0 | Orifice, Main Burner - 136XLB Oven (Natural Gas) |
| 28 | 1017-0 | Pilot Burner (Nat. Gas) | 29 | 02257-0 | Orifice, Main Burner - 136XLB Oven (Propane Gas) |
| 28 | 1018-9 | Pilot Burner (LP Gas) | 29 | 06381-9 | Orifice, Main Burner - 124 Series Oven (Natural Gas) |
| 29 | 6150-6 | Orifice, Main Burner (Nat. Gas) | 29 | 02138-5 | Orifice, Main Burner - 124 Series Oven (Propane Gas) |
| 29 | 6151-4 | Orifice, Main Burner (LP Gas) | 30 | 01225-4 | Tubing - 1/4"; 124 Series (safety valve to pilot) |
| 30 | 3604-8 | Tubing - 1/4" (safety valve to pilot burner) | 31 | 15909-3 | Tubing - 3/8"; 124 Series (thermostat to safety valve) |
| 31 | 3602-1 | Tubing - 7/16" (thermostat to burner-42") | 32 | 02412-0 | Elbow Assembly w/ Orifice - 136XLB Oven (Natural Gas) |
| 32 | 6152-2 | Elbow Assembly w/Orifice (Nat. Gas) | 32 | 32723-9 | Elbow Assembly w/ Orifice - 136XLB Oven (Propane Gas) |
| 32 | 6153-0 | Elbow Assembly w/Orifice (LP Gas) | 32 | 14610-2 | Elbow Assembly w/ Orifice - 124 Series (Natural Gas) |
| 33 | 2037-0 | Air Mixer, Oven Burner | 32 | 02586-0 | Elbow Assembly w/ Orifice - 124 Series (Propane Gas) |
| 34 | 6350-9 | Burner, Oven (new style less pilot mount) | 34 | 03361-8 | Burner, Oven - 124 Series |
| 35 | 9518-4 | Baffle, Main Oven Burner | 36 | 29766-6 | Safety Valve Assembly - 124 Series |
| 36 | 34604-7 | Safety Valve, Pilot | 38 | 11810-9 | Thermostat, BJWA - 124 Series |
| 37 | 1277-7 | Fitting - 1/4" tube (tapered, compression) | 39 | 32706-9 | Dial, Oven Thermostat - BJWA; 124 Series |
| 38 | 1061-8 | Thermostat, FDTO (with dial 500) | 40 | 01281-5 | Fitting - 3/8" NPTM x 3/8" cc - 45°; 124 Series |
| 39 | 1977-1 | Dial, FDTO Thermostat | 43 | 01229-7 | Tubing - 1/4"; 124 Series (pilot shutoff valve to safety valve) |
| 40 | 1287-4 | Fitting 3/8" NPT x 7/16" tube | 44 | 28584-6 | Panel, Firebox - S/S (P/N 3524-6 with hinge) |
| 41 | 3600-5 | Tubing 7/16" (main valve to safety—change #8) | 44 | 32657-7 | Panel, Firebox - S/S; 124 Series (includes hinge) |
| 42 | 1150-9 | Nipple, Pipe - 3/8" x 2" | 46 | 32523-6 | Door Trunnion, Lt - 136XLB |
| 43 | 3605-6 | Tubing 1/4" (manifold to safety valve) | 46 | 07628-7 | Door Trunnion, Right - 124 Series |
| 44 | 3459-2 | Panel, Firebox - Ptd (change #14-clip style) | 46 | 32524-4 | Door Trunnion, Rt - 136XLB |
| 44 | 3524-6 | Panel, Firebox - S/S (change #14-clip style) | 47 | 07627-9 | Door Trunnion, Left - 124 Series |
| 45 | 1260-2 | Spacer, Door Pin | 49 | 11854-0 | Door, Pilot Access - 124 Series |
| 46 | 6077-1 | Door Trunnion - Right | 50 | 11856-7 | Burner Compartment Front Assembly - 124 Series |
| 47 | 6979-8 | Door Trunnion - Left | 51L | 14202-6 | Baffle, Air - Left; 124 Series |
| 48 | 3393-6 | Pin, Oven Door | 51R | 14135-6 | Baffle, Air - Right; 124 Series |
| 49 | 4274-9 | Door, Pilot Access | 52 | 32748-4 | Panel, Right Front - 124 Series |
| 50 | 4275-7 | Burner Compartment Front | 52 | 32389-6 | Panel, Right Front - 136XLB |
| 51L | 6346-0 | Baffle, Air - Left | 53 | 32747-6 | Panel, Left Front - 124 Series |
| 51R | 6348-7 | Baffle, Air - Right | 53 | 32388-8 | Panel, Left Front - 136XLB |
| 52 | 4645-0 | Panel, Right Front Control - Ptd (after 9/70) | 55 | 11615-7 | Rack, Oven - 124 Series; 25-5/8" x 15-9/16" |
| 52 | 4610-8 | Panel, Right Front Control - S/S (after 9/70) | 57 | 31691-1 | Support, Channel - 124 Series |
| 53 | 4288-9 | Panel, Left Front Control - Ptd (after 9/70) | | | |
| 53 | 4286-2 | Panel, Left Front Control - S/S (after 9/70) | | | |
| 54 | 3468-1 | Leg - 6" Ptd | | | |
| 54 | 3467-3 | Leg - 6" S/S | | | |
| 55 | 9005-0 | Rack, Oven - 25-5/8" x 26" | | | |
| 56 | 6926-4 | Catch, Spring (female) | | | |
| 57 | 7584-1 | Support, Channel | | | |

Montague Heavy Duty Gas Range - Open Top Section

12" and 18" Wide - 1/2 Open Top 1/2 Hot Top - 12" Hot Top - 12" Wide

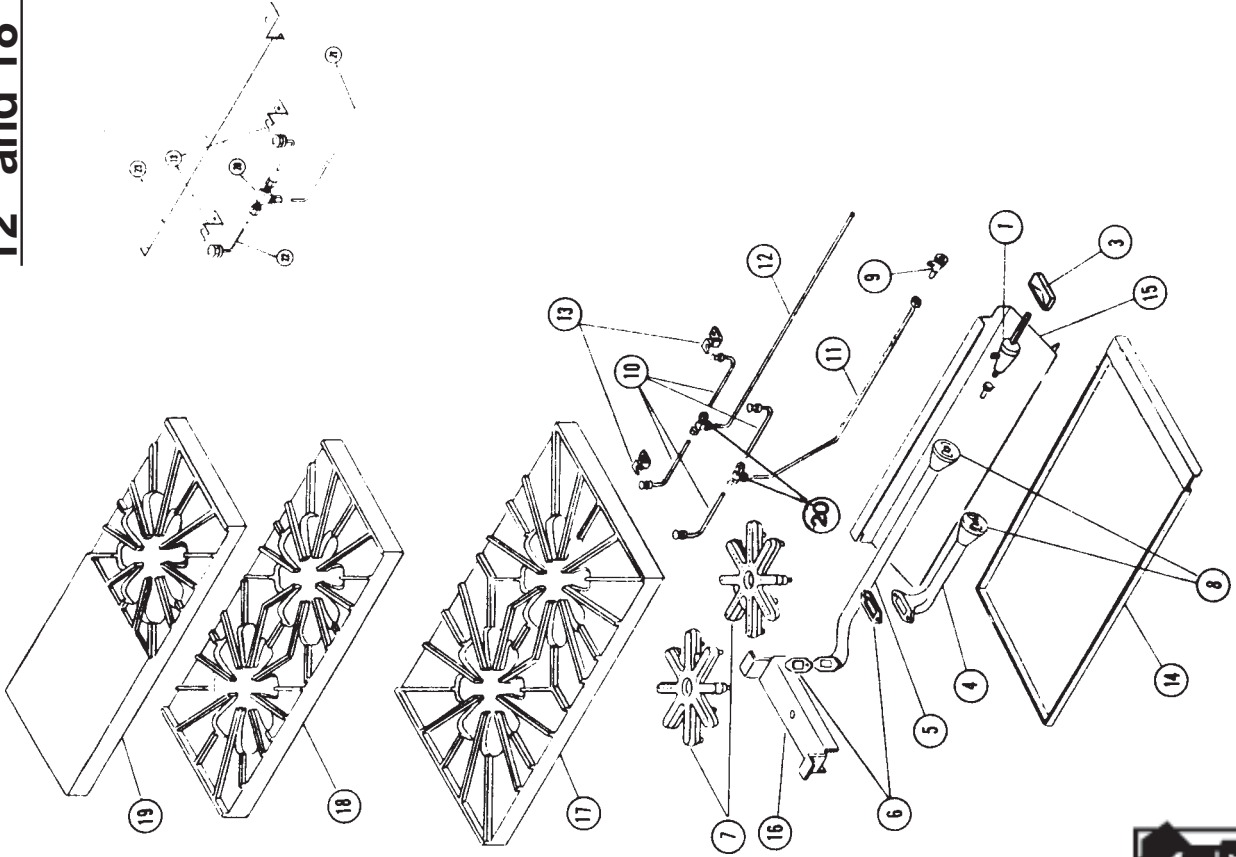

| Item | Part # | Description |
|-------------|---------|--|
| 1 | 04330-3 | Valve, Top Burner (Nat) Except 1/2 Hot Top |
| 1 | 01003-0 | Valve, Top Burner (LP) Except 1/2 Hot Top |
| 1 | 02101-1 | Valve, Top Burner (Nat) 1/2 Hot Top Only |
| 1 | 01002-2 | Valve, Top Burner (LP) 1/2 Hot Top Only |
| 3 | 02002-8 | Handle, Valve w/Set Screw |
| 4 | 03348-0 | Venturi, Front Burner |
| 4, 6, 7, 8 | 03347-2 | Burner, Front - Complete |
| 5 | 03350-2 | Venturi, Rear Burner (Left swing shown) |
| 5, 6, 7, 8 | 03349-9 | Burner, Rear Left - Complete |
| 5A, 6, 7, 8 | 03351-0 | Burner, Rear Right Complete (not shown) |
| 6 | 02115-6 | Gasket |
| 7 | 03346-4 | Burner Head Only |
| 8 | 02038-9 | Air Mixer |
| 9 | 01055-3 | Pilot Valve |
| 10 | 03583-1 | Lighter, Pilot |
| 10, 11, 20 | 03431-2 | Pilot Kit - 12" Section (Less Valve) |
| 10, 12, 20 | 03430-4 | Pilot Kit - 18" Section (Less Valve) |
| 20, 21, 22 | 07142-0 | Pilot Kit - 12" -59 Section (Less Valve) |
| 13 | 01518-0 | Pilot Bracket |
| 14 | 03379-0 | Drip Tray - 36" Unit |
| 14 | 03378-2 | Drip Tray - 24" Unit |
| 14 | 03377-4 | Drip Tray - 18" & 12" Unit |
| 15 | 03380-4 | Drip Tray Guide |
| 16 | 03498-3 | Support, Open Burner 36" Unit |
| 16 | 03530-0 | Support, Open Burner 24" Unit |
| 16 | 03531-9 | Support, Open Burner 18" Unit |
| 16 | 03532-7 | Support, Open Burner 12" Unit |
| 17 | 03480-0 | 18" Open Top |
| 18 | 03580-7 | 12" Open Top |
| 19 | 03482-7 | 12" Combination -59 Top (1/2 Hot Top) |
| 22 | 06232-4 | Lighter, Pilot |
| 23 | 03556-4 | Bracket, Pilot MTG (-59 Top) |



The Montague Company
 1830 Stearman Avenue, Hayward, California 94545

Montague Heavy Duty Gas Range Hot Top Section - 12" Wide Front Fired

| Item | Part # | Description |
|------|---------|-----------------------------------|
| 1 | 02406-6 | Valve, Top Burner - Nat |
| 1 | 01003-0 | Valve, Top Burner - LP |
| 3 | 02002-8 | Handle, Valve w/Set Screws |
| 4 | 01055-3 | Valve, Pilot |
| 5 | 03421-5 | Pilot Lighter |
| 6 | 04299-4 | Burner Support W/Insulation - 36" |
| 6 | 04284-6 | Burner Support W/Insulation - 24" |
| 6 | 04283-8 | Burner Support W/Insulation - 12" |
| 7 | — | Insulation Pad |
| 9 | 03353-7 | Burner, 12" Hot Top |
| 10 | 02038-9 | Air Mixer |
| 11 | 01635-7 | Baffle, Burners - Cast Iron |
| 12 | — | Manifold Shield W/Stops |
| 13 | 03560-2 | Insulated Side Shield |
| 14 | 01738-8 | Hot Top - 12" Section |

Montague Heavy Duty Gas Range Hot Top Section - Even Heat 12" and 18" Wide

| Item | Part # | Description |
|------|---------|--------------------------------------|
| 1 | 04330-3 | Valve, Top Burner Nat |
| 1 | 01003-0 | Valve, Top Burner LP |
| 3 | 02002-8 | Handle, Valve w/Set Screw |
| 4 | 01055-3 | Valve, Pilot |
| 5 | 03416-9 | Pilot Lighter |
| 6 | 03362-6 | Burner, Even Heat Hot Top - Complete |
| 7 | 02037-0 | Air Mixer |
| 8 | 10628-3 | Support, Burner 36" |
| 8 | 04468-7 | Support, Burner 24" |
| 8 | 10629-1 | Support, Burner 18" |
| 8 | 07133-1 | Support, Burner 12" |
| 9 | 03560-2 | Baffle - Heat assy. |
| 10 | 03533-5 | Baffle - Air Assy. 3-1/8" Wide |
| 10 | 03538-6 | Baffle - Air Assy. 9-1/4" Wide |
| 11 | 01738-8 | Hot Top, 12" Section |
| 12 | 01741-8 | Hot Top, 18" Section |

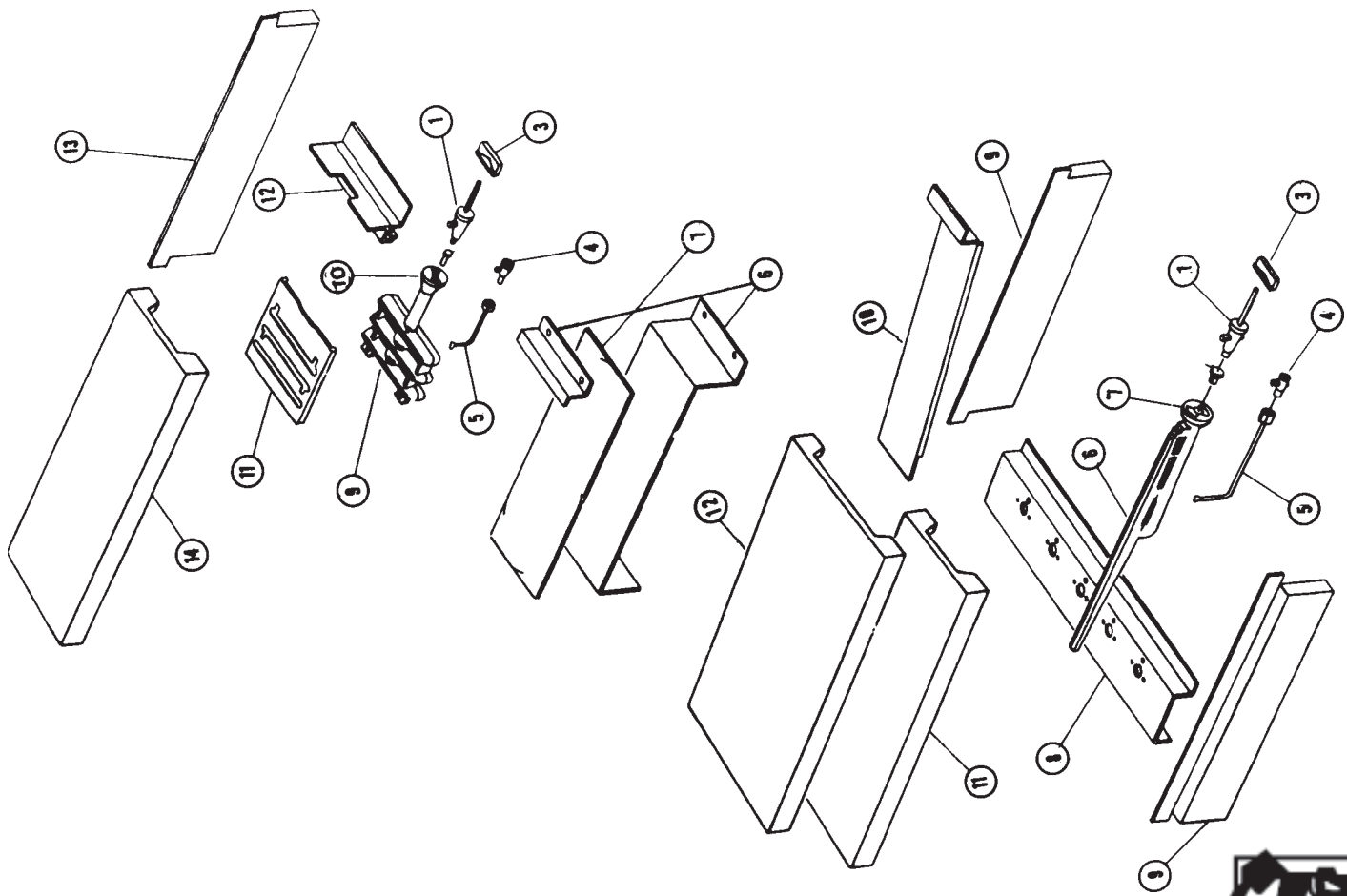

The Montague Company
1830 Stearman Avenue, Hayward, California 94545



Montague Heavy Duty Gas Range Hot Top Section - 12" Wide Front Fired

| Item | Part # | Description |
|------|---------|---|
| 1 | 02408-2 | Valve, Top Burner - Nat. |
| 1 | 02405-8 | Valve, Top Burner - LP |
| 3 | 02002-8 | Handle, Valve w/Set Screw |
| 4 | 01055-3 | Valve, Pilot |
| 5 | 03419-3 | Pilot Lighter |
| 6 | 04412-1 | Baffle-Air Assy - 36" Unit |
| 6 | 04414-8 | Baffle-Air Assy - 18" Unit |
| 7 | 04281-1 | Burner & Brick Support - 36" Unit |
| 7 | 04298-6 | Burner & Brick Support - 18" Unit |
| 8 | 01764-7 | Brick (1-1/4 x 8 x 13) |
| 9 | 03356-1 | Burner, 18" Hot Top - Complete (Right Swing) |
| 9A | 03355-3 | Burner, 18" Hot Top - Complete (Left Swing) Not Shown |
| 10 | 02037-0 | Air Mixer |
| 11 | 03560-2 | Insulated Side Shield |
| 12 | 01743-4 | Hot Top - 18" W/Ring & Cover |
| 13 | 01745-0 | Ring |
| 14 | 01747-7 | Cover |
| 15 | 01741-8 | Hot Top - 18" - Solid |

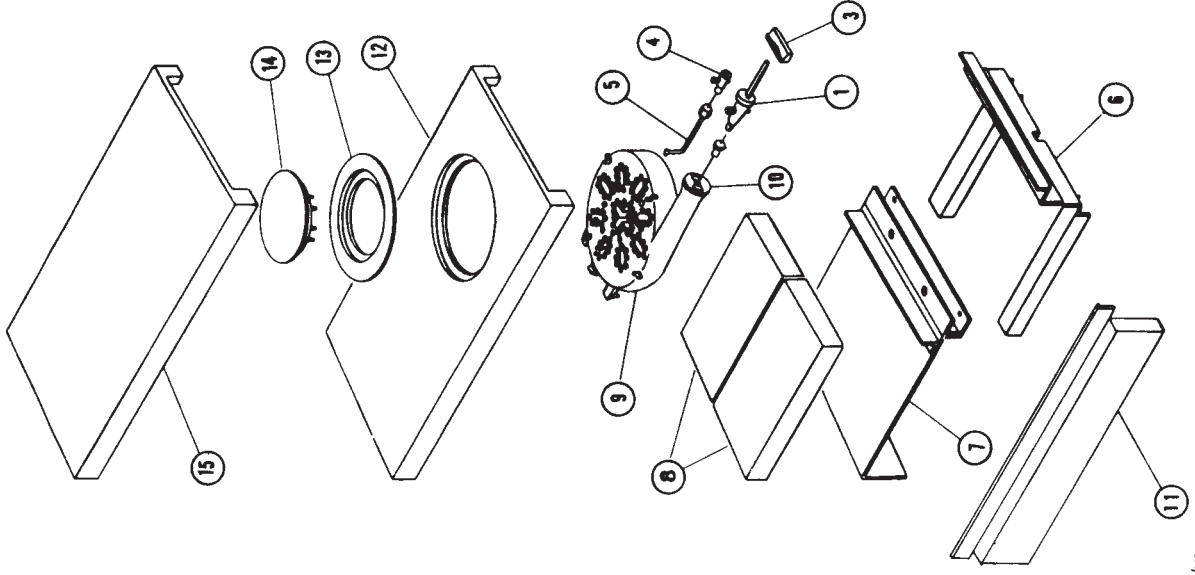

(2) [12/96 thru 2/00] - Integral Thermostat Safety Valve
(3) [3/00 thru present] - Separate Thermostat and Safety Valve



WARNING

If not installed, operated and maintained in accordance with the manufacturer's instructions, this product could expose you to substances in fuel or in fuel combustion which can cause death or serious illness and which are known to the State of California to cause cancer, birth defects or other reproductive harm.

The State of California enacted the California Safe Drinking Water and Toxic Enforcement Act of 1986, (Prop. 65), which "prohibits any person in the course of doing business from knowingly and intentionally exposing any individual to a chemical known to the State of California to cause cancer or reproductive toxicity without first giving clear and reasonable warning to such individuals." The Governor's Scientific Advisory Panel added carbon monoxide to the list of hazardous chemicals known to cause reproductive harm.

In order to establish full compliance with Proposition 65, we attached a yellow warning label to each gas fired unit manufactured by the Montague Company.

Carbon monoxide would not be present in concentrations that would pose a "significant risk" to the consumer when the equipment is installed, operated and maintained as follows:

1. Installed in accordance with all local codes, or in the absence of local codes, with the current National Fuel Gas Code Z223.1.
2. Installed under a properly designed and operating exhaust hood.
3. Connected to the type of gas for which the unit is equipped.
4. Proper appliance pressure regulator installed on the gas supply line and adjusted for the manifold pressure marked on the rating plate.
5. Adequate air supply to the unit.
6. The equipment is operated in the manner intended using the proper utensil for that type of appliance.
7. Keep the equipment clean and have it checked periodically.
8. Burner air adjustments, mechanical maintenance and repairs should be performed by qualified service personnel.

If the equipment is not installed, operated and maintained in accordance with the above, concentrations of carbon monoxide in excess of the established limits could present in the kitchen environment.

ALL PERSONNEL IN THE WORKPLACE WHO MAY BE SUBJECT TO ANY EXPOSURE OF CARBON MONOXIDE MUST BE WARNED OF SUCH POSSIBLE EXPOSURE. THIS WARNING SHOULD BE CONVEYED IN A MANNER SO THAT IT IS CLEARLY UNDERSTOOD BY THE EMPLOYEE, AND THE EMPLOYEE SHOULD BE ASKED IF IN FACT HE OR SHE UNDERSTANDS THE CORRECT METHOD OF OPERATION OF THE EQUIPMENT AND THAT A RISK OF EXPOSURE EXISTS IF THE EQUIPMENT IS OPERATED IMPROPERLY.



THE MONTAGUE COMPANY

1830 Stearman Avenue, P.O. Box 4954, Hayward, CA 94540-4954

IMPORTANT

When ordering parts, to eliminate mistakes and facilitate delivery, always give the following information:

Serial No. _____

Model No. _____

Change No. _____

Name & No. of Part

| <u>Model No.</u> | <u>Change No.</u> | <u>Serial No.</u> | |
|----------------------|----------------------|----------------------|----------------------|
| <input type="text"/> | <input type="text"/> | <input type="text"/> | <input type="text"/> |

The Montague Company
1830 Stearman Avenue
P.O. Box 4954
Hayward, CA 94540-4954

(REV. C) P/N 4527-6 11/05