

INSTRUCTION MANUAL

MONTAGUE LEGEND

Gas Pizza Ovens

MODELS:

13P-1, 14P-1, 15P-1,
23P-2, 24P-2, 25P-2

These instructions should be read thoroughly before attempting installation.
Set up and installation should be performed by qualified installation personnel.

Keep area around appliances free and clear from combustibles.

PLEASE RETAIN THIS MANUAL
FOR FUTURE REFERENCE.



THE MONTAGUE COMPANY

1830 STEARMAN AVENUE, P.O. BOX 4954

HAYWARD, CA 94540-4954

TEL: 510/785-8822 FAX: 510/785-3342

IMPORTANT

WARNING:

Improper installation, adjustment, alteration, service or maintenance can cause property damage, injury or death. Read the operating and maintenance instructions thoroughly before installing or servicing this equipment.

FOR YOUR SAFETY:

Do not store or use gasoline or other flammable vapors and liquids in the vicinity of this or any other appliance.

INSTRUCTIONS TO BE FOLLOWED IN THE EVENT THE USER SMELLS GAS MUST BE POSTED IN A PROMINENT LOCATION. THIS INFORMATION MAY BE OBTAINED BY CONSULTING THE LOCAL GAS SUPPLIER.

SHIPPING DAMAGE CLAIM PROCEDURE

For your protection, please note that equipment in this shipment was carefully inspected and packed by skilled personnel before leaving the factory. The transportation company assumed full responsibility for safe delivery upon acceptance of this shipment.

If shipment arrives damaged:

1. **VISIBLE LOSS OR DAMAGE** - Be certain this is noted on freight bill or express receipt, and signed by person making delivery.
2. **FILE CLAIM FOR DAMAGES IMMEDIATELY** - Regardless of the extent of damage.
3. **CONCEALED LOSS OR DAMAGE** - If damage is unnoticed until merchandise is unpacked, notify transportation company or carrier immediately, and file "concealed damage" claim with them. This should be done within fifteen (15) days of date that delivery was made to you. Be sure to retain container for inspection.

We cannot assume responsibility for damage incurred in transit. We will, however, be glad to furnish you with necessary documents to support your claim.

INSTALLATION

Montague gas pizza ovens are manufactured for use with the type of gas supply indicated on the nameplate located behind the burner compartment door.

The pizza oven is produced with the best possible material and workmanship. PROPER INSTALLATION IS ESSENTIAL FOR SAFE AND EFFICIENT TROUBLE-FREE OPERATION.

THE INSTALLATION INSTRUCTIONS CONTAINED HEREIN ARE FOR THE USE OF QUALIFIED INSTALLATION AND SERVICE PERSONNEL ONLY. INSTALLATION OR SERVICE BY OTHER THAN QUALIFIED PERSONNEL MAY RESULT IN DAMAGE TO THE OVEN/OR INJURY TO THE OPERATOR.

Qualified installation personnel are individuals, a firm, corporation or company which either in person or through a representative are engaged in, and are responsible for:

The installation or replacement of gas piping or the connection, installation, repair or servicing of equipment, who is experienced in such work, familiar with all precautions required, and has complied with all requirements of state or local authorities having jurisdiction. Reference: National Fuel Gas Code Z223.1-1988, Section 1.4.

READ CAREFULLY AND FOLLOW THESE INSTRUCTIONS

THE OVEN MUST BE INSTALLED IN ACCORDANCE WITH LOCAL CODES, OR IN THE ABSENCE OF LOCAL CODES, WITH THE NATIONAL FUEL GAS CODE, ANSI Z223.1-1988, INCLUDING:

1. The appliance and its individual shutoff valve must be disconnected from the gas supply piping system during any pressure testing of that system at test pressures in excess of 1/2 psig. (3.45 kPa).
2. The appliance must be isolated from the gas supply piping system by closing its individual manual shutoff valve during any pressure testing of the gas supply piping system at test pressure equal to or less than 1/2 psig. (3.45 kPa).

PROVISIONS MUST BE MADE FOR ADEQUATE AIR SUPPLY TO THE UNIT.

INSTALLATION

VENTILATING HOOD

The ideal method of ventilation for a pizza oven is the use of a properly designed commercial ventilation hood. The hood should be connected to an adequate mechanical exhaust system.

Information on the construction and installation of ventilation hoods may be obtained from the "Standard for the Installation of Equipment for the Removal of Smoke and Grease Laden Vapors from Commercial Cooking Equipment", NFPA No. 96-1987, available from the National Fire Protection Association, Batterymarch Park, Quincy, MA 02269.

It is also necessary that sufficient room air ingress be allowed to compensate for the amount of air removed by the ventilation system. Otherwise, a subnormal atmospheric pressure will occur which may interfere with burner performance or may extinguish the pilot flame. In case of unsatisfactory oven performance, re-check performance with the exhaust fan turned "OFF".

DIRECT FLUE CONNECTION

If the oven(s) is connected to an outside flue, a drafthood P/N #03119-4 (PTD) or P/N #03132-1 (SS) must be used for the 13P-1 or 14P-1 series. For the 15P-1 series use P/N#28282-0 (PTD) or P/N#00000-0 (S/S). The draft hood attaches with screws over the flue opening and accepts an 8" diameter round vent pipe conformed to the oval flue collar. The flue vent pipe must extend above the roof surface adequately (reference the uniform mechanical code) and be in compliance with all local codes. The vent must be terminated in a listed vent cap.

<u>CLEARANCES</u>		
	COMBUSTIBLE CONSTRUCTION	NONCOMBUSTIBLE CONSTRUCTION
BACK	3"	3"
LEFT & RIGHT SIDE	1"	0"
SUITABLE FOR INSTALLATION ON COMBUSTIBLE FLOORS WITH MINIMUM 12" LEGS.		

CAUTION

DO NOT OBSTRUCT THE FLOW OF COMBUSTION AND VENTILATION AIR TO THE OVEN. KEEP THE APPLIANCE AREA FREE AND CLEAR FROM COMBUSTIBLES.

Provide adequate clearance for air openings into the combustion chamber.

Adequate clearances must be provided in the front and around the appliance for servicing and proper operation.

INSTALLATION

SETTING IN PLACE

Your Montague pizza oven has been shipped in sections for easy handling. Remove all packing material and accessories from oven interior. Sections may be turned on their sides to go through doorway after removal of tile, deck, deck supports and other loose parts. After all sections are at location, assemble and replace parts previously removed.

MODELS 13P-1, 14P-1 & 15P-1: Attach legs to unit with the screws that are provided. Set in final location.

MODELS 23P-2, 24P-2 & 25P-2: Attach legs to bottom section with the screws that are provided. Set bottom section in final location and place top section on bottom section. Attach trim strip across front between the two oven sections.

When oven is in permanent position, level entire unit by placing carpenter's level on oven bottom and adjust the foot on the bottom of each leg so that oven is level from front to back and side to side.

ASSEMBLY

Install door handle and secure with the screws that are provided. Install flue deflector or down draft diverter. Either a flue deflector or down draft diverter is shipped with every unit. The flue deflector is intended for use when oven is installed under a properly designed hood. When oven is directly connected to vent system, the down draft diverter must be used.

GAS CONNECTION

Before connecting oven to the gas supply line, be sure that all new piping has been cleaned and purged to prevent any foreign matter from being carried into the controls by the gas. In some cases, filters or drops are recommended. A separate Gas Shut-Off Valve must be installed adjacent to each oven and be located in an accessible area. It is important that adequately sized piping be run directly to point of connection at oven, with as few elbows and tees as possible. Consult local gas company for proper piping size and gas pressure.

Each oven is equipped with an appliance gas pressure regulator for use with natural gas. This gas pressure regulator is factory adjusted for the manifold pressure specified on the nameplate.

Connect each oven separately using 3/4" pipe or larger. If flexible or semiflexible connectors are used, it is recommended that an AGA listed flexible connector with an I.D. equal to 3/4" pipe be used. Avoid sharp bends or kinks.

Pipe joint compounds that are used should be resistant to the action of liquefied petroleum gases. **ALL PIPE JOINTS SHOULD BE TESTED FOR LEAKS USING A SOAP AND WATER SOLUTION BEFORE OPERATING THE OVEN. DO NOT USE AN OPEN FLAME.**

GAS PRESSURE REGULATOR

THIS PIZZA OVEN IS DESIGNED FOR USE WITH A GAS PRESSURE REGULATOR. THE REGULATOR SUPPLIED WITH THIS UNIT MUST BE USED. THIS UNIT IS EQUIPPED WITH FIXED ORIFICES.

FOR NATURAL GAS: This gas pressure regulator is factory adjusted for a 13P-1 at 4.4" W.C. ,14P-1 at 3.5" W.C. and 15P-1 at 3.1" W.C. manifold pressure. The rated inlet pressure to the regulator is 1/2 psig (3.45 kPa).

FOR PROPANE GAS: This gas pressure regulator is factory adjusted for a 13P-1, 14P-1 and 15P-1 at 10" W.C. manifold pressure. The rated inlet pressure to the regulator is 1/2 psig (3.45 kPa).

INSTALLATION

UPPER TILE LINING

Set tile in position. Tile must be tilted in order to pass between tile supports. Set tile in place on supports and slide toward rear of oven until all tiles are in position. (See Figure 2).

BAKING DECK

Solid / 2-piece or 3-piece deck

The solid deck will be shipped in place, if unit must be turned on its side, decks must be removed. To remove deck use two flat bladed screwdrivers to walk up the left front edge of the right deck. When deck is high enough grasp it firmly and pull over the top of the other deck. Remove from front of oven. (See Figure 3).

Tile deck

Set tile in place on supports and slide toward rear of oven until all tiles are in position. (See Figure 1 and 4).

LIGHTING INSTRUCTIONS

1. Turn oven valve clockwise to "OFF" position and wait five (5) minutes.
2. Open the burner compartment access panel, below oven door.
3. Press and hold red safety pilot in and apply lighted match to pilot burner. After pilot burner ignites, continue to hold red button depressed for 30-45 seconds or until pilot remains burning when button is released.
4. Close the burner compartment access panel.
5. Turn oven valve counter clockwise to "ON" position.
6. Set oven thermostat dial to desired temperature setting. In the event of pilot failure, turn oven valve to "OFF" position and repeat above instructions.
7. For complete shutdown, turn all valves to "OFF" position.

OVEN OPERATION

1. Before starting to bake, heat oven thoroughly. When burner shuts down to minimum flame, let oven stand for at least 10 minutes before using. This allows oven to become saturated with heat.
2. Open oven door as seldom as possible. Opening door frequently allows heat to escape resulting in a lower temperature near the door.
3. Do not allow drafts to blow on oven.

MODELS 13P-1 & 23P-2

ITEM #	PART #	STEEL			DEFLECTOR	ITEM #	SIZE
1	01763-9	1	1	1	2	1.	1-1/4" x 7" x 10-1/2"
2	03187-9					2.	1-1/4" x 7" x 7"
3	01766-3					3.	1-1/2" x 12" x 12"
4	15161-0	1	1	1	1	4.	1-1/2" x 7-1/2" x 12"
5	07565-5					5.	1-1/2" x 5-1/2" x 12"
6	15160-2					6.	1-1/2" x 6" x 7-1/2"
7	24572-0	1	1	1	1	7.	1-1/2" x ?? x ??

UPPER TILE LINER (FIGURE 2)

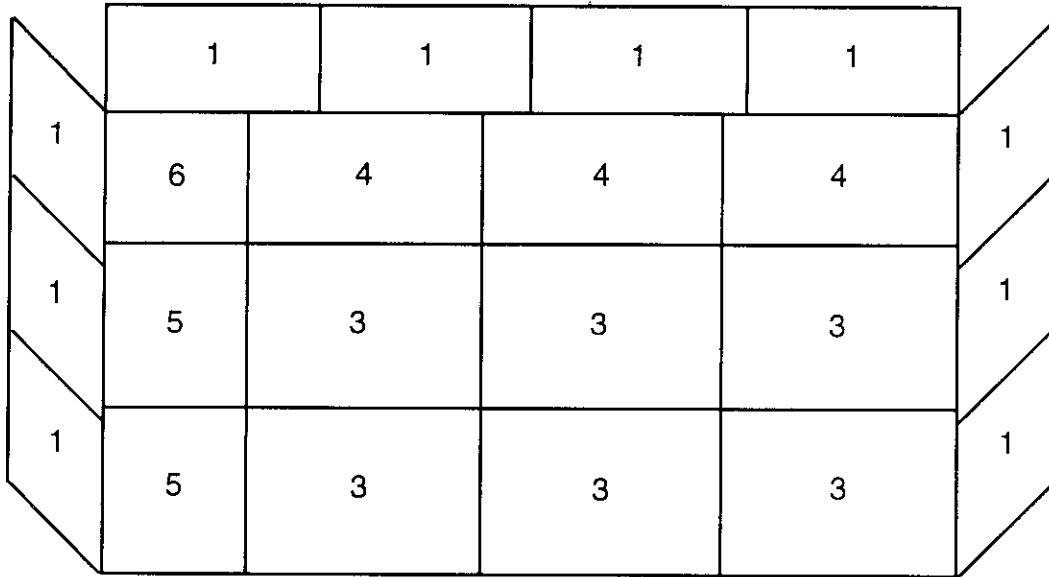

TILE DECK, SIDES & BACK (FIGURE 1 AND 4)

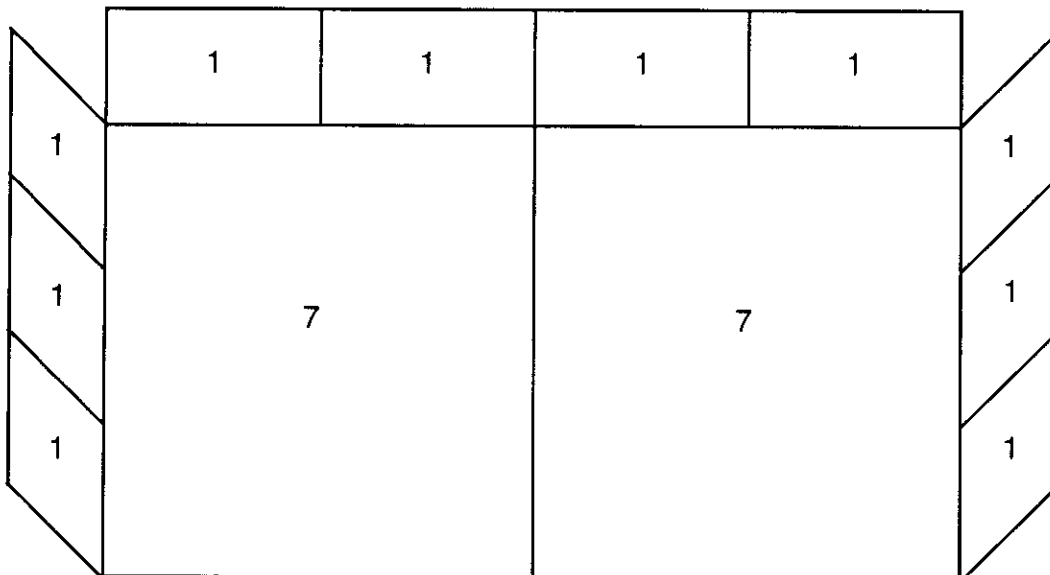

TWO PIECE DECK, SIDES & BACK (FIGURE 3)

MODELS 14P-1 & 24P-2

ITEM #	PART #
1	03188-7
2	03187-9
3	01763-9
4	01766-3
5	24571-2

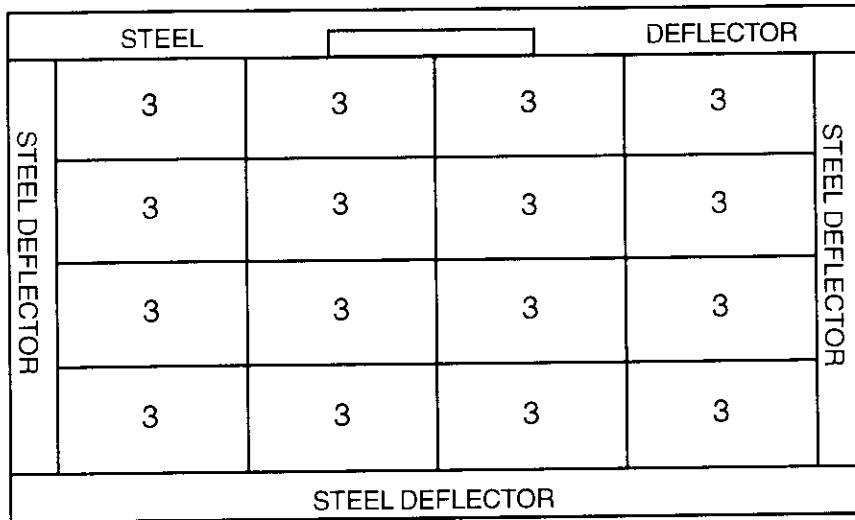

ITEM #	SIZE
1.	1-1/4" x 4-1/2" x 7"
2.	1-1/4" x 7" x 7"
3.	1-1/4" x 7" x 10-1/2"
4.	1-1/2" x 12" x 12"
5.	1-1/2" x 24" x 36"

UPPER TILE LINER (FIGURE 2)

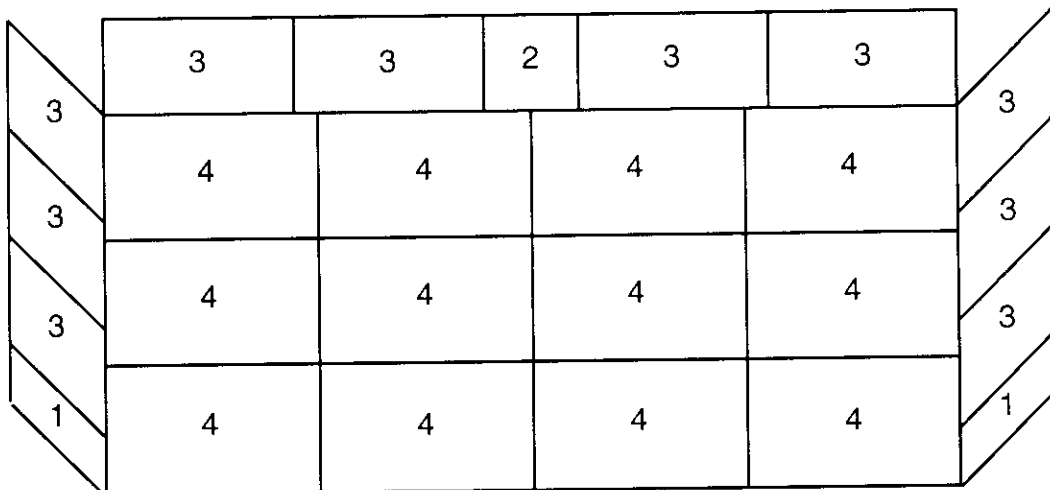

TILE DECK, SIDES & BACK (FIGURE 1 AND 4)

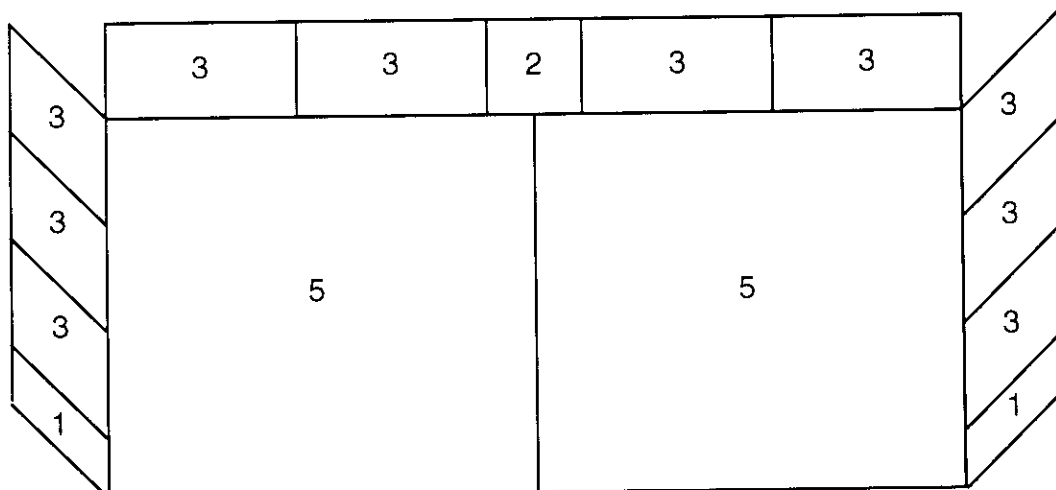

TWO PIECE DECK, SIDES & BACK (FIGURE 3)

MODELS 15P-1 & 25P-2

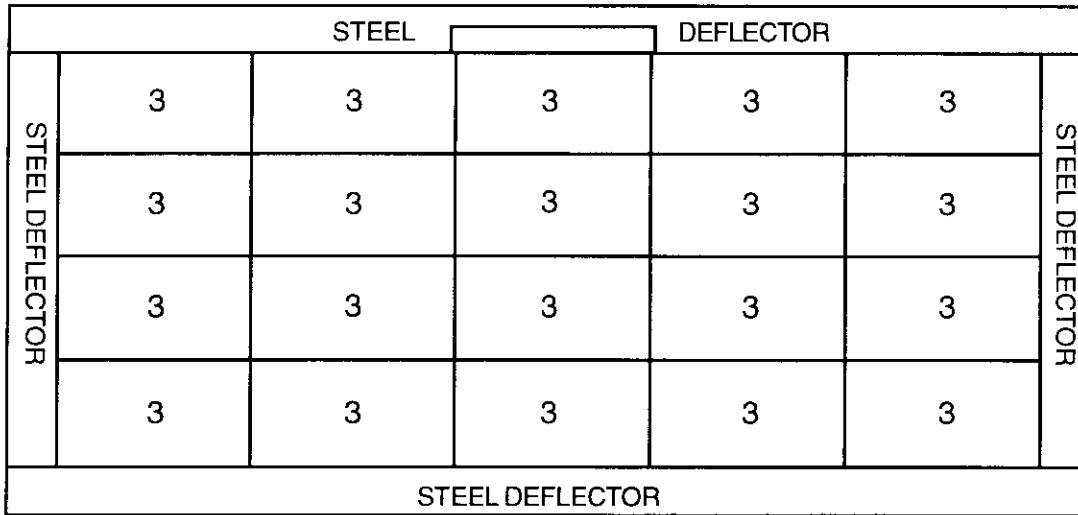

UPPER TILE LINER

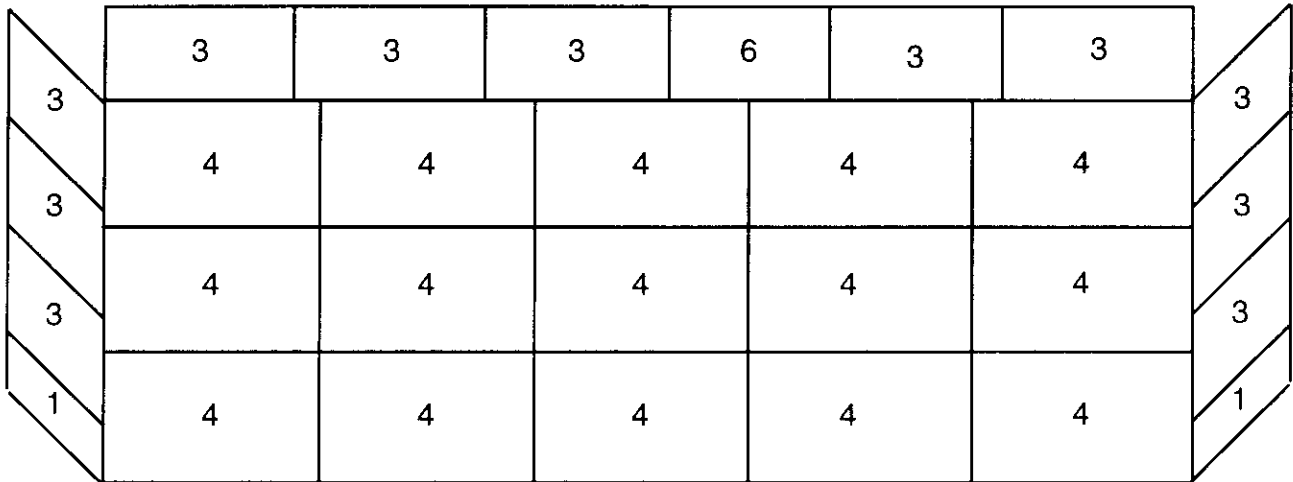

TILE DECK, SIDES & BACK

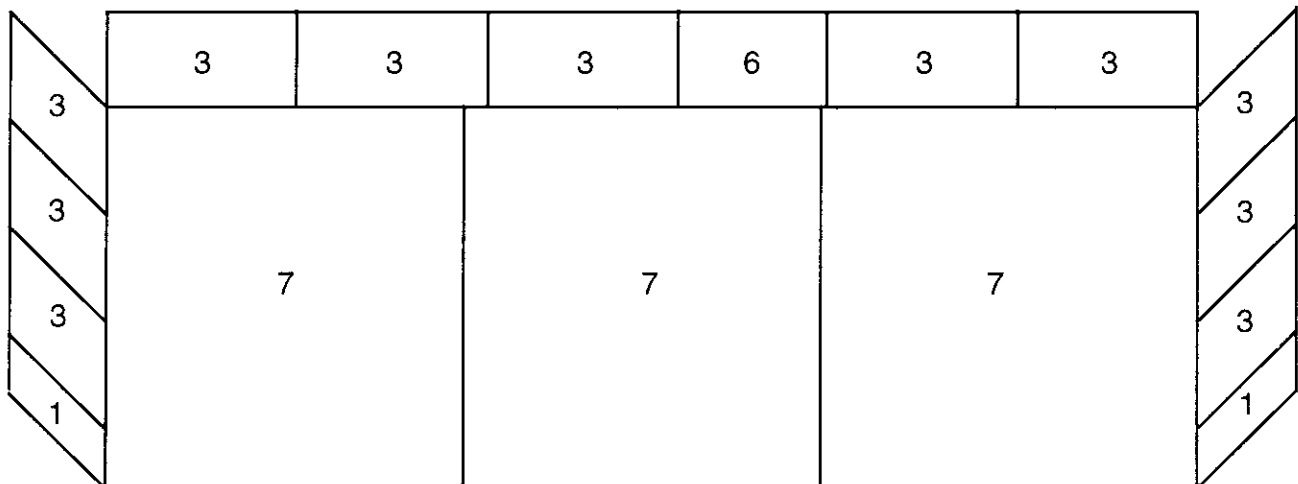

THREE PIECE DECK, SIDES & BACK

ITEM #	PART #	SIZE	ITEM #	PART #	SIZE
1	03188-7	1-1/4" x 4-1/2" x 7"	5	24571-2	1-1/2" x 24" x 36"
2	03187-9	1-1/4" x 7" x 7"	6	28280-4	1-1/4" x 7" x 8-3/4"
3	01763-9	1-1/4" x 7" x 10-1/2"	7	28279-0	1-1/2" x 20" x 36"
4	01766-3	1-1/2" x 12" x 12"			

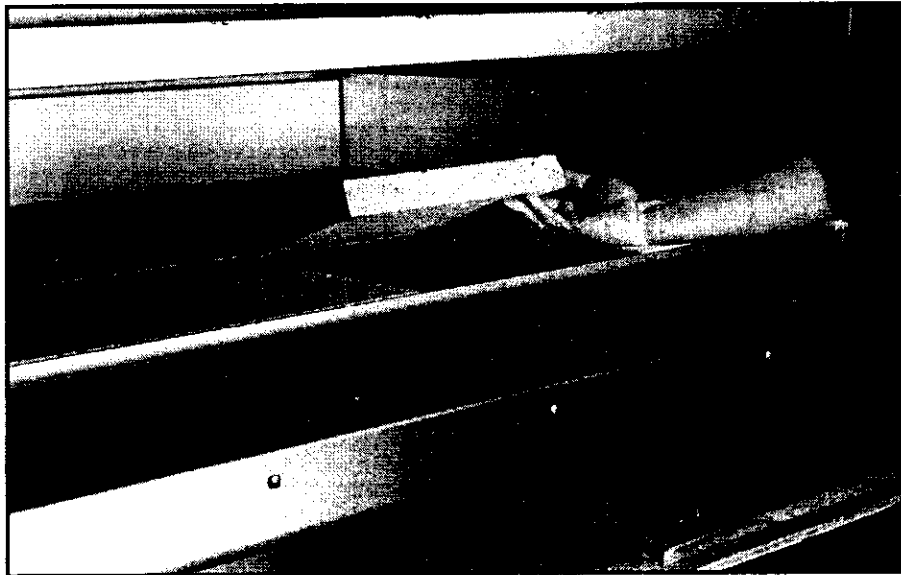

Bottom tile shown in position on "T" bar.

FIGURE 1

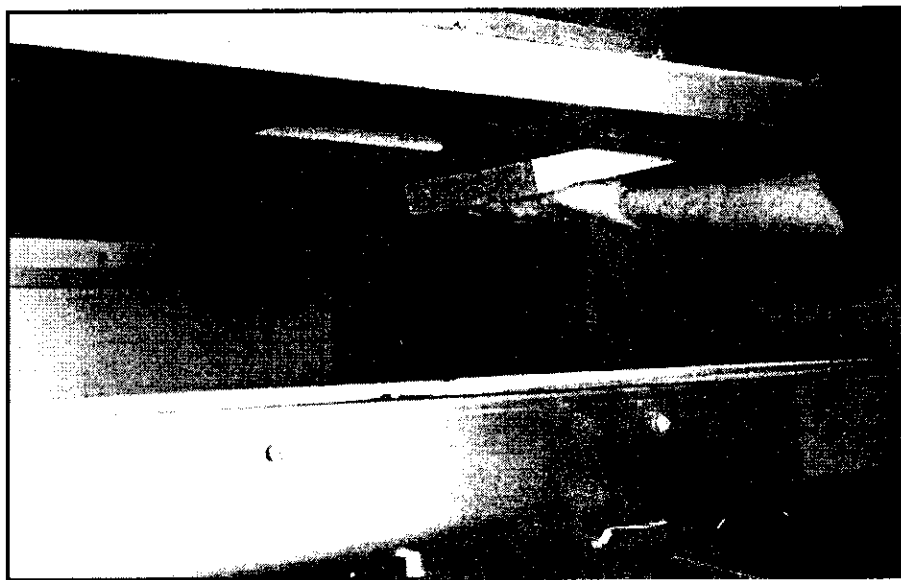

Top of oven showing top tile and "T" bar.

FIGURE 2

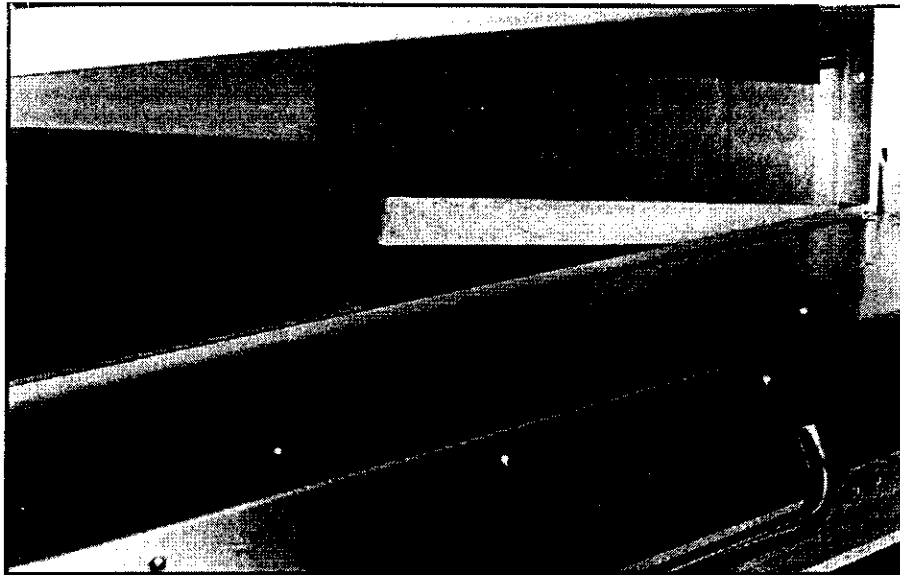

Bottom solid two piece deck on 14P-1. Metal covering removed from sides and back.

FIGURE 3

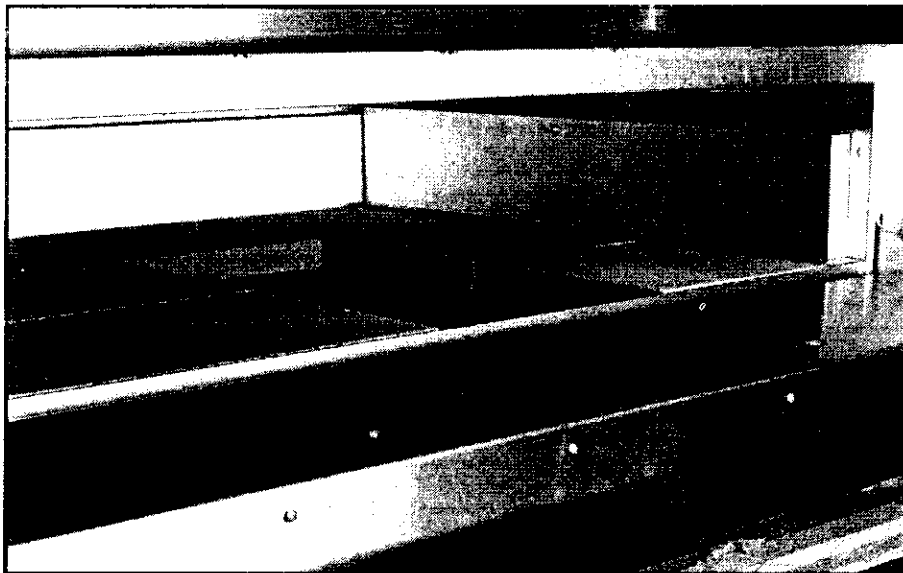

Bottom tile deck in position on channels running from front to back.

FIGURE 4

SERVICE

ADJUSTMENT AND SERVICE

MAIN BURNER

While your oven has been factory adjusted, it sometimes happens that the actual operating conditions are different. Therefore, it may be necessary to make a field adjustment to secure satisfactory performance. The air adjustment should give a medium sharp flame without lifting or flashback. Air shutter is adjusted by loosening screw and rotating air shutter. Tighten screw after adjustment.

THERMOSTAT

The Model FDTH Robertshaw is a heavy duty, high capacity throttling type gas thermostat. When the dial is set at a temperature, the thermostat will open wide allowing maximum flame at the burners. As the temperature begins to rise and reach the temperature setting, thermostat begins to throttle the gas, cutting down burner flame to the amount of gas needed to hold oven at the set temperature. (See Figure 5).

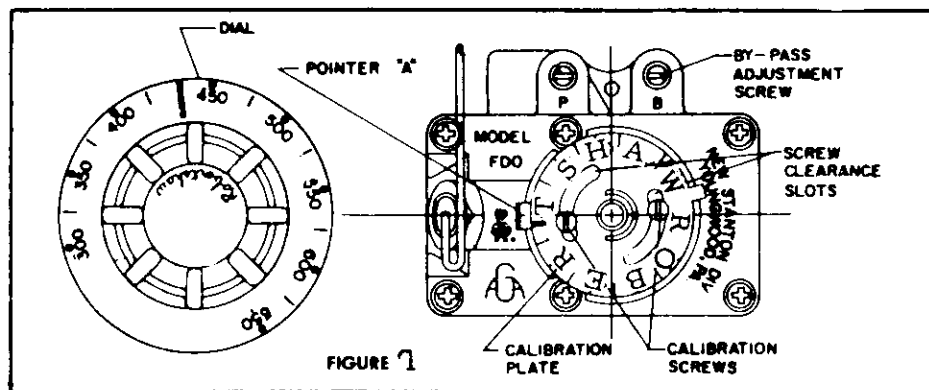

Figure 5

BY-PASS (MINIMUM BURNER FLAME) (See Figure 5)

THIS ADJUSTMENT MUST BE MADE AT THE TIME APPLIANCE IS INSTALLED.

TO ADJUST THIS FLAME (Be sure pilot flame is ignited):

1. Turn dial to 300 °F.
2. Light main burner.
3. After oven temperature rises and remains constant turn dial back to low. This closes the main valve and permits only by-pass gas to burner.
4. Remove dial.
5. With a screwdriver, turn "By-pass Adjustment Screw" counterclockwise to increase the bypass flame or clockwise to decrease it until flame over entire burner is approximately 1/4" high.
6. Replace dial.

RECALIBRATION (See Figure A)

Field recalibration is seldom necessary, and should not be resorted to unless experience with cooking results, definitely proves that the control is not maintaining the temperature to which the dial is set. By pass should always be checked first before calibrating unit. To check oven temperatures when recalibrating, use a potentiometer or a reliable mercury oven thermometer.

SERVICE

1. Place the thermocouple of test instrument or thermometer in the middle of the oven, or medium to be tested.
2. Light the main burner.
3. Turn dial so 500 lines up with "Pointer A" indicator mark.
4. Allow the oven to heat until flame cuts down to by-pass. After sufficient time, check temperature. If the temperature does not read within 15 degrees of the dial setting, recalibrate as follows:
 - A. Pull dial straight off without turning.
 - B. Hold calibration plate and loosen the two calibration lock screws until the plate can be moved independently of the control.
 - C. The calibration plate has no temperature markings. The temperature range between each mark is 25 °F. (between each letter is 50 °F). Turn the calibration plate counterclockwise if the test reading is higher than the dial setting, or clockwise if the reading is lower than the dial setting.
 - D. Replace dial.

NOTE: If the above adjustment is prevented by the two loosened calibration lock screws being in contact with the ends of the screw clearance slots in the calibration plate, remove the screws and after turning the calibration plate to the proper location, reassemble screws in the other tapped holes designed for them. (See Figure A).

SAFETY PILOT VALVE

Model H15HQ-5 BASO is an automatic 100% safety pilot which provides complete gas shut off in event of pilot failure. The safety valve is held closed by spring pressure. When red button is pushed by hand, gas flows to pilot. Pilot heats thermocouple creating a very small amount of electricity. This energizes a magnetic coil under red button and holds valve open, permitting gas to flow to main burner and pilot without holding pressure on red button. In the event of pilot failure, the flow of electricity will stop and spring will stop flow of gas to both pilot and main burner.

SAFETY PILOT VALVE

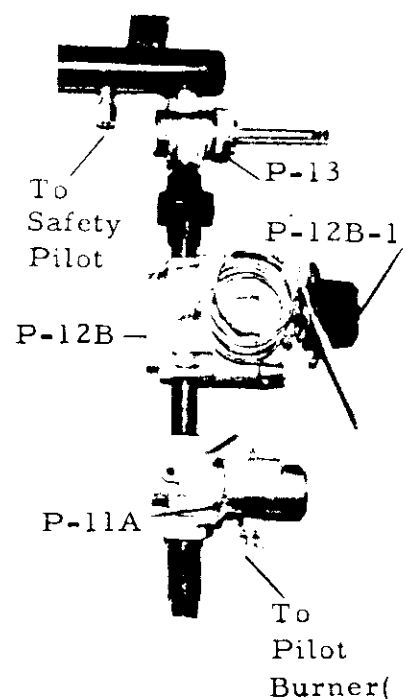

DROPOUT RANGE

MA RANGE OF POWER UNIT ASSEMBLY	
LOW	HIGH
100	300

PILOT BURNER

PILOT SERVICE IN THE EVENT OF PILOT FAILURE

1. If pilot flame burns yellow, clean pilot orifice and pilot burner to insure a steady blue flame. The orifice can be cleaned by washing in a solvent such as trichloroethylene and/or blowing out with air.
2. Flame must surround the thermocouple tip for approximately 1/2 inch.

THERMOCOUPLE OUTPUT

OPEN CIRCUIT MV RANGE	
NORMAL	NOT LESS THAN
25-35	17

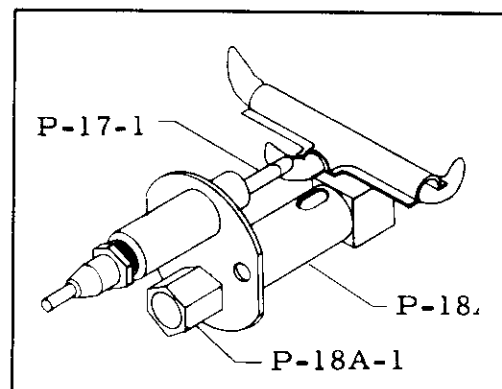

(Figure 7)

MAINTENANCE

GENERAL CLEANING

The complete oven should be given a periodic general cleaning. Lint and grease suspended in the air tend to collect in passages. Therefore, all flueways, air passages and openings, burner ports, primary air openings, etc. should be periodically cleaned to prevent clogging.

CLEANING TIPS

Exterior: Wash painted surfaces with mild soap and water, drying with clean cloth. For S/S surfaces, see Stainless Steel section.

CLEANING STAINLESS STEEL

Stainless Steel is remarkably easy to clean. You can quickly remove fingertips, dust and ordinary stains simply by rubbing the stainless with a clean damp cloth. And it is no trick at all to remove such stubborn, sticky materials as burnt-on grease, dried food particles and coffee stains, if you follow the suggestions offered below.

With reasonably good care, your stainless steel will stay new-looking for years to come. Under ordinary conditions, the secret of keeping your stainless surfaces bright as new is simple: Light but frequent cleaning, usually with no more than a damp cloth. Then dry with a soft cloth.

For slightly more difficult applications, you may use any of the following: (1) ammonia in water, (2) detergent in water, or (3) special solvents, such as alcohol, baking soda, vinegar or turpentine. Follow these with a thorough washing with detergent and hot water, then rinse and dry with a soft, clean cloth. For a high polish, apply a mild abrasive cleanser and rub in the direction of the polish lines to preserve the original finish.

Foods that burn and stick on other metals can discolor stainless, too. But with a stainless steel unit you can remove discolorations by applying a mildly abrasive cleanser such as Bon Ami. To soften an extremely heavy layer of burnt-on grease, cover the layer with an ammonia-soaked cloth for 10 to 15 minutes. You might also use a plastic or stainless steel sponge. Then wash, rinse and dry as usual.

You can eliminate fingerprints on highly polished surfaces by applying a commercial glass cleaner or automobile wax. After you remove the excess cleaner with a soft cloth, a thin protective film remains. If some fingerprints do appear later, they can be easily wiped away with a cloth containing some of the cleaner.

Precautions:

1. Strong bleaches tend to corrode many materials and should not come in contact with stainless steel sinks or utensils longer than 30 minutes. When these chemicals are used, the stainless should be rinsed thoroughly.

2. Tincture of iodine or iron should not remain in contact with stainless surfaces. These solutions, which cause stainless to discolor, should be rinsed off immediately after contact.
3. Some foods, such as mustard, mayonnaise, lemon juice, vinegar, salt or dressings containing these, will attack and corrode stainless. You should never store them in stainless containers.
4. Ordinary steel wool should not be used to clean stainless; particles may lodge in the surface and rust. For difficult cleaning jobs such as removing burned-on foods, "sponges" or pads are recommended. When cleaning a highly polished, mirror finish be especially careful not to scratch the finish.
5. Gritty, hard abrasives will mar a stainless finish and are not recommended.
6. Sharp knives or choppers usually have hard carbon steel edges and will leave their mark on stainless surfaces.

With only a little care, your stainless steel equipment and utensils will remain clean and bright for years to come. Stainless is a hard, rust-resisting metal that adds beauty and lustre to countless household products.

CLEANING BAKING DECK

The baking deck may be cleaned during usage with a stiff brush. If residue (spillage) build up occurs and brush will not remove, a metal scraper may be used with caution. Do not use any liquid cleaners on the deck material. Even water can be absorbed by the deck and result in cracking when reheated.

CLEANING ALUMINIZED INTERIOR

The interior aluminized surfaces should only be cleaned with soapy water. Caustic solutions such as ammonia, lye, soda ash, or oven cleaners should not be used since they will permanently damage the surface.

OPERATIONAL DIFFICULTIES & PROBABLE CAUSES

PILOT BURNER GOES OUT

1. Gas shut off.
2. Poor draft in flue snuffs out flame.
3. Too much draft pulls flame away from thermocouple.
4. Air from fans or register blowing at front of oven.
5. Pilot flame too low.
6. Thermocouple defective.
7. Thermocouple connection on safety pilot loose.
8. Pilot orifice dirty.
9. Safety pilot valve defective.
10. Gas leak at pilot orifice fitting.
11. Restricted or plugged vent on gas pressure regulator.

BURNER FAILS TO COME ON THOUGH PILOT ON

1. Burner valve off.
2. Burner orifice plugged.
3. Thermostat out of calibration.
4. Minimum flame adjustment closed and thermostat setting too low.

OVEN BURNER WON'T THROTTLE DOWN OR OVEN GETS TOO HOT

1. Oven thermostat out of calibration.
2. Minimum flame too high. (Do not lower under 1/4").
3. Broken capillary tube on thermostat.
4. Dirt under thermostat valve seat.

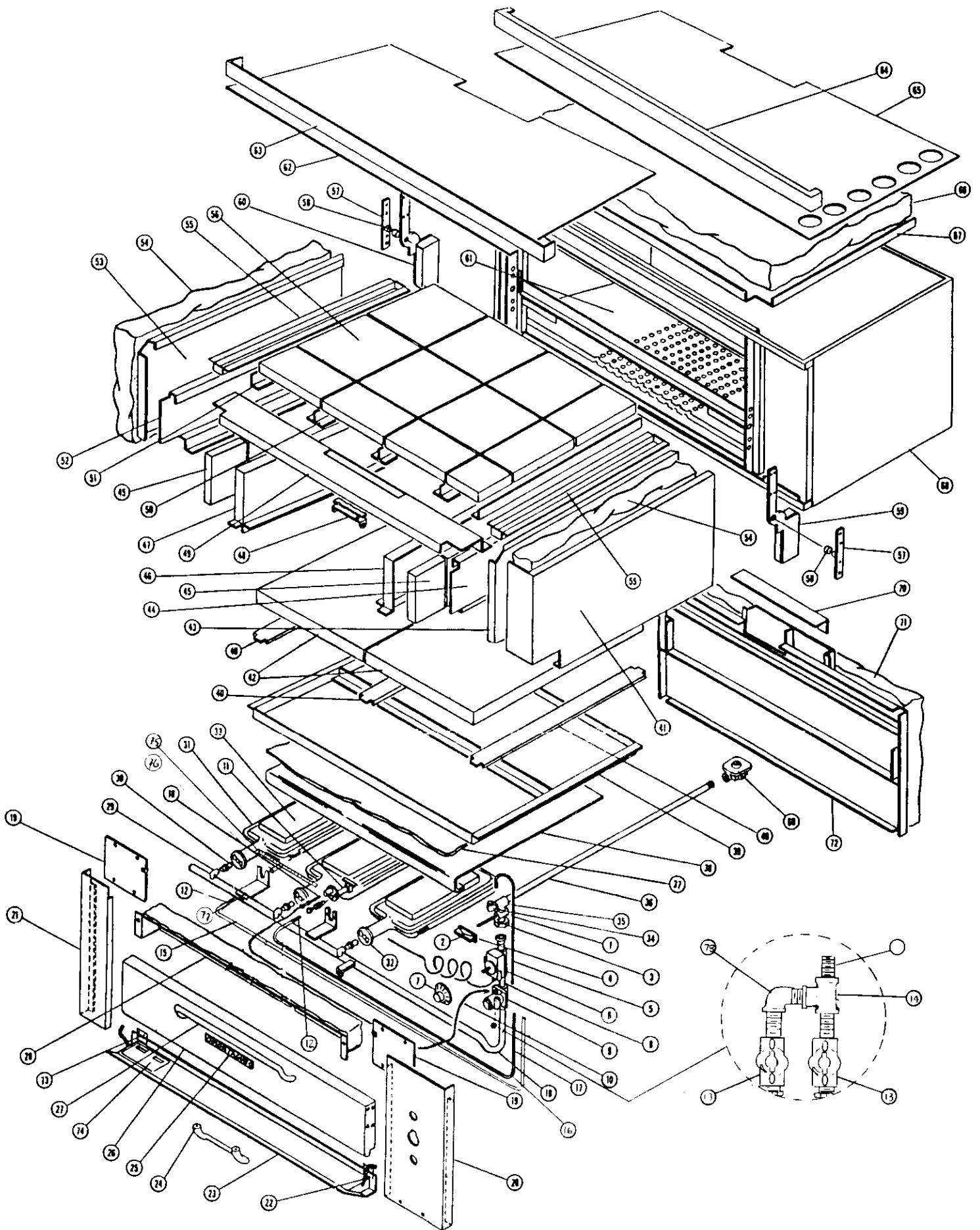

2	02004-4	Handle, Oven Valve	40	04428-8	Channel, Deck Support (13P-1)
3	01183-5	Union - 3/8" NPT x 3/8" NPT	42	28279-0	Cordierite Deck- 15P-1 (3 Required)
4	01149-5	Nipple- 3/8" x 1-1/2"	42	24571-2	Cordierite Deck- 14P-1 (2 Required)
5	01492-3	Tubing; Manifold to Saftey- 1/4" x 18"	42	24572-0	Cordierite Deck- 13P-1 (2 Required)
6	03501-7	Thermostat, FDTH (650 F)	45	01763-9	Tile, Side 7-1/2" x 10-1/2"
7	01976-3	Dial, Thermostat	46	04476-8	Cover, Tile- Right 14P-1
8	01150-9	Nipple- 3/8" x 2"	46	04455-5	Cover, Tile- Left 14P-1
9	01025-1	Safety Valve	46A	04482-2	Cover, Tile- Center 14P-1
10	01036-7	Thermocouple	46A	28178-6	Cover, Tile- Center 15P-1
10A	27876-9	Thermocouple (15P-1)	47	07181-1	Cover, Tile- Right 13P-1
11	01047-2	Pilot Burner, Nat. Gas	47	07180-3	Cover, Tile- Left 13P-1
11	03405-3	Pilot Burner, LP Gas	47A	07755-0	Cover, Tile- Center 13P-1
12	02155-5	Orifice, Pilot, Nat. Gas	48	01942-9	Clip, Thermal Bulb
12	01048-0	Orifice, Pilot, LP Gas	55	28164-6	Deflector, Top (15P-1)
13	22818-4	Valve, Pilot- 1/8" NPTM x 1/4" CC	55	24634-4	Deflector, Top (14P-1)
14	01176-2	Tee, Pipe- 1/8" x 1/8" x 1/8"	55	24636-0	Deflector, Top (13P-1)
15	01225-4	Tubing, Left Pilot- 1/4" x 12"	56	01762-0	Tile, Top (1-1/4" x 10-1/2" x 10-1/2")
16	01491-5	Tubing, Right Pilot- 1/4" x 3"	57	03432-0	Pin, Door
17	05991-9	Tubing, Safety to Pilot- 1/4" x 39-1/2"(13P-1)	58	06474-2	Spacer, Door
17	04410-5	Tubing, Safety to Pilot- 1/4" x 36"	59	04311-7	Trunnion, Door- Complete (Right)
18	01102-9	Manifold, Lower- 3/4" (13P-1 & 14P-1)	60	04312-5	Trunnion, Door- Complete (Left)
18A	28234-0	Manifold, Lower- 3/4" (15P-1)	62	28252-9	Top Cover (Lower) 15P-1
19	24584-4	Cover Plate, Burner Box (14P & 15P)	62	24105-9	Top Cover (Lower) 14P-1
19	24585-2	Cover Plate, Burner Box (13P)	62	24651-4	Top Cover (Lower) 13P-1
20	11885-0	Panel; Right Front- S/S	63	28253-7	Trim Strip- Double Deck (15P-1) S/S
20	11887-7	Panel; Right Front- PTD	63	24622-0	Trim Strip- Double Deck (14P-1) EG
21	11884-2	Panel; Left Front- S/S	63	24623-9	Trim Strip- Double Deck (14P-1) SS
21	11886-9	Panel; Left Front- PTD	63	24621-2	Trim Strip- Double Deck (13P-1) EG
22	06477-7	Chain, Burner Door	63	24620-4	Trim Strip- Double Deck (13P-1) S/S
23	24587-9	Door, Burner Compartment- 14P-1 (EG)	64	28213-8	Panel, Upper Trim (15P-1) S/S
23	24588-7	Door, Burner Compartment- 14P-1 (S/S)	64	24639-5	Panel, Upper Trim (14P-1) EG
23	24589-5	Door, Burner Compartment- 13P-1 (EG)	64	24638-7	Panel, Upper Trim (14P-1) S/S
23	24590-9	Door, Burner Compartment- 13P-1 (S/S)	64	24640-9	Panel, Upper Trim (13P-1) EG
24	02027-3	Handle, Burner Compartment Door	64	24641-7	Panel, Upper Trim (13P-1) S/S
25	19804-8	"Montague"- Chef	65	28210-3	Panel, Top (15P-1)
26	28201-4	Door, Oven- 15P-1 (S/S)	65	23912-7	Panel, Top (14P-1)
26	24606-9	Door, Oven- 14P-1 (EG)	65	23913-5	Panel, Top (13P-1)
26	24607-7	Door, Oven- 14P-1 (S/S)	69	01039-1	Regulator, Pressure Nat. Gas- 3/4"
26	24605-0	Door, Oven- 13P-1 (EG)	69	01040-5	Regulator, Pressure LP Gas- 3/4"
26	24604-2	Door, Oven- 13P-1 (S/S)	73	01969-0	Hinge, Burner Box Door (Right)
27	03175-5	Handle, Oven Door	73	01971-2	Hinge, Burner Box Door (Left)
28	04605-1	Cover, Firebox- 13P-1	74	01811-2	Rating Plate (Old Style)
28	04604-3	Cover, Firebox- 14P-1	74	24717-0	Rating Plate w/ AGA Seal CGA
28	28184-0	Cover, Firebox- 15P-1			NOT SHOWN
29	01275-0	Elbow, Street- 1/8" NPT		04546-2	Leg- 12" Painted
30	01049-9	Orifice, Main Burner & Fitting (Nat. Gas)		10183-4	Leg- 15" Painted
30	01050-2	Orifice, Main Burner & Fitting (LP Gas)		04631-0	Flue Deflector, PTD
31	03345-6	Burner, Oven- Complete		04629-9	Flue Deflector, S/S
32	02037-0	Air Mixer		03119-4	Downdraft Diverter, PTD
33	09518-4	Baffle, Oven Burner		03132-1	Downdraft Diverter, S/S
34	01274-2	Elbow- 3/8" NPT x 1/4" Tube (Old Style)	75	24658-1	Pilot, Tube
34	01288-2	Connector, Male 1/8" NPTM x 1/4" Tube (New Style)	76	24775-8	Orifice, Spud (Nat)
35	01175-4	Tee, Reducing- 3/4" x 3/8" x 3/8"	76	24776-6	Orifice, Spud (LP)
36	06383-5	Manifold, Gas Supply, 3/4" Rear (14P-1 & 15P-1)	77	24292-6	Pilot Tube Support
36	06384-3	Manifold, Gas Supply, 3/4" Rear (13P-1)	78	01136-3	Elbow-Street, Pipe
37	28242-1	Insulation Pad (15P-1)			
37	04403-2	Insulation Pad (14P-1)			
37	04404-0	Insulation Pad (13P-1)			
38	28189-1	Deflector, Removable (15P-1)			
38	03535-1	Deflector, Removable (14P-1)			
38	03534-3	Deflector, Removable (13P-1)			

WARNING

If not installed, operated and maintained in accordance with the manufacturer's instructions, this product could expose you to substances in fuel or in fuel combustion which can cause death or serious illness and which are known to the State of California to cause cancer, birth defects or other reproductive harm.

The State of California enacted the California Safe Drinking Water and Toxic Enforcement Act of 1986, (Prop. 65), which "prohibits any person in the course of doing business from knowingly and intentionally exposing any individual to a chemical known to the State of California to cause cancer or reproductive toxicity without first giving clear and reasonable warning to such individuals." The Governor's Scientific Advisory Panel added carbon monoxide to the list of hazardous chemicals known to cause reproductive harm.

In order to establish full compliance with Proposition 65, we attached a yellow warning label to each gas fired unit manufactured by the Montague Company.

Carbon monoxide would not be present in concentrations that would pose a "significant risk" to the consumer when the equipment is installed, operated and maintained as follows:

1. Installed in accordance with all local codes, or in the absence of local codes, with the current National Fuel Gas Code Z223.1.
2. Installed under a properly designed and operating exhaust hood.
3. Connected to the type of gas for which the unit is equipped.
4. Proper appliance pressure regulator installed on the gas supply line and adjusted for the manifold pressure marked on the rating plate.
5. Adequate air supply to the unit.
6. The equipment is operated in the manner intended using the proper utensil for that type of appliance.
7. Keep the equipment clean and have it checked periodically.
8. Burner air adjustments, mechanical maintenance and repairs should be performed by qualified service personnel.

If the equipment is not installed, operated and maintained in accordance with the above, concentrations of carbon monoxide in excess of the established limits could present in the kitchen environment.

ALL PERSONNEL IN THE WORKPLACE WHO MAY BE SUBJECT TO ANY EXPOSURE OF CARBON MONOXIDE MUST BE WARNED OF SUCH POSSIBLE EXPOSURE. THIS WARNING SHOULD BE CONVEYED IN A MANNER SO THAT IT IS CLEARLY UNDERSTOOD BY THE EMPLOYEE, AND THE EMPLOYEE SHOULD BE ASKED IF IN FACT HE OR SHE UNDERSTANDS THE CORRECT METHOD OF OPERATION OF THE EQUIPMENT AND THAT A RISK OF EXPOSURE EXISTS IF THE EQUIPMENT IS OPERATED IMPROPERLY.



THE MONTAGUE COMPANY

1830 Stearman Avenue, P.O. Box 4954, Hayward, CA 94540-4954

IMPORTANT

When ordering parts, to eliminate mistakes and facilitate delivery, always give the following information:

Serial No. _____

Model No. _____

Change No. _____

Name & No. of Part

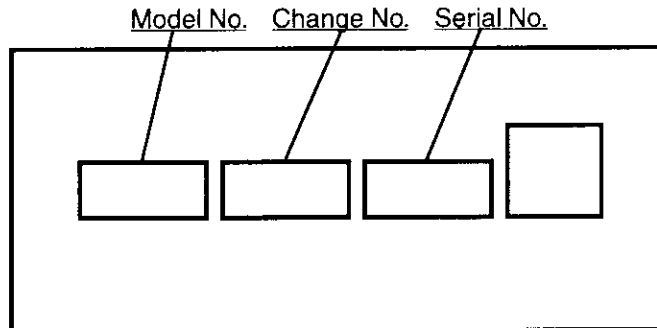

Pizza Oven Name Plate

The Montague Company
1830 Stearman Avenue
P.O. Box 4954
Hayward, CA 94540-4954

P/N 4529-2 9/96