



*Made in France*

*Assembled in the USA*

# USER MANUAL

## OCTOPUS 3500

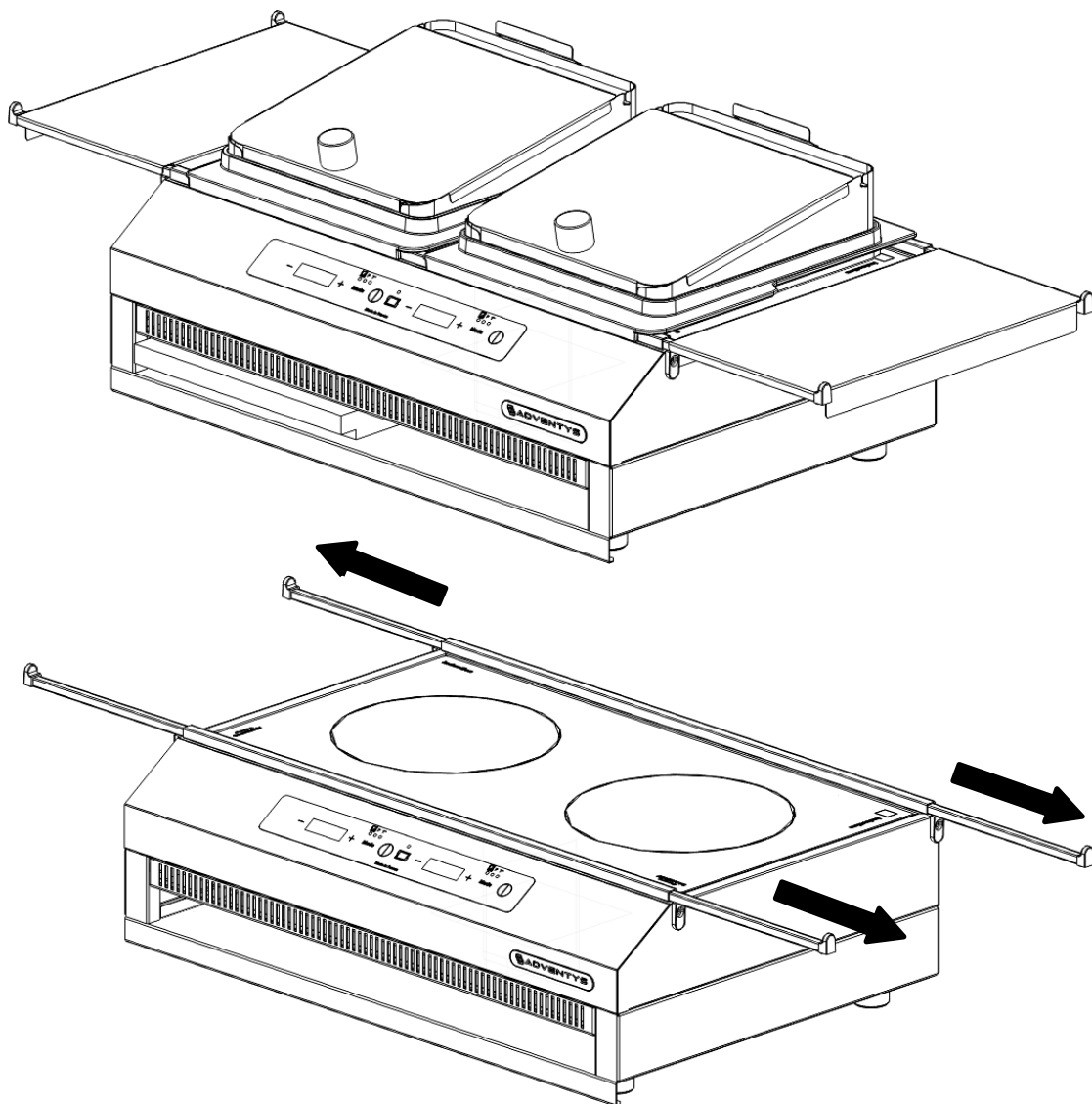

100 Niantic Avenue – Suite 100 – Providence, Rhode Island 02907 – USA

TEL: 401-273-3300 FAX: 401-273-3328

[www.equipex.com](http://www.equipex.com) e-mail: [service@equipex.com](mailto:service@equipex.com)



## IMPORTANT SAFEGUARDS

When using electrical appliances, basic safety precautions should always be followed, including the following:

1. Read all the instructions before use.
2. The manufacturer cannot be held responsible for any damage related to non-compliance with safety and installation instructions.
3. The appliance should not be used to store anything.
4. Never use appliance with a cracked glass surface. If the glass surface should crack, disconnect the appliance immediately to avoid the risk of electric shock.
5. Never use aluminum foil for cooking, or put products packaged with aluminum or frozen in aluminum packs directly onto the appliance. The aluminum will melt and damage your appliance.
6. Be careful when wearing objects such as rings, watches, credit cards electronics or anything similar which can heat up if placed very close to the hob when using the appliance.
7. Metal objects such as knives, forks, spoons and lids should not be placed on the surface, as they can get hot.
8. Do not touch hot surfaces; use handles or knobs.
9. To avoid electric shock, do not immerse the power cord, or any part of the unit, in any water or liquid.
10. This appliance is not intended for use by persons (including children) with reduced physical, sensory or mental capabilities, or with lack of experience or knowledge, unless they have supervision or have been given prior instructions concerning the use of the device by the person responsible for their safety.
11. Please keep away from children.
12. Unplug appliance from the electrical outlet when not in use, and before cleaning. Allow appliance to cool before installing or removing any parts or accessories, and before cleaning.
13. Do not operate any appliance with a damaged cord or plug, or if appliance should sustain damage, or malfunction in any way. In this event, return appliance to the manufacturer for examination, repair or adjustment.
14. The use of accessories and/or attachments not recommended by the appliance manufacturer may cause injury or damage to the appliance, and may void your warranty.
15. Turn the unit off by means of its control panel; do not rely on the pan detector.
16. Use only induction ready cookware of the type and size recommended.
17. Do not use outdoors.
18. Do not allow the power cord to hang over the edge of a table or counter, or to be exposed to hot surfaces, as damage may occur.
19. Do not place appliance on or near a burner or in a heated oven.
20. Keep a distance of at least 4 inches from all sides
21. To disconnect an appliance, first turn all controls to the 'off' position; then unplug the power cord from the wall outlet.
22. Do not use appliance other than for its intended use.
23. Never leave the device running unattended.
24. SAVE THESE INSTRUCTIONS FOR LATER USE!

# INSTRUCTIONS AND SAFETY INFORMATION

Technical information	
Model	OCTOPUS 3500
Power	3500W
Volts	208/240V/60/1
Control panel	1 dual capacitive touch control panel
Product dimensions	24in.W x 16-1/4in.D x 6.7/8in.H (plus 7in.ea.side)
Net weight	105 lbs. with accessories
Shipping weight	145 lbs.

## Principals of Induction

When the appliance is switched on, as soon as a power level is selected, the electronic circuits produce induced currents into the bottom of the pan or cooking plate which instantly transmits the heat to the food.

## Unboxing the content of your box

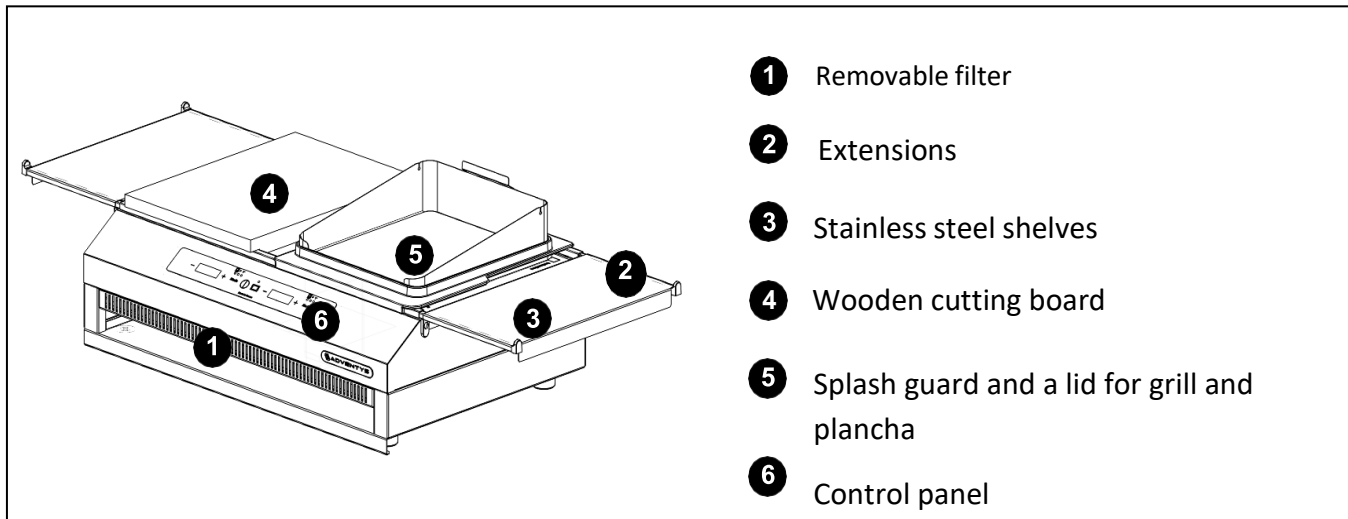

## BEFORE FIRST USE

Some surfaces of your device are covered with a protective film. Remove the film before the first use.

Before using your device, clean the surfaces with a damp cloth. We also recommend that you wipe all the accessories with a clean damp cloth to remove any dust residue.





## CONTROL PANEL



Control panel	
	Switch on/off your device
	Turn on double plancha mode.
<b>Mode</b>	Choose between power level, temperature, grill or plancha accessories mode
	Set power level/temperature or timer

Displays	
1-30	Power level
H	Residual heat (allow to cool)
30° - 250°	Temperature (Celsius)
tE / Po	Temperature or power levels
Grill	Grill Mode (grooved plate)
PLAn	Plancha Mode (smooth plate)

## ACCESSORY STORAGE COMPARTMENT

On the front of your product, below the removable filter, is a storage space for your accessories. You are able to store the wooden cutting board, and either the plancha or cast iron grill plate.

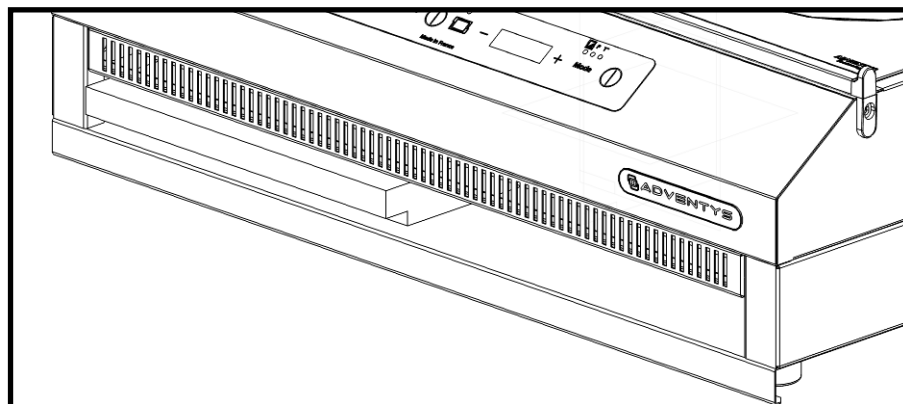



# PRECAUTIONS FOR USE



Cast iron is a heat-conducting material, your plancha and your grill remain hot for a long time even after the appliance has been switched off.

Use pot holders to handle your accessories and make sure to let them cool before cleaning.



Do not place your accessory on a non-heat resistant surface!



Always use the **Mode** button according to your accessory (grill / plancha).

**NEVER** select a temperature or power setting when using your cast iron accessories, they risk breaking.

### 3. Setting a zone in power level

- Once the product is on press the **Mode** button until the display shows **Po**.
- The **P** indicator light comes on, then use the +/- selection buttons to adjust the power level.
- The value flashes until the heating zone reaches the required power.

Your device can deliver a total power of 3400W, with a maximum of 3000W on a single zone. Each zone can deliver 3000W when the second zone is off. If the 2 cooking zones are on, the sum of the powers of the 2 cooking zones cannot exceed 3400W. If you have turned on a zone with a certain power and want to turn on the second zone on a power level that would exceed the total power of 3400W, the first zone will go down automatically and the maximum power will always be the same.

Examples:

- Left zone = 400W; maximum power on right zone = 3000W
- Left zone off: maximum power on right zone = 3000W
- Right zone = 1700W; maximum power on left zone = 1700W
- Right zone = 2500W; maximum power on the left zone = 900W
- Left zone = 2500W; requested power on right zone = 2000W;
  - o left zone will go down to 1400W

## POWER LEVEL CORRESPONDS TO A STEP OF 100W

Power level	Power in watts	Power level	Power in watts
1	100	16	1600
2	200	17	1700
3	300	18	1800
4	400	19	1900
5	500	20	2000
6	600	21	2100
7	700	22	2200
8	800	23	2300
9	900	24	2400
10	1000	25	2500
11	1100	26	2600
12	1200	27	2700
13	1300	28	2800
14	1400	29	2900
15	1500	30	3000

#### 4. Setting a zone in temperature setting

- a. The temperature settings are in CELSIUS for even more precision.
- b. Once the product is on press the **Mode** button until the display shows **tE**.
- c. The **T°** indicator light comes on; then use the +/- selection buttons to adjust the temperature.
- d. The value flashes until the heating zone reaches the required temperature.
- e. You can select a temperature between 30C° to 250C°.
- f. The temperature setting goes up in steps of 1 degree C° up to 120C°, then will go up by increments of 10 degree C° up to 250C°.
- g. Conversion chart from Celsius to Fahrenheit provided below.



<b>TEMPERATURE CONVERSION</b>		
<b>C°</b>	<b>F°</b>	
30°	86	<b>Chocolate Tempering</b>
40	104	
50	122	
60	140	
70	158	
80	175	
90	194	
100	212	<b>Water Boiling</b>
110	230	
120	248	
130	266	
140	284	
150	302	
160	320	<b>Typical Baking Temperatures</b>
170	338	
180	356	
190	374	
200	392	
210	410	
220	428	
230	446	
240	464	<b>Searing</b>
250	482	

**6. Switch off your device**

- a. To turn off your device, press the button  again until you hear an audible signal.
- b. Once off, the display panel will continue to show the residual heat indicator (**H**) which remains on until the unit the hotplates have cooled down sufficiently.

# OPERATING DETAILS SUMMARY

## Cycling of Mode Touch

Press 1 – PLAN = Plancha

Press 2 – GR = Griddle

Press 3 – Po = Power

Press 4 – tE = Temperature (C°)

## Temperature (CELSIUS) – “tE”

Start: 30C° x 1C° each touch until 120C°

Then: +10C° each touch until 250C°

## Power (WATTS)

1. Each number increase is 100W higher
2. 1-30 each side x1
3. Maximum power both sides: 3400W
4. Maximum power set on one side “30” (3000W)
  - a. other side can be set to “4” (400W)

EXAMPLES	
ZONE 1	ZONE 2
5	29
6	28
7	27
17	17
30	4

## Applications

1. Cook both sides
2. Warm one side / cook one side
3. Warm both sides
4. Off one side / warm other side
5. Off one side / high power cooking other side

# COOKWARE

**Only use cookware suitable for induction cooking.**

- **Container test**

Place your cookware on the induction zone in the *POWER* mode. If the indicator light stays lit, then the cookware is compatible. If the indicator light blinks constantly, then the cookware is not compatible.

- **Type of containers**

- **Enameled steel containers** with or without non-stick coating.
- **Stainless steel containers suitable for induction.**
  - Most of the ferromagnetic stainless-steel containers are suitable if they pass the container test (saucepans, pot, pan, skillets).

- **WARNING**

Glass, ceramic or earthenware, aluminum (without special bottom), copper and certain non-magnetic stainless-steel containers are incompatible with induction cooking. The selected power level indicator will keep flashing to alert you.

- **Recommended dimensions**

On each of the cooking zones, you can use pots with a base diameter of 6-1/4" up to 11". If you use a larger container, it may not be able to fit between the front and rear top rails.

## A POOR-QUALITY PAN WILL INEVITABLE AFFECT THE EFFICIENCY OF YOUR INDUCTION COOKER

### Using your appliance safely

#### The Induction Principle

When switching on the appliance, and when a heat level is selected, the electronic circuits produce currents induced in the bottom of the cookware which instantly heat the food. The food is cooked with a very high energy output with **virtually no energy loss.**

For the attention of people with active implants and pacemakers.

The functioning of the appliance complies with the electromagnetic interference standards. . It is designed so as not to interfere with other electrical equipment to the extent that it complies with the same regulations.

Your induction cooking appliance generates magnetic fields in its very close environment. So as to have no interference between your cooking appliance and a pacemaker, the latter must be designed in accordance with the regulations concerned. In this respect, we can only guarantee the conformity of our own product. Please check with the manufacturer or with your doctor concerning the pacemaker's compliance or any potential incompatibilities.

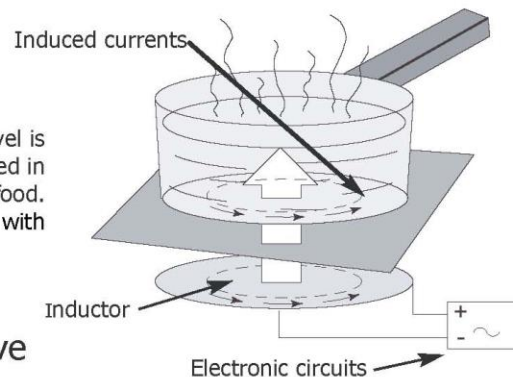

## CARE AND MAINTENANCE

- Avoid impacts on the vitroceramic glass cook top. The glass is very strong, but it is not unbreakable.
- Avoid scraping cookware on the cook top, which could scratch the glass and wear off screen printing on the surface.
- Do not use cookware with rough or uneven bases, which may scratch the vitroceramic glass.
- Place your cookware in the center of the hob for proper operation.
- Do not leave empty cookware on the cooking zone with the unit in operation, as this could cause the cookware to overheat and warp.
- Do not heat an unopened can of food as it may burst.
- If using very little liquid in cookware with a non-stick coating, such as Teflon, do not preheat on very high power.
- The maximum power level should only be used for boiling and frying.
- Metal objects, such as cutlery, cooking utensils or even jewelry should not be placed on the operating appliance as they can get very hot, very quickly.
- Physical damage, misuse or abuses to the appliance are not covered under the warranty.
- Do not leave or store your device unprotected outdoors without adequate protection, as it may damage the electronic system or other parts of the device.

## CARE AND MAINTENANCE

**WARNING: Disconnect (unplug) electrical power cord and allow the appliance to cool before cleaning.**

Cleaning is very important in maintaining a safe and well working machine. The metal filter, located under your appliance, protects your appliance from dust and grease, and should be cleaned after each use. It can be cleaned in a sink using soap and water, or put into the dishwasher. The filter must be completely dry before reinstalling into the unit. Use a cloth or sponge dampened slightly with a soap and water mixture to clean all exterior stainless-steel surfaces and glass. Use a clean lint-free cloth to remove the excess water. Make sure no water enters the unit through ventilation holes. A glass scraper can be used on the cook top for stubborn stains. Glass cook top cleaner is also widely available, and can be used on the glass to aid in cleaning.

**DO NOT use an abrasive sponge**

**DO NOT wash the induction machine under running water**

**DO NOT spray the exterior housing with any liquid**

**DO NOT allow water to drip into the housing or onto electrical components**

## CARE AND MAINTENANCE - CONTINUED

- **Cleaning your cast iron accessories**

Cleaning your cast iron grill or plancha accessories is essential to ensure their efficiency and durability. Cleaning the cast iron preserves the quality of the food as well as the performance of your appliance.

- **Cold cleaning cast iron accessories**

- Check that the attachment is completely cool for safe handling.
- Remove the cast iron accessory from the unit for easier cleaning.
- Use a standard cleaner and a non-abrasive sponge.

- **Hot cleaning cast iron accessories**

- Carefully clean during or directly after cooking.
- Cleaning is easier because the food has not yet adhered completely to the cast iron.

- **2 METHODS:**

- Scrape with a spatula in between cooking batches and properly dispose of food residue.
- If you prefer to clean your accessory at the end of use, then remove the cast iron accessory from the unit with a potholder, use white vinegar which will loosen overcooked foods instantly and effortlessly. Scrape residue with a spatula to remove and dispose of properly.



**Cast iron is a heat conductive material! Do not handle a hot plate with bare hands; use a potholder.**



**Cast iron is sensitive to thermal shock. Never pour cold water on your cast iron plate, as it may crack.**

**To prevent rust from appearing:** rub oil on your cast iron plate with a cloth or paper towel to cover the surface with a thin protective layer. Store it in a dry place in its original packaging or covered with cling film. Regular cleaning will extend the life of your accessory.

**In case of rust:** Pour a thin layer of oil on the surface and place your accessory on your induction appliance. Turn on the heating zone in grill / plancha mode at a low setting. Then use a spatula to remove excess rust.



**Use non-abrasive utensils (spatula) to avoid damaging the cast iron.**

## CARE AND MAINTENANCE - CONTINUED

You should inspect all parts on a regular basis to ensure that all are in proper working order. If a part is damaged, have the unit repaired by the manufacturer prior to returning the unit to operation. If you need any further assistance, please email us at [service@equipex.com](mailto:service@equipex.com), or call us at 1-800-649-7885 ext. 240.

### Troubleshooting

PROBLEM	POSSIBLE CAUSES	ACTION
A light blinks when switching on	Normal operation	Nothing
No power when turning unit on	No power at outlet or defective outlet wiring	Correct problem and test again
Fan runs for a few minutes after the appliance is switched off	The unit is cooling down; normal operation	Nothing
The unit is not working. The lights on the control panel are off	There is no power to the appliance, no power to outlet or blown internal fuse	Restore power to outlet or return unit for service
"F" then "-" appears on the control panel	A control panel button is stuck on	Clean front panel or return for service
"F" then "7" appears on the control panel	The circuit board is overheating	Make sure fan is operating and unit is properly ventilated. Clean filter.
The appliance is not functioning, another code is displayed	Problem with circuit board	Call manufacturer
After turning unit on, the set cook level indicator keeps blinking	Cookware not induction ready or too small	See cookware section
The cookware is making noise during cooking	This is a vibration generated by the induction of the cookware	This is normal with some types of cookware and will not damage the unit
There is a slight odor during first operation	This is normal with any new appliance	After using for about 30 minutes the odor will go away

**If the glass cracks discontinue use, unplug the unit immediately and contact the manufacturer.**

**Error message on Control Panel:** In case of display on the keypad of ERXX (with XX 01 to 19), disconnect and reconnect the device. If the problem persists, contact our customer service for assistance: [service@equipex.com](mailto:service@equipex.com) or 1-800-649-7885 ext. 240.



100 Niantic Avenue, Providence, RI 02907; 401-273-3300; fax 401-273-3328;

[www.equipex.com](http://www.equipex.com); [service@equipex.com](mailto:service@equipex.com)

## LIMITED TWO-YEAR WARRANTY - INDUCTION

Your new **EQUIPEX** product is warranted to the original purchaser for a period of **TWO** years from the date of shipment by Equipex. All non-mechanical products such as pans are warranted for defects for a period of 90 days from shipment by Equipex.

This limited warranty is against defects from original factory imperfections in material and/or workmanship and includes labor for replacement of defective parts, provided repairs are performed by the manufacturer. Our obligation under this warranty is limited to repairing or replacing any part or parts thereof. The CUSTOMER must inform the manufacturer of warranty coverage and provide a copy of the dated sales or delivery receipt BEFORE WARRANTY REPAIRS BEGIN. Replacement parts and accessories are warranted for ninety (90) days from the date of purchase when purchased separately and will be verified by dated sales receipt or packing slip for that item. All parts or accessories replaced under warranty must be returned to the manufacturer.

This warranty applies only to equipment under normal use and service in the U.S.A. and Canada. It does not apply to any item that has been repaired or altered in any way so as, in the judgment of **EQUIPEX**, to affect its reliability.

In many cases, the unit or parts requiring service may be replaced with a new or rebuilt unit/part at the discretion of Equipex. Equipex will pay for the freight both ways on the unit/part requiring service and the replacement unit/part. Customer is responsible for packing the unit/part being returned in the packaging sent by Equipex, affixing shipping labels and noting appropriate RMA designation on the exterior of the box. A standby credit card authorization may be required to assure the return of the original unit. Please coordinate the details with the Equipex customer service department.

Any material, labor and related costs associated with removal of the product for repair or replacement, including electrical, sealing, cabinetry, sheet metal, fuse replacement, breaker resetting and/or any other expenses, are not covered by this warranty.

### THE FOLLOWING ARE NOT COVERED UNDER WARRANTY:

1. Damage caused by abuse, misuse or dropping or other similar incidental damage caused by, or as a result of, customer failure to follow assembly, operation, cleaning, user maintenance or storage instructions.
2. Labor to replace inoperative parts such as bulbs, plugs or racks due to normal wear and tear or abuse.
3. Materials or labor to repair scratched, stained, chipped, pitted, dented or discolored surfaces, attachments or accessories.
4. Labor charges to install or test attachments or accessories, which are replaced for any reason.
5. **SHIPPING DAMAGE:** Inspect merchandise immediately on receipt. Sign for and notify carrier if shipment is damaged. All claims must be filed with carrier by purchaser. Keep all original packaging material for carrier inspection. Visible and hidden damages not covered by warranty.
6. Products placed or stored in the equipment are not subject to this warranty and no responsibility is assumed thereof.

**THIS WARRANTY IS GIVEN EXPRESSLY AND IN LIEU OF ALL OTHER WARRANTIES, EXPRESSED OR IMPLIED, FOR MERCHANTABILITY AND FOR FITNESS TOWARD A PARTICULAR PURPOSE AND CONSTITUTES THE ONLY WARRANTY MADE BY EQUIPEX, LLC. IT NEITHER ASSUMES, NOR AUTHORIZES ANY PERSON TO ASSUME FOR US, ANY OTHER LIABILITY IN CONNECTION WITH THE SALE OF THE SUBJECT EQUIPMENT.**

For service, please call EQUIPEX at 1-800-649-7885, menu option # 3