

Operator's Manual

MODULAR DROP-IN AUTO-FILL

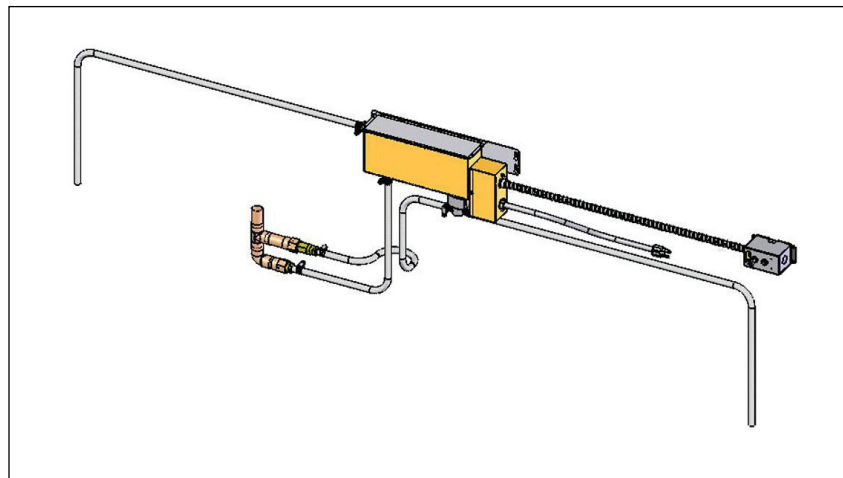

| Item | Description | Voltage | Watts | Plug |
|-------|---------------------------|---------|-------|-------|
| 26806 | Modular Drop-In Auto-Fill | 120 | 16 | 5-15P |

Thank you for purchasing this Vollrath equipment. Before operating the equipment, read and familiarize yourself with the following operating and safety instructions. **SAVE THESE INSTRUCTIONS FOR FUTURE REFERENCE.** Save the original box and packaging. Use this packaging to ship the equipment if repairs are needed.

SAFETY PRECAUTIONS

To ensure safe operation, read the following statements and understand their meaning. Please read carefully.

WARNING

Warning is used to indicate the presence of a hazard that *can* cause severe personal injury, death, or substantial property damage if the warning is ignored.

CAUTION

Caution is used to indicate the presence of a hazard that *will* or *can* cause *minor* personal injury or property damage if the caution is ignored.

NOTE

Note is used to notify people of installation, operation, or maintenance information that is important but not hazard-related.

For Your Safety!

These precautions should be followed at all times. Failure to follow these precautions could result in injury to yourself and others.

To reduce risk of injury or damage to the equipment:

- Read and understand all installation and operation instructions before installing or operating equipment.
- Have this equipment installed by qualified service personnel.
- Use only grounded electrical outlets matching the nameplate rated voltage.
- Do not spray controls or outside of equipment with liquids or cleaning agents.
- The control box must be installed in a dry location.
- Do not use an extension cord with this equipment. Do not plug this equipment into a power strip or multi-outlet power cord.
- Do not operate without water.
- Keep equipment and power cord away from open flames, electric burners or excessive heat.
- Do not operate unattended.
- Do not operate if equipment has been damaged or is malfunctioning in any way.

FUNCTION AND PURPOSE

This product is intended to maintain the water level in a hot food unit at a predetermined level.

This equipment is not intended for household, industrial or laboratory use.

OPERATIONAL STATEMENT

This Auto-fill unit operates by filling a water reservoir that represents an additional well. This reservoir has a float switch installed that is closed when the tank is empty. When the Auto-Fill system is turned on, the closed float switch allows power to flow to the solenoid valve, opening the solenoid valve and allowing water to flow into the drain system through a check valve.

As water fills the drain line, it will fill each well and the Auto-Fill reservoir at approximately the same rate. When the water reaches the float switch, the switch will open, stopping the power supply to the solenoid valve and the solenoid valve will return to its normally closed position stopping the flow of water into the system.

UNPACKING THE EQUIPMENT AND INITIAL SETUP

When no longer needed, dispose of all packaging and materials in an environmentally responsible manner. Have the unit installed only by qualified service personnel. This unit must be installed in accordance with any local and national plumbing codes.

- A shut-off valve to control the fresh water supply to this product is required.
- This unit requires a 120Volt 15Amp electrical outlet.
- Units using this auto-fill unit **MUST NOT SHARE A DRAIN LINE** with any other units that do not have the same well depth.
- Multiple units with the same well depth may share a drain line provided they are level to each other within $\frac{1}{4}$ ".

NOTE: A water filter to remove particles that may clog the solenoid valve is strongly recommended.

1. Remove all packing material and tape, as well as any protective plastic from the equipment.
2. Clean any glue residue left over from the plastic or tape.
3. If installing this Auto-fill on a Vollrath drain manifold, cut off the pipe cap from the end of the drain manifold assembly that is on the opposite end of the main drain valve.
4. Solder the Auto-Fill manifold assembly (A) to the open end of the drain line (B) from step 2 making sure the auto fill manifold is level with the existing drain manifold. Figure 1.

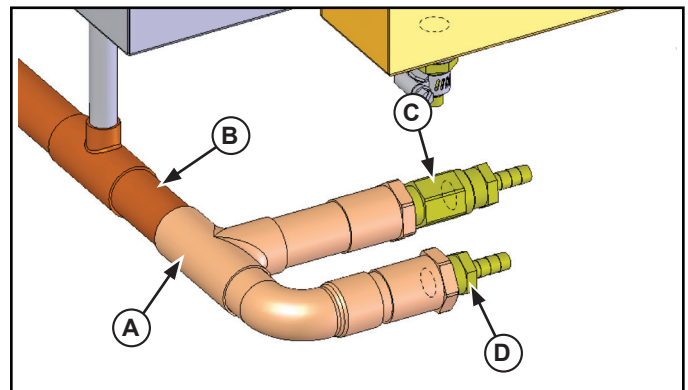

Figure 1. Drain Line and Manifold Assembly .

5. **For installation with Rectangular Drop-In** For initial setup, mount the Auto-Fill main body water reservoir (B) level to the bottom of any full size Vollrath hot well (C) unit outer skin. Mark and use appropriate length fasteners to mount reservoir (B) assembly in a level position (D) to the bottom of the well assembly (A). See Figure 2.
6. **For use with Round Soup Drop-In:** Install the reservoir (B) 5/8" (15 mm) below the bottom of a Vollrath round soup drop in unit outer skin. See Figure 2.
1. The adjustment procedure above should be used with soup pots with the understanding that the water level the unit will maintain is the water level when there is a soup pot in use. The recommended 5/8" (15 mm)" placement of the reservoir below the soup warmer (In the installation section above) will maintain water at the water level mark in the well. However at this level, if a soup insert is placed into the soup warmer that has water filled to this mark without an insert in place, when inserted the insert will displace some of the water up the sides of the soup warmer. Because the water will level out in the entire system, this may cause the reservoir tank of the auto-fill unit to overflow.

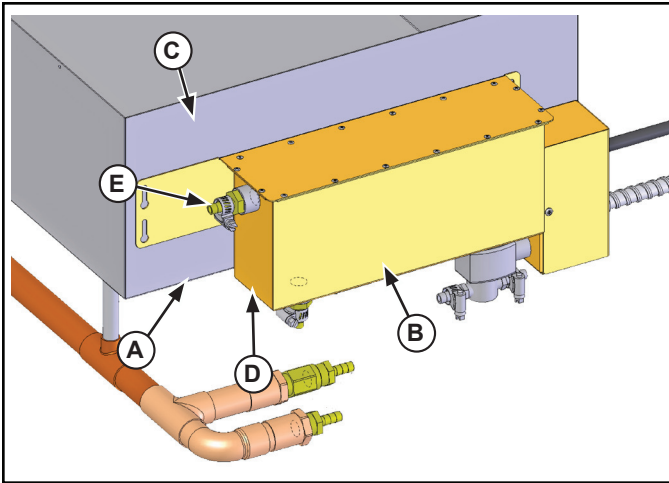

Figure 2. Water Reservoir and Well Assembly.

7. Mount the auto-fill control box (A) at any convenient dry location close to an access door. See Figure 3.

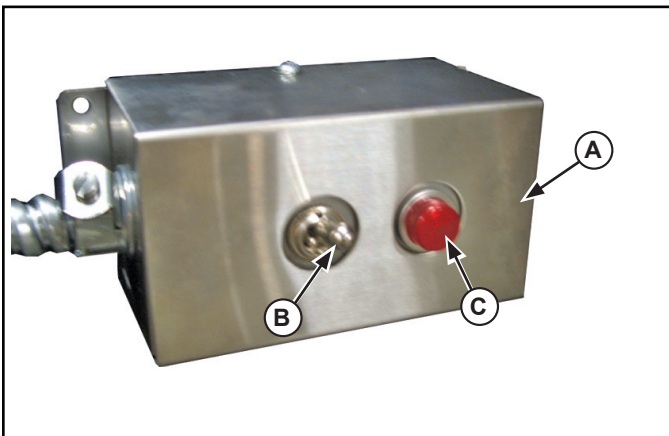
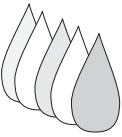

Figure 3. Control Box, Switch and Light.

| | |
|---|---|
|  | <p>⚠ WARNING</p> <p>Water Contamination Hazard. The overflow drain line must not be connected to any drain. It must be routed to an open drain leaving a air gap separating the overflow drain line from the top of the open drain reservoir.</p> |
|---|---|

8. Using the section of the flexible marked and/or coming from outlet (E) side of the water tank, route this line to an OPEN FLOOR DRAIN. This drain MUST not be directly plumbed to the auto fill unit. This is done to prevent contamination of the fresh water supply. See Figure 3.
9. Using the section of the flexible hose (A) coming from the "IN" or "I" side of the solenoid (B) connect this hose to your fresh water source. See Figure 4.

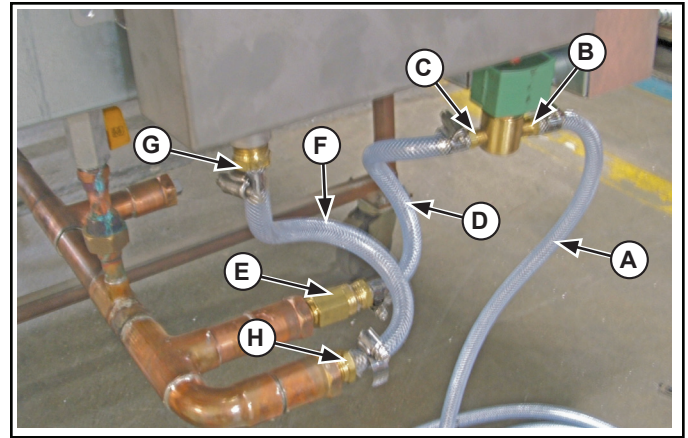

Figure 4. Solenoid Valve, Flexible Hose, and Fittings.

10. Using the section of the flexible hose (D) coming from the "O" side of the solenoid (C) connect this hose to the ant-siphon valve (E).
11. Using the section of the flexible hose (F) coming from the reservoir fitting (G) to the fitting (H).

START UP AND TESTING

1. Plug the auto-fill control box into a grounded 120 Volt 15 Amp electrical outlet.
2. Verify the main drain valve is in the CLOSED position to prevent water from draining out. Be sure the individual well drains are in the OPEN position to allow water to fill the wells from the drain manifold.
3. Turn the fresh water supply valve on. Start with the valve in the full open position.
4. Turn on the Auto-fill system using the switch on the control assembly. The red indicator light should come on indicating power is supplied to the unit and water should flow into the system.

NOTE: If a continuous stream of water begins to flow out of the overflow tube when filling the unit, stop filling and drain the unit. Close the water supply valve from step 3 part way to reduce water flow. Refill unit. Continue this process until water does not flow out of the overflow when filling the unit. It is normal to have small amounts of water flow out the overflow while the unit is filling.

5. The auto-fill system may cycle on and off a few times, with delays, before the water level is stabilized. The number of cycles and delays are dependant on water pressure, number of wells filling, etc. Do not attempt to adjust the water level until the system has fully stabilized. When the system does not cycle on or off after a full minute, the system should be stabilized.
6. When the system is stabilized, check the water level in each of the wells. For proper water level control it is important the hot food unit be level. Each well should have approximately the same amount of water.
7. If the water level is too low, loosen (do not remove) the screws used to mount the reservoir assembly. Lift the reservoir assembly up approximately 1/8". Retighten the screws. There may again be a delay before the system begins to fill. Allow the system to stabilize again and re-check the water level.
8. Continue the adjustment until you have the water level adjusted to the desired level. The water level should not be adjusted above 1/2" of water.
9. For most efficient heating and performance, use approximately 1/4" of water in each well.

1.

OPERATION



WARNING

Electrical Shock Hazard.

Keep water and other liquids from entering the inside of the equipment. Liquid could contact the electrical components and cause a short circuit or an electrical shock. Do not spray water or cleaning products. Do not use equipment if power cord is damaged or has been modified.

1. Check the drain valve of the Hot Food Unit. Make sure it is in the closed position to prevent water from draining out. Generally, the valve is in the off position when the handle of the valve forms a “T” with the body of the valve.
2. Turn Auto-Fill control on. Operate the Vollrath Hot Food Table in accordance with the Operating and Safety Instructions that were provided with the Hot Food Table.
3. At the end of the serving period, turn the Auto-fill control off before opening the drain valve for the Hot Food Unit. If the unit is drained with the Auto-fill on, the unit will continue to fill and will not completely drain.
4. Follow the shut down and cleaning procedures that were sent with the Hot Food Table. No special cleaning is required for the Auto-fill system.

TROUBLESHOOTING CHART

| Problem | It might be caused by | Course of Action |
|--|---|---|
| No Water in the wells. | Check to make sure there is power supplied to the Auto-fill unit. | Verify the switch is ON. Verify the water supply valve is open. Refer to the installation section and be sure all steps were followed properly. |
| Wells are not getting hot enough. | There may be too much water in the wells. | Change the water level to a maximum depth of 3/8”. |
| No Water in the wells. | The reservoir assembly may be set too low. | Loosen the fasteners and raise the assembly. |
| The water continues to run and the water flows out the over flow tube. | There may be a clog in the drain assembly preventing water from reaching the float or the drain overflow may be clogged causing an air lock in the Auto-Fill reservoir. | Make sure drain line is open and water is able to reach the reservoir. Also, make sure the auto fill system is plugged in and grounded. |
| The wells continue to fill beyond the desired water level. | The float switch may be installed incorrectly. | Disconnect power and remove the control box cover on the outside of the reservoir tank. Check to see that the arrow molded into the white plastic nut portion of the float switch is pointing DOWN. |

SERVICE AND REPAIR

There are no user serviceable parts within this appliance. To avoid serious injury or damage, never attempt to repair the equipment or replace a damaged power cord yourself. Do not send equipment directly to the Vollrath Company. Please contact the qualified professional repair service listed below.

VOLLRATH Technical Service • 1-800-628-0832



ELECTRICAL DRAWING - DROP-IN AUTO-FILL ~ 26806

ENGLISH

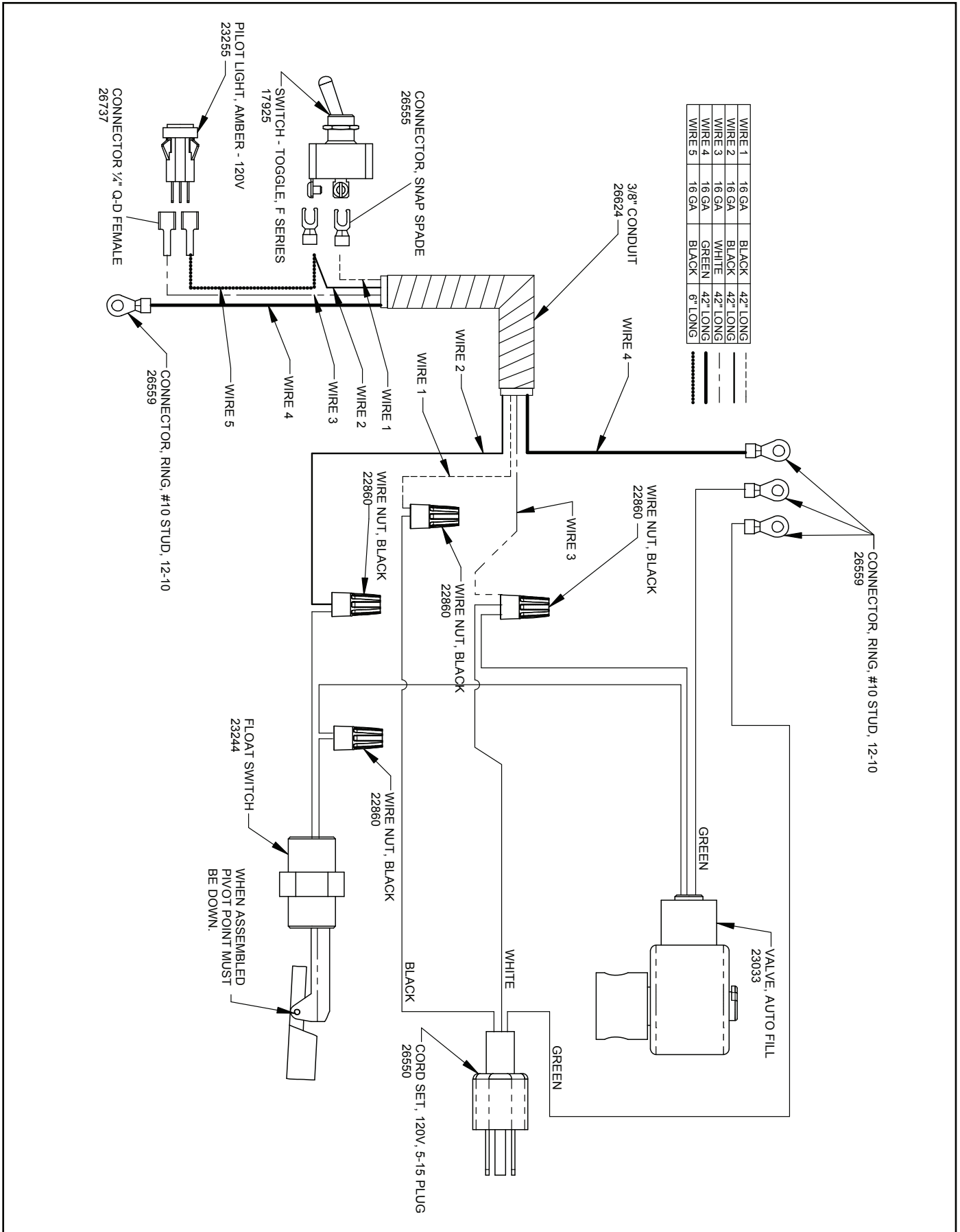

SPARE PARTS LIST - DROP-IN AUTO-FILL ~ 26806

| Callout | Part Number | Description |
|---------|-------------|--------------------------------------|
| 1 | 44081 | Autofill Water Reservoir Subassembly |
| 2 | 44082 | Autofill Solenoid Subassembly |
| 3 | 44083 | Autofill Control Box Subassembly |
| 4 | 26681 | 7/16" - 3/4" Hose clamp |
| 5 | 26682 | 3/8" I.D. Hose |
| 6 | 44084 | Autofill manifold Subassembly |
| 7 | 23255 | Pilot Light, Amber, 120V |
| 8 | 44082 | Autofill Solenoid Subassembly |
| 9 | 44081 | Autofill Water Reservoir |

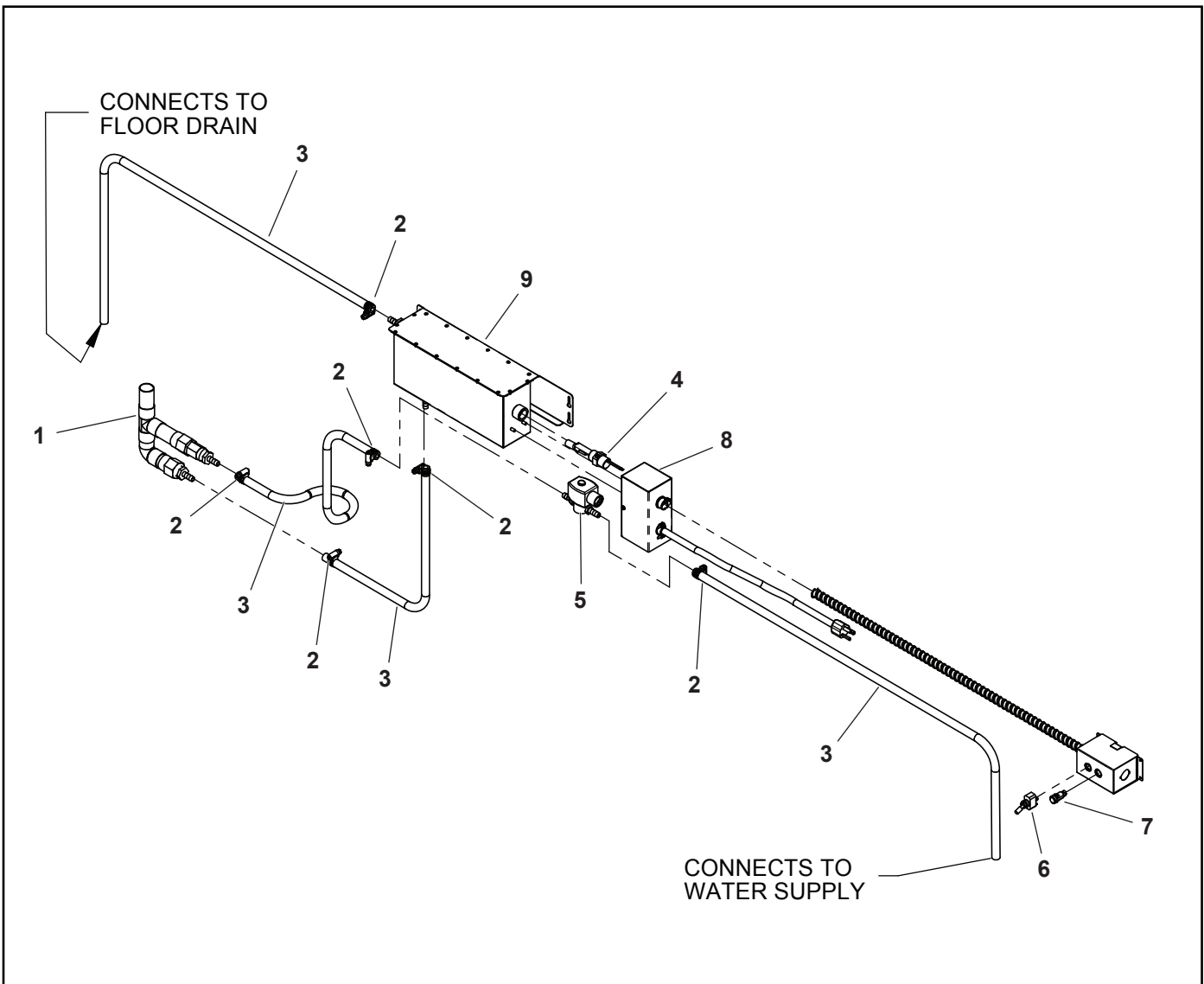
EXPLODED VIEW - DROP-IN AUTO-FILL ~ 26806

WARRANTY STATEMENT FOR THE VOLLRATH Co. L.L.C.

The Vollrath Company LLC warrants the products it manufactures and distributes against defects in materials and workmanship for a period of one year, except as specifically provided below. The warranty runs 12 months from the date of original installation. (End user receipt)

1. Refrigeration compressors – The warranty period is 5 years.
2. Replacement parts – The warranty period is 90 days.
3. Fry pans and coated cookware – The warranty period is 90 days
4. EverTite™ Riveting System – The warranty covers loose rivets only, forever.
5. Cayenne® Heat Strips – The warranty period is 1 year plus an additional 1 year period on heating element parts only.
6. Ultra and Professional Induction Ranges – The warranty period is 2 years.
7. Mirage and Commercial Induction ranges - The warranty period is 1 year.
8. ServeWell® Induction Workstations – The warranty period is one year on the workstation table and 2 years on induction hobs.
9. Slicers – The warranty period is 10 years on gears and 5 years on belts.
10. Mixers – The warranty period is 2 years.
11. Extended warranties are available at the time of sale.
12. Vollrath – Redco products – The warranty period is 2 years.
13. Optio / Arkadia product lines – The warranty period is 90 days.
14. All non-stick products (i.e. fry pans and surfaces) are 90 days for the non stick surfaces.

All products in the Jacob's Pride® collection, including the following, have a lifetime warranty:

- NSF Certified One-Piece Dishers
- NSF Certified Spoodle® Utensils
- NSF Certified Heavy-Duty Spoons with Ergonomic Handle
- NSF Certified Heavy-Duty Basting Spoons
- Heavy duty Turners with Ergonomic handle
- One-Piece Tongs*
- Heavy-Duty One-Piece Ladles*
- Nylon Handle Whips
- One-Piece Skimmers
- Tribute®, Intrigue®, and Classic Select® Cookware*

*Jacob's Pride® warranty does not cover Kool-Touch®, non stick coatings and silicone handles.

Items sold having no warranty:

- Meat Grinder Knives
- Light Bulbs in Convection Ovens and Hot Food Merchandiser
- Oven Door Seals
- Oven Door Glass
- Hot Food Merchandisers / Display Case Glass
- Calibration and set up of gas equipment
- Slicer / Dicer blades (table top food prep) – Redco and Vollrath

THIS WARRANTY IS IN LIEU OF ANY OTHER WARRANTIES, EXPRESS OR IMPLIED, INCLUDING ANY IMPLIED WARRANTY OF MERCHANTABILITY OR FITNESS FOR A PARTICULAR PURPOSE

As The Vollrath Company LLC's only responsibility and the purchaser's only remedy, for any breach of warranty, The Vollrath Company LLC will repair or, at its option, replace the defective product or part without charge, except as otherwise provided below:

- For refrigeration compressors and the second year of the warranty on Cayenne® Heat Strips and mixers, The Vollrath Company LLC will provide the repaired or replacement part only; and the buyer will be responsible for all labor charges incurred in performing the repair or replacement.
- To obtain warranty service, the buyer will be responsible to return to The Vollrath Company LLC any product (other than gas equipment that is permanently installed) weighing less than 110 lbs. or located outside of a 50-mile radius of a certified technician designated by The Vollrath Company LLC to perform warranty repairs. If a Vollrath Technician cannot be contacted check the website for service contact points. (Please refer to the Product Catalogue for weights and sizes of product)
- No remedy will be available for products that have been damaged by accident, carelessness, improper installation, lack of proper setup or supervision when required, neglect, improper use, installation or operation contrary to installation and operating instructions or other causes not arising out of defects in materials or workmanship. At the buyer's request, The Vollrath Company LLC will repair and or replace such products at a reasonable cost.
- No remedy will be available for slicers where blade has not been sharpened (Refer to owner's manual for sharpening instructions)
- No remedy will be available for mixers damaged by changing gears while unit is running or overloading, in either case as determined by a Vollrath Certified Technician
- Warranty work must be authorized in advance by The Vollrath Company LLC. See the operating and safety instructions for each product for detailed warranty claim procedures.
- No remedy will be available for product returned and found to be acceptable to the product specification.
- No remedy will be available under any warranty not registered as required below.

LIMITATION OF LIABILITY:

THE VOLLRATH COMPANY LLC SHALL HAVE NO LIABILITY FOR INCIDENTAL OR CONSEQUENTIAL DAMAGES OF ANY KIND, WHETHER BASED UPON NEGLIGENCE OR OTHER TORT, BREACH OF WARRANTY, OR ANY OTHER THEORY.

WARRANTY PROCEDURE

On all warranty calls, the following process and information is required:

- All warranty claims will start with a call to Vollrath Technical Service support line.(800-354-1970).
- A technical support professional will work to diagnose the issues, and provide the details for the service solution.
- Name and phone number of person calling
- Business name, street address, city, state and zip
- Model and serial number
- Date of purchase and proof of purchase (Receipt)
- Name of dealer where unit was purchased

NOTE: Vollrath will not accept products sent without the proper procedure being followed.

Important:

TO MAKE A CLAIM FOR ANY REMEDY UNDER THIS WARRANTY, YOU MUST REGISTER YOUR WARRANTY.

REGISTER TODAY

ONLINE: Register your warranty on-line now at www.Vollrathco.com

NO WEB ACCESS: If you do not have access to the web, kindly register by completing the warranty registration form and faxing it to The Vollrath Co. LLC office in the country of purchase.

| WARRANTY REGISTRATION | | | |
|---|---|--|--|
| BUSINESS NAME | | | |
| KEY CONTACT NAME | | EMAIL | |
| STREET ADDRESS | | | |
| CITY | STATE | ZIP CODE | |
| COUNTRY | PHONE | FAX | |
| MODEL | | ITEM NUMBER | |
| SERIAL NUMBER | - | - | - |
| OPERATION TYPE | | | |
| <input type="checkbox"/> Limited Service Restaurant | <input type="checkbox"/> Full Service Restaurant | <input type="checkbox"/> Bars and Taverns | <input type="checkbox"/> Supermarket |
| <input type="checkbox"/> Convenience Store | <input type="checkbox"/> Recreation | <input type="checkbox"/> Hotel/Lodging | <input type="checkbox"/> Airlines |
| <input type="checkbox"/> Business/Industry | <input type="checkbox"/> Primary/Secondary School | <input type="checkbox"/> Colleges/University | <input type="checkbox"/> Hospitals |
| <input type="checkbox"/> Long-Term Care | <input type="checkbox"/> Senior Living | <input type="checkbox"/> Military | <input type="checkbox"/> Corrections |
| REASON FOR SELECTING OUR PRODUCT | | | |
| <input type="checkbox"/> Appearance | <input type="checkbox"/> Full Service Restaurant | <input type="checkbox"/> Availability | <input type="checkbox"/> Sellers Recommendation |
| <input type="checkbox"/> Ease of Operation | <input type="checkbox"/> Versatility of Use | <input type="checkbox"/> Price | <input type="checkbox"/> Brand |
| WOULD YOU LIKE TO RECEIVE OUR FULL-LINE CATALOG AND REMAIN ON OUR MAILING LIST? | | | <input type="checkbox"/> Yes <input type="checkbox"/> No |



www.vollrathco.com

The Vollrath Company, L.L.C.
1236 North 18th Street
Sheboygan, WI 53081-3201
U.S.A.

Main Tel: 800.628.0830
Fax: 800.752.5620

Technical Services: 800.628.0832
Service Fax: 920.459.5462

Canada Service: 800.695.8560

© 2010 The Vollrath Company, L.L.C.

