

- ✓ Increase Pineapple Sales up to 400%
- ✓ Increase Branding (machine custom wrap for theater effect)
- ✓ Increase Traffic to Store and Customer Satisfaction
- ✓ Increase Options (cut fruit, spears)
- ✓ Decrease Labor Costs

"Best feature (of the grocery store) is a free pineapple corer. It is fast and amazing, cuts them in spears rather than rings...will definitely be on my weekly route for pineapple." -Jen H.

PIÑABAR USA Inc.
THE FRESHFRUIT FUNFACTOR

THE FRESH FRUIT EXPERIENCE



READY TO GO IN JUST
20
SECONDS



PIÑABAR RETURN ON INVESTMENT:

- Average increase in pineapple sales has ranged from 50% to 400%.
- Pay off your machine in under 5 months with just 50 pineapples per day.
- Consider a \$1 upcharge for spears and pay off your Piñabar in less than 2 months.

Profit while promoting good health.

800-627-2886 • sales@juicernet.com • www.juicernet.com



TRAFFIC AND STOP POWER

- GENERATING TRAFFIC IN YOUR STORE
- FITS INTO ROUTING VISION "GET THEM TO THE FRESH CORNER"
- BOOST SALES



GENUINELY FRESH PINEAPPLE

GET YOUR FRUIT STRAIGHT
FROM THE PINEAPPLE

"The Piñabar is so easy to use! It only requires 3 steps and takes seconds to have a peeled cored pineapple. I usually buy two and put one in the freezer." -Carol K.

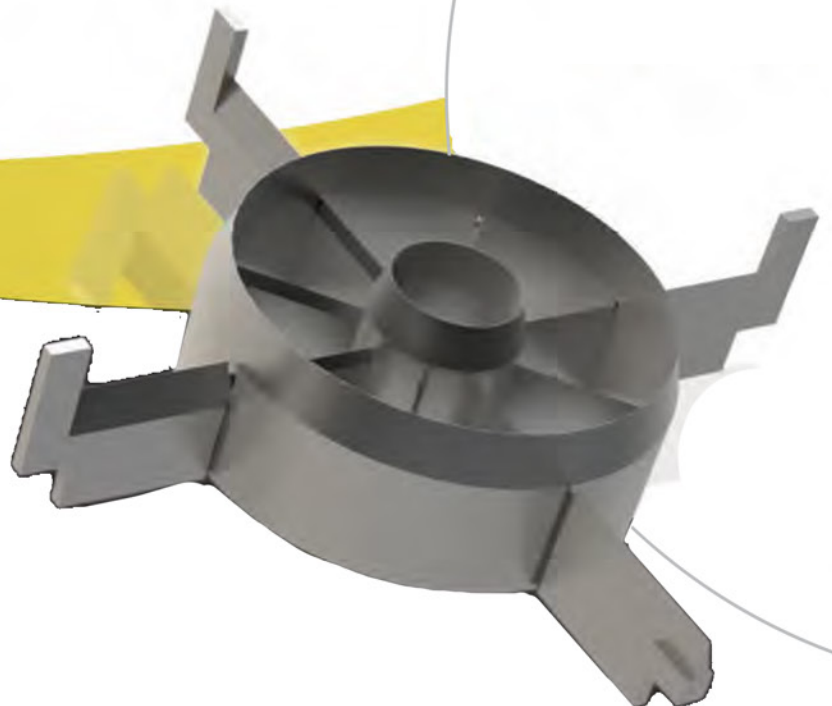

USER EXPERIENCE

- EASY TO USE
- OFFERS THE BEST SELF-SERVICE
- APPEALING PRESENTATION

INSTANT
PEELED
PINEAPPLE

CORED OR SPEARS

EASY TO CLEAN

CLEAN IN 10 MIN. BY TRAINED OPERATOR

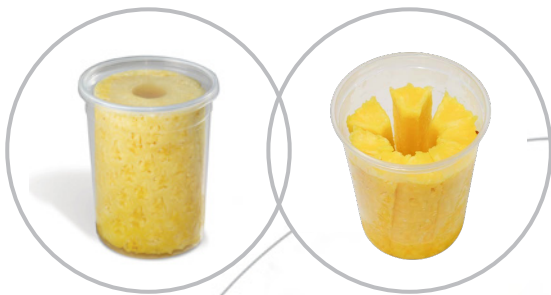

BRANDING
INSTANT
STOP POWER
FRESH
EXPERIENCE
EASY

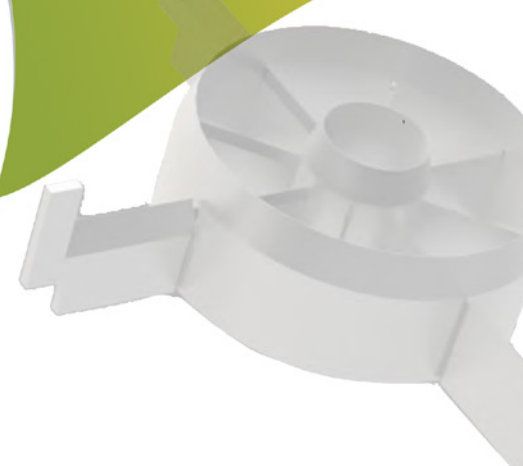

- BLADES AVAILABLE FOR PINEAPPLE TYPES 5,6,7,8,9
- ON WHEELS AND EASY TO MOVE AROUND

TECHNICAL DATA

PRODUCT SPECIFICATIONS:

Dimensions: 76"H x 29"W x 32"D

Weight: 725 lbs.

Color: Fully customizable

Blades: Available for pineapple types 5-9; always use the correct blade set for each size.

Waste container capacity: 40 lbs. of peel (25 pineapples)

Capacity: 5/min

Cleaning: We recommend cleaning once per day, at the end of each operational day.

Waste container and user manual included with each machine.

ELECTRICAL SPECIFICATIONS:

120V, 60Hz single phase 20 AMP

Service on a dedicated circuit.

Power: 350 watts

Sound level: < 70 dB

SHIPPING SPECIFICATIONS:

Height: 85 in.

Width: 48 in.

Depth: 48 in.

Weight: 750 lbs.

PINEAPPLE CONTAINER SPECIFICATIONS:

Diameter top: 4.6 in.

Diameter bottom: 3.6 in.

Height: 4.9 in.

Pineapple sizes 5 and 6 = 1000 ml container

Pineapple sizes 7 and 8 = 850/870 ml container

WARRANTY:

1 year parts and 90 days labor

Piñabar is manufactured by:



www.dutchfoodtechnology.com



Piñabar is distributed by:



Since 1982, we have been specializing in juicers and corers with the highest quality equipment available in the industry today and have juicers that will process anything from apples to wheatgrass and even sugarcane.

