



**VENANCIO USA**  
ONE GOAL: DURABILITY - 100% MANUFACTURED

3125 John P Curci Drive, unit 6  
Hallandale Beach, FL 33009-2024  
BRAZILIAN INDUSTRY  
E-mail: [support@venanciousa.com](mailto:support@venanciousa.com)  
Web site: [www.venanciousa.com](http://www.venanciousa.com)



**VENANCIO USA**  
ONE GOAL: DURABILITY - 100% MANUFACTURED

# Installation and Operation Manual

## RANGE

### MODELS

S240

S360

S36-24-2

### FOR YOUR SAFETY

Do not store or use gasoline or other flammable vapors or liquids in the vicinity of this or any other appliance.

### WARNING

Improper installation, adjustment, alteration, service, operation or maintenance can cause property damage, injury or death. Read the installation, operating and maintenance instructions thoroughly before installing, operating or servicing this equipment.

### NOTICE

Instructions must be posted in a prominent location that will provide the user of this equipment with procedures, in the event he/she smells and/or detects gas. This information must be obtained by consulting the local gas utility.



Certified to  
ANSI/NSF4

## WARRANTY TERM

METALÚRGICA VENÂNCIO LTDA offers a warranty to manufactured equipment as is specified below:

\*Every alleged manufacturing defect must be analysed only by technical assistance from VENÂNCIO. When proven, an eventual manufacturing defect repair will be free of charge.

\*Equipment repaired without proper authorization from the manufacturer or altered, disassembled and/or utilized ajar from the indications presented in their respective guides, are not covered by this warranty.

\*The warranty refers only to the normal use of the equipment, considering the following of the recommendations and instructions contained in the guide that comes with the product

\* For all purposes, the brand gives legal guarantee of two (2) years from the date of issuance of the purchase invoice, being mandatory its presentation to the customer service presented under this warranty term .

\* It is important to consider that glass, light bulbs, resistors, contactors, fuses, relays, solenoids, digital controllers and thermostats, are not covered by this warranty.

\* In the case of its electric motors, being manufactured by a third party, when defective should be sent to its authorized service.

\* This guarantee refers only to the parts and components manufactured by METALÚRGICA VENÂNCIO LTDA, covering also labor costs in such repairs.

\* It is the clients responsibility to communicate any findings of manufacturing defect to METALÚRGICA VENÂNCIO LTDA through the local distributor.

\* In case of bulky equipment (roasters, ovens, heating stoves, industrial ovens, etc.), technical assistance, when necessary, carry out the visit directly to the customers location/establishment. In the other hand, small sized equipment (heaters, plates, saucers, pots, sandwich, drinking fountains, coolers, etc.), the customer must, on their own, direct them to any of the brand's authorized service.

\* Defects in electrical, improper installation, shipping damage done by third parties or weather invalidate the warranty.

**IMPORTANT:** only assemble of the product with safety equipment (goggles, leather gloves, etc.) and suitable tools to the specific product. VENÂNCIO will not be held responsible for any injury derived from the lack of attention and care, as well as improper use of the equipment, even when in operation.

## 12. PARTS LIST - S36-24-2

S36-24-2		
QTY	DESCRIPTION	CODE
1	ASSY., BACK SPLASHER	8.01.25.36001100
2	SHELF	8.01.25.06000060
3	GRATE, TOP	8.01.06.01000006
4	SUPPORT, TOP GRATE	8.01.25.06000016
5	RIGHT SIDE	8.01.25.06000011
6	ASSY., RIGHT SIDE LINING	8.01.38.00130001
7	LEFT SIDE	8.01.25.06000066
8	ASSY., LEG	8.01.25.00000500
9	RACK, RIGHT SIDE LINING	4.02.05.02100585
10	DEFLECTOR, OVEN	8.01.25.00000040
11	ASSY., OVEN BOTTOM LINING	8.01.25.36001200
12	GRIDDLE, OVEN	4.02.07.05500655
13	PAN, STOVE DRIP	8.01.25.36010001
14	ASSY., BODY	8.01.25.36001300
15	DOOR, LEFT HOOK OVEN	4.02.05.00012899
16	SPRING DRIVE	8.01.38.00007002
17	SPRING, OVEN DOOR	4.02.05.00012853
18	PANEL, LOWER	8.01.25.36010006
19	ASSY., DOOR	8.01.25.36001400
20	KNOB	4.03.04.17031401
21	KNOB, OVEN	8.97.01.00221029
22	BEZEL, OVEN KNOB	8.97.01.01221029
23	APRON	8.01.25.36010003
24	VALVE, ABJC THERMOSTAT	8.97.01.00057579
25	REST, PLATE	8.01.25.36000032
26	COUPLING, SPRING	8.01.25.04000056
27	BURNER, OVEN/GRIDDLE	8.01.06.01000007
28	AIR SHUTTER, INTERNAL	8.01.25.00000015
29	AIR SHUTTER, EXTERNAL	8.01.25.00000014
30	PILOT, OVEN	4.01.01.00000201
31	ELBOW, 3/8"NPT x 5/8"UNEF	8.01.25.00009046
32	VALVE, SAFETY	8.97.01.00001502
33	FITTING, 3/8"NPT	8.01.25.00009053
34	ELBOW, 3/8"NPT x 3/8"	8.01.25.00009043
35	FIXER, SAFETY VALVE	8.01.25.00000041
36	SUPPORT, SAFETY VALVE	8.01.25.00000047
37	REDUCTION, 5/8" x 22mm x 1/8"NPS	2.80.29.00004635
38	VALVE, GAS MANUAL	3.97.01.00000500
39	PLUG, 1/8" PIPE	8.01.01.00009039
40	VALVE, PILOT	3.97.01.00000501
41	ASSY. MANIFOLD	8.01.25.36010200
42	ELBOW, 3/4" FEMALE 90 DEG.	2.80.12.00003425
43	ELBOW, 3/4" MALE AND FEMALE 90 DEG.	2.80.12.00003426
44	PIPE, 3/4" X 25" SCH 40	8.01.25.00000021
45	VALVE, PRESSURE REGULATOR	2.80.41.00000048
46	ASSY., REAR BRUNER GAS INPUT	8.01.25.00000300
47	ASSY., PILOT TIP	8.01.25.00000400
48	ASSY., FRONT BURNER GAS INPUT	8.01.25.00000200
49	ASSY., BURNER HANGER	8.01.25.00000100
50	ASSY., OVEN BACK LINING	8.01.25.36001900
51	NUT, 1" x 8mm x 3/4"UNF	8.02.06.00004550

30	MPQ&C FMMB*1 15 L?RE?Q RMN @SPL CP	8.27.05.04826265
	ORIFICE HOOD, #51 LPG GAS TOP BURNER	8.27.05.04826170
53	BURNER, TOP	8.01.06.01000004
54	LOCKER, OVEN BOTTOM LINING ASSY.	8.01.38.00000024
55	ASSY., LEFT SIDE LINING	8.01.38.00140001
56	DOOR, RIGHT HOOK OVEN	4.02.05.00012854
57	THERMOCOUPLE	2.80.11.00044318
	ORIFICE HOOD, #41 NAT GAS OVEN BURNER	8.27.05.04826245
36	ORIFICE HOOD, #53 LPG GAS OVEN BURNER	8.27.05.04826150
59	LIGHTER	8.09.03.00002121
60	PILOT, LEFT OVEN MAINTUBE	8.01.25.00000900
61	OVEN, MAINTUBE	8.01.25.00000600
62	LINING, OVEN TOP	8.01.25.36000013
63	FIXER, REST PLACE	8.01.25.00000006
64	HANDLE, OVEN DOOR	8.01.25.24000100
65	PAN, GRIDDLE DRIP	8.01.25.36010002
66	TAG, IDENTIFICATION	2.90.03.21031707
67	ASSY., GRIDDLE PLATE	8.01.25.36000500
68	FITTING, 1/2" x 3/8" WIRES P/ IN.	8.27.05.00009056
	ORIFICE HOOD, #37 NAT GAS OVEN BURNER	8.27.05.04826265
47	ORIFICE HOOD, #52 LPG GAS OVEN BURNER	8.27.05.04826160
70	PIPE, 3/4" X 5" SCH 40	8.01.25.00000056
71	PROTECTION, HEAT	8.01.25.36000020
72	PILOT, RIGHT OVEN MAINTUBE	8.01.25.00000700
73	ASSY., GRIDDLE PLATE PILOT TIP	8.01.25.00000800
74	PROTECTION, INTERNAL HEAT	8.01.25.36000019
75	ASSY., GREASE CHUTE	8.01.25.36001800
ED	NIPPLE, 1/8" NPT X 7/16"	2.80.31.00004633

## INDEX

1. DEAR USER	3
2. IMPORTANT NOTES	3
3. BEFORE USING THE EQUIPMENT FOR THE FIRST TIME	3
4. INSTALLATION INSTRUCTIONS	4
5. OPERATION	9
6. MAINTENANCE	9
7. TECHNICAL DATA S240/S360	12
8. EXPLODED VIEW DRAWING S240/S360	13
9. PARTS LIST S240/S360	14
10. TECHNICAL DATA S36-24-2	15
11. EXPLODED VIEW DRAWING S36-24-2	16
12. PARTS LIST S36-24-2	17
WARRANTY TERM	18

## 1. DEAR USER

The RANGES are developed and manufactured in order to offer the user the best in the market in equipment for snack bars, restaurants and kitchens in general. To ensure this quality, which translates into efficiency, in addition to a carefully designed and meticulously tested design, the components are always the most appropriate, resulting in a cost-benefit equation that is always positive for the user.

***We recommend that you read this manual carefully. If in doubt, consult it. This will certainly help you to always have the best performance and safety when using your equipment!***

## 2. IMPORTANT NOTES

- \* **ATTENTION:** This equipment is intended for commercial / professional use.
- \* Please keep this manual with care. It is and will be very helpful when in doubt. Check it out.
- \* Installation must be carried out according to the manufacturer's instructions and by qualified and authorized persons.
- \* For repairs only, contact an authorized service technician and ask for original spare parts.
- \* Failure to comply with the warnings contained in this manual may jeopardize the operator's safety.
- \* The manufacturer reserves the right to modify the contents of this manual at any time without prior notice.
- \* The equipment should not be operated without the presence of a qualified person.
- \* This appliance is not intended for use by persons (including children) with reduced physical, sensory or mental capabilities or by persons lacking experience and knowledge, unless instructed to use the appliance or under the supervision of Person responsible for their safety.
- \* Make sure children do not play with the equipment.
- \* Daily hygienic product after use using neutral detergent, do not use abrasive materials. Never use water jets to clean the product.
- \* This equipment is to be installed on flooring materials that are corrosion resistant and cleanable. Flooring materials meeting these requirements would include masonry materials.

## 3. BEFORE USING THE EQUIPMENT FOR THE FIRST TIME

For the protection of the equipment against possible damages caused by humidity between the manufacture and the installation in the establishment, the grates are covered with a layer of vegetal fat, where it must be removed and carried out the cleaning with the aid of a sponge, neutral soap and water in small quantity.

After this procedure, turn on the burners and leave them on for about 10 (ten) minutes. This will cause all grid residues to be burned and disposed of. Only after that will the equipment be ready for use.

## 11. EXPLODED VIEW DRAWING - S36-24-2

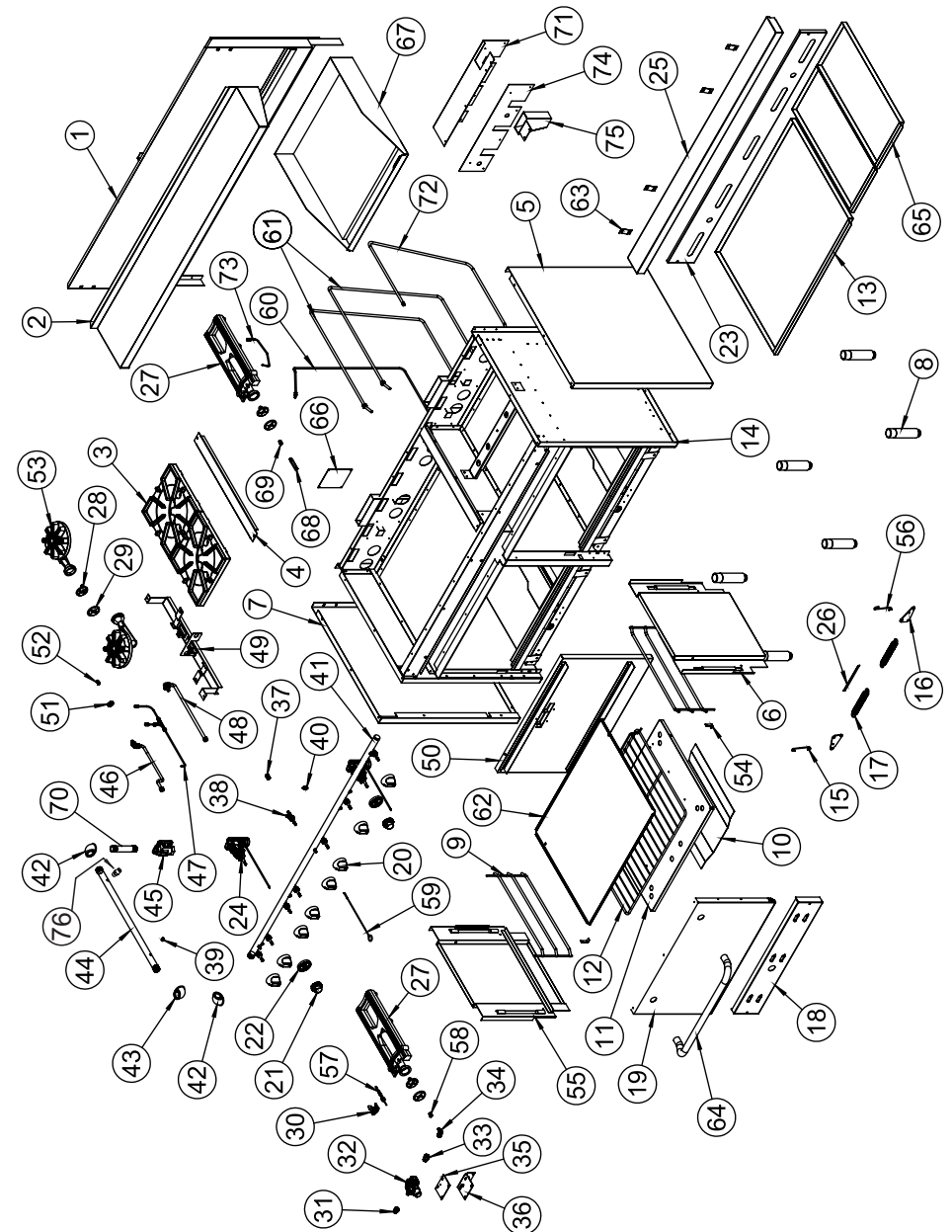

**10. TECHNICAL DATA - S36-24-2**

RCAFL A? J B? R?	
F CÆ FR d -k k	360j & 27. '
WIDTH in/mm	4. 0& 302'
DEPTH in/mm	1. 0ç 853'
DEPHT WITH OPEN DOOR in/mm	220& / / 4'
WEIGHT lbs/kg	620 & 60'
TOP BURNERS	4
TOP PILOT	4
GRIDDLE BURNER	0
GRIDDLE PILOT	0
OVEN BURNER	0
OVEN PILOT	0
MAXIMUM POWER NAT	050,.. .
MAXIMUM POWER LPG	054,.. .

**4. INSTALLATION INSTRUCTIONS**
**THIS APPLIANCE IS INTENDED FOR OTHER THAN HOUSEHOLD USE**

All BakeMax commercial gas appliances are manufactured by skilled craftsman using the finest quality materials.

PROPER installation by qualified personnel is essential for safe, efficient, and trouble-free operation of the unit. Any alteration and/or tampering, without proper knowledge, tools, and test equipment, is DANGEROUS and will void all warranties. The installation must conform with local codes, or in the absence of local codes, with the National Fuel Gas Code, ANSI Z223.1 - latest edition.

**PRESSURE TESTING: FAILURE TO INSTALL PRESSURE REGULATOR WILL VOID WARRANTY**

(Most units have a convertible regulator.) The appliance and its individual shut-off valve must be disconnected from the gas supply piping system during any pressure testing of that system at test pressure in excess of 1/2 psig (3.45 kPa). The appliance must be isolated from the gas supply piping system by closing its individual manual shut-off valve during any pressure testing of the gas supply piping system at test pressures equal to or less than 1/2 psig (3.45 kPa).

**NOTICE**

The proper installation of this gas appliance is the total responsibility of the end user. It is the responsibility of the purchaser to determine that the installer is qualified in installation procedures. Conversion, connecting gas lines, calibrating thermostats, burners, lighters, setting gas pressure with manometer, and etc., is all part of normal installation and will not be paid for under warranty. If a warranty technician is called out and finds the unit improperly installed, the end user may be subject to billing.

FOR MAINTENANCE, SERVICE, REPAIRS, OR INSTALLATION - Contact your dealer or the factory, for your local Factory Authorized Service Agency.

The gas pressure regulator provided with the equipment must be installed when the appliance is connected to the gas supply.

The area around the appliance must be kept free and clear of combustibles such as solvents, cleaning liquids, brooms, rags, etc.

Proper clearances must be provided at the front of the appliances for servicing and proper operation.

Provisions shall be incorporated in the design of the kitchen, to ensure an adequate supply of fresh air and adequate clearance for air operanings into the combustion chamber, for proper combustion and ventilation.

For proper operation of the appliance, do not obstruct the flow of combustion and ventilation air.

The installation must conform with local codes, or in the absence of local codes, with the national fuel gas code, ANSI Z223.1 - 1988 (or latest addenda).

The gas supply line must be at least 3/4" NPT.

## INSTALLATION - GAS STANDARDS AND CODES

**IMPORTANT** - The installation of this appliance must conform to local codes or, in the absence of local codes, with the National Fuel Gas Code ANSI Z223.1, Natural Gas Installation Code, CAN/CGA-B149-1, or the Propane Installation Code, CAN/CGA-B149-2 as applicable, including:

1. The appliance and its individual shut off valve must be disconnected from the gas supply piping system during any pressure testing of that system at test pressure in excess of 1/2 psi (3.45 kPa).
2. The appliance must be isolated from the gas supply piping system by closing the individual manual shut-off valve during any pressure testing of the gas supply piping system at test pressures equal to or less than 1/2 PSI.

**GAS CONNECTION-** The gas inlet line size of this appliance is 3/4" NPT. For proper operation, the gas supply service line must be the same size or greater than the inlet line size of the appliance. The gas line size must not be reduced at any point along the supply line.

**MANUAL SHUT - OFF VALVE-** A gas pressure regulator and a contractor-supplied shut-off valve must be plumbed in the gas service line ahead of the appliance – in a physical location where it can be reached quickly in the event of an emergency.

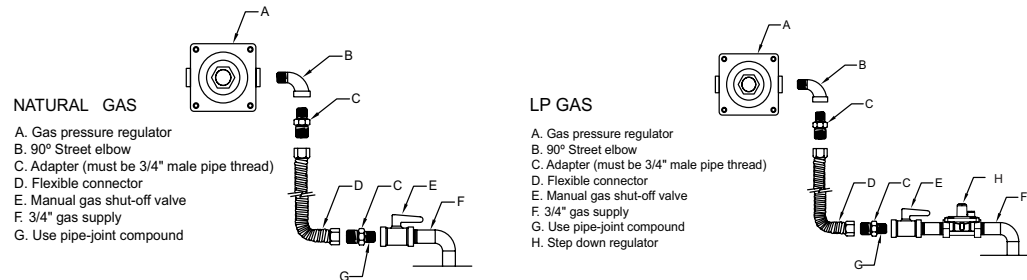

When installing the pressure regulator - remember it can only handle 1/2 PSI. In every LPG installation, you have high source pressures, ranging from 20 PSI to 100 PSI. If the high pressure gas line from the LPG tank is directly connected to the unit without the proper step-down regulator, it will rupture the diaphragm in the valve, rendering it useless.

Visually double check any installer-supplied intake pipes and/or blow them out using compressed air to clear any dirt or debris, threading chips, or other foreign matter – before installing a service line.

Those particles will clog gas orifices when gas pressure is applied. Compounds used on threaded joints of this appliance piping must be resistant to the action of NG and LP gas and provide a gas tight seal to prevent leaks.

The gas pressure regulator must be installed in the gas line – failure to install a pressure regulator will void the equipment warranty. The regulators supplied with ranges have 3/4" NPT connections; the regulator is adjusted at the factory for 4" W.C. (water column) manifold gas pressure (natural gas) or 10" W.C. manifold gas pressure for propane gas operation.

## 9. PARTS LIST - S240 - S360

PARTS LIST			
S240/S360			
ITEM	DESCRIPTION	MODEL	CODE
1	ASSY., BACK SPLASHER	S240	8.01.25.24000500
		S360	8.01.25.36000600
2	SHELF	S240	8.01.25.24000015
		S360	8.01.25.06000053
3	GRATE, TOP	ALL MODELS	8.01.06.01000006
4	SUPPORT, TOP GRATE	ALL MODELS	8.01.25.06000016
5	RIGHT SIDE	ALL MODELS	8.01.25.06000011
6	ASSY., RIGHT SIDE LINING	ALL MODELS	8.01.38.00130001
7	LEFT SIDE	ALL MODELS	8.01.25.06000066
8	ASSY., LEG	ALL MODELS	8.01.25.00000500
9	RACK, SIDE LINING	ALL MODELS	4.02.05.02100585
10	DEFLECTOR, OVEN	ALL MODELS	8.01.25.00000040
11	ASSY., OVEN BOTTOM LINING	S240	8.01.25.24000600
		S360	8.01.25.36000700
12	GRIDDLE, OVEN	S240	4.02.07.00550490
		S360	4.01.06.05500790
13	DRIP PAN	S240	8.01.25.24010001
		S360	8.01.25.36010001
14	ASSY., BODY	S240	8.01.25.24000700
		S360	8.01.25.36000800
15	DOOR, LEFT HOOK OVEN	ALL MODELS	4.02.05.00012899
16	SPRING DRIVE	ALL MODELS	8.01.38.00070002
17	SPRING, OVEN DOOR	ALL MODELS	4.02.05.00012853
18	PANEL, LOWER	S240	8.01.25.24010003
		S360	8.01.25.36010005
19	ASSY., DOOR	S240	8.01.25.24000800
		S360	8.01.25.36000900
20	KNOB	ALL MODELS	4.03.04.17031401
21	KNOB, OVEN	ALL MODELS	8.97.01.00221029
22	BEZEL, OVEN KNOB	ALL MODELS	8.97.01.01221029
23	APRON	S240	8.01.25.24010002
		S360	8.01.25.36010004
24	THERMOSTAT, ABJC VALVE	ALL MODELS	8.97.01.00057579
25	REST, PLATE	S240	8.01.25.24000005
		S360	8.01.25.06000018
26	COUPLING, SPRING	S240	8.01.25.04000050
		S360	8.01.38.06000015
27	OVEN BURNER	ALL MODELS	8.01.06.01000007
28	AIR SHUTTER, INTERNAL	ALL MODELS	8.01.25.00000015
29	AIR SHUTTER, EXTERNAL	ALL MODELS	8.01.25.00000014
30	PILOT, OVEN	ALL MODELS	4.01.01.00000201
31	ELBOW, 3/8"NPT x 5/8"UNEF	ALL MODELS	8.01.25.00009046
32	VALVE, SAFETY	ALL MODELS	8.97.01.00001502
33	FITTING, 3/8"NPT	ALL MODELS	8.01.25.00009053
34	ELBOW, 3/8"NPT x 3/8"	ALL MODELS	8.01.25.00009043
35	FIXER, SAFETY VALVE	ALL MODELS	8.01.25.00000041
36	SUPPORT, SAFETY VALVE	ALL MODELS	8.01.25.00000047
37	REDUCTION, 5/8" x 22mm x 1/8"NPS	ALL MODELS	2.80.29.00004635
38	VALVE, GAS MANUAL	ALL MODELS	3.97.01.00000500
39	PLUG, 1/8" PIPE	ALL MODELS	8.01.01.00009039
40	VALVE, PILOT	ALL MODELS	3.97.01.00000501

41	ASSY. MANFOLD	S240	8.01.25.24010100
		S360	8.01.25.36010100
42	ELBOW, 3/4" FEMALE 90 DEG.	ALL MODELS	2.80.12.00003025
43	ELBOW, 3/4" MALE AND FEMALE 90 DEG.	ALL MODELS	2.80.12.00003026
44	PIPE, 3/4" X 25" SCH 40	ALL MODELS	8.01.25.00000021
45	VALVE, PRESSURE REGULATOR	ALL MODELS	2.80.41.00000048
46	ASSY., REAR BRUNER GAS INPUT	ALL MODELS	8.01.25.00000030
47	ASSY., PILOT TIP	ALL MODELS	8.01.25.00000040
48	ASSY., FRONT BRUNER GAS INPUT	ALL MODELS	8.01.25.00000020
49	ASSY., BURNER HANGER	ALL MODELS	8.01.25.00000100
50	ASSY., OVEN BACK LINING	S240	8.01.25.24000900
		S360	8.01.25.36001000
51	NUT, 1" x 8mm x 3/4"UNF	ALL MODELS	8.02.06.00000450
52	ORIFICE HOOD, #37 NAT GAS TOP BURNER	S240	8.27.05.04826285
		S360	8.27.05.04826286
53	BURNER, TOP	ALL MODELS	8.01.06.01000004
54	LOCKER, OVEN BOTTOM LINING ASSY.	ALL MODELS	8.01.38.00000024
55	ASSY., LEFT SIDE LINING	ALL MODELS	8.01.38.00140001
56	DOOR, RIGHT HOOK OVEN	ALL MODELS	4.02.05.00012854
57	THERMOCOUPLE	ALL MODELS	2.80.11.00044318
58	ORIFICE HOOD, #41 NAT GAS OVEN BURNER	S240	8.27.05.04826245
		S360	8.27.05.04826150
59	ORIFICE HOOD, #37 NAT GAS OVEN BURNER	S240	8.27.05.04826285
		S360	8.27.05.04826150
59	ORIFICE HOOD, #51 LPG GAS OVEN BURNER	ALL MODELS	8.08.03.00002121
59	LIGHTER	ALL MODELS	8.01.25.00000000
60	PILOT, OVEN MAINTUBE	ALL MODELS	8.01.25.00009000
61	OVEN, MAINTUBE	ALL MODELS	8.01.25.00000600
62	LINING, OVEN TOP	S240	8.01.25.24000016
		S360	8.01.38.06000014
63	FIBER, REST PLATE	ALL MODELS	8.01.25.00000006
64	HANDLE, OVEN DOOR	S240	8.01.25.24000100
		S360	8.01.25.36000100
65	TAG, IDENTIFICATION	ALL MODELS	2.90.03.21031707
66	PIPE, 3/4" X 5" SCH 40	ALL MODELS	8.01.25.00000056
00	NIPPLE, 1/8" NPT X 7/16"	[[ [ a h 9 ] [ ]	CBCECCCECCCECC

## 8. EXPLODED VIEW DRAWING - S240 - S360

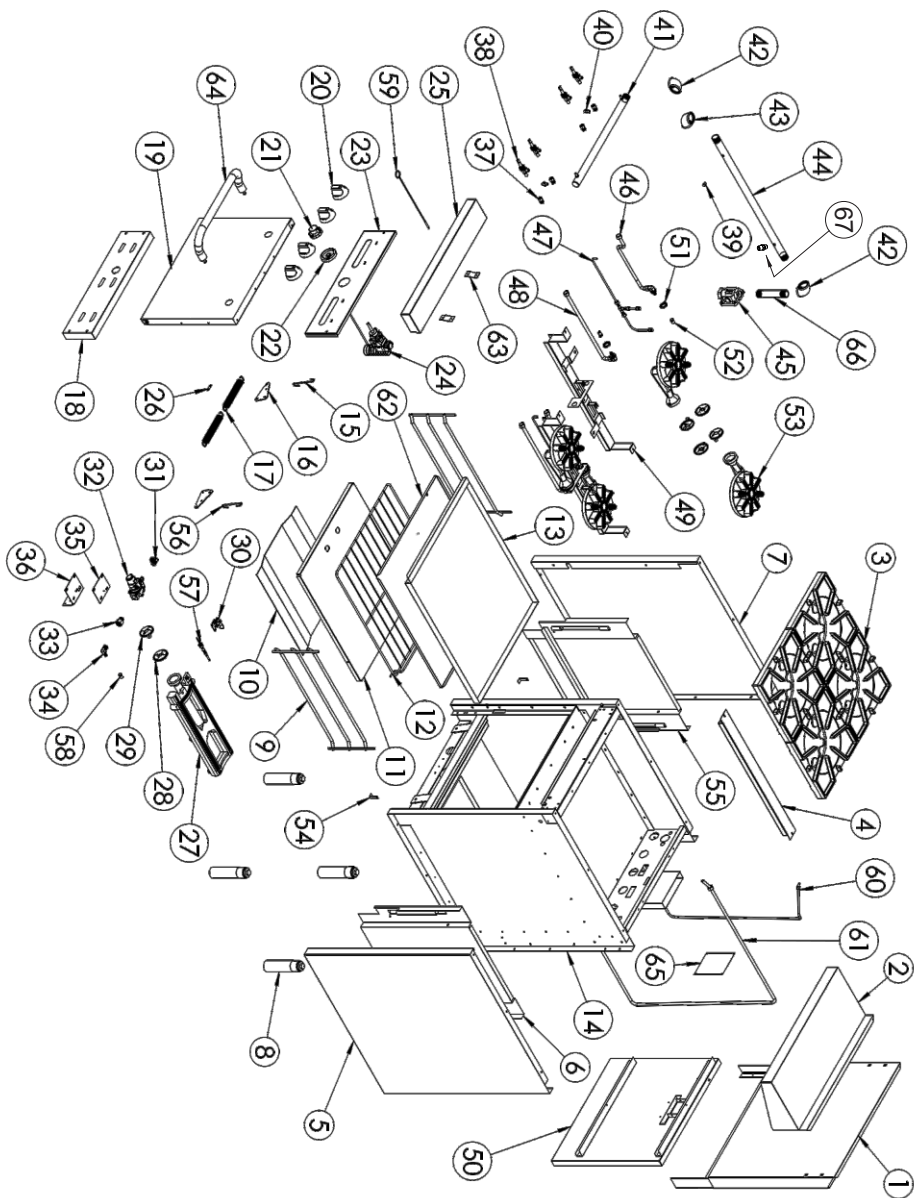

Before connecting the regulator, check the incoming line pressure – as these regulators can only withstand a maximum inlet pressure of 14" W.C. (1/2 PSI); exceeding this pressure will damage them. If the gas supply line pressure is greater than this amount, a step-down regulator will be required.

A gas flow direction arrow is cast into the body of the regulator to minimize installation error – it should point downstream to the appliance. The blue air vent cap on the top of the regulator is part of the regulator and should not be removed.

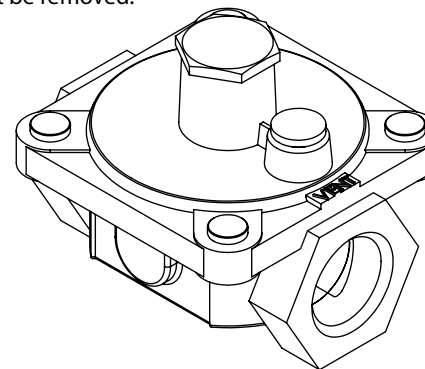

Any adjustment to the regulator must be made only by qualified and licensed service personnel with the proper calibrated test equipment. Gas connections should be performed by a qualified licensed contractor.



**WARNING**

In the event of a power failure, no attempt should be made to operate the unit during power failure.

## OPERATING INSTRUCTIONS

*Before lighting, check all joints in the gas supply line for leaks. Do not use an open flame to check for leaks! Use soap and water solution.*

1. Turn pilot valves to OFF position by turning adjustment screws clockwise.
2. Turn ON the manual gas valve at the inlet side of the gas supply line.
3. Check for gas leaks at the flexible coupling or gas connector fitting using a solution of one part soap and three parts water.
4. Sparingly spray or brush the soapy solution at the gas fittings; active bubbling indicates location of gas leak.
5. If a gas leak is detected turn off the manual gas valve at the inlet side of the gas line. Call your certified and licensed service technician.
6. Turn pilot adjustment screw counter-clockwise, then light standing pilot and adjust flame 1/4" high.
7. Turn ON gas valve/thermostat to light main burners.
8. For complete shut down, shut off gas valves and turn pilot adjustment screw clockwise to shut off gas to the pilots.

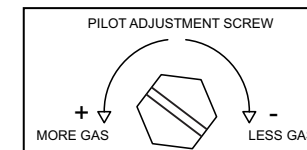

## PROPANE GAS CONVERSION INSTRUCTIONS

A griddle is equipped with fixed orifice hoods and shipped from the factory for use on natural gas.

To convert to propane gas, install the propane burner orifice hoods supplied as follows:

- 1 - Remove the griddle plate by lifting with two people and set a side.
- 2 - Slide the burners back off of the valve orifice hoods a couple of inches and let it rest.
- 3 - Remove the natural gas orifice hoods with a 1/2" wrench.
- 4 - Apply a very little bit of pipe dope on the threads of the valve.

**DO NOT APPLY PIPE DOPE INTO ORIFICE HOOD.**

- 5 - Attach the supplied propane burner orifice hoods with a 1/2" wrench.
- 6 - Convert the pressure regulator from Natural to Propane gas by inverting the snap-in device beneath the cap on the regulator. This will require a fair amount of pressure. Do not remove the spring. When replacing the cap make sure the snap-in insert goes down on top of the middle of the spring.
- 7 - Test for proper pressure; 10" W.C. (water column) using a manometer.
- 8 - Slide burners back onto the orifice hoods.
- 9 - Apply the Propane "Notice" sticker to the front of the unit for future reference.

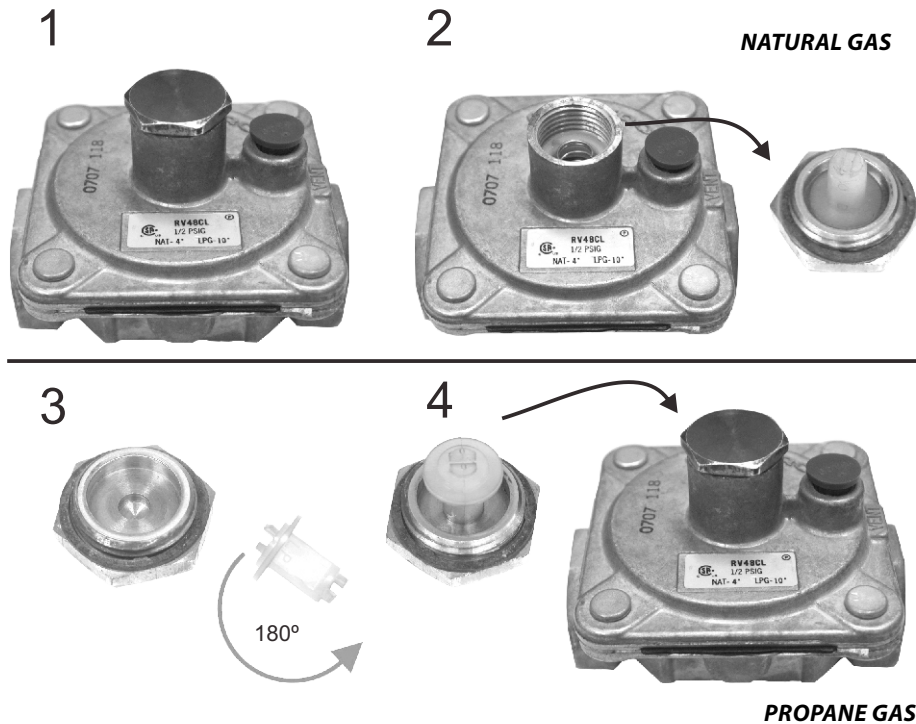

## 7. TECHNICAL DATA - S240

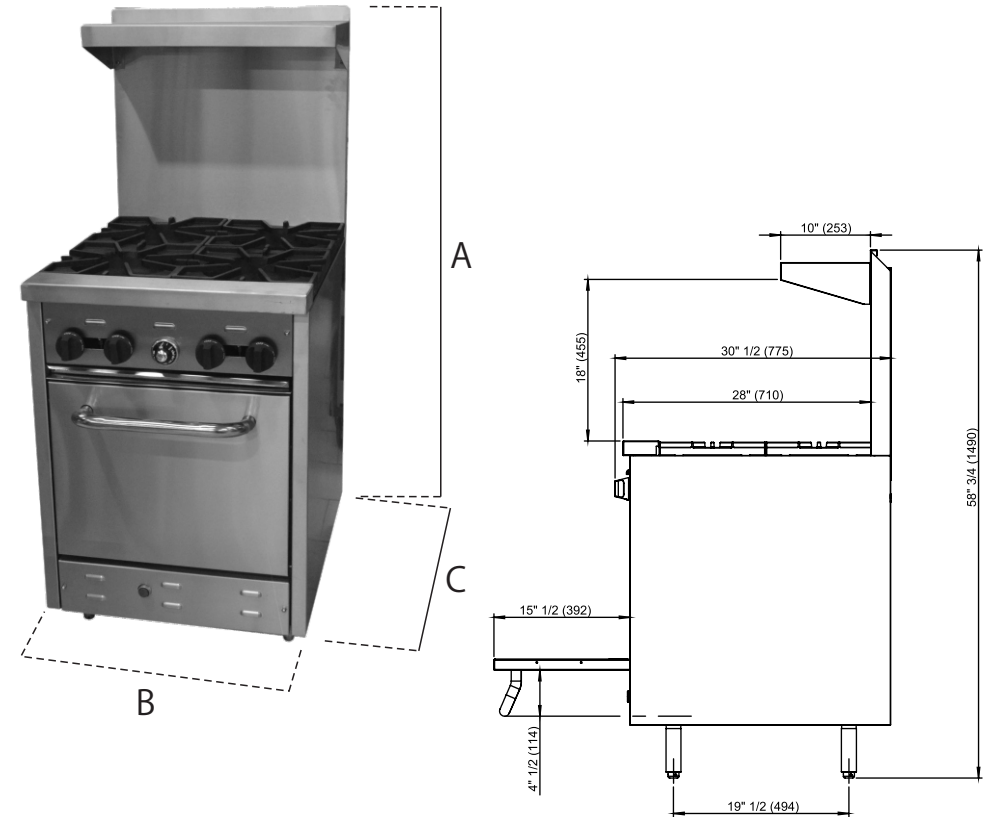

	RCAFL @ J B ? R?	
KMBCJ	S240	S360
HEIGHT in/mm	36 1/2 & 27.1	
WIDTH in/mm	24" (609)	36" (914)
DEPTH in/mm	1. 0 1/2 & 53'	
DEPHT WITH OPEN DOOR in/mm	22 1/2 & 11 1/4'	
WEIGHT lbs/kg	375 (170)	478.4 (217)
TOP BURNERS	4	6
TOP PILOT	4	6
OVEN BURNER	1	1
OVEN PILOT	1	1
MAXIMUM POWER NAT	145.000	210.000
MAXIMUM POWER LPG	147.000	210.000



**TO REPAIR, TO GET ACESS, FOLLOW THE INSTRUCTIONS**

Turn the oven bottom lining assembly locker 90°  
Lift and take off the oven bottom lining assembly

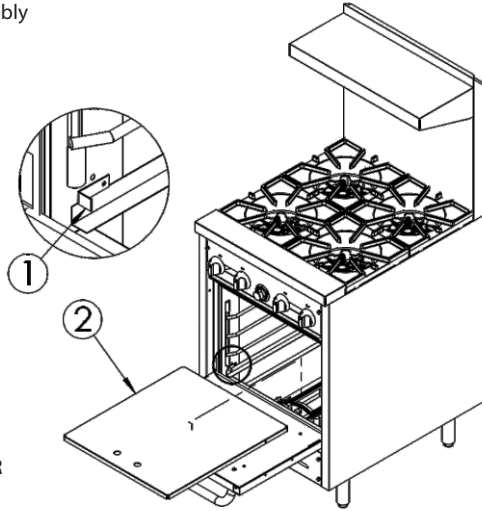

1 - OVEN BOTTOM LINING ASSEMBLY LOCKER  
2 - OVEN BOTTOM LINING ASSEMBLY

Take off the rest plate fixer screws  
Take off the rest plate  
Lift and take off the griddle plate

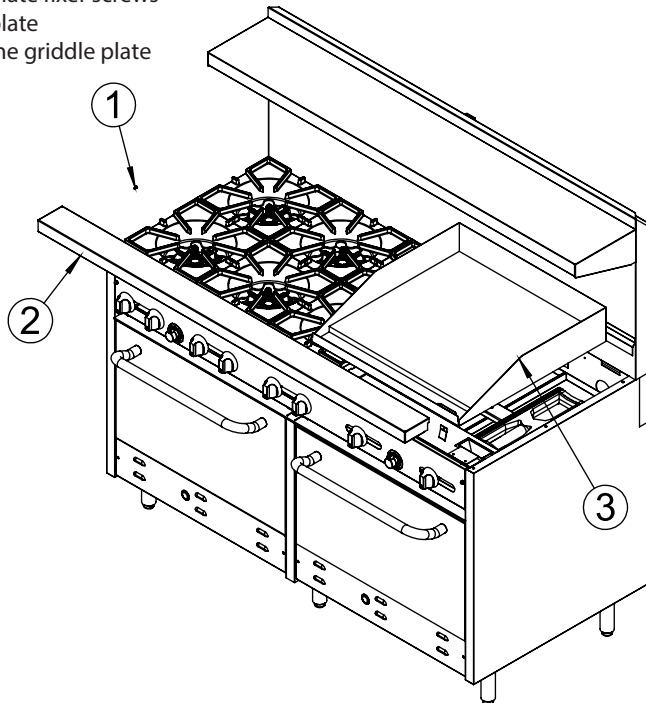

1 - SCREW  
2 - REST PLATE  
3 - GRIDDLE PLATE

**INSTALLING THE BACKSLASH OR HIGH SHELF:**

To install a backslash or high shelf on a BakeMax Range, proceed as follows:

1. Ensure back of unit is easily accessible.
2. If mounting low back (backslash), slide into supports on back of unit, and secure with #10 x 5/8" sheet metal screws.
3. If mounting high shelf, mount shelf to high back using #24 x 3/4" machine screws with nut and washer.
4. Slide backslash into the side-supports on back of unit, and secure with #10 x 5/8" sheet metal screws.

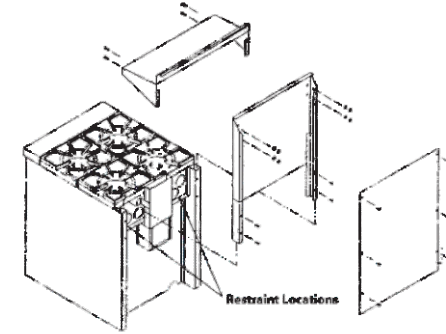

**HOOK-UP PROCEDURE FOR COMBINATION UNITS:**

Units prefixed with a "2" may be shipped separately. For connection, set the units side by side. Install backslash. Install hook-up strip in the front center of the two units. Ensure that everything is aligned properly. Install and tighten all screws.

**HANDLE ASSEMBLE**

Adjust the handle at the door assembly.  
Fix the screws.

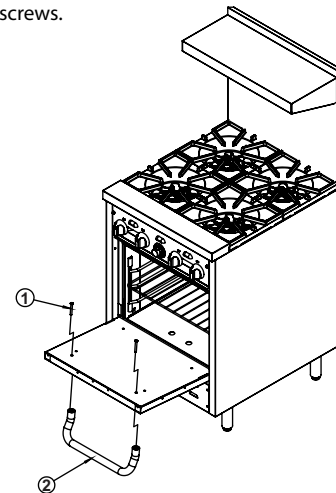

1 - SCREW  
2 - HANDLE

**KNOB ASSEMBLE**

Plug the knob at the gas valve.

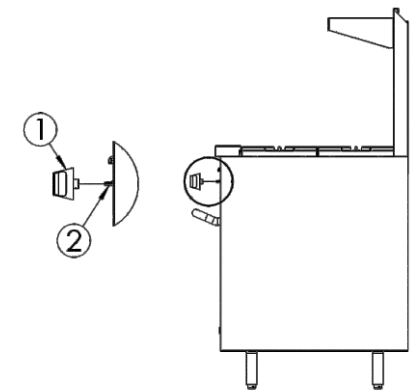

1 - KNOB  
2 - GAS VALVE

## 5. OPERATION

### OVEN

1. Turn thermostat to the OFF position.
2. Wait five minutes.
3. Access the burner compartment by lifting up the kickplate and rotating forward to expose the safety valve.
4. Push in and hold the safety valve button at the bottom of the oven.
5. Light the pilot by repeatedly pressing the piezo electric ignition button; keep safety valve button pressed in until the pilot stays lit when released.
6. If pilot goes out repeat steps 2-5.
7. Set thermostat to desired temperature.
8. Turn the thermostat to the OFF position for complete shut down; shut-off main gas valve.

### IGNITION

To perform the correct ignition of the burners, follow the steps below:

- 1 - Soak the lighter (wick) that accompanies the product in alcohol and light it;
- 2 - Rotate the manipulator corresponding to the burner you want to turn 90° counterclockwise;
- 3 - Insert the igniter (wick) into the hole corresponding to the ignition located on the panel, until you pass the hole in the burner plate;
- 4 - Make sure that the burner is lit. If the burner does not light up, repeat the procedure;
- 5 - Remove the igniter (wick) and do the same with the other burners (the order of ignition does not interfere with the use of the equipment);

OPERATION: The flames of the burners will heat the baffles (plates), which will radiate the heat with uniformity for the food placed on the grates.

## 6. MAINTENANCE

Like any other piece of equipment, the unit must be cleaned on a regular basis.

**CAUTION: FOR YOUR PROTECTION:** This is commercial cooking equipment. It should be kept in mind that when in operation, the surface temperature will exceed that of equipment designed for household use. Always maintain the proper clearance as specified in the table cited under General Information. If the unit is restrained, the operator should be aware of how the unit is restrained. The operator should be familiar with how to connect and disconnect the restraints. If the restraint is removed for service or maintenance, the restraint must be reconnected prior to putting the unit back into service.

**NEVER** attempt to move or slide the unit when hot.

**ALWAYS** let the unit cool down and empty the grease drawer prior to any attempt to relocate or move the unit.

**NEVER** move or transport the unit when the unit is hot.

### TO CLEAN THE EXTERIOR: (Stainless Steel)

1. Let it cool down. Normal daily soil can be removed with a mild detergent or soap solution applied with a damp cloth. Rinse and dry thoroughly.
2. To remove baked-on grease, apply a cleanser in the direction of the polish lines on the metal. NEVER rub in a circular motion. Scotch Brite or Stainless Steel scouring pads may be used on tough or burnt-on deposits that do not respond to the procedure above.

### TO CLEAN THE OVEN/RANGE INTERIOR:

1. Allow the oven/range interior to cool, completely. Use a nonalkaline based cleaning agent, following the recommendations of the manufacturer. DO NOT use abrasives. Oven cleaner may be used on surfaces which have porcelain enameling.
2. Rinse thoroughly with cool, clean water. Dry thoroughly. Clean daily or as needed.
3. Should the pilot be extinguished, follow the Lighting Instructions.

To reduce down time and for maximum efficiency, have your appliance serviced once or twice a year, depending on the amount of usage. Have a technician:

- Examine the appliance venting system at least twice a year.
- Clean and adjust burners, lighters, regulators, and etc. twice a year.
- Check and calibrate the thermostats and the manifold pressure at least once a year.
- Regrease manual control valves. Call factory for service bulletin.

### TO REPAIR, TO GET ACCESS, FOLLOW THE INSTRUCTIONS

- 1 - Lift the top grates
- 2 - Take off the rest plate fixer screws
- 3 - Take off the rest plate
- 4 - Take off the knobs
- 5 - Take off the panel fastening screws
- 6 - Take off the panel
- 7 - Take off the lower panel fastening screws
- 8 - Take off the lower panel

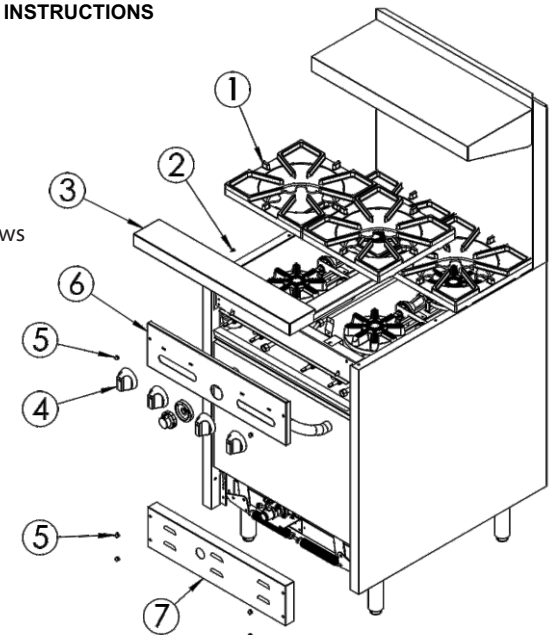

- 1 - TOP GRATE
- 2 - REST PLATE FIXER SCREW
- 3 - REST PLATE
- 4 - KNOB
- 5 - PANEL SCREW
- 6 - PANEL
- 7 - LOWER PANEL