



## INDOOR/OUTDOOR KEGERATOR



**Models:**

**SBC682    LBC243T    BC3T    WBC3F**  
**SBC683OS    LBC24OS    BC74OS    WBC3ZOS**

### *User Manual*

**BEFORE USE, PLEASE READ AND FOLLOW ALL SAFETY RULES AND OPERATING INSTRUCTIONS**

Write Serial Number here:

\_\_\_\_\_

**Felix Storch, Inc.**  
**An ISO 9001:2015 registered company**  
**770 Garrison Avenue**  
**Bronx, NY 10474**  
**[www.summitappliance.com](http://www.summitappliance.com)**

# TABLE OF CONTENTS

<b>Appliance Safety</b>	<b>3</b>
<b>Important Safeguards</b>	<b>3-4</b>
<b>Installation Instructions</b>	<b>5-6</b>
<i>Before Using your Appliance</i>	5
<i>Installation of your Appliance</i>	5
<i>Reversing the Door Swing</i>	5
<i>Installation of the Guard Rail (Optional)</i>	6
<i>Installation of Casters (Optional)</i>	6
<i>Installation of the Tap Cooled System</i>	6
<i>Shelves</i>	6
<i>Interior Strap</i>	6
<b>Operation</b>	<b>7-8</b>
<i>Control Panel</i>	7
<i>Defrosting</i>	7-8
<b>Care and Maintenance</b>	<b>8</b>
<i>Cleaning your Appliance</i>	8
<i>Power Failure</i>	8
<i>Vacation Time</i>	8
<i>Transporting your Appliance</i>	8
<i>Energy-Saving Tips</i>	8
<b>Troubleshooting</b>	<b>9</b>
<b>Limited Warranty</b>	<b>10</b>

**CALIFORNIA CARB/SNAP DISCLOSURE**

This product uses eco-friendly hydrocarbon refrigerant and fully complies with California CARB regulations.

However, we are required by California Law to provide the following disclosure statement in every product sold in California.

*"This equipment is prohibited from use in California with any refrigerants on the 'List of Prohibited Substances' for that specific end-use, in accordance with California Code of Regulations, title 17, section 95374. This disclosure statement has been reviewed and approved by Felix Storch, Inc. and Felix Storch, Inc. attests, under penalty of perjury, that these statements are true and accurate."*

This product does not use any refrigerants on the 'List of Prohibited Substances'"

# APPLIANCE SAFETY

**Your safety and the safety of others are very important.**

We have provided many important safety messages in this manual and on your appliance. Always read and obey all safety messages.



This is the Safety Alert Symbol. The symbol alerts you to potential hazards that can kill or injure you and others. All safety messages will follow the Safety Alert Symbol and either the words DANGER or WARNING.



DANGER means that failure to heed this safety statement may result in severe personal injury or death.



WARNING means that failure to heed this safety statement may result in extensive product damage, serious personal injury, or death.

All safety messages will alert you about the potential hazard, tell you how to reduce the chance of injury, and let you know what can happen if the instructions are not followed.

---

## IMPORTANT SAFEGUARDS



Before the appliance is used, it must be properly positioned and installed as described in this manual, so read the manual carefully. To reduce the risk of fire, electrical shock or injury when using the appliance, follow basic precautions, including the following:



- Plug into a grounded 3-prong outlet. Do not remove grounding prong, do not use an adapter, and do not use an extension cord.
- It is recommended that a separate circuit, serving only your appliance, be provided. Use receptacles that cannot be turned off by a switch or pull chain.
- Never clean appliance parts with flammable fluids. These fumes can create a fire hazard or explosion.
- Before proceeding with cleaning and maintenance operations, make sure the power line of the unit is disconnected.
- Do not connect or disconnect the electric plug when your hands are wet.
- Unplug the appliance or disconnect the power before cleaning or servicing. Failure to do so can result in electrical shock or death.
- Do not attempt to repair or replace any part of your appliance unless it is specifically recommended in this manual. All other servicing should be referred to a qualified technician.
- Do not store or use gasoline or any other flammable vapors and liquids in the vicinity of this or any other appliance. The fumes can create a fire hazard or explosion.
- Use two or more people to move/install the appliance. Failure to do so can result in back or other injury.
- To ensure proper ventilation for your appliance, the front of the unit must be completely unobstructed. Choose a well-ventilated area with temperatures above 50°F (10°C) and below 100°F (37°C). This unit must be installed in an area protected from the elements, such as wind, rain, water spray or drips.
- The appliance should not be located next to ovens, grills or other sources of high heat.

- The appliance must be installed with all electrical connections in accordance with state and local codes. A standard electrical supply (115V AC only, 60 Hz), properly grounded in accordance with the National Electrical Code and local codes and ordinances, is required.
- Do not kink or pinch the power supply cord of the appliance.
- The fuse (or circuit breaker) size should be 15 amps.
- It is important for the appliance to be leveled in order to work properly. You may need to make several adjustments to level it.
- Although the unit has been tested at the factory, due to transit and storage, you should clean the appliance before use.
- Do not use solvent-based cleaning agents or abrasives on the interior. These cleaners may damage or discolor the interior.
- Do not use this apparatus for other than residential purposes.
- This appliance is CFC- and HFC-free and contains small quantities of Isobutane (R600a) which is environmentally friendly, but flammable. It does not damage the ozone layer, nor does it increase the greenhouse effect. Care must be taken during transportation and setting up of the appliance that no parts of the cooling system are damaged. Leaking coolant can ignite and may damage the eyes.
- In the event of any damage:
  - Avoid open flames and anything that creates a spark,
  - Disconnect from the electrical power line,
  - Air the room in which the appliance is located for several minutes, and
  - Contact the Service Department for advice.
- The more coolant there is in an appliance, the larger the room it should be installed in. In the event of a leakage, if the appliance is in a small room, there is the danger of combustible gases building up. For every ounce of coolant, at least 325 cubic feet of room space is required. The amount of coolant in the appliance is stated on the data plate on the back of the appliance. It is hazardous for anyone other than an authorized Service Person to carry out servicing or repairs to this appliance.
- Take serious care when handling, moving, and using the appliance to avoid either damaging the refrigerant tubing or increasing the risk of a leak.
- Replacing component parts and servicing shall be done by factory authorized service personnel so as to minimize the risk of possible ignition due to incorrect parts or improper service.

**⚠ DANGER ⚠**      ***Risk of child entrapment***

- Child entrapment and suffocation are not problems of the past. Junked or abandoned appliances are still dangerous, even if they will “just sit in the garage a few days”.
- **Before you throw away your old wine cooler or any appliance:**
  - Remove the door. Leave the shelves in place so that children may not easily climb inside.
  - Never allow children to operate, play with, or crawl inside the appliance.

**- SAVE THESE INSTRUCTIONS -**

# INSTALLATION INSTRUCTIONS

## Before Using Your Appliance

- Remove the exterior and interior packing.
- Before connecting the appliance to the power source, let it stand upright for approximately 2 hours. This will reduce the possibility of a malfunction in the cooling system from handling during transportation.
- Clean the interior surface with lukewarm water using a soft cloth.
- Install the handle on the left side of the door using the screws that are provided.

## Installation of Your Appliance

- This appliance is designed for free standing or built-in (fully recessed) installation. If free standing, the unit should have at least 4" of clearance at both sides, at the top and at the back to allow for adequate ventilation. If it is built-in, leave 3/16" at both sides, 1/16" at the top and 2" at the rear. Be sure that airflow under the appliance is not blocked.
- Place your appliance on a floor that is strong enough to support it when it is fully loaded. To level your appliance, adjust the front leveling legs at the bottom.
- Locate the appliance away from direct sunlight and sources of heat (stove, heater, radiator, etc.). Direct sunlight may affect the acrylic coating and heat sources may increase electrical consumption. Extremely cold ambient temperatures may also cause the unit not to perform properly.
- Avoid locating the unit in moist areas.
- Plug the appliance into an exclusive, properly installed and grounded wall outlet. Do not under any circumstances cut or remove the third (ground) prong from the power cord. Any questions concerning power and/or grounding should be directed toward a certified and authorized products service center.
- The handle is stored inside the unit. Install using the screws (supplied).

## Reversing the Door Swing

This appliance has the capability of the door opening from either the left or right side. Should you desire to reverse the opening direction, please follow the instructions below. To make the reversal, you will find two hardware pieces in a plastic bag inside the appliance: the top left hinge and the bottom left hinge. The bottom support bracket is used for both sides.

1. Carefully lay the appliance on its back. Use cushioning to protect the floor and appliance.
2. Using a Phillips screwdriver, remove the two screws and bottom right hinge beneath the door. Keep the hinge in a safe place in case you need to reverse the door again in the future.
3. Carefully slide the door off and place it on a padded surface.
4. Interchange the plastic shaft sleeves at the top of the door.
5. Remove the bottom support bracket from the right side.
6. Remove the top right hinge and keep in a safe place in case you want to reverse the door in the future.
7. Remove the screws from the top left and transfer to the right.
8. Install the top left hinge.
9. Install the bottom left hinge to the door. Do not over-tighten the screw.
10. Place the door back on the appliance, lining up the top hinge.
11. Install the bottom support bracket.
12. Adjust door alignment. When set, tighten screw on hinge.
13. Remove handle. Transfer the screw hole covers to the left and install the handle on the right.

**NOTE:** Some door styles may not be reversible. Consult our website for details.

### Installation of the Guardrail (optional)

1. Place the guardrail on top of the kegerator and line up the feet with the holes on top of the cabinet
2. Using the screws provided, secure each foot to the cabinet

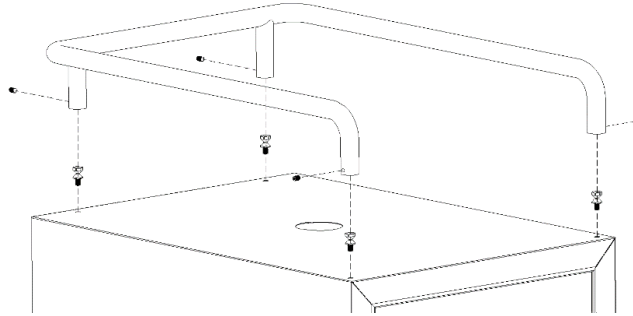

### Installation of the Casters (optional)

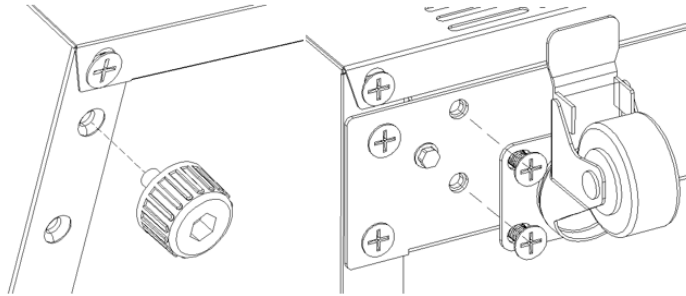

1. Remove everything from the cabinet and lay the unit on a clean, dry, and padded surface.
2. Remove the four feet at the bottom of the unit as shown, install caster into the holes and tighten with a Phillips screwdriver.
3. The two casters equipped with locks should be installed on the front of the unit.
4. Once all four casters are attached, return the kegerator to an upright position.
5. Allow the unit to sit for 8-10 hours before plugging in to allow the refrigerant to settle.

### Installation of Tap Cooled System

Your kegerator is equipped with a tap cooled system, which can keep the liquid in a single or double tap cool. NOTE: The tap cooling tube will not work for a triple tap system.

To install:

1. Remove the plug on the top of your kegerator.
2. Push the black tap cooling tube up through the top hole.
3. Install your tapping tower over the tube.

### Shelves

Your unit comes with two adjustable shelves, which can also be removed should you decide not to use them.

### Interior Strap

Use the strap located inside the unit to secure the CO<sub>2</sub> tank in place.

**NOTE:** Instructions for your tapping equipment (if included) are packaged inside the tap kit. These can be downloaded from the product page listing on our website at [www.summitappliance.com](http://www.summitappliance.com).

# OPERATION

- The appliance should be placed where the ambient temperature is between 10~38°C (50~100°F). If the ambient temperature is above or below this range, the performance of the unit may be affected. Placing your unit in extreme cold or hot conditions may cause interior temperatures to fluctuate.
- Connect power cord to a properly grounded outlet.
- This appliance is equipped with Memory IC – should there be a power interruption, unit will auto recover at last setting.

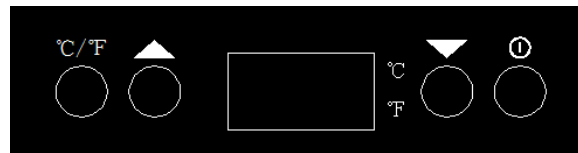

## Control Panel



### ON/OFF Power

To turn the appliance on or off, press and hold the ON/OFF button for 3 seconds.

### Setting the temperature Control

- Adjustable temperature: 1°C to 20°C (34°F to 68°F)
- Set the desired cooling temperature by pressing the corresponding button  or . Each depression of the buttons will raise or lower the temperature setting by 1 degree. The temperature selected will flash in the LED display for approximately 5 seconds, then revert back to displaying the temperature of the cabinet interior.

### °C/°F

This unit has the option of displaying temperatures in either Celsius or Fahrenheit. To change the setting, press the °C/°F button.

### **NOTES:**

- If the unit is unplugged, turned off or experienced a power failure, you must wait 3 to 5 minutes before restarting the unit. If you attempt to restart before this time delay, the appliance will not start.
- When you use the appliance for the first time, or restart after having been shut off for a long time, there could be a few degrees variance between the set temperature and the displayed temperature on the LED readout. This is normal and is due to the length of inactivity. Once the unit runs for a few hours, everything will be back to normal.

### **Defrosting**

- The unit defrosts automatically in normal operating conditions. The evaporator behind the rear wall of the unit defrosts automatically. The condensate collects in the drainage channel behind the rear wall of the unit, and flows through the drainage hole into the drip tray by the compressor where it evaporates.
- However, frost may accumulate on the evaporator if the unit is repeatedly opened in a high heat or high humidity location. If this frost pattern does not clear within 24 hours, your unit will require manual defrosting.

# CARE AND MAINTENANCE

## Cleaning Your Appliance

1. Turn off the power, unplug the appliance, and remove all items including shelves and racks.
2. Wash the inside surfaces with a warm water and baking soda solution. The solution should consist of about 2 tablespoons of baking soda to a quart of water.
3. Wash the shelves with a mild detergent solution.
4. Wring excess water out of the sponge or cloth when cleaning the area of the controls or any electrical parts.
5. Wash the exterior of the cooler with a warm solution of mild liquid detergent. Rinse well and wipe dry with a clean soft cloth.

## Power Failure

Most power failures are corrected within a few hours and should not affect the temperature of your appliance if you minimize the number of times the door is opened. If your power is going to be off for a longer period of time, you need to take the proper steps to protect your contents.

## Vacation Time

- **Short vacations:** Leave the appliance operating during vacations of less than three weeks.
- **Long vacations:** If the appliance will not be used for several months, remove all items and turn off the appliance. Clean and dry the interior thoroughly. To prevent odor and mold growth, leave the door open slightly, blocking it open if necessary.

## Transporting Your Appliance

If you need to move your appliance once the box has been discarded:

1. Securely tape down all loose items (shelves) inside your appliance.
2. Turn the adjustable legs up to the base to avoid damage.
3. Tape the door shut.
4. Be sure the appliance stays secure in the upright position during transportation. Also protect the outside of the appliance with a blanket or similar item.

## Energy Saving Tips

- The appliance should be located in the coolest area of the room, away from heat-producing appliances and out of direct sunlight.
- Ensure that the unit is adequately ventilated. Never cover air vents.
- Do not keep the door open any longer than necessary.



# TROUBLESHOOTING

You can solve many common problems easily, saving you the cost of a possible service call. Try the suggestions below to see if you can solve the problem before calling the servicer.

PROBLEM	POSSIBLE CAUSE	REMEDY
Appliance does not operate.	The unit defrosts automatically in normal operating conditions. The appliance is turned off. Tripped circuit breaker or a blown fuse.	Connect the appliance. Switch on the appliance. Switch on the circuit breaker or replace the fuse.
Appliance is not cold enough.	The temperature is not set correctly. The ambient temperature could require a lower temperature setting. The door was opened too often. The door was not closed completely. Door is not hermetically sealed. The condenser is too dirty. The ventilation opening is blocked or too dusty.	Check the set temperature. Set a lower temperature. Do not open the door more often than necessary. Close door properly. Check the door seal and clean or replace. Clean the condenser when necessary. Clear the obstructions and clean the dust.
Appliance turns itself on and off frequently.	The room temperature is higher than average. A large number of bottles has been added to the unit. The door is open too often. The door is not closed completely. The door gasket does not seal properly.	Put the appliance in a cooler place. Leave the appliance to work for a while until the set temperature has been reached. Do not open the door more often than necessary. Close door properly. Check the door seal and clean or replace.
The light does not work.	Appliance is not connected to a power supply. Tripped circuit breaker or a blown fuse. The light was switched off on the control panel.	Connect the appliance. Switch on the circuit breaker or replace the fuse. Switch on the light.
Vibrations	The appliance is not properly level.	Level the appliance with the adjustable feet.
The appliance seems to make too much noise.	The rattling noise may come from the flow of the refrigerant, which is normal. As each cycle ends, you may hear gurgling sounds caused by the flow of refrigerant in your appliance. If temperature fluctuations occur, the contraction and expansion of the inner walls may cause popping and crackling noises.	
	The appliance is not properly level.	Level the appliance with the adjustable feet.
The door will not close properly.	The appliance is not properly level. The door was reversed and not properly installed. The gasket is dirty. The shelves are out of position.	Level the appliance with the adjustable feet. Check the door hinge and reassemble correctly. Clean the door gasket. Check the shelves and refit correctly.
Display "E1" , "E2" .	"E1" or "E2" indicates that the upper zone air temperature sensor has failed.	Call for service.

If your unit shows other symptoms than those described above, or if you have checked all items listed as the cause and the problem still exists, then call SUMMIT® Customer Service at **1-800-932-4267**.

# LIMITED WARRANTY

## ONE-YEAR LIMITED WARRANTY

Within the 48 contiguous United States, for one year from the date of purchase, when this appliance is operated and maintained according to instructions attached to or furnished with the product, warrantor will pay for factory-specified parts and repair labor to correct defects in materials or workmanship. Service must be provided by a designated service company. Outside the 48 states, all parts are warranted for one year from manufacturing defects. Plastic parts, shelves and cabinets are warranted to be manufactured to commercially acceptable standards, and are not covered from damage during handling or breakage.

## 5-YEARS COMPRESSOR WARRANTY

1. The compressor is covered for 5 years.
2. Replacement does not include labor.

### **ITEMS WARRANTOR WILL NOT PAY FOR:**

1. Service calls to correct the installation of your appliance, to instruct you how to use your appliance, to replace or repair fuses or to correct wiring or plumbing.
2. Service calls to repair or replace appliance light bulbs or broken shelves. Consumable parts (such as filters) are excluded from warranty coverage.
3. Damage resulting from accident, alteration, misuse, abuse, fire, flood, acts of God, improper installation, installation not in accordance with electrical or plumbing codes, or use of products not approved by warrantor.
4. Replacement parts or repair labor costs for units operated outside the United States.
5. Repairs to parts or systems resulting from unauthorized modifications made to the appliance.
6. The removal and reinstallation of your appliance if it is installed in an inaccessible location or is not installed in accordance with published installation instructions.

## DISCLAIMER OF IMPLIED WARRANTIES – LIMITATION OF REMEDIES

CUSTOMER'S SOLE AND EXCLUSIVE REMEDY UNDER THIS LIMITED WARRANTY SHALL BE PRODUCT REPAIR AS PROVIDED HEREIN. IMPLIED WARRANTIES, INCLUDING WARRANTIES OF MERCHANTABILITY OR FITNESS FOR A PARTICULAR PURPOSE, ARE LIMITED TO ONE YEAR. WARRANTOR SHALL NOT BE LIABLE FOR INCIDENTAL OR CONSEQUENTIAL DAMAGES. SOME STATES DO NOT ALLOW THE EXCLUSION OR LIMITATION OF INCIDENTAL OR CONSEQUENTIAL DAMAGES, OR LIMITATIONS ON THE DURATION OF IMPLIED WARRANTIES OF MERCHANTABILITY OR FITNESS, SO THESE EXCLUSIONS OR LIMITATIONS MAY NOT APPLY TO YOU. THIS WARRANTY GIVES YOU SPECIFIC LEGAL RIGHTS AND YOU MAY ALSO HAVE OTHER RIGHTS, WHICH VARY FROM STATE TO STATE.



**WARNING: This product can expose you to chemicals including Nickel (Metallic) which is known to the State of California to cause cancer.**

For more information go to [www.P65Warnings.ca.gov](http://www.P65Warnings.ca.gov)

Note: Nickel is a component in all stainless steel and some other metallic compositions.

**Felix Storch, Inc.**  
An ISO 9001:2015 registered company  
770 Garrison Avenue  
Bronx, NY 10474  
[www.summitappliance.com](http://www.summitappliance.com)

**SUMMIT**<sup>®</sup>  
For parts and accessory ordering,  
troubleshooting and helpful hints, visit:  
[www.summitappliance.com/support](http://www.summitappliance.com/support)

Revised 08/2021