

1. External Parts

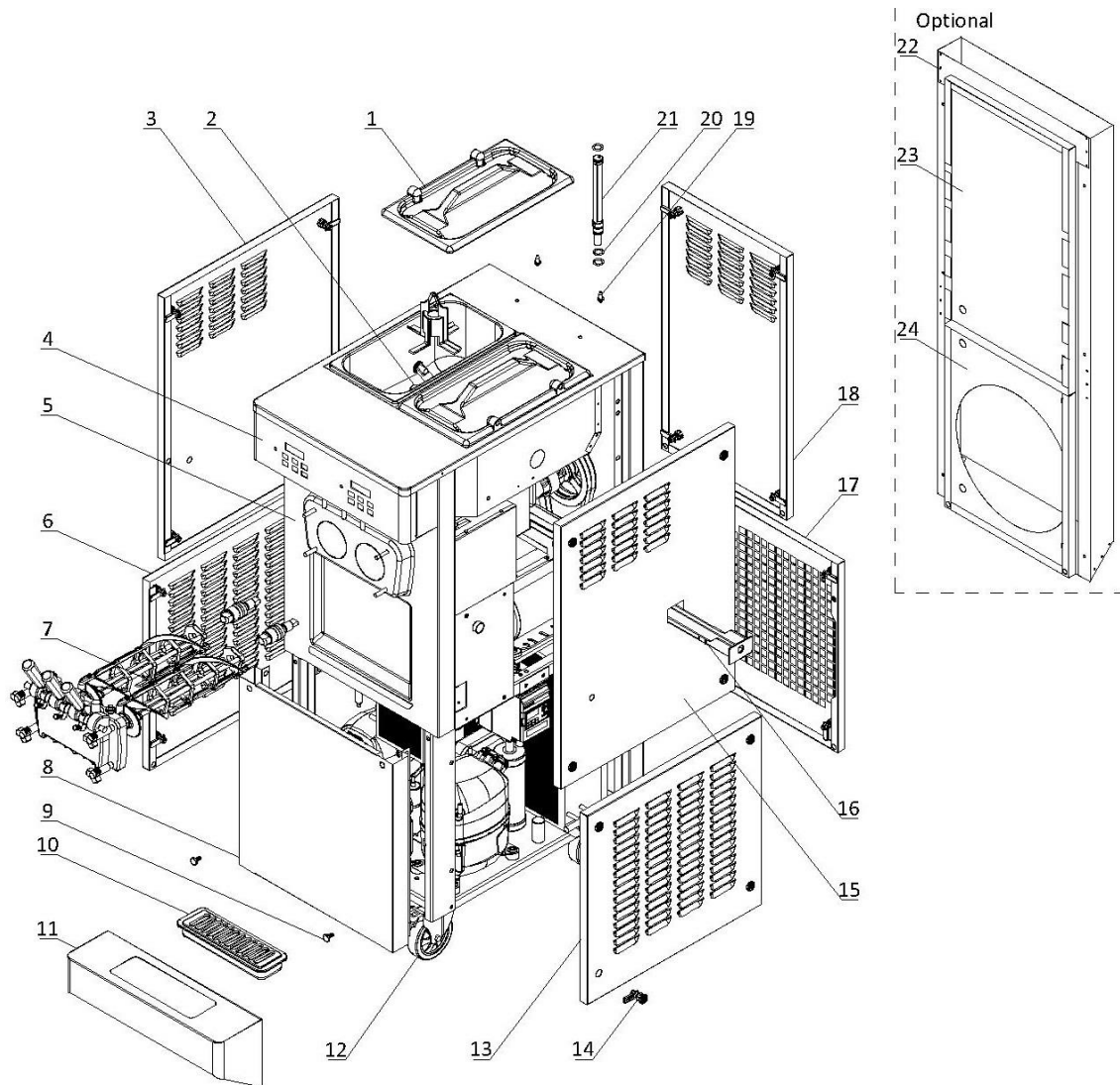

1. External Parts

Item	Part Number	Description	Qty.
1	3.4.03.01.004	Hopper Lid - 12-15L	2
2	Page 7	Hopper Agitator	1
3	2.3.4.29.027	Panel - Upper Left - 2F - 3.4qt	1
4	Page 6	Draw Switch and Front control Panel	1
5	2.3.4.26.059	Panel - Middle Front - 2F - 3.4qt	1
6	2.3.4.32.037	Panel - Lower Left - 2F - 3.4qt	1
7	Page 5	Dispensing Door and Beater	1
8	2.3.4.27.040	Panel - Lower Front - 2F - 3.4qt	1
9	3.6.39.004	Drip Tray Mounting Bolt	2
10	3.4.04.01.006	Front Drip Tray - 30mm	1
11	2.3.4.45.052	Support - Front Drip Tray - 6378-C	1
12	3.3.05.02.002	Caster Swivel - 125X34	4
13	2.3.4.32.038	Panel - Lower Right - 2F - 3.4qt	1
14	8.1.07.001	Panel Lock Assembly	24
15	2.3.4.31.028	Panel - Upper Right - 2F - 3.4qt	1
16	3.4.04.02.001	Internal Drip Tray - 45mm	1
17	2.3.4.25.043	Panel - Lower Rear - 2F - 3.4qt	1
18	2.3.4.24.035	Panel - Upper Rear - 2F - 3.4qt	1
19	3.6.39.011	Hopper Lid Holder	2
20	3.4.08.01.002	O-Ring - 18x2.2	3
21	2.1.3.39.0011	Air Tube - SS - Long - V3	2
22	2.3.4.34.064	Air Chute - 2F - 3.4qt (Optional)	1
23	2.3.4.24.036	Panel - Air Chute - 2F - 3.4qt - Upper Rear (Optional)	1
24	2.3.4.25.044	Panel - Air Chute - 2F - 3.4qt - Lower Rear (Optional)	1

2. Internal Parts

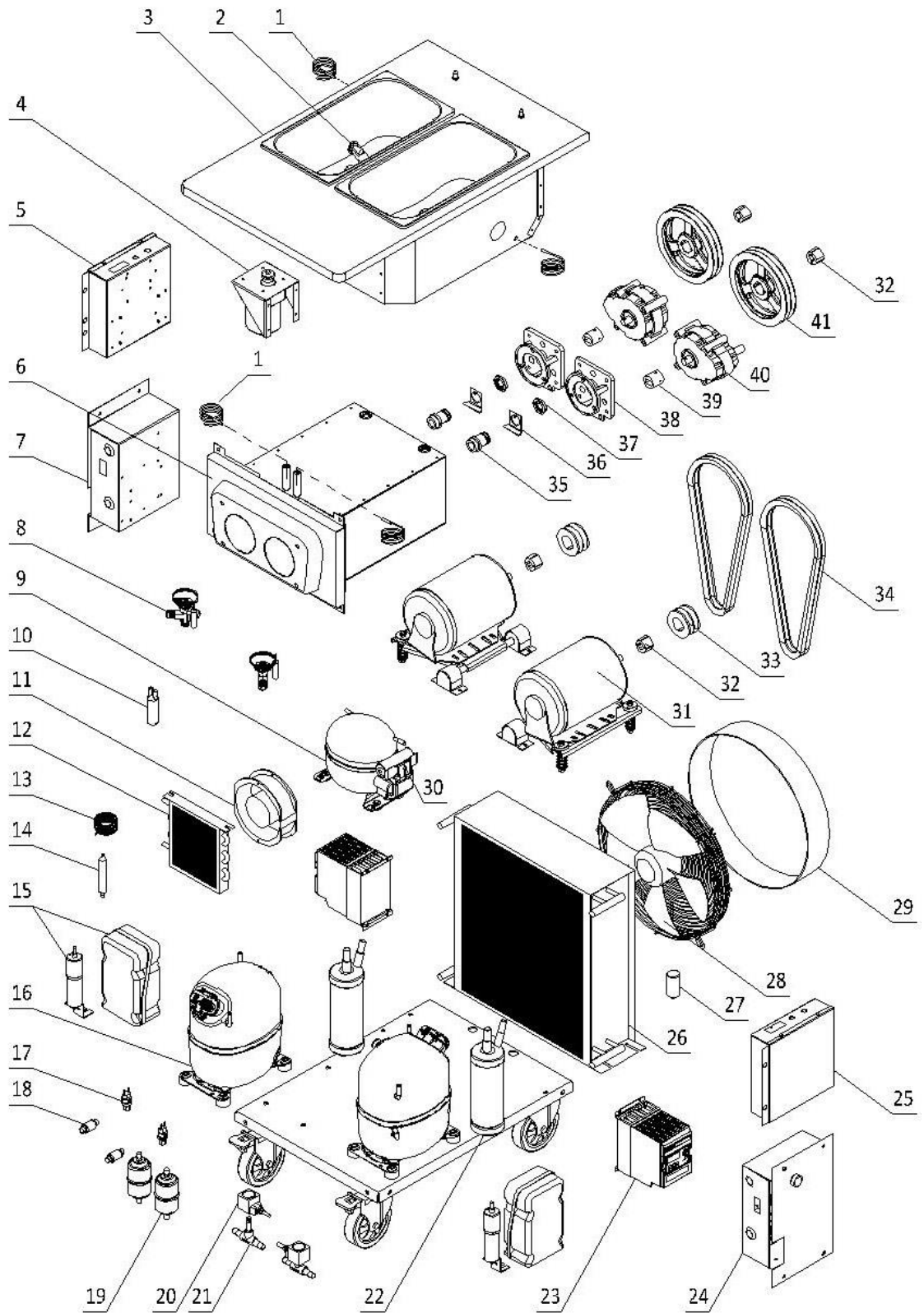

Item	Part Number	Description	Qty.
1	3.1.02.13.020	Temperature Probe - PT100	4
2	920.1.04.0002	Mix Low Sensor Assembly	2
3	2.1.1.03.0058	Hopper Assembly - 6378-C	1
4	Page 7	Agitator Motor	1
5	Page 9	Control Box - Left	1
6	2.1.1.06.0045	Cylinder Assembly - 2F - 3.4qt	1
	2.1.1.06.0162	W.E. Cylinder Assembly - 2F - 3.4qt	1
7	Page 8	Electrical Box - Left	1
8	3.2.04.01.013	Thermal Expansion Valve - TUB2134	2
	3.2.04.01.001	Expansion Valve - T2 (Adapters included) (Alternative)	2
9	3.2.01.01.005.A	Auxiliary Compressor - TL3G	1
10	3.2.04.07.001	Suction Accumulator - 25×100×0.6	1
11	3.2.03.01.001	Fan Motor - BT220-15050S2HL	1
	3.2.03.01.005	Fan Motor - UF-1751B22H (Alternative)	1
12	3.2.02.01.001	Auxiliary Condenser - Single - 0.7m ²	1
13	3.2.05.01.003	Capillary Tube - 2.2×0.9	1
14	3.2.04.05.001	Filter Drier - Hopper - 16×2.2×120	1
15	3.2.01.04.004	Start Component - Compressor - CAJ2464Z	2
	3.2.01.04.024	Start Component - Compressor - CAJ4519Z (Alternative)	2
16	3.2.01.02.005.A	Primary Compressor - CAJ2464Z	2
	3.2.01.02.042.A	Primary Compressor - CAJ4519Z (Alternative)	2
17	3.2.04.06.004	High Pressure Switch - 350~500psi	2
18	3.2.04.05.010	Copper Strainer Filter - φ12	2
19	3.2.04.05.002	Filter Drier - Cylinder - DML083S	2
20	3.2.04.04.020	Solenoid Coil - 220V/6W	2
21	3.2.04.04.004	Solenoid Valve Body - EVU6 - 6W	2
22	3.2.04.08.001	liquid Receiver - 76x280	2
23	3.1.01.08.006	Inverter - 0.75kW - EFC3610-0K75-1P2-MDA	2
24	Page 8	Electrical Box - Right	1
25	Page 9	Control Box - Right	1
26	3.2.02.01.010	Main Condenser - Dual - 15m ²	1
27	3.2.03.04.001-2	Capacitor - Fan Motor - 450V - 5μF - CBB60	1
28	3.2.03.04.001	Fan Motor - 220/60/1 - YWF4E-350S	1
29	2.1.3.50.0002	Fan Shroud - 120mm	1
30	3.2.01.01.005-1	Start Component - Compressor - TL3G	1
31	3.3.01.04.005	Motor - 220/60/3 - 750W - P56AH60F41	2
32	3.3.04.01.005	Bushing - 1008-16	4
33	3.3.04.02.001	Pulley - Beater Motor - SPA63-2-1008	2
34	3.3.03.01.003	Belt - Motor - Beater - V-XPA1030	4
35	3.3.02.02.002	Rear Shell Bearing - SS (3.4qt) + FB	2
36	2.3.6.04.004	Lock Plate - Rear Shell Bearing - 42mm	2
37	3.3.02.02.010	Nut - Rear Shell Bearing	2
38	2.1.3.15.0004	Bracket - Gear Box - 3.4-7.3qt - 89mm	2
39	3.3.02.04.009	Coupling Drive - 3.4qt-4.0qt-7.3qt - 20mm - V2	2
40	3.3.02.01.023	Gear Box - SS - 45*20 Shaft - 89mm	2
	3.3.02.01.028	Gear Box - SS - 45*20 Shaft - 89mm (Alternative)	2
41	3.3.04.02.007	Pulley - Gear Box - SPA182-2-1008	2

2. Dispensing Door and Beater

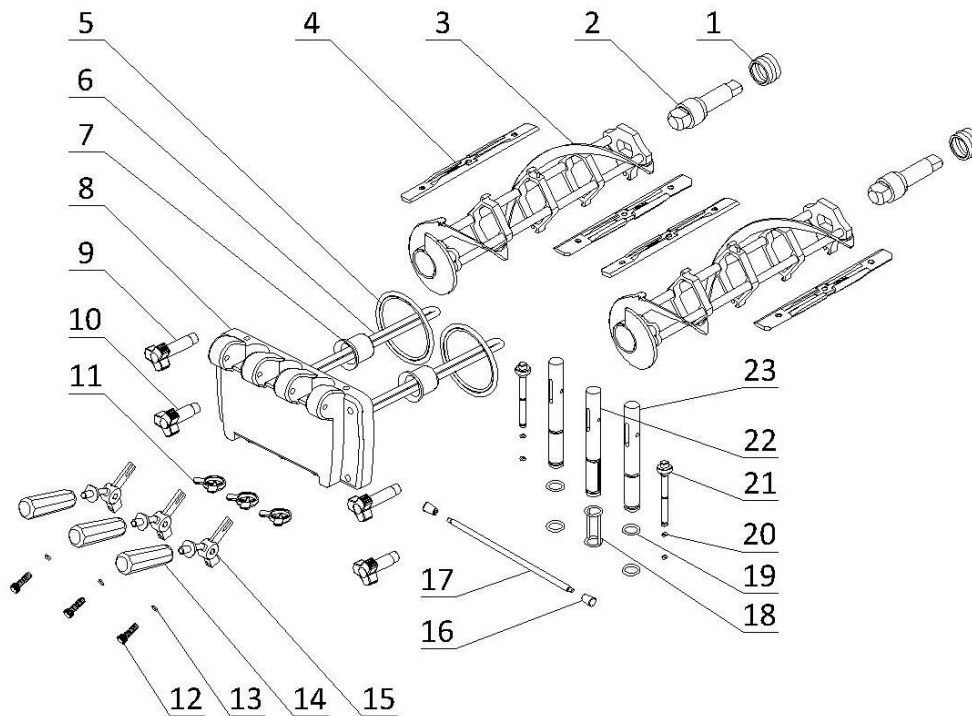

Item	Part Number	Description	Qty.
1	3.4.07.05.002	Gasket - Drive Shaft	2
2	2.1.3.25.0002	Drive Shaft - SS - 3.4qt	2
3	2.1.1.10.0018	Beater - SS - Large - 3.4qt - V2	2
4	3.4.02.01.007	Scraper Blade - Medium - V2	4
	3.4.02.01.009	Scraper Blade - 243mm (Alternative)	4
5	3.4.08.02.008	Door Gasket - SS - 3.4qt	2
6	2.1.1.11.0019	Beater Rod - SS - Large - 3.4qt (With O-Ring)	2
7	3.4.01.03.008	Beater Guide - SS - 3.4qt - V2	2
8	2.1.3.14.0005	Dispensing Door - SS - 2F - 3.4qt	1
9	3.4.05.02.011	Hand Screw - Long - Dispensing - 3.4qt	2
10	3.4.05.02.009	Hand Screw - Short - Dispensing - 3.4qt	2
11	3.4.05.03.004	Design Cap - Double Triangle - 31mm	3
12	3.6.39.008	Adjustment Screw - Handle - 34mm	3
13	3.4.08.01.012	O-Ring - 3x1.5	3
14	3.4.05.01.001	Handle - Dispensing - SS	3
15	2.1.3.26.0002	Seat - Handle - 2F - 3.4qt	3
16	2.1.3.27.0025	Nut - Retention Pin - Handle	2
17	2.1.3.27.0003	Retention Pin - Handle - 2F - 3.4qt	1
18	3.4.08.01.015	H-Ring - 16.8x2.4x2	1
19	3.4.08.01.006	O-Ring - 16.8x2.4	4
20	3.4.08.01.013	O-Ring - 5.2x1.9	4
21	2.1.3.02.0015	Prime Plug - SS - Standard	2
22	2.1.3.02.0002	Draw Valve - SS - 2F - 3.4qt - Middle	1
23	2.1.3.01.0005	Draw Valve - SS - 2F - 3.4qt - Side	2

3. Draw Switch and Front Control Panel

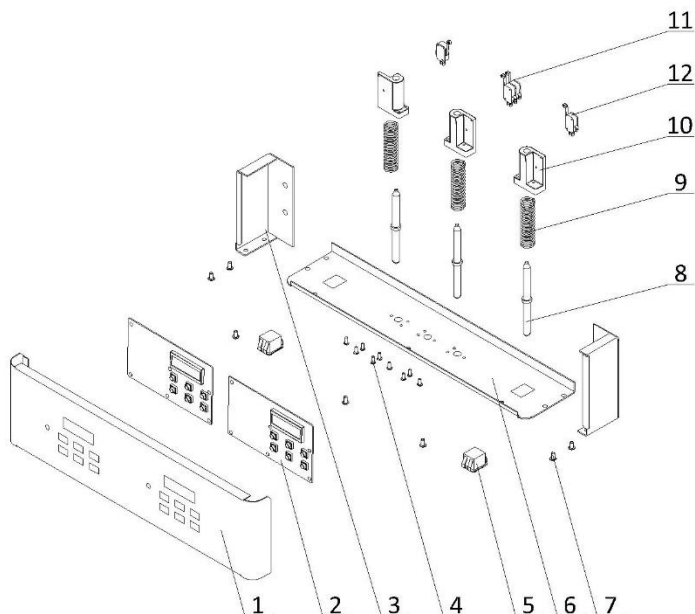

Item	Part Number	Description	Qty.
1	2.3.4.36.048	Panel - Overhead Front - 2F - 3.4qt	1
	3.1.06.03.017	Sticker - 2F - 3.4qt	1
2	920.1.01.0006	Control Board - SS - V2.152 - Horizontal - V2	2
3	2.3.4.37.054	Panel - Overhead Side - 2F -3.4qt	2
4	3.6.22.028	Screw - M4x12	9
5	3.1.03.03.003	Power Switch - KCD2-2	2
6	2.3.4.39.076	Panel - Overhead Bottom - 2F - 3.4qt	1
7	3.6.22.010	Screw - M5x10	7
8	2.1.3.50.0068	Shaft - Draw Switch - 2F - 3.4qt	3
9	3.6.03.012	Spring - Shaft - Draw Switch	3
10	3.4.07.06.008	Bracket - Micro Switch & Shaft & Spring	3
11	3.1.03.01.002	Micro Switch - KW-7-2	2
12	3.1.03.01.005	Micro Switch - KW-7-2X2	1

4. Hopper Agitator

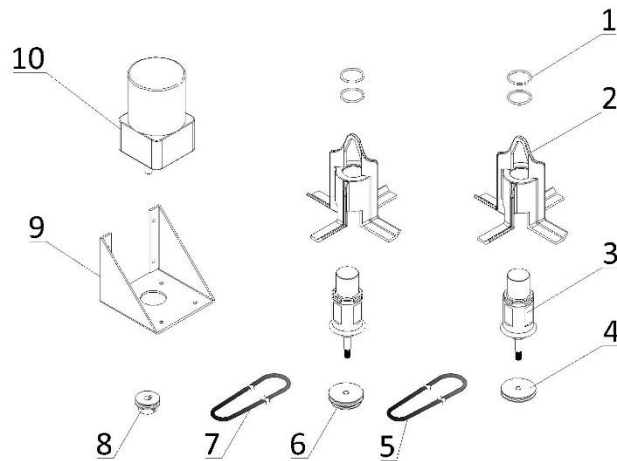

Item	Part Number	Description	Qty.
1	3.4.08.01.034	O-Ring - 31x2	4
2	2.1.1.23.0002	Blade - Hopper Agitator - Standard - V2	2
3	2.1.1.12.0002	Agitator Assembly - 137mm	2
4	2.1.4.02.015	Pulley - Hopper Agitator - Single - 53mm	1
5	920.2.09.0002	Belt - Hopper Agitator - 590mm	1
6	2.1.4.02.016	Pulley - Hopper Agitator - Double - 53mm	1
7	2.1.4.08.047	Belt - Hopper Agitator - 280mm	1
8	3.3.04.04.006	Pulley - Hopper Agitator - Drive - 30mm	1
9	2.3.4.45.007	Bracket - Agitator Motor - 110mm	1
10	3.3.01.01.006	Motor - Agitator - 220V - YN80-25-6G	1

5. Electrical Box

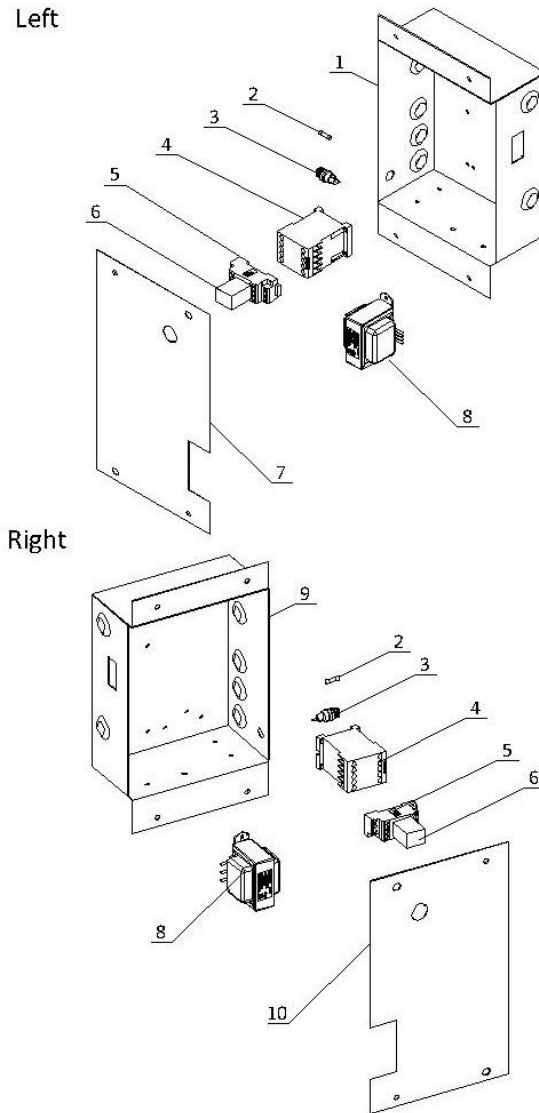

Item	Part Number	Description	Qty.
1	2.2.4.18.0002	Electrical Box - Left - 2F - 3.4qt	1
2	3.1.02.08.002	Fuse - 0.5A	2
3	3.1.02.08.012	Seat - Fuse - 250V	2
4	3.1.01.01.010	Contactor - 220V - 3RT6017-1AN21	2
5	3.1.01.03.031	Base - Relay - TP514X1-E	2
6	3.1.01.03.029	Intermediate Relay - AC220V - HH54P-L	2
7	2.2.4.21.0002	Cover - Electrical Box - Left - 2F - 3.4qt	1
8	3.1.01.04.007	Transformer - 50W - 50313MW-32	2
9	2.2.4.19.0002	Electrical Box - Right - 2F - 3.4qt	1
10	2.2.4.22.0002	Cover - Electrical Box - Right - 2F - 3.4qt	1

6. Control Box

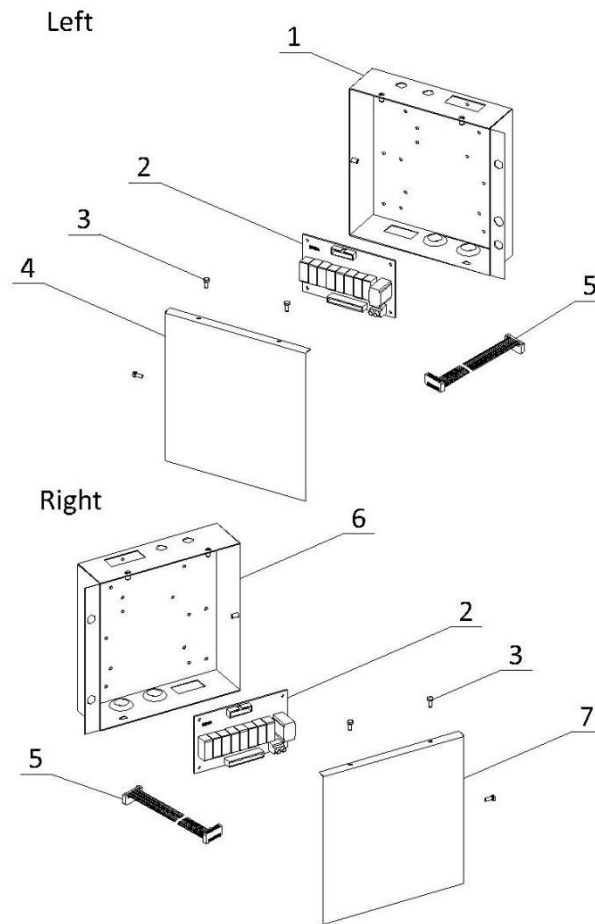

Item	Part Number	Description	Qty.
1	2.2.4.23.0005	Control Box - Left - 3.4qt	1
2	2.2.1.01.0007	Power Board - SS - V2.152	2
3	3.6.06.072	Screw - M4×10	6
4	2.2.4.23.0006	Cover - Control Box - Left - 3.4qt	1
5	3.1.04.01.003	Ribbon Cable - 20 Pin	2
6	2.2.4.23.0017	Control Box - Right - 3.4qt	1
7	2.2.4.23.0016	Cover - Control Box - Right - 3.4qt	1