

4

3

2

1

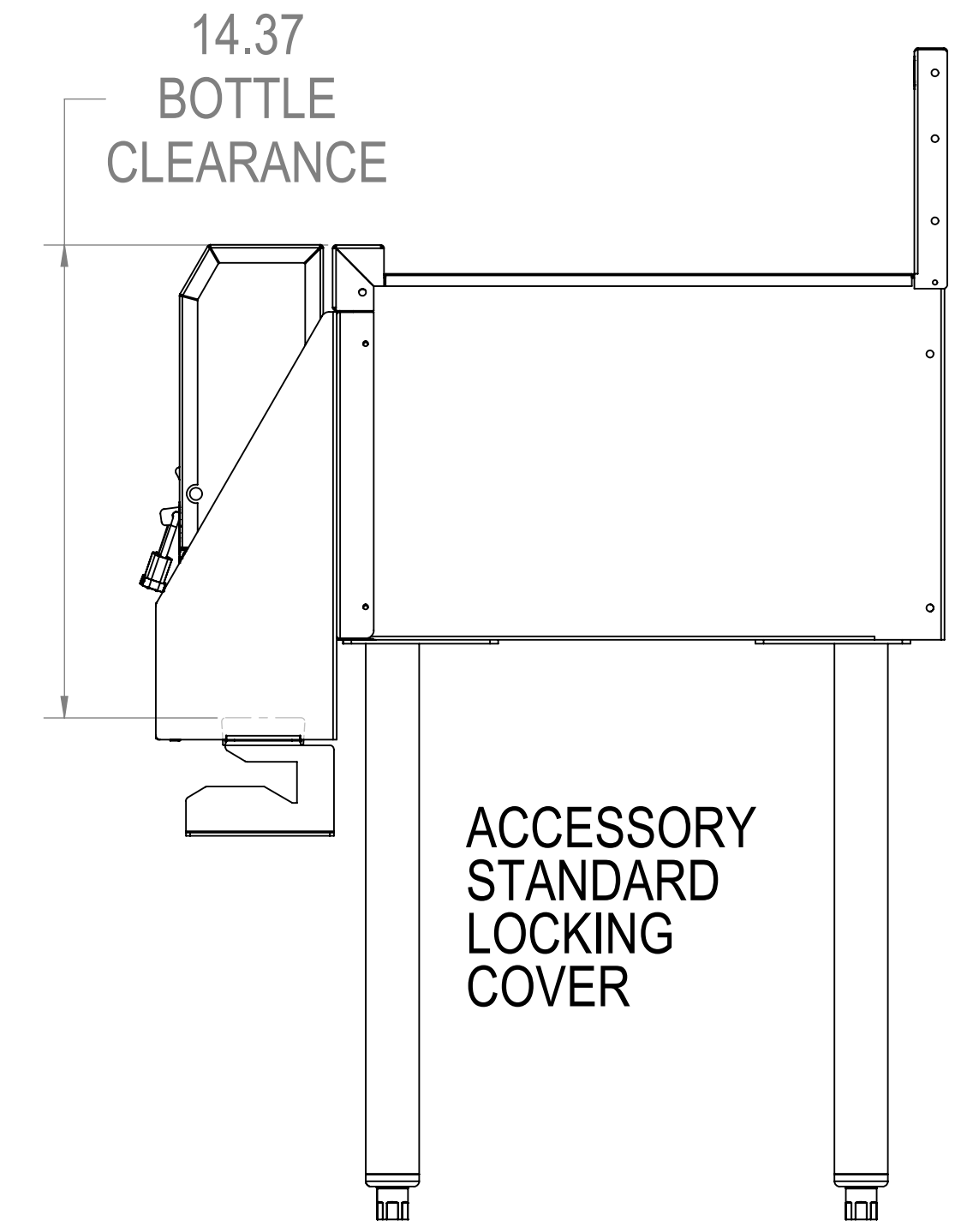
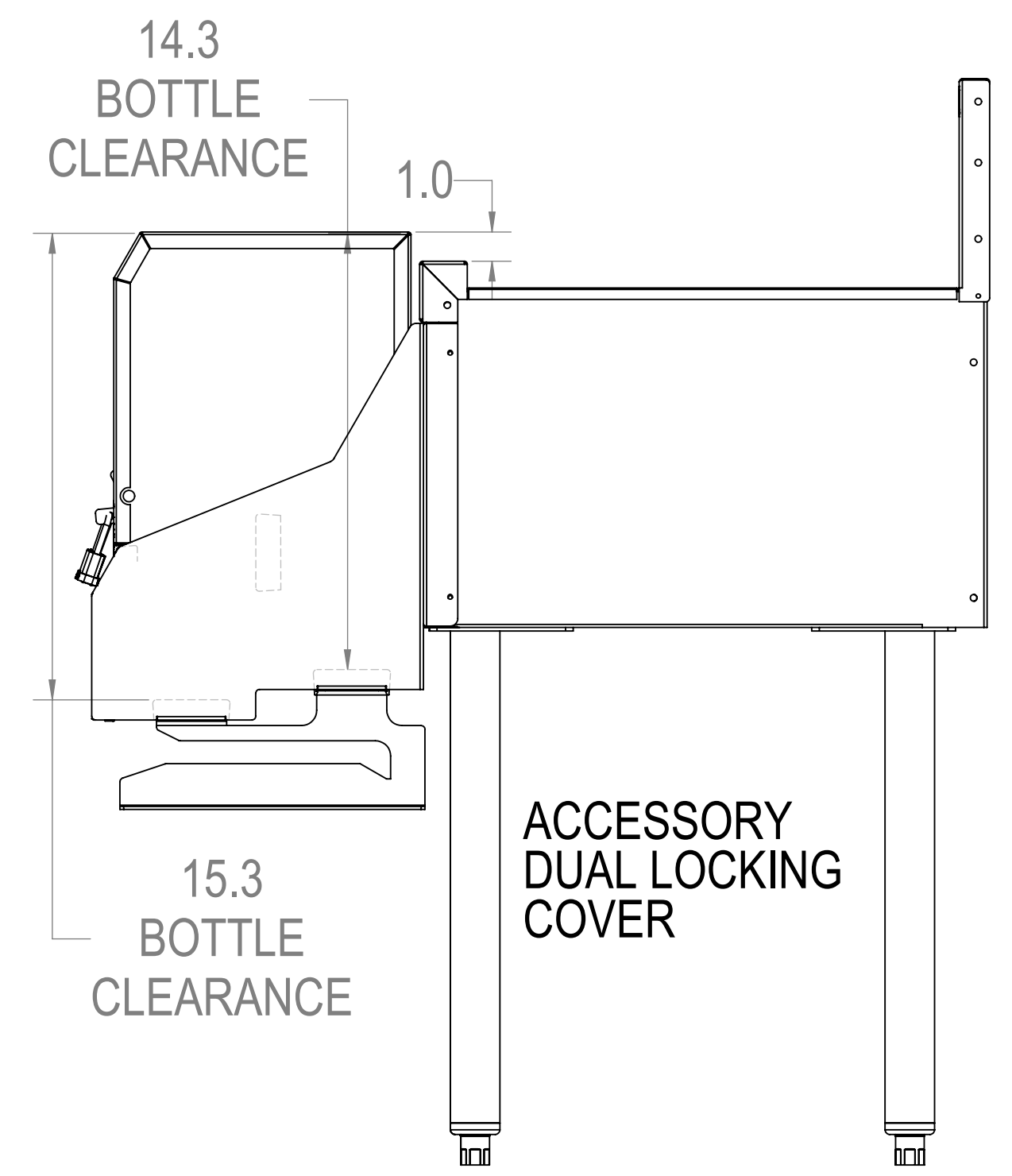
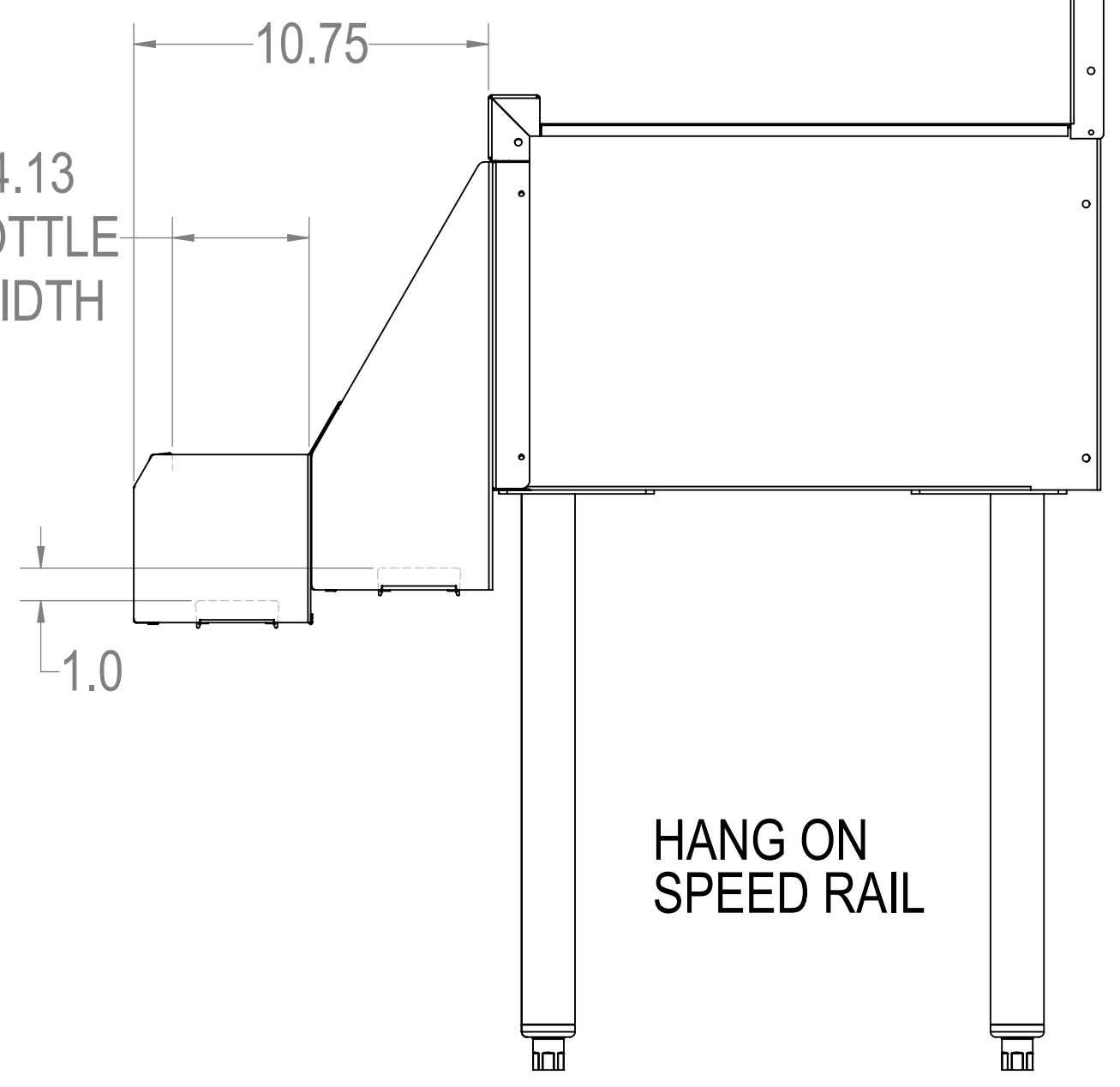
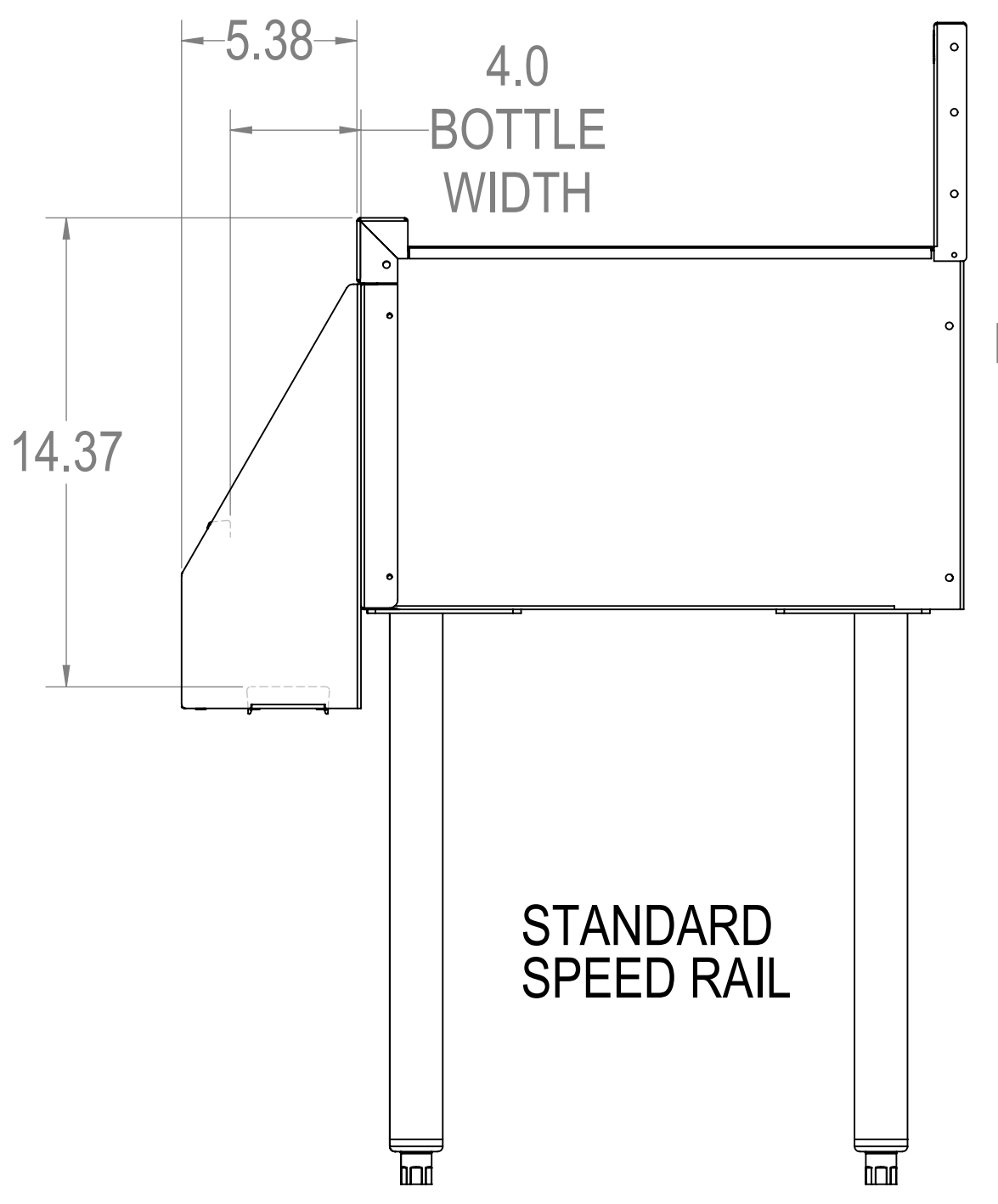
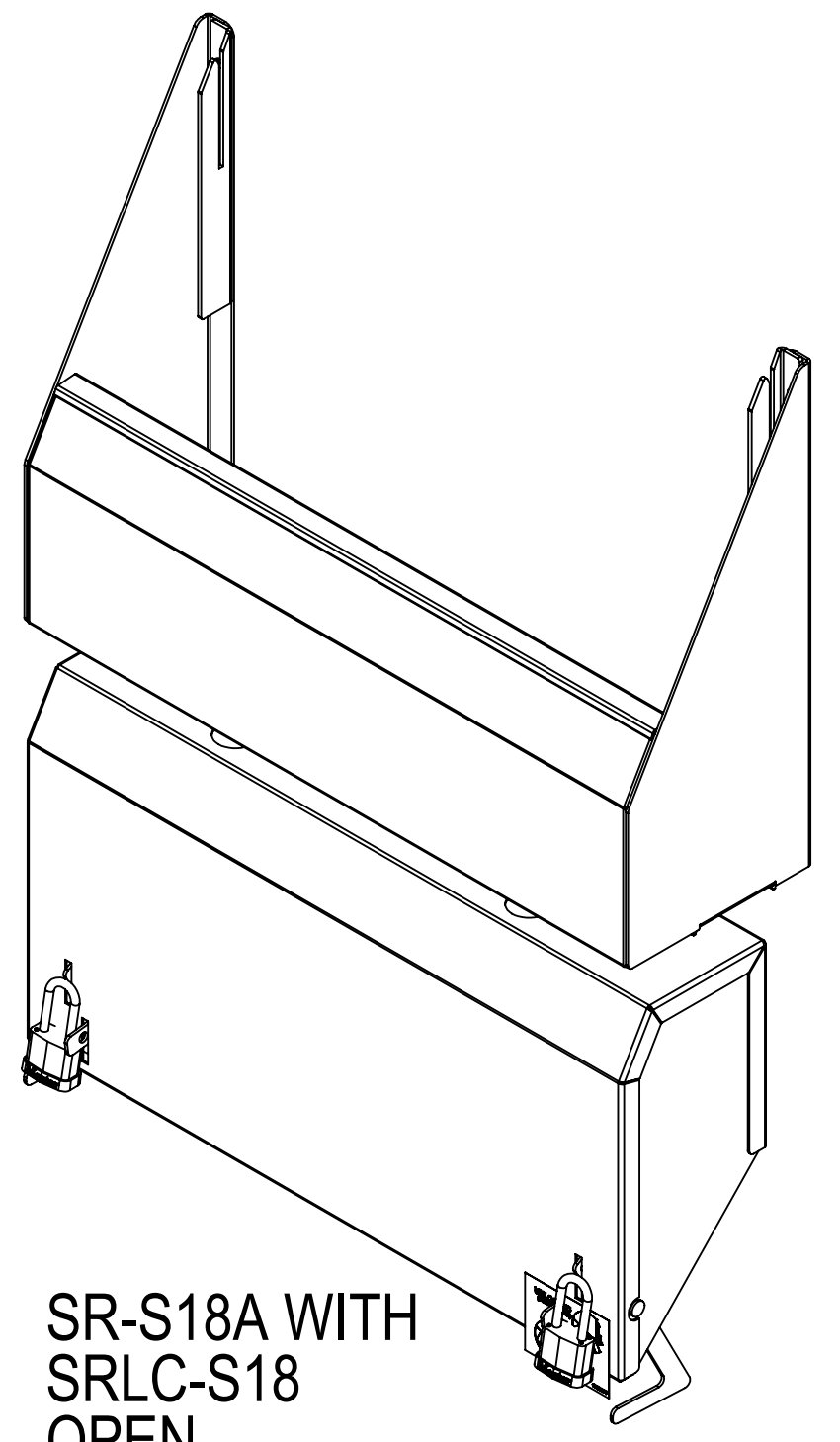

D

D

C

C

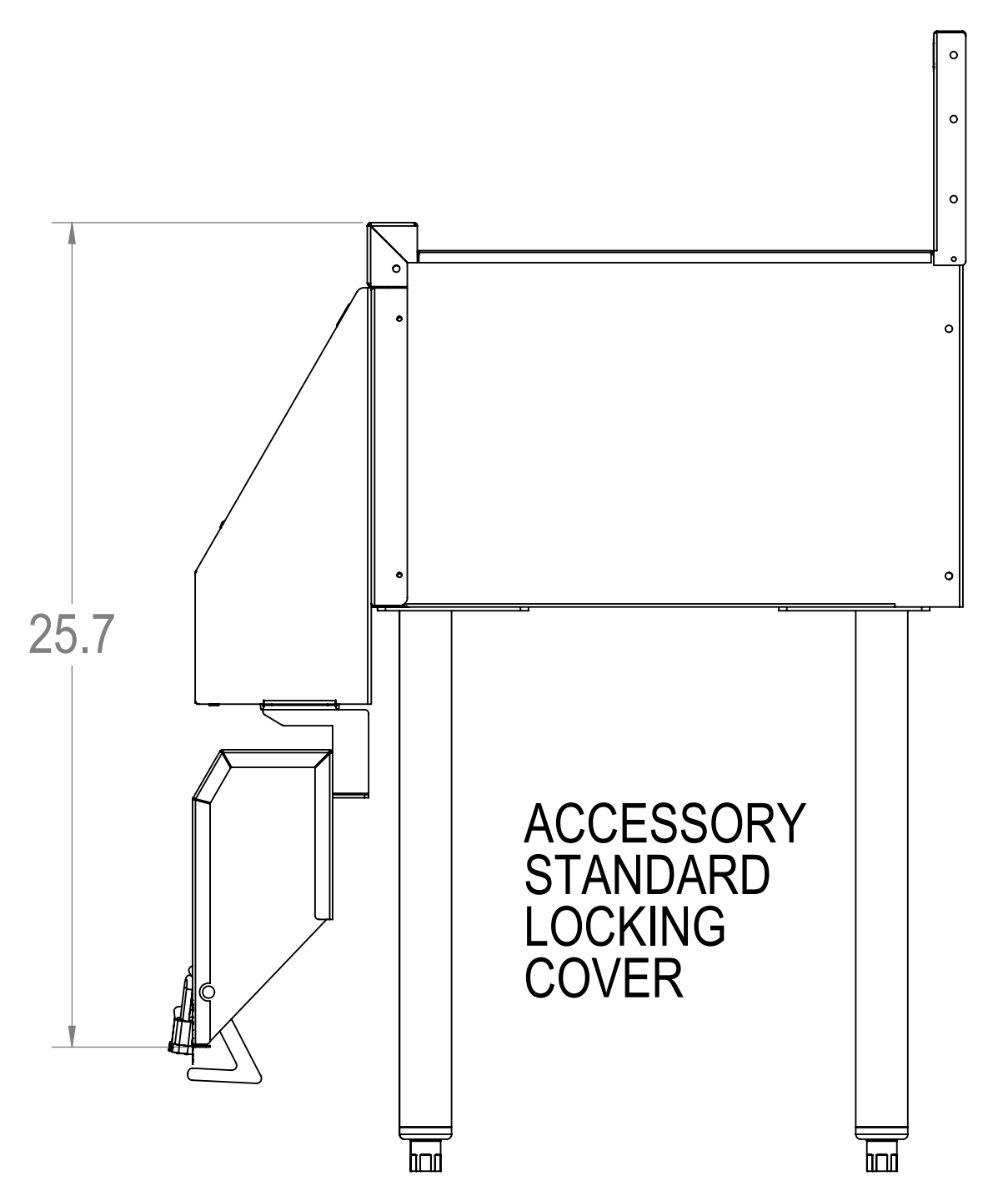
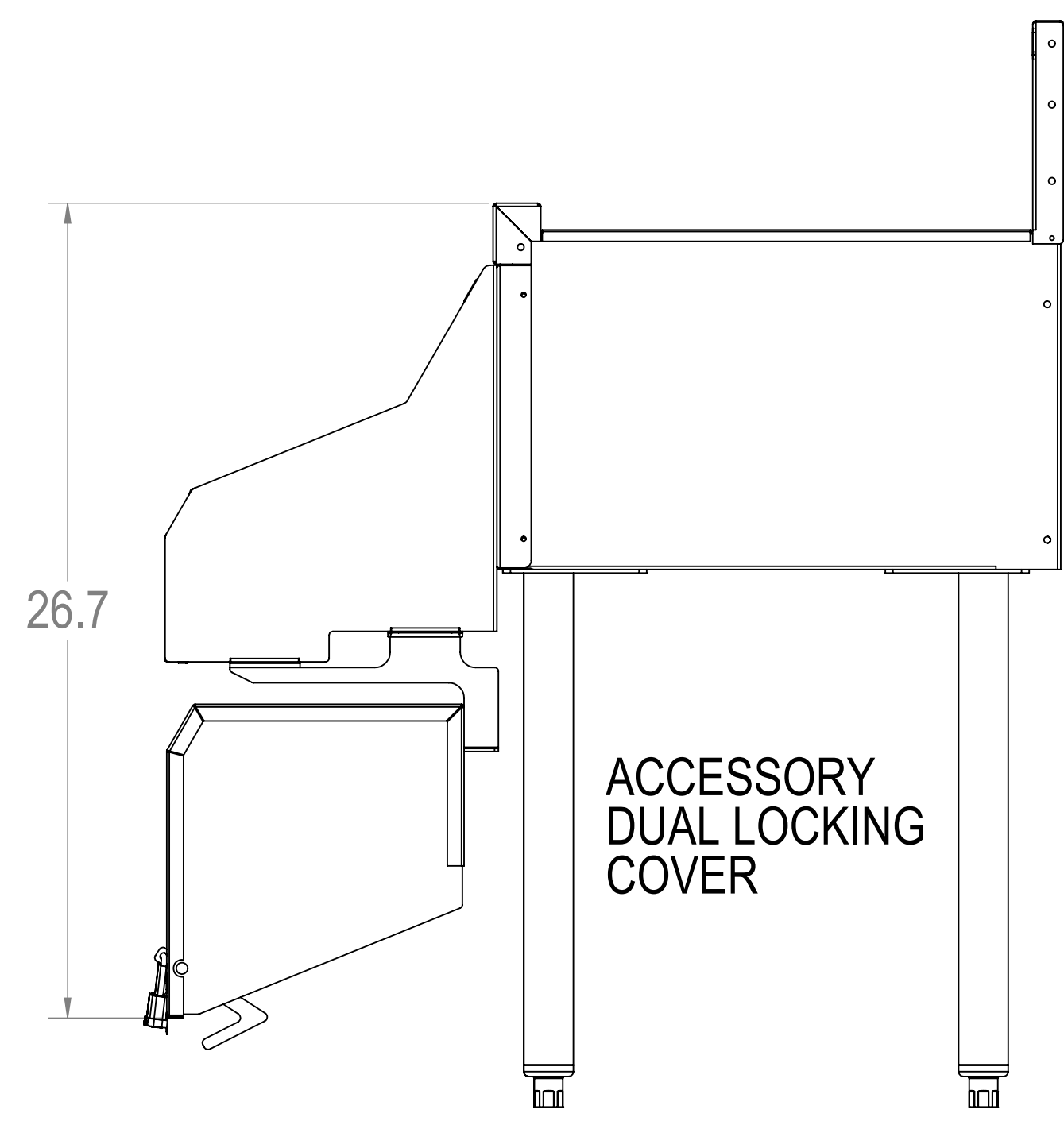
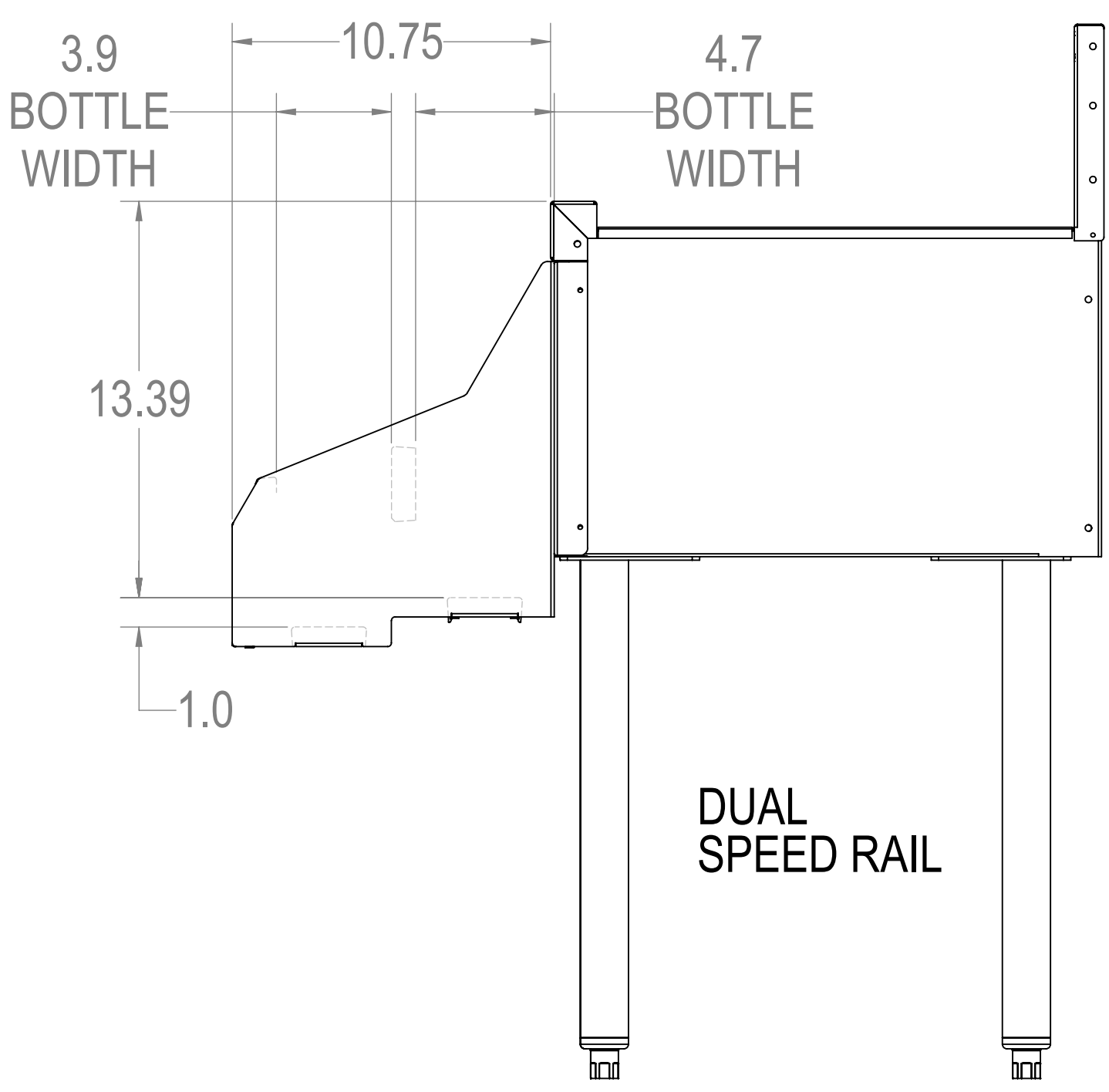
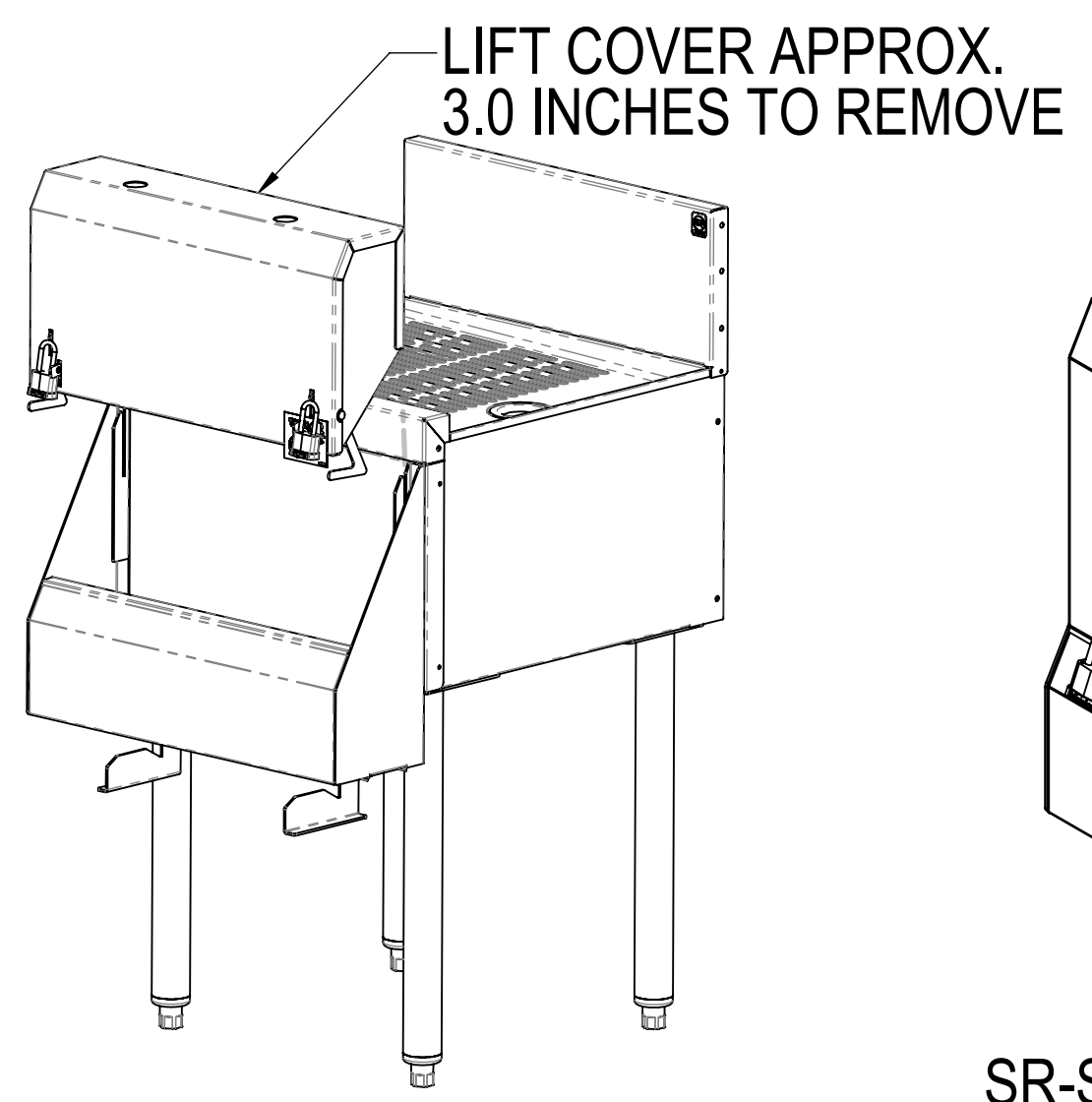

B

B

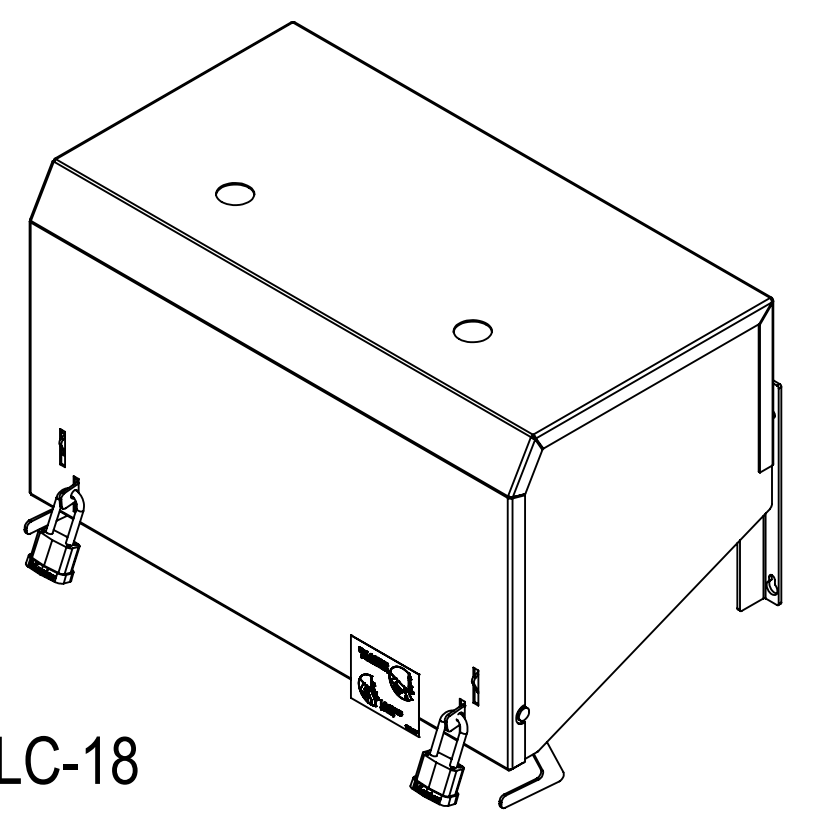
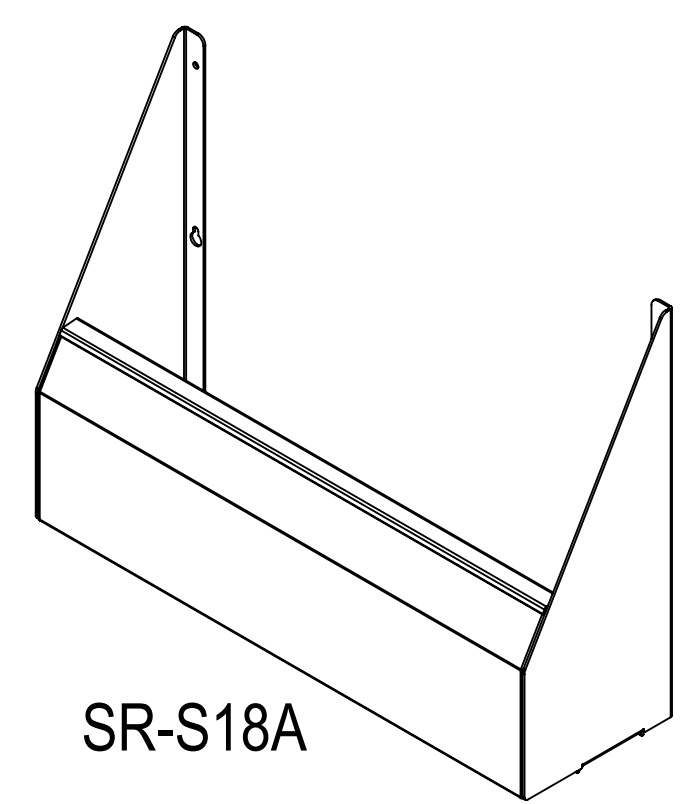
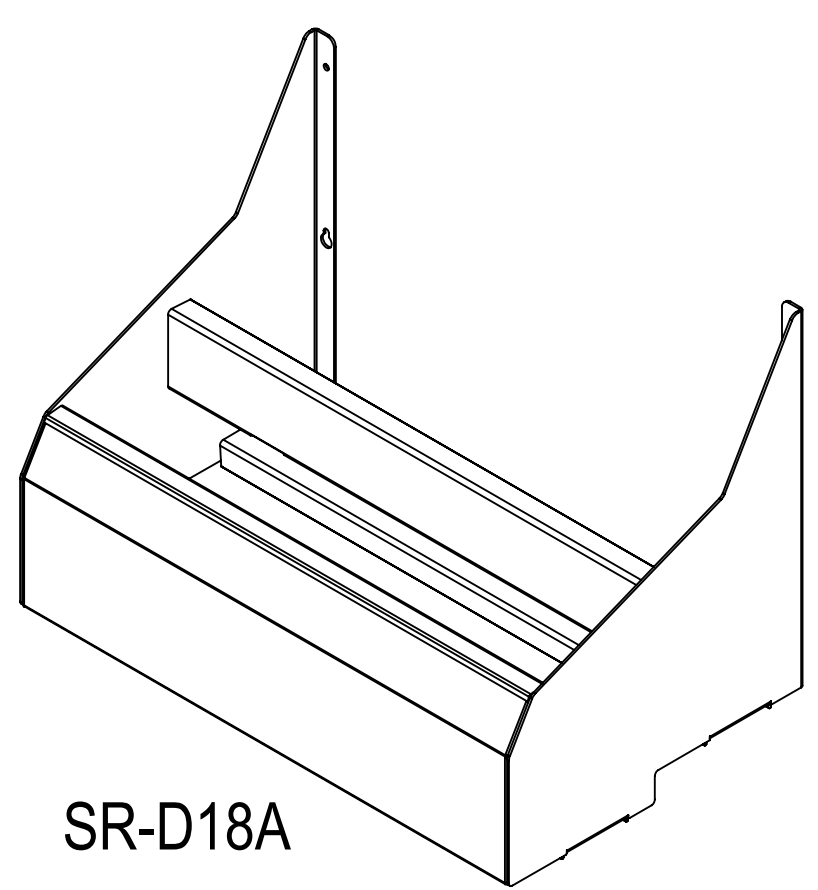
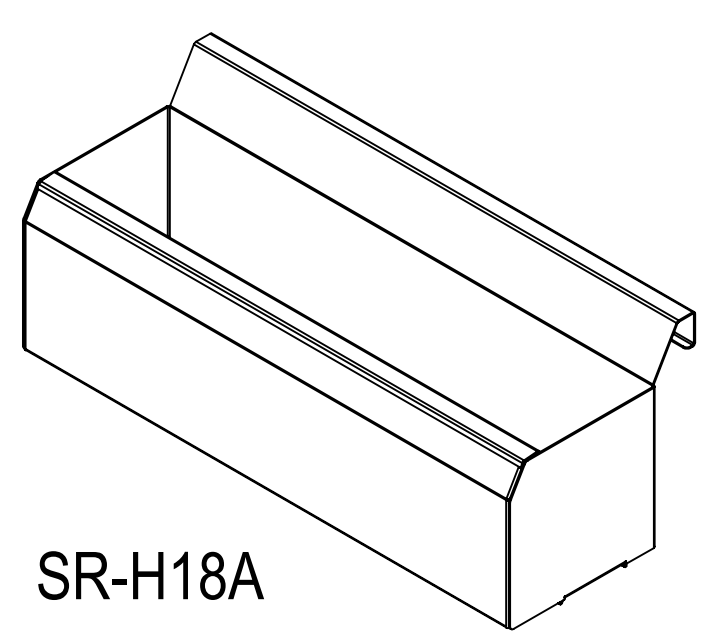
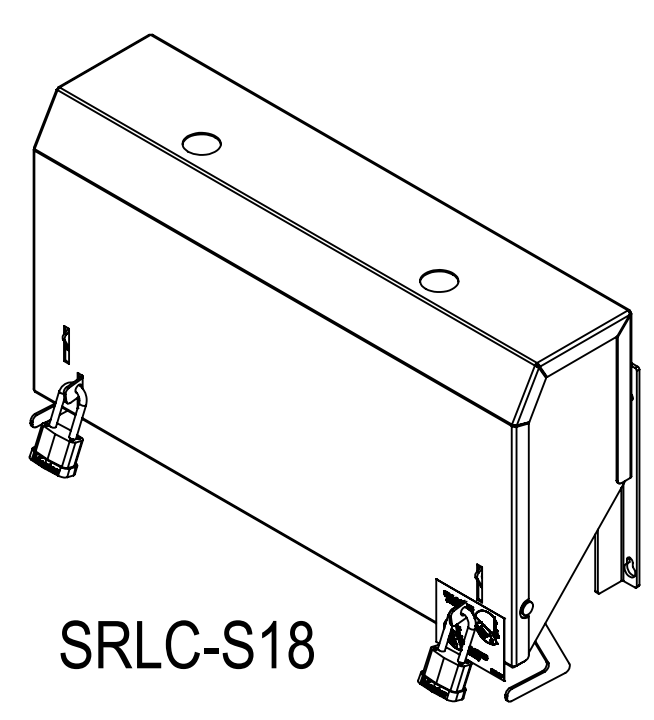
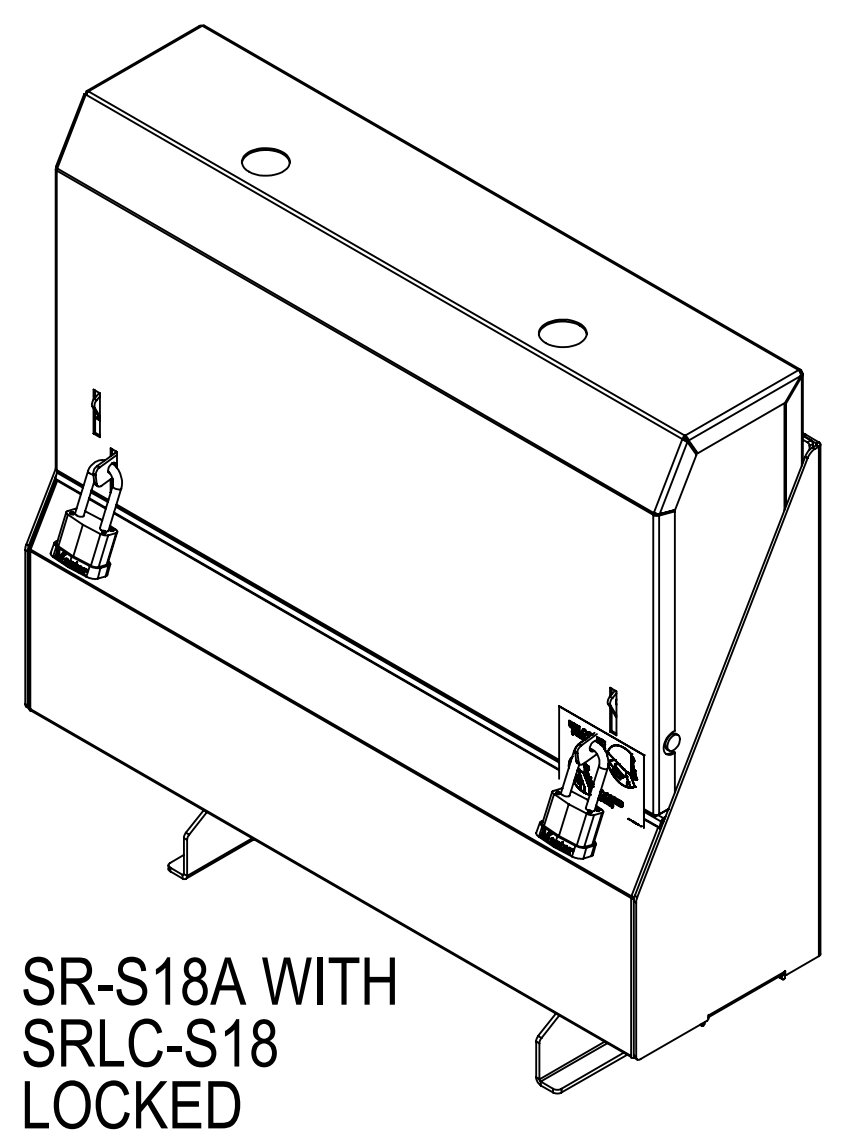

A

A

3

2

1

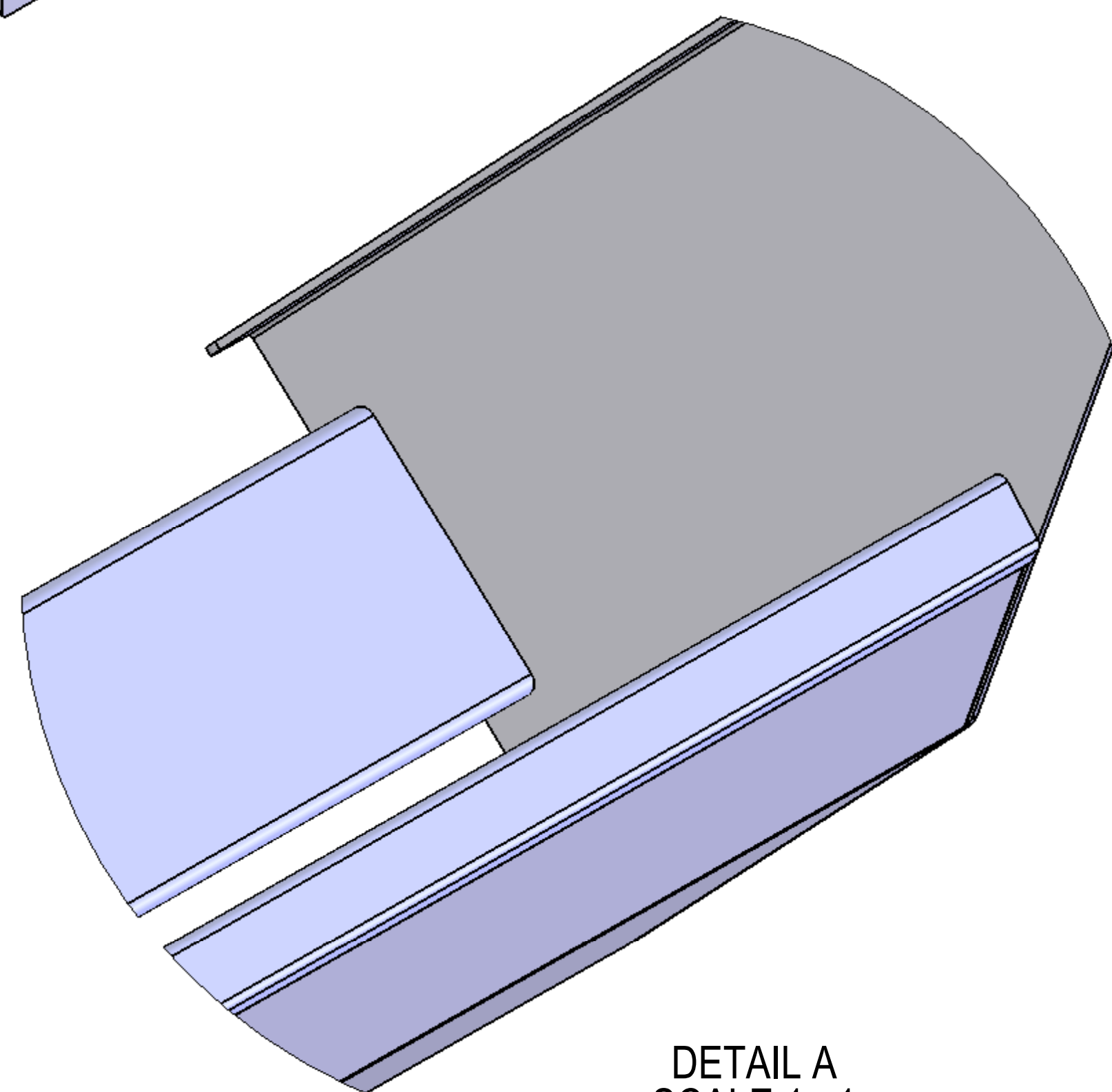
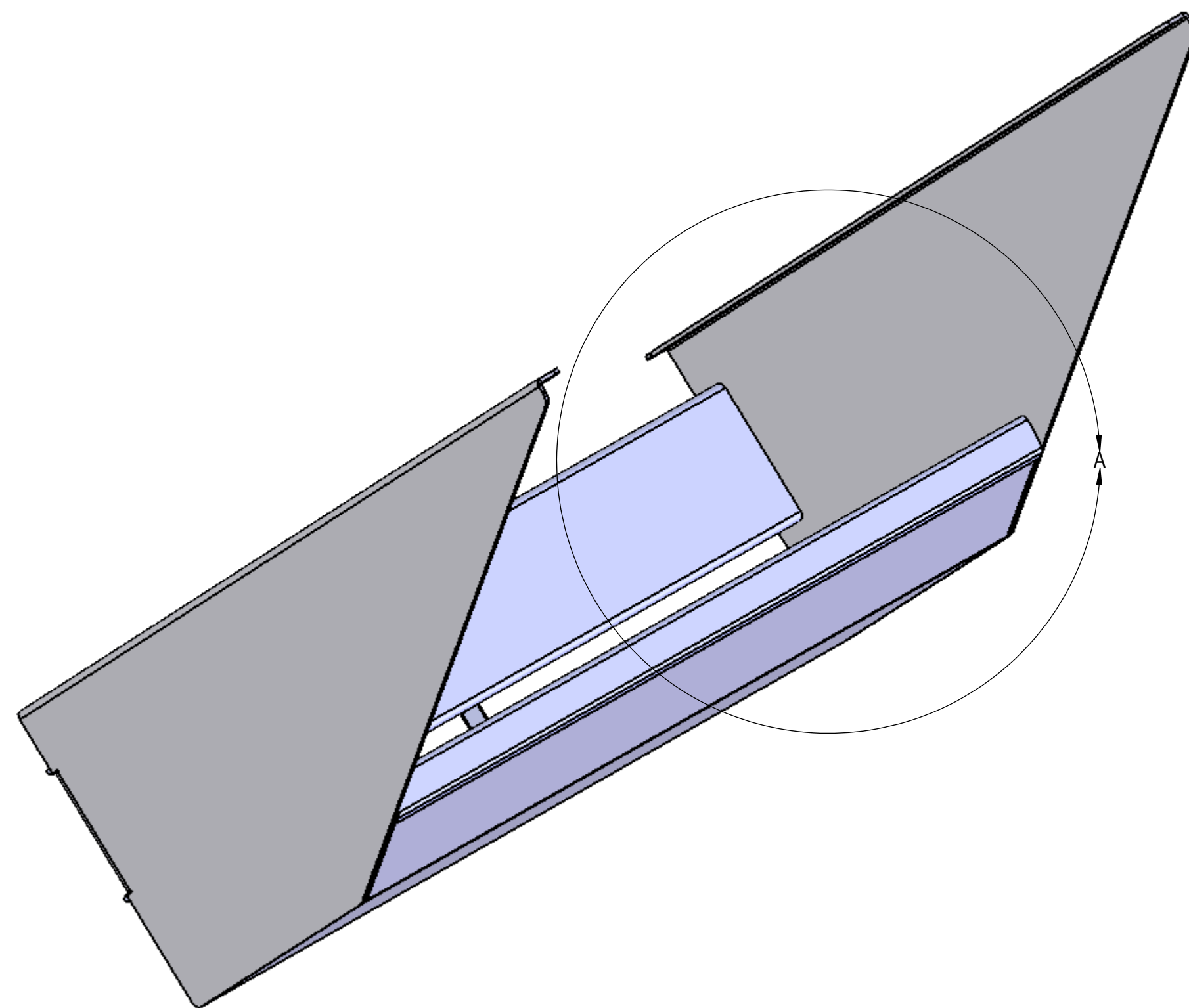
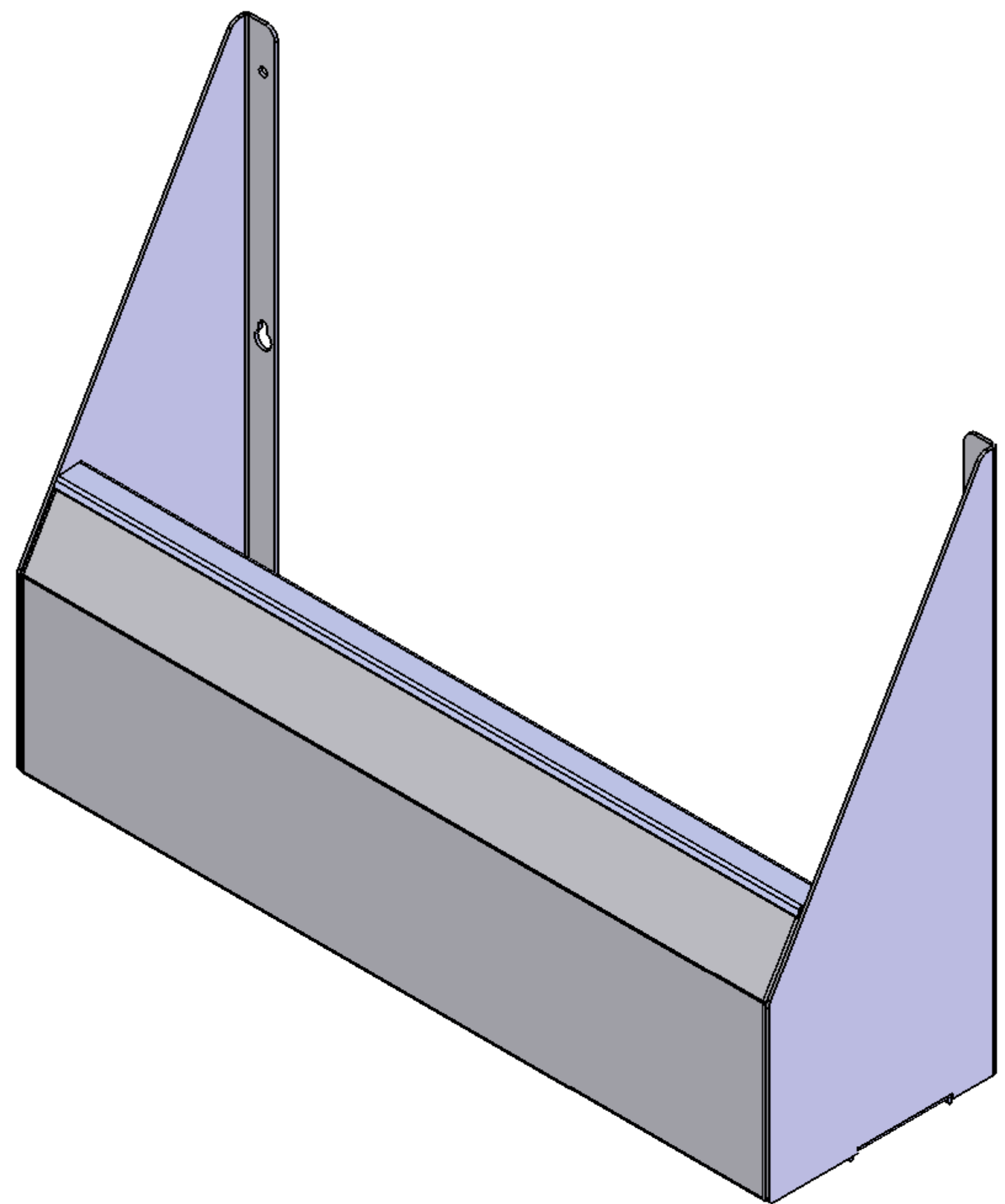

DETAIL A
SCALE 1 : 1

MATERIAL: SEE BOM	SIGNATURES DRAWN BY: JWB APPROV BY: JWB	DATE 1-1-2017 02/01/2017	Perlick Corporation Milwaukee, Wisconsin	
			TITLE: ASSEMBLY, SPEED RAIL	
QTY:			REFERENCE: 71009	
FINISH:			PART NO. 1006183-XX	DWG NO. 1006183
			PURCHASE REC.:	SCALE = 1:2 SHEET 2 OF 2

THIS DOCUMENT / PUBLICATION / SOFTWARE / DRAWING, CONTAINS PROPRIETARY INFORMATION WHICH IS THE PROPERTY OF THE PERLICK CORPORATION, IT MAY NOT BE REPRODUCED OR TRANSMITTED IN ANY FORM, ELECTRONIC OR MECHANICAL, INCLUDING PHOTOCOPYING, RECORDING, OR USED IN ANY INFORMATION STORAGE, TRANSMISSION, OR RETRIEVAL SYSTEM, WITHOUT WRITTEN PERMISSION FROM THE PERLICK CORPORATION. COPYRIGHT 2003 PERLICK CORPORATION. ALL RIGHTS RESERVED.