



# HOSHIZAKI

## Parts List

### Condensing Unit

Models  
SRC-10J



[hoshizakiamerica.com](http://hoshizakiamerica.com)

Number: 71408  
Issued: 4-18-2018  
Revised: 3-24-2022

## CONTENTS

Auxiliary Codes.....	3
Note About Ordering Parts .....	3
A. Main Assembly & Refrigeration Circuit .....	4
B. Control Box Assembly.....	6
C. Accessories & Labels .....	7

## **Auxiliary Codes**

### **SRC-10J**

G-0	September 2017
H-0	April 2018
J-0	January 2019
K-0	January 2020
L-0	January 2021
M-0	February 2022

## **Auxiliary Code Breakdown**

The auxiliary code is the first two characters in the serial number. The first character indicates the year. Years progress or regress in alphabetical order. The series runs from "A" through "V" and the letters "I" and "O" are skipped. The second character indicates significant part changes within a year. Base is "0" and this number advances for each change. In cases where there is a letter in parentheses, this designates the month. This is the last character in the serial number. The series runs from "(A)" through "(M)" and the letter "(I)" is skipped. This designation is only included when identifying a parts change within an auxiliary code.

## **Note About Ordering Parts**

Most assemblies cannot be ordered as complete units; parts in the assemblies generally must be ordered separately.

**A. Main Assembly & Refrigeration Circuit**  
**SRC-10J**  
G-0 to M-0

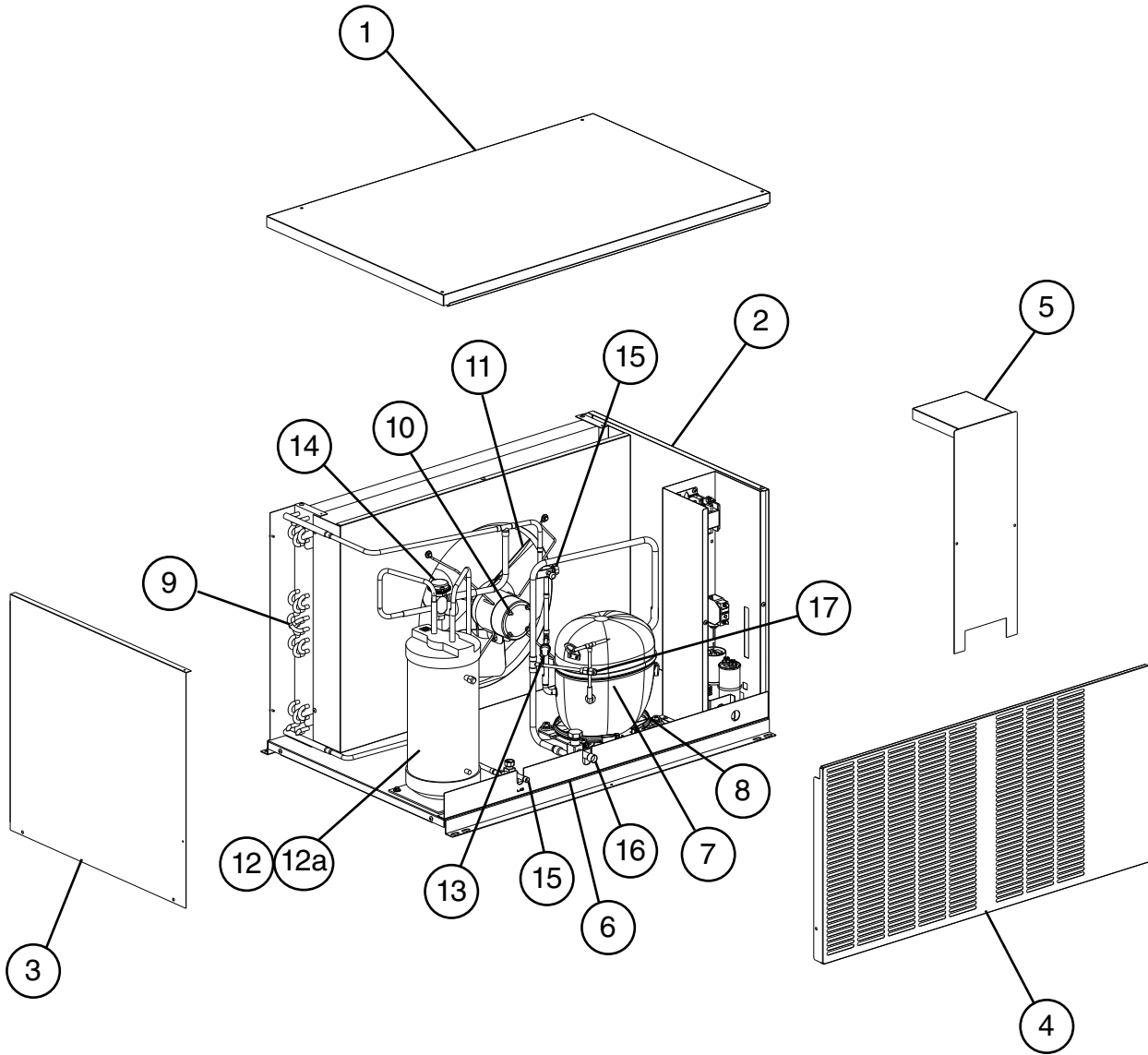

<b>Title: A. Main Assembly &amp; Refrigeration Circuit    Model: SRC-10J</b>											
Index No.	Description	Material or Model Number	Part Number	Required Number							
				G-0 to M-0							
<b>Main Assembly</b>											
1	Top Panel		3A9269-01	1							
2	Right Side Panel		3A9293-01	1							
3	Left side Panel		3A9292-01	1							
4	Louver Panel		3A9281-01	1							
5	Control Box Cover		3A9574-01	1							
6	Front Frame		3A9268-01	1							
<b>Refrigeration Circuit</b>											
7	Compressor		3A6900-02	1							
8	Crankcase Heater		4A5091-01	1							
9	Condenser		104777-02	1							
10	Fan Motor		4A6115-02	1							
11	Fan Blade		4A1493-01	1							
12	Receiver		4A6214-01	1							
12a	Hex Bolt		7B0230512	3							
13	High-Pressure Switch		463180-04	1							
14	Headmaster (C.P.R)		4A0229-06	1							
15	Liquid Line Shut Off Valve		4A3491-01	2							
16	Suction Line Shut Off Valve		4A3490-01	1							
17	Access Valve		457729-01	1							

**B. Control Box Assembly**  
**SRC-10J**  
 G-0 to M-0

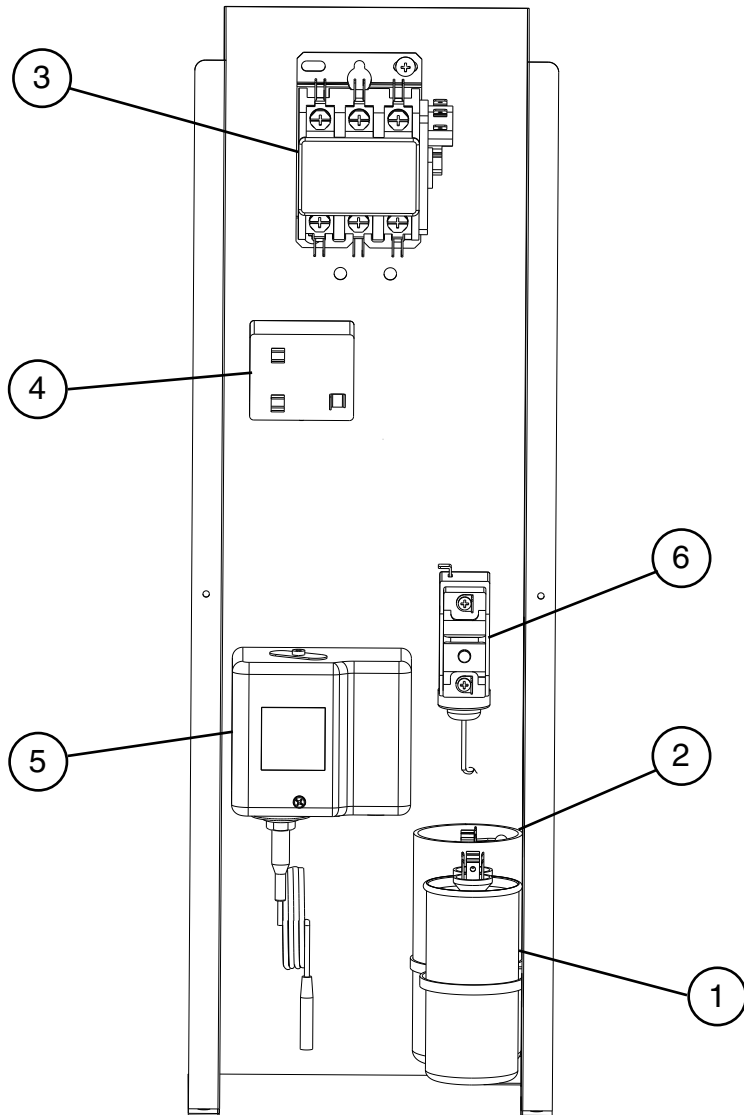

Title: B. Control Box Assembly Model: SRC-10J										
Index No.	Description	Material or Model Number	Part Number	Required Number						
				G-0 to M-0						
1	Run Capacitor	30MFD, 440VAC	3A2005-14	1						
2	Start Capacitor	108-130MFD, 330VAC	3A0076-22	1						
3	Magnetic Contactor		4A0794-01	1						
4	Start Relay		4A1107-07	1						
5	Control Low-Pressure Switch		4A6065-01	1						
6	Safety Low-Pressure Switch		4A3497-01	1						

## C. Accessories & Labels

### SRC-10J

G-0 to M-0

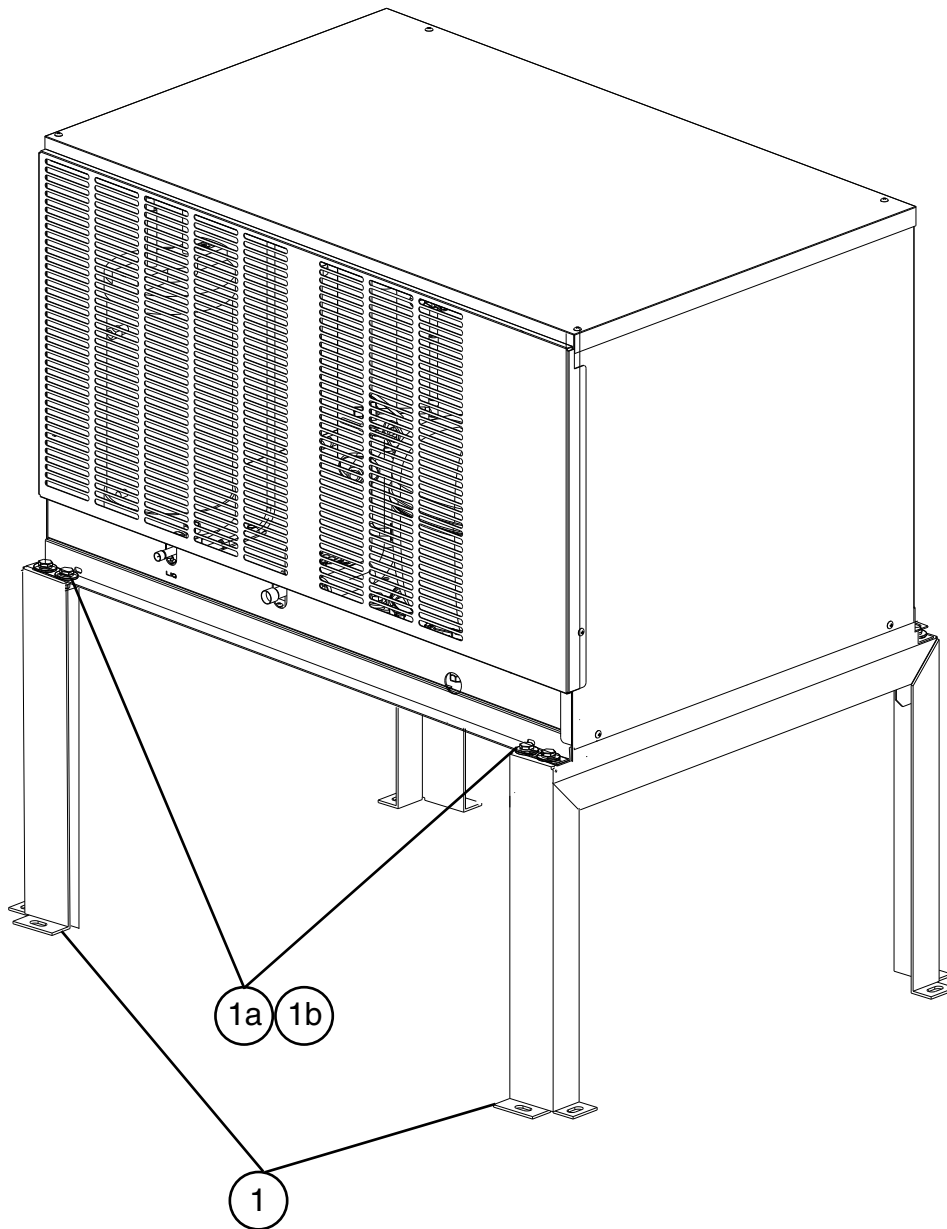

Title: C. Accessories & Labels		Model: SRC-10J		Required Number								
Index No.	Description	Material or Model Number	Part Number	G-0 to M-0								
1	Leg		2A8580G01	2								
1a	Hex Head Bolt w/ Washer	8x20, SS	7B0130820	8								
1b	Hex Nut	M8, SS	7N11-0800	8								